

GLOBAL

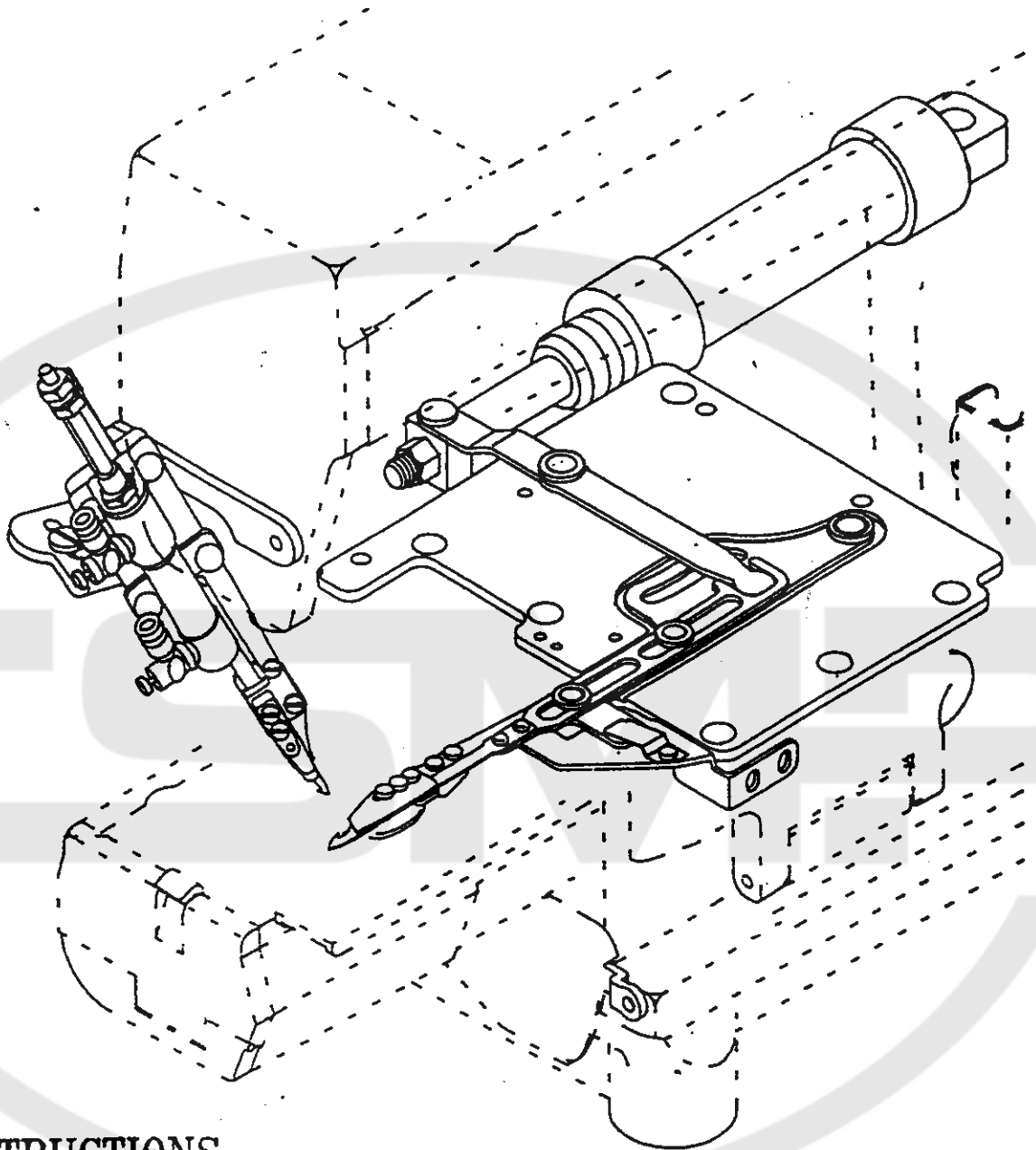

INSTRUCTIONS

MODEL

CB 2800 UTC Series -

1. APPLICATION :

1-1 THREADING AND TESTING

THE THREADING OF THIS SEWING MACHINE IS THE SAME AS CT SERIES, PLEASE REFER TO THE USER GUIDE OF CT SERIES INTERLOCK MACHINE.

- @ PLEASE BE AWARE THAT THE WRONG THREADING IS THE MAIN REASON TO CAUSE THE SKIP STITCH PROBLEM. IF THE UTA-1 DEVICE IS NOT ASSEMBLY ON THE MACHINE BY OUR FACTORY BUT PURCHASE SEPARATELY PLEASE ADJUST AND TEST THE MACHINE TO REACH THE BEST SEWING EFFECTS ACCORDING TO THE FABRICS AND THREAD YOU ARE USING FIRST AND THEN, ASSEMBLE THE UTA-1 DEVICE AFTERWARDS.
- @ DO NOT OPERATE THE UTA-1 DEVICE IF THERE IS NO FABRICS UNDER THE PRESSER FOOT.

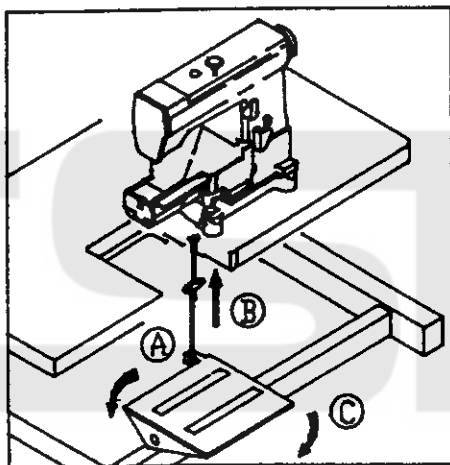

1. START THE SEWING MACHINE BY PUSHING THE PADEL FORWARD (A)
2. WHEN PEDAL BACK TO NEUTRAL POSITION (B) THE SEWING MACHINE STOP AND AT THIS MOMENT, YOU CAN SET THE NEEDLE TO ITS UPPER SET STOP POSITION OR LOWER SET STOP POSITION.
3. WHEN PUSHING THE PEDAL BACKWARD (C) THE NEEDLE REACH ITS UPPER SET STOP POSITION AND STOP THEN TRIMMING KNIFE START ITS OPERATION TO CUT THE LOOPER THREAD AND NEEDLE THREADS FIRST THEN CUT THE SPREADER THREAD NEXT AND PRESSER FOOT LIFT UP AUTOMATICALLY.
4. TAKE OFF THE SEWING FABRICS AND PREPARE FOR THE NEXT SEWING OPERATION.
5. BEFORE YOU PUSH THE PEDAL FORWARD, YOU CAN PUSH THE PEDAL BACKWARD AND LIFT UP THE PRESSER FOOT IN ORDER TO ADJUST THE FABRICS POSITION AT ANY TIME.

1-2 INSTALLMENT AND ADJUSTMENT OF THE SYNCHRONIZER :

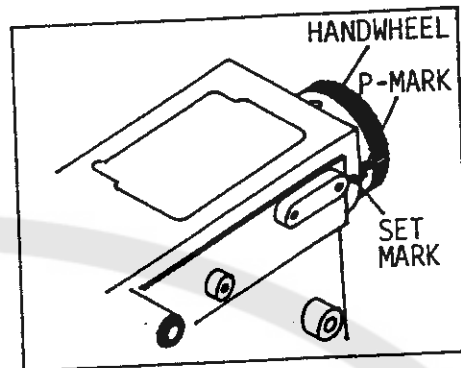
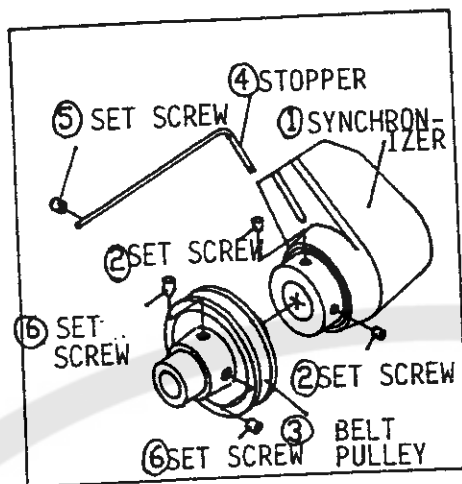

1. INSTALL SYNCHRONIZER ① INTO BELT PULLEY ③ AND TIGHTEN THE SET SCREW ② LIGHTLY.
2. INSERT ONE END OF STOPPER ④ INTO THE HOLE ON THE MACHINE AND INSERT THE OTHER END OF STOPPER INTO THE GROOVE OF SYNCHRONIZER AND THEN TIGHTEN THE SET SCREW ⑤
3. CONNECT THE POWER OF MOTOR (PLEASE DO NOT CONNECT THE ELECTRIC POWER OF TRIMMING KNIFE YET)
4. PUSH THE PEDAL AND START THE SEWING MACHINE AND THEN PUSH THE PEDAL BACKWARD TO STOP THE MACHINE. BY THIS TIME, THE SEWING MACHINE WILL STOP AT CERTAIN POSITION AUTOMATICALLY.
5. OBSERVE THE "P" SET MARK FROM HANDWHEEL AND WHEN THE MACHINE STOPPED. THE "P" SET MARK FROM HANDWHEEL SHOULD MATCH THE SET MARK ON THE SEWING MACHINE AND AT THIS MOMENT, THE NEEDLE SHOULD REACH ITS UPPERMOST DEAD POINT. WHILE ADJUSTING, LOOSEN THE SET SCREW ② TURNING THE BELT PULLEY ③ THEN TIGHTEN THE SET SCREW LIGHTLY, REPEAT SUCH PRECEDURE SEVERAL TIMES TO MAKE SURE THE "P" SET MARK FROM HANDWHEEL CAN MATCH EVEN WITH THE SET MARK OF THE MACHINE BODY.
6. AFTER TIGHTEN THE SET SCREW, PLEASE DOUBLE CHECK THE RELATED POSITION ONCE MORE TO MAKE SURE THESE TWO SET MARKS ARE MATCHING EVENLY.

1-3 ELECTRICITY AND CONNECTION OF ITS POWER CONTROL CYCLE.

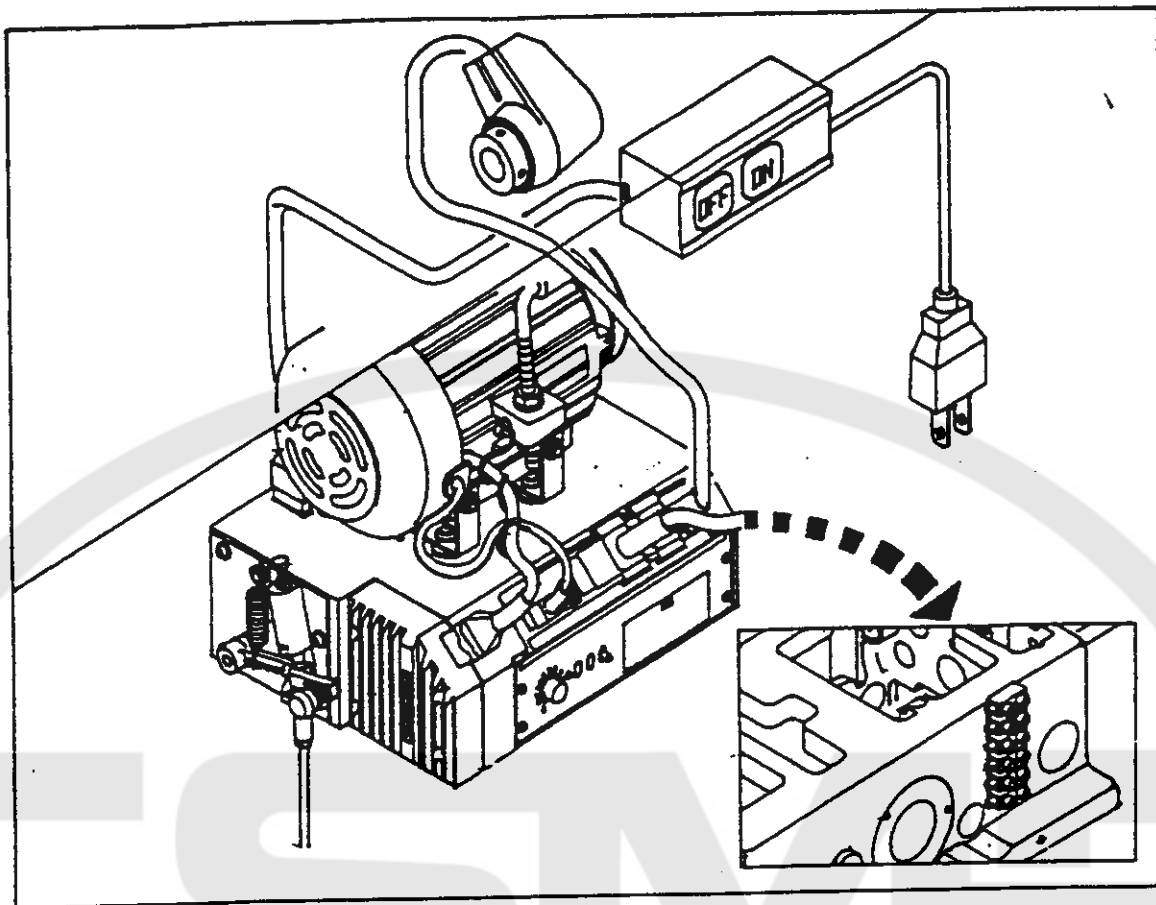

伺服馬達接線圖

GENERAL CONNECTION DIAGRAM OF AC SERVO MOTOR

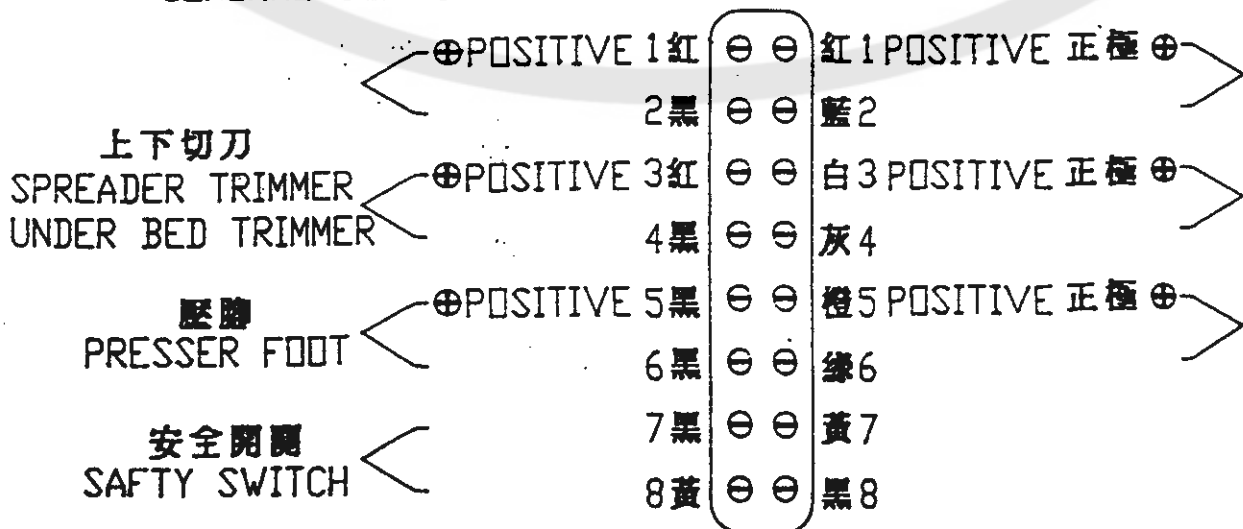

2. MAINTENANCE AND ADJUSTMENT

2-1 LOWER MOVABLE KNIFE AND FIXED KNIFE

IF YOU ARE RESHARPING THE KNIVES, OR CHANGING THE KNIVES, OR INCASE, TAKING OFF THE TRIMMING KNIFE SET IF NECESSARY AND YOU WANT TO RE-INSTALL THE TRIMMING KNIFE SET BACK, PLEASE REFER TO FOLLOWING ITEMS AND ADJUSTING THE RELATED PARTS INVOLVED.

@ PLEASE MAKE SURE THE POWER IS "OFF"

LOOSENING THE COMPRESSED AIR JOINT AND ADJUSTING THE POSITION OF LOWER MOVABLE KNIFE IN ORDER TO MAKE THE MOVABLE KNIFE CAN BE SLIDED EASILY IN THE LOWER MOVABLE KNIFE GUIDE AND CAN NOT INTERFERENCE WITH THE KNIFE GUIDE.

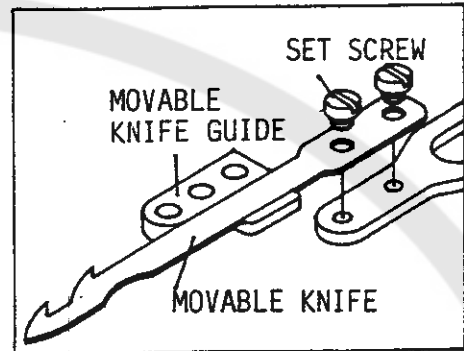

WHEN MOVABLE KNIFE MOVED TO ITS LEFTTEST DEAD POINT THERE SHOULD HAVE A INTERVAL OF 1m.m. BETWEEN SET SCREW A AND FIXED KNIFE AND CAN NOT COLLIDE WITH EACH OTHER. YOU CAN ADJUST THE INTERNAL BY LOOSEN THE SET SCREW B AND MAKE SURE THE EDGE OF MOVABLE KNIFE MATCH EVENLY WITH THE EDGE OF FIXED KNIFE.

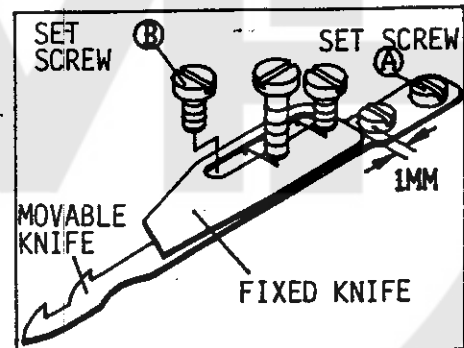

WHEN MOVABLE KNIFE MOVED TO ITS RIGHTEST DEAD POINT, THE HOOK BALDE OF MOVABLE KNIFE SHOULD BE RETREAT 1m.m. INSIDE FROM THE BLADE OF FIXED KNIFE.

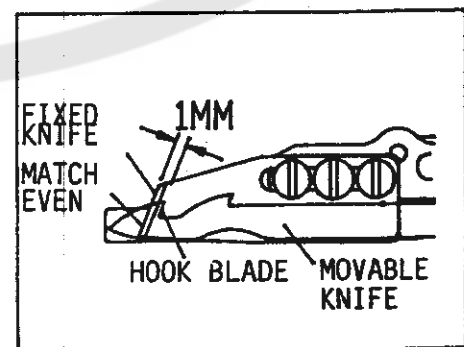

THE RELATIONSHIP AMONG CLAMP SPRING, KNIFE PRESSURE SPRING AND CLAMP SPRING PRESSURE ADJUSTING PIECE.

WHEN THE HOOK BLADE OF MOVABLE KNIFE A RETREATED 1mm INSIDE FROM THE BALDE OF FIXED KNIFE B, THE FRONT EDGE OF CLAMP SPRING C SHOULD MATCH EVEN WITH THE TOP OF MOVABLE KNIFE. SIDE EDGE OF MOVABLE KNIFE AND CLAMP SPRING ALSO SHOULD MATCH EVENLY.

WHEN LOOPER THREAD BEEN CUT, THE CLAMP SPRING SHOULD HOLD THE LOOPER THREAD AND MOVING AWAY TOGETHER WITH KNIFE BASE FROM THE LOOPER AND THE PRESSURE OF CLAMP SPRING CAN BE ADJUSTED BY ADJUSTING THE CLAMP SPRING PRESSURE ADJUSTING PIECE AND PLEASE REFER TO NEXT ITEM.

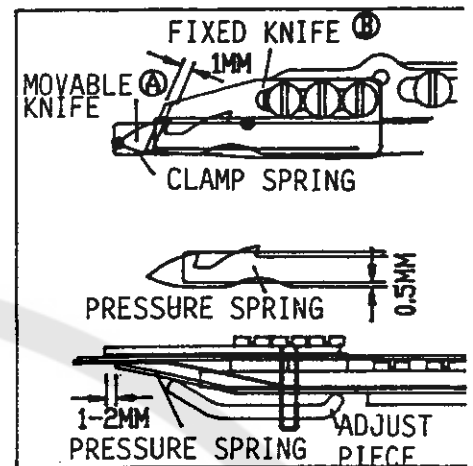

2-2 SETTING THE HEIGHT OF THE LOWER FIXED KNIFE CARRIER GUIDE

WHEN LOWER MOVABLE KNIFE MOVE FORWARD FROM LOWER KNIFE HOLDER, THE INTERNAL BETWEEN MOVABLE KNIFE AND THE RIDGE OF LOOPER SHOULD BE 0.1 ~ 0.3 m.m.

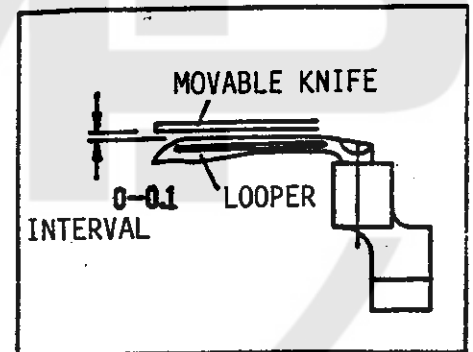

LOOSENING THE SET SCREW A AND ADJUSTING THE HEIGHT OF LOWER FIXED KNIFE CARRIER GUIDE TO ITS PROPER POSITION THEN TIGHTEN THE SET SCREW A. PLEASE MAKE SURE THE LOWER MOVABLE KNIFE CAN BE MOVED FORWARD AND BACKWARD SMOOTHLY.

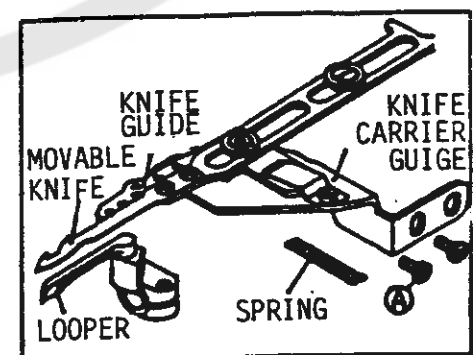

2-3 SETTING THE POSITION OF THREAD TRIMMER

WHEN THE PISTON OF KNIFE DRIVING CYLINDER REACH ITS LEFTTEST DEAD POINT AND TRIMMING KNIFE SET WILL MOVE TO THE SIDE OF THE LOOPER. THERE WILL BE A 2m.m. INTERVAL BETWEEN THE TRIMMING KNIFE SET AND THE LOOPER.

LOOSEN THE SET SCREW NUT (A), TURNING THE PISTON CLOCKWISE TO REDUCE THE INTERVAL OR COUNTER CLOCKWISE TO INCREASE THE INTERVAL, TO ADJUST THE TRIMMING KNIFE SET TO ITS PROPER POSITION AND THEN TIGHTEN THE SET SCREW NUT

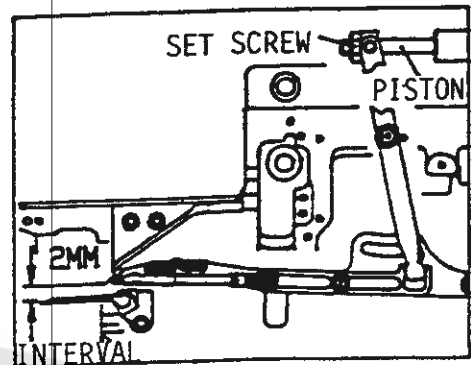

TURNING THE HANDWHEEL AND MAKE SURE THE "P" SET MARK MATCH THE SET MARK FROM THE MACHINE HEAD. USING HAND TO MOVE THE PISTON OF THE KNIFE DRIVING CYLINDER IN ORDER TO MOVE THE TRIMMING KNIFE SET TO THE LOOPER

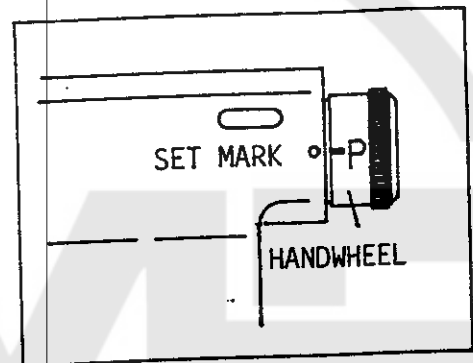

KEEP PUSHING THE PISTON OF KNIFE DRIVING CYLINDER, THEN THE MOVABLE KNIFE START TO MOVE FORWARD.

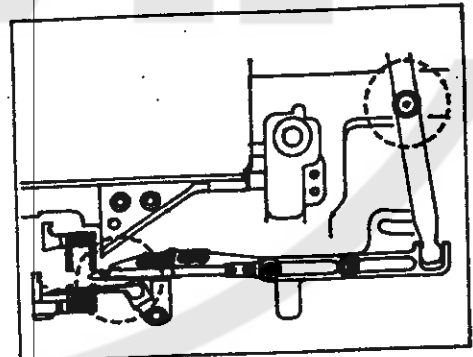

WHEN THE MOVABLE KNIFE MOVE TO 1.5m.m. FROM THE LEFT EDGE OF FEED DOG'S RIGHT COLUMN. THE TIP OF THE MOVABLE KNIFE SHOULD LOCATED ON THE TOP OF THE CENTER LINE OF LOOPER'S RIDGE.

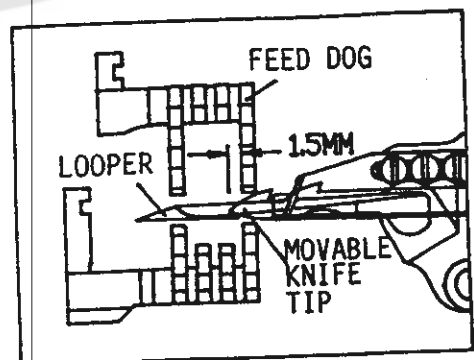

WHEN MOVABLE KNIFE KEEP MOVING TO THE LEFT TILL 1.5mm AWAY FROM THE RIGHT SIDE OF FEED DOG'S LEFT COLUMN, THE TIP OF THE MOVABLE KNIFE SHOULD STILL STAY WITHIN THE RIDGE OF THE LOOPER.

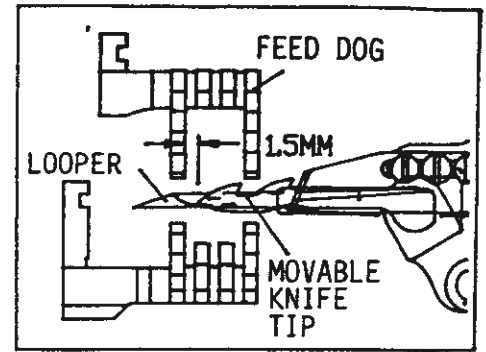

WHEN ADJUSTING, LOOSENING THE SET SCREW (A) AND TURNING THE ECCENTRIC STUD AND SETTING THE POSITION OF THE TIP OF MOVABLE KNIFE (THE SET MARK OF THE ECCENTRIC STUD MUST FACING TOWARD THE RIGHT SIDE).

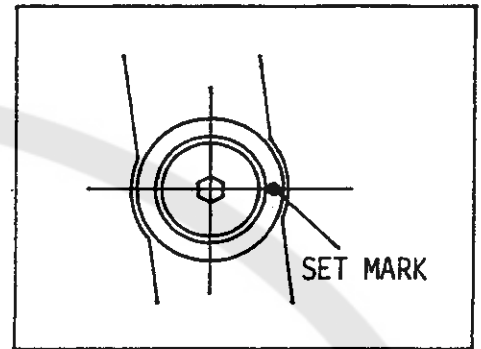

2-4 DOUBLE-CHECKING

AFTER ASSEMBLED THE THREAD TRIMMING SET, PRIOR TO THE SEWING OPERATION, YOU MUST DOUBLE CHECK THE CORRELATION OF NEEDLE THREAD, LOOPER THREAD, LOWER MOVABLE KNIFE AND LOOPER, AND ALSO DOUBLE CHECK IF THE THREAD TRIMMER CAN TRIM THE THREADS PROPERLY AND IF CLAMP SPRING CAN HOLD THE LOOPER THREAD PROPERLY.

WHEN MOVABLE KNIFE (A) MOVE FROM RIGHT TO THE LEFT, IT MUST PASSING THROUGH THE LOOP OF THE NEEDLE THREADS (U) (U'). IN THE SAME TIME, THE POSITION OF HOOK BLADE (a) MUST BE IN THE FRONT OF LOOPER THREAD.

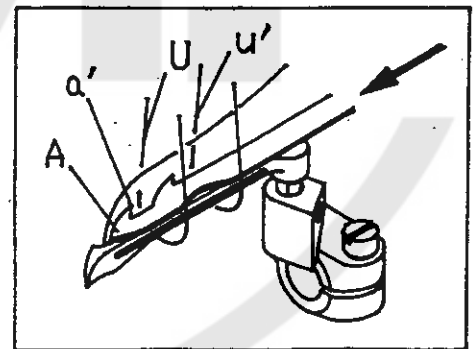

WHEN MOVABLE KNIFE (A) RETREAT FROM ITS LEFTTEST DEAD POINT TO THE RIGHT, HOOK BLADE (a) AND (a') WILL PULL THE NEEDLE THREAD AND LOOPER THREAD TO THE FIXED KNIFE AND CUT THE THREADS IN ORDER AND THE CLAMP SPRING WILL HOLD THE THREAD END AND MOVE TO THE BACK OF LOOPER TOGETHER WITH TRIMMING KNIFE SET (A). YOU CAN ADJUST THE HOLDING PRESSURE OF CLAMP SPRING TO AVOID THE THREAD END CAME OFF DURING THE MOVEMENT BY ADJUST CLAMP SPRING PRESSURE ADJUSTING PIECE.

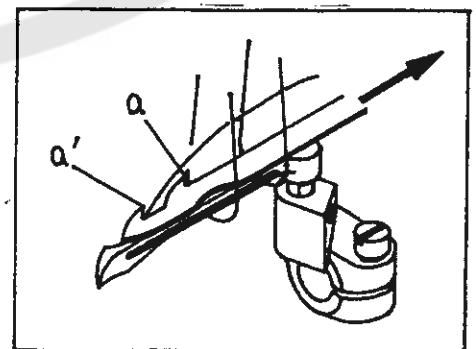

THE TRIMMING ABILITY OF KNIFE MUST BE MODERATE OR THE KNIFE WILL BE WORE OUT VERY SOON. IF THE TENSION OF KNIFE PRESSURE SPRING IS TOO BIG. YOU CAN ADJUST IT BY MOVING KNIFE PRESSURE SPRING TO THE RIGHT OR LEFT IN ORDER TO GET PROPER TENSION.

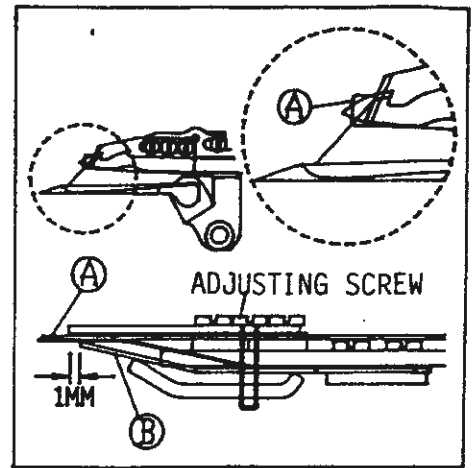

DOUBLE CHECK THE POSITION OF SAFETY SWITCH WHEN THE POWER IS ON, THE TRIMMING KNIFE SET MUST BE IN ITS SET POSITION.

THE TRIMMING KNIFE SET CAN ONLY FUNCTION WHEN THE KNIFE DRIVING CYLINDER (B) PUSH AWAY SAFETY SWITCH (A). WHEN ADJUSTING, LOOSENING SET SCREW (C) AND SETTING THE DESIRED POSITION FOR SAFETY SWITCH THEN TIGHTEN SET SCREW (C). AFTER TIGHTEN THE SET SCREW (C) YOU MUST DOUBLE CHECK IF SAFETY SWITCH IS SET PROPERLY.

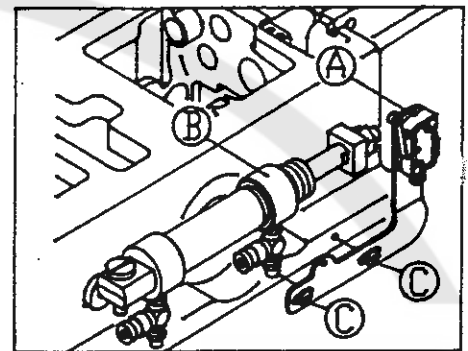

3. TENSION RELEASE EQUIPMENT

EACH OF SET SCREWS FOR THE TOP THREE THREAD GUIDE HOOK UNITS IS SETTING IN THE MIDDLE OF TWO THREAD GUIDE EYELETS AND EACH OF SET SCREWS FOR THE BOTTOM TWO THREAD GUIDE HOOK UNITS IS SETTING IN THE DISTANCE OF 10m.m. APART FROM THE THREAD GUIDE EYELET.

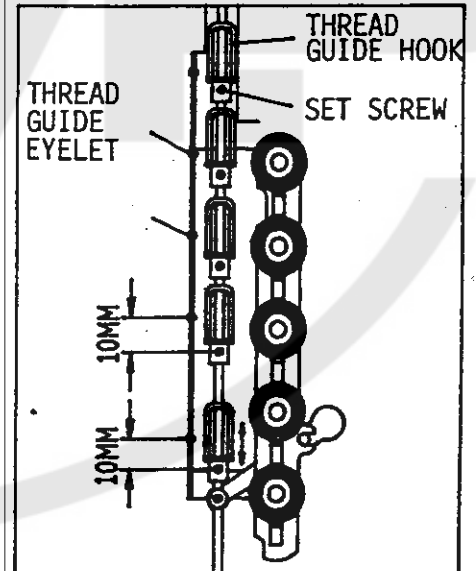

THE RELEASE WEDGE MUST REACT EARLIER THAN THE THREAD TRIMMER'S OPERATION, WHEN ADJUSTING, LOOSENING THE SET SCREW, SETTING THE PROPER POSITION OF RELEASE WEDGE. IN THE MEANTIME, PLEASE MAKE SURE THE RELEASE WEDGE CAN PUSH TENSION DISC COMPLETE APART AND ALSO CAN RETREAT COMPLETELY (CAN NOT INTERFERENCE WITH TENSION DISC.)

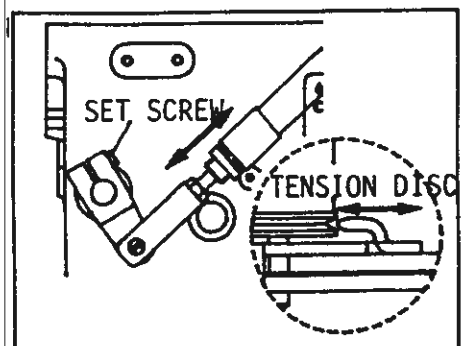

4. ADJUSTMENT FOR SPREADER TRIMMER

4-1 THE EXPLANATION FOR TRIMMING OPERATION.

WHEN NEEDLE MOVED TO ITS UPPERMOST DEAD POINT, MOVABLE KNIFE (A) PASSING THROUGH THE NEEDLES AND THE LOOP OF SPREADER THREAD (CAN NOT INTERFERENCE WITH EACH OTHER.). WHEN THE TIP OF MOVABLE KNIFE MOVED TO THE HALF DISTANCE BETWEEN SPREADER AND PRESSER FOOT AND START RETREATING BY THIS MOMENT THE HOOK BLADE OF MOVABLE KNIFE IS PULLING THE ORNAMENTAL THREAD BACK TILL THE FIXED KNIFE CUT THE ORNAMENTAL THREAD AND THE THREAD CLAMP SPRING IS HOLDING THE ORNAMENTAL THREAD END.

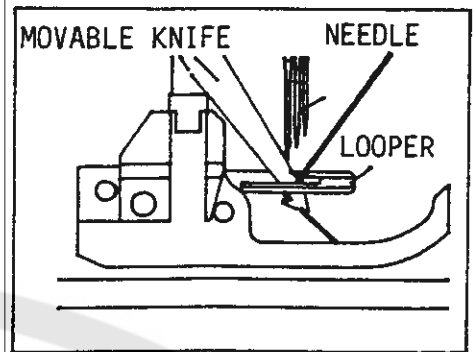

4-2 MAINTENANCE AND ADJUSTMENT

WHEN MOVABLE KNIFE PASSING THOUGH THE NEEDLES AND SPREADER, THE INTERVAL BETWEEN MOVABLE KNIFE AND SPREADER SHOULD BE 0.1~0.3 m.m. LOOSEN THE SET SCREW AND ADJUST THE SPREADER TRIMMER SET TO ITS PROPER POSITION AND THEN TIGHTEN THE SET SCREW.

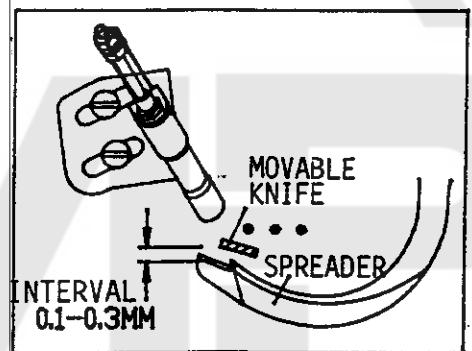

WHEN MOVEABLE KNIFE MOVE FORWARD AND MEET WITH SPREADER, THE TIP OF HOOK BLADE SHOULD SQUARE MATCH TO THE THREAD HOOK OF SPREADER. LOOSEN THE SET SCREW, ADJUST THE HOOK BLADE OF MOVABLE KNIFE TO ITS PROPER POSITION AND LINE UP WITH THREAD HOOK OF SPREADER THEN TIGHTEN THE SET SCREW.

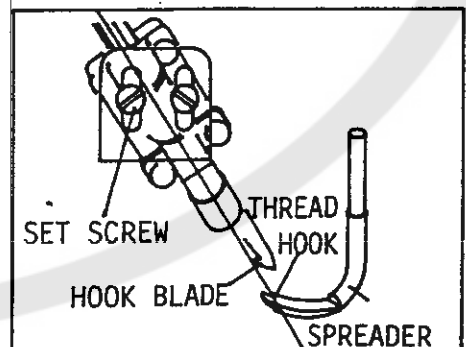

WHEN MOVABLE KNIFE MOVE FORWARD TO ITS LOWEST DEAD POINT, THE TIP OF THE MOVABLE KNIFE SHOULD LOCATE AT THE HALF DISTANCE BETWEEN SPREADER AND PRESSER FOOT. LOOSEN THE NUT OF CYLINDER, ADJUST THE PISTON TO ITS PROPER POSITION THEN TIGHTEN THE NUT.

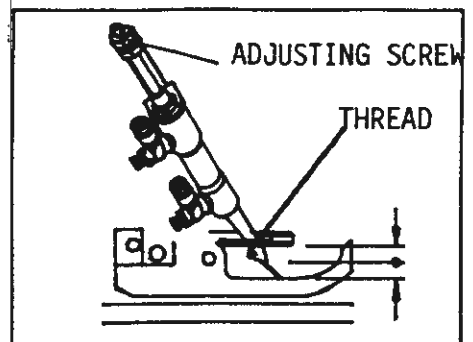

WHEN RE-SHARPENING THE KNIVES, OR CHANGING THE KNIVES OR TAKING OFF THE SPREADER TRIMMER SET IF NECESSARY, PLEASE ASSEMBLE BACK THE SPREADER TRIMMER ACCORDING TO FOLLOWING ITEMS.

MOVABLE KNIFE SHOULD SLIDE SMOOTHLY IN THE SLIDE BLOCK AND CAN NOT HAVE ANY INTERVAL BETWEEN MOVABLE KNIFE AND SLIDE BLOCK.

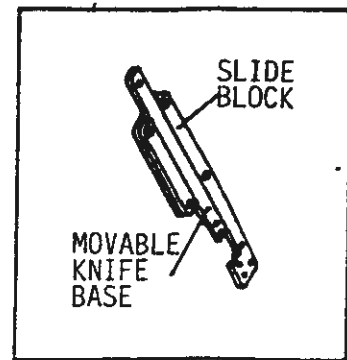

THE SIDE EDGE OF FIXED KNIFE SHOULD MATCH EVENLY WITH FIXED KNIFE HOLDER.

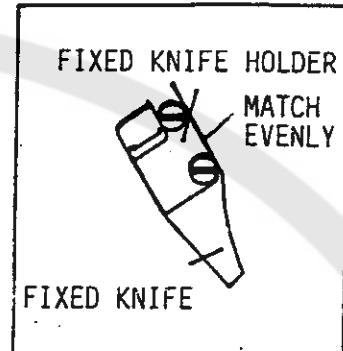

WHEN MOVABLE KNIFE MOVE BACKWARD, THE HOOK BLADE OF MOVABLE KNIFE SHOULD RETREAT 0.5m.m. INSIDE FROM THE BLADE OF FIXED KNIFE.

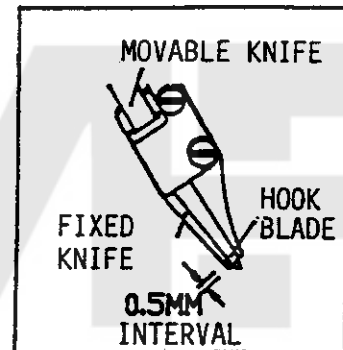

WHEN MOVABLE KNIFE MOVE TO ITS UPPERMOST DEAD POINT, THE FRONT EDGE OF THREAD CLAMP SPRING AND MOVABLE KNIFE SHOULD BE EVEN. AND THE FRONT EDGE OF KNIFE PRESSURE SPRING AND FIXED KNIFE SHOULD BE EVEN.

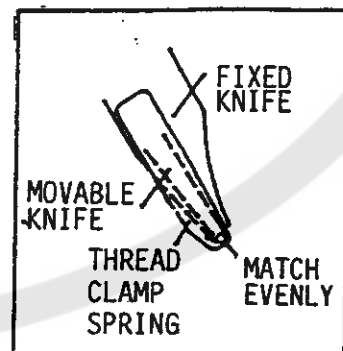

ADJUSTING SCREW IS USED FOR SETTING THE TENSION OF CLAMP SPRING IN ORDER TO HOLD THE ORNAMENTAL THREAD PROPERLY. IF THE TENSION BETWEEN THREAD CLAMP SPRING AND MOVABLE KNIFE IS TOO BIG, THEN MOVE THE KNIFE PRESSURE SPRING FORWARD IN ORDER TO GET PROPER TENSION.

