

Yamato®

Instruction Manual (with Parts List)

HIGH SPEED OVERLOCK MACHINE
with Floating Presser Foot

HIGH SPEED SAFETY STITCH MACHINE
with Floating Presser Foot

AZ8060G
AZ8560G

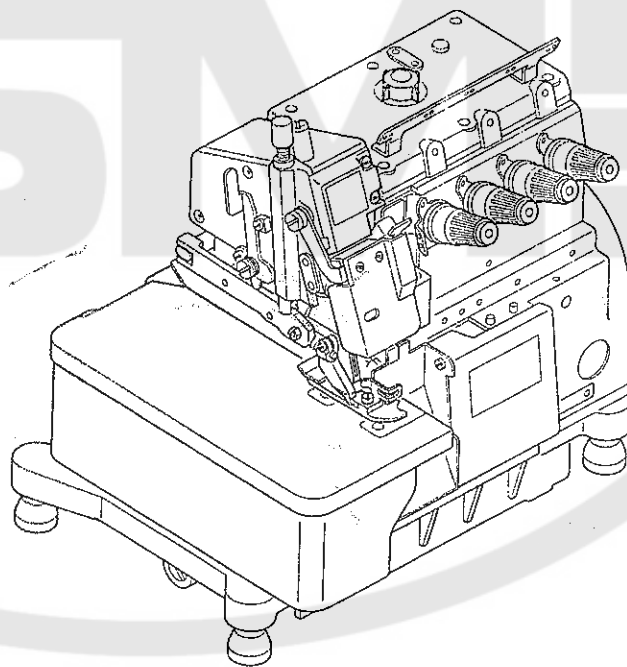

Thank you for purchasing the Model AZ8060G/AZ8560G. This instruction manual provides information on the floating presser foot.

Before using your AZ8060G/AZ8560G, please read the instruction manual together with that for the AZ8000G/AZ8500G and well understand the contents of both documents.

After reading the instruction manual, please store it in a location where it is easily accessible to the operator.



YAMATO SEWING MACHINE MFG.CO.,LTD.

1. Introduction to Model with Floating Presser Foot

1. Features

- The presser foot slides back and forth in conjunction with the vertical and reciprocative movement of the lower feed dog. This mechanism minimizes the twist and deviation of the fabric to be sewn, providing the fabric with a flat, beautiful finish.
- The pressing pressure applied to the fabric to be sewn is decreased, minimizing the bad effect over the fabric.

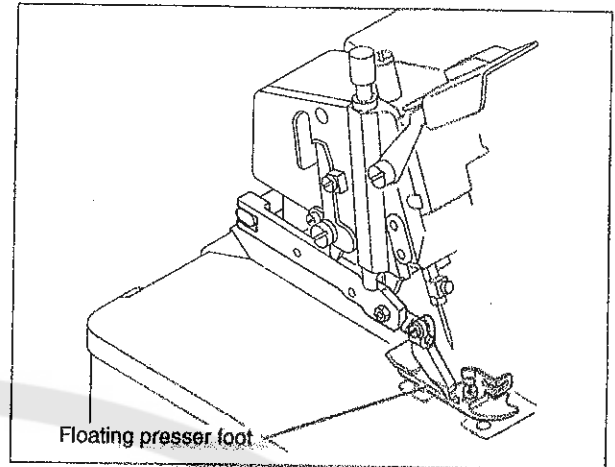

Movement of floating presser foot

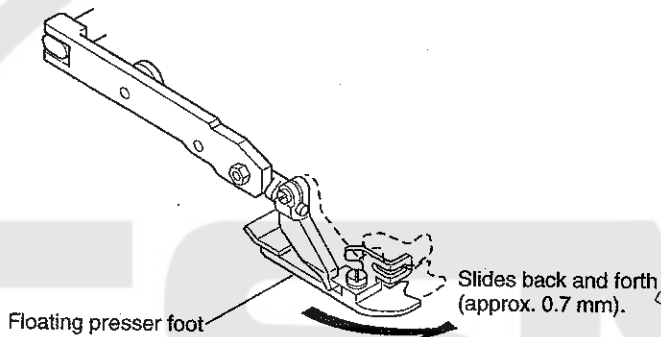

Movement of standard presser foot

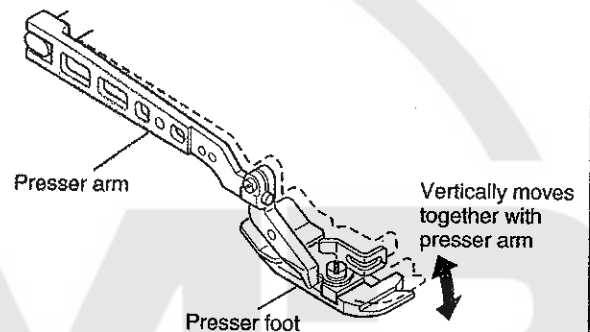

2. Differences from AZ8000G/AZ8500G

⚠ CAUTION

The maximum sewing speed and presser foot lift are different between the model with floating presser foot (AZ8060G/AZ8560G) and the Model AZ8000G/AZ8500G (see the table given on the right side).

Model	AZ8060G class	AZ8560G class
Max. sewing speed	7000 r.p.m	6500 r.p.m
Presser foot rise	5 mm max.	5 mm max.

3. Motor Pulley

In order to achieve the maximum performance of the model with floating presser foot, the maximum sewing speed must be lower than that of the AZ8000G/AZ8500G. This will require changing the motor pulley used. Select the best suited motor pulley from the table provided on right side.

⚠ CAUTION

Use a motor pulley applicable for the AZ8060G/AZ8560G. Otherwise, the maximum speed will be exceeded and your sewing machine may malfunction.

List of motor pulleys

Outer dia. of motor pulley (mm)	Sewing machine speed (r.p.m.)	
	For 50 Hz	For 60 Hz
90		6000
95		6400
100		6700
110	6200	
115	6500	
120	6700	

* The sewing machine speeds shown in the above table are the values that are obtained when a clutch motor for power supply of 3 phases, 2 polarities, and 400 W is used.

* The outer diameters of commercially available pulleys are in units of 5 mm. Therefore, the above table lists the motor pulleys that have the outer diameters closest to those of the commercially available ones.

2. Assembling the Floating Presser Foot

To replace the the presser arm and presser foot, C. set for the AZ8000G/AZ8500G with the floating presser foot, perform the following steps:

1. Components for floating presser foot

Check the parts with the table given on the right side before assembling the floating presser foot.

Part name	Q'ty
Floating presser arm, C. set	1
Presser foot, C. set	1
Presser foot release lever stop	1
Screw	1

2. Assembling the floating presser foot

CAUTION

Before starting these steps, be sure to turn OFF the power and then check that the motor rotation stops.

1. Remove the belt from the pulley.
2. Manually rotate the pulley for the sewing machine to position the feed dog lower than the upper surface of the stitch plate.
3. Remove the stopper screw for the presser foot release lever.
4. Tighten the screw for the lever stop as illustrated right.
5. Release the lever and open the presser arm.

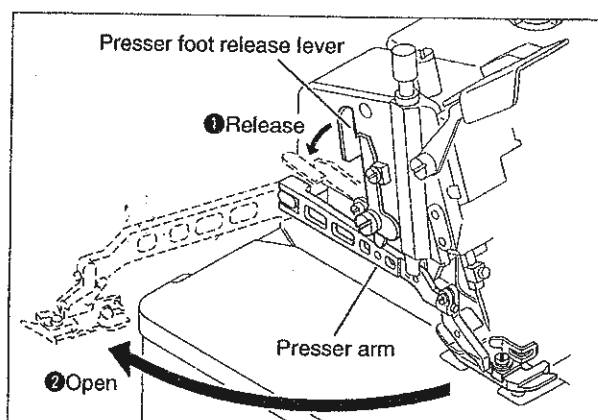
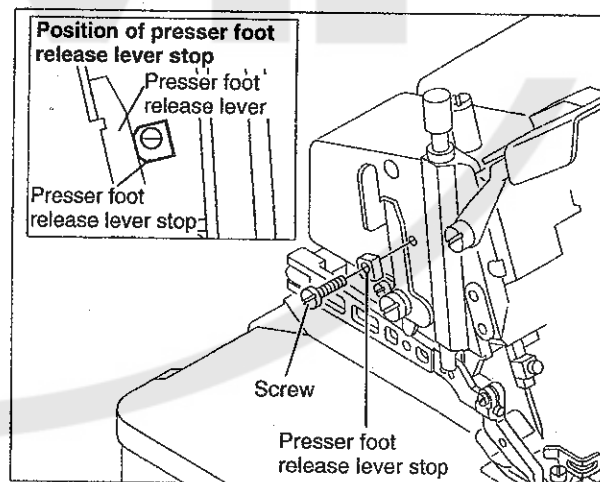
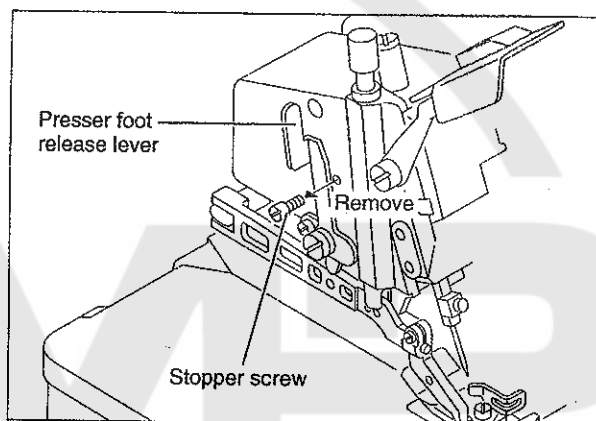

2. Assembling the Floating Presser Foot

- 6.** Remove the presser arm and the presser foot, C. set from the presser foot shaft.

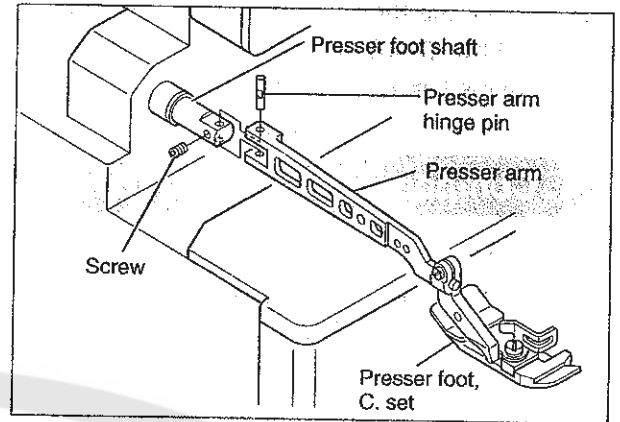

- 7.** Connect the floating presser arm, C. set to the presser foot shaft.

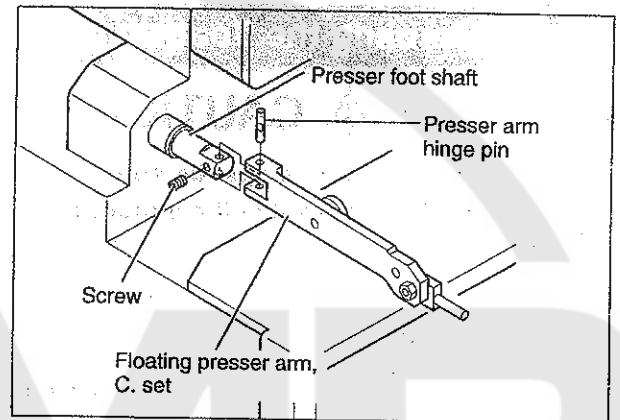

- 8.** Adjust the clearance between the top of the lock nut and that of the adjusting screw at 24 mm. (See Page 6 for adjusting this clearance.)

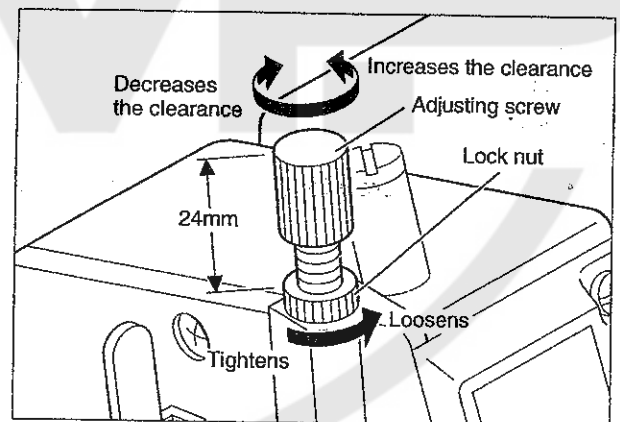

- 9.** Insert the presser foot, C. set to the floating presser arm, C. set.

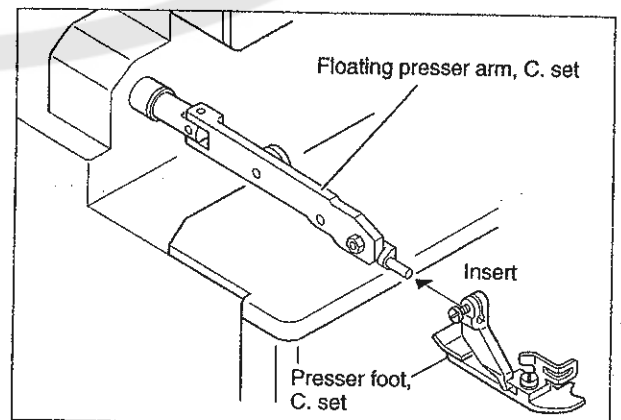

10. Install the floating presser arm back in place.
11. Align the needle drop of the presser foot, C. set with that of the stitch plate, and then tighten the lock screw for the presser foot, C. set.

CAUTION

In aligning the needle drop of the presser foot, C. set with that of the stitch plate, adjust the bottom of the presser foot to be in parallel with the stitch plate.

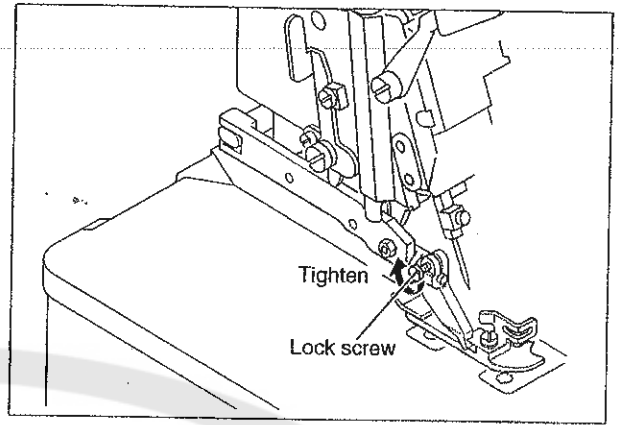

3. Adjustment after Installation

1. Check that the feed dog is positioned lower than the upper surface of the stitch plate.
2. Check that the lever makes contact with the presser foot pin.
3. Check that the needle drop of the presser foot, C. set aligns with that of the stitch plate. (front/rear, right/left and parallel position)
4. Check that the clearance between the top of the groove on the presser arm stop and that of the floating presser arm, C. set stop is between 0.5 and 1 mm. To adjust the clearance, change the position of the lever stop.

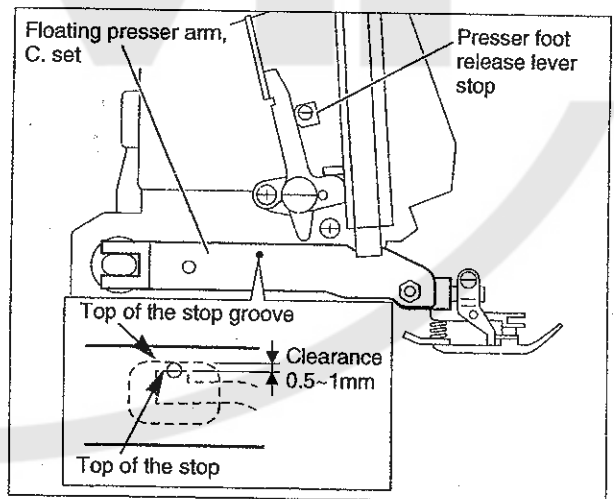
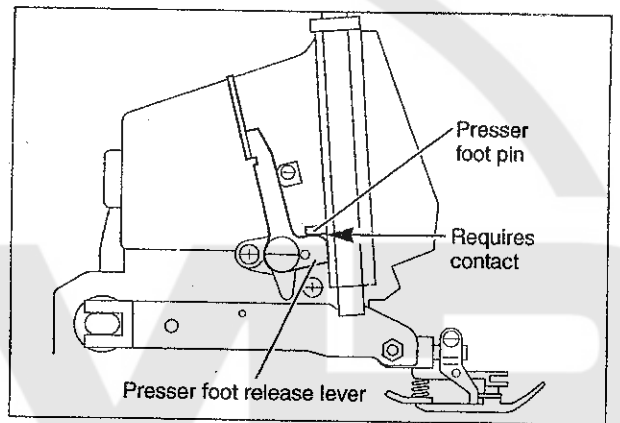

Lever stopper positions and clearance changes
(the clearance increases in the order of left to right)

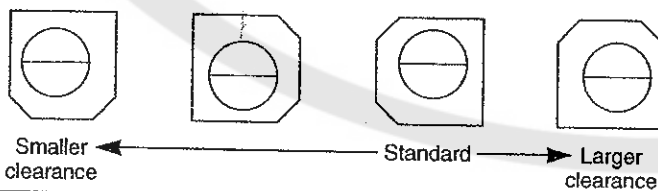

5. Loosen the lock nut for the stopper screw on the presser foot shaft lever, and the screw for the presser arm stop.

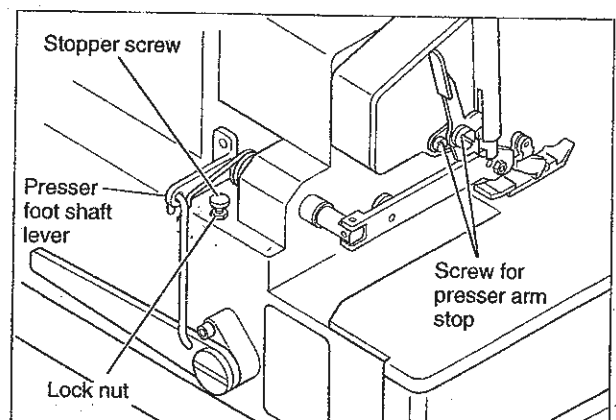

2. Assembling the Floating Presser Foot

- 6.** Depress the presser release lever, and then insert something of 5 mm in thickness between the top of the stitch plate and the bottom of the presser foot, such that they are in parallel with one another.

① When the release lever is depressed, the floating presser arm, C. set will be positioned as illustrated.

② When something of 5 mm in thickness is inserted between the top of the stitch plate and the bottom of the presser foot, the floating presser arm, C. set will be positioned as illustrated.

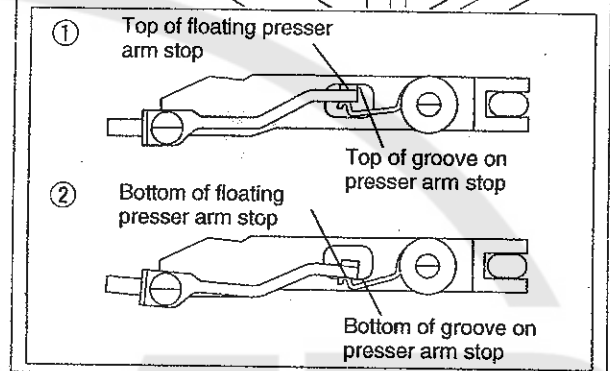
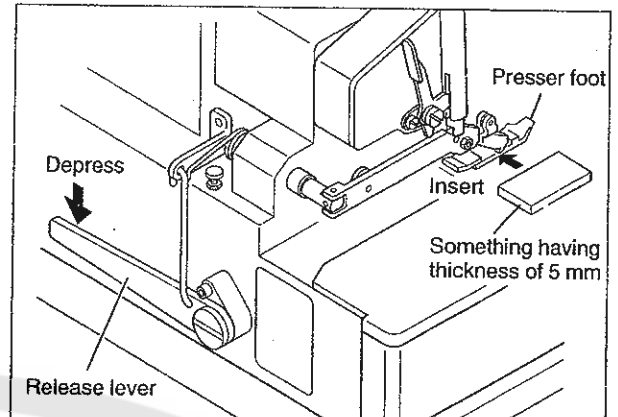

- 7.** Let the stopper screw make contact with the shaft lever when the presser arm and floating presser arm are positioned as illustrated in ②, and then tighten the lock nut.

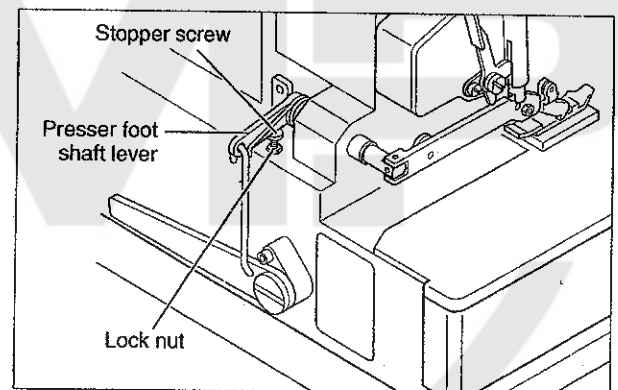

- 8.** Let the presser arm stop make contact with the presser arm, and then tighten the screw.

- 9.** Remove the thing that has been inserted between the top of the stitch plate and the bottom of the presser foot.

- 10.** Manually rotate the pulley for the sewing machine, and check that the presser rod does not move vertically. If the presser rod moves, tighten the adjusting screw until the presser rod no longer moves vertically. (For the adjusting procedure, see P. 6.)

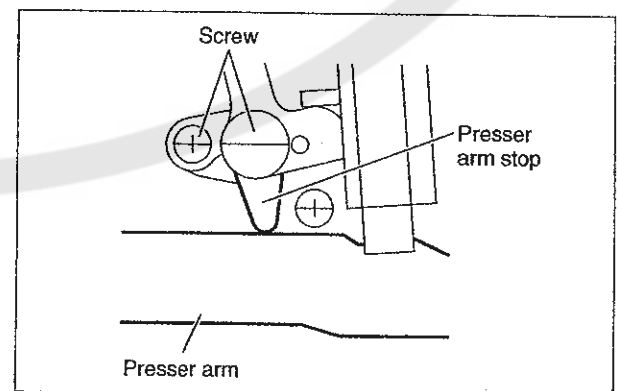

- 11.** Stretch the belt between the sewing machine and motor pulley.

- 12.** Activate the sewing machine and check that the presser foot functions properly. If the presser foot does not function properly, adjust the presser foot adjusting spring. (For the adjusting procedure, see P. 6.)

- 13.** Check that the presser arm remains stationary when the leading edge of the presser foot is lifted with a finger.

3. Troubleshooting

1. Troubleshooting

CAUTION

Before starting these steps, be sure to turn OFF the motor and then check that the motor rotation stops.

Trouble	Corrective action
● Idling noises are too loud.	→ Adjust the position of the adjusting screw for the presser foot by 90°. (See "3. Adjustment the presser foot adjusting spring")
● The fabric is not fed straight.	→ Perform the steps 10 to 13 under "Adjustment after Installation."
● The fabric is not fed properly.	→ Perform the steps 10 to 13 under "Adjustment after Installation."
● The fabric deviates greatly.	→ Perform the steps 10 to 13 under "Adjustment after Installation."
● The fabric is often flawed during feed.	→ Perform the steps 10 to 13 under "Adjustment after Installation."

2. Adjusting the presser foot spring

Loosen the lock nut and then adjust the presser foot spring by turning the adjusting screw. To check the adjusted state or measure any dimension, tighten the lock nut in advance.

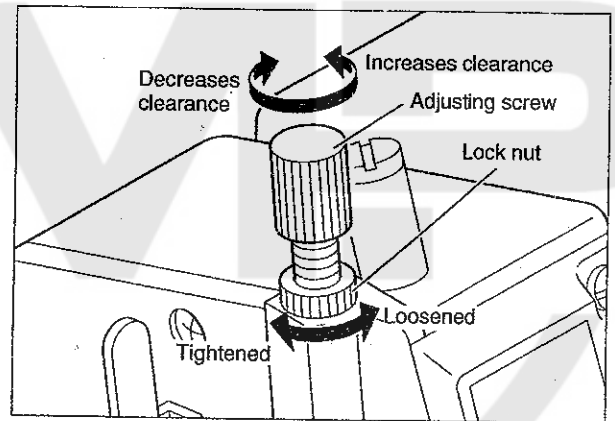

3. Adjusting the presser foot adjusting spring

Adjust the position of the presser foot spring in a range between 60° and 90°. (The presser foot spring was adjusted in the position of 60° at factory.)

1. Depress the presser foot release lever and open the presser arm.
2. Loosen the lock screw for the presser foot adjusting spring using a slotted screwdriver, adjust the position of the adjusting spring, and then tighten the lock screw.
3. After finishing the adjustment, install the presser arm back in place and check that it remains stationary when the leading edge of the presser foot is lifted with a finger.

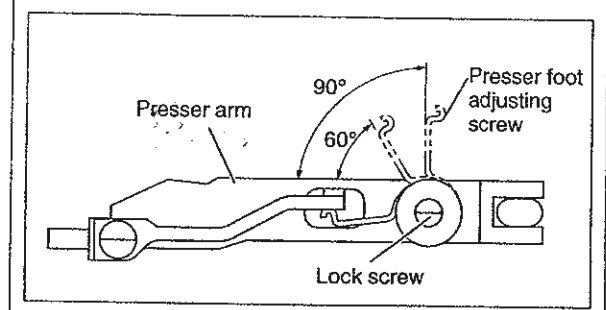
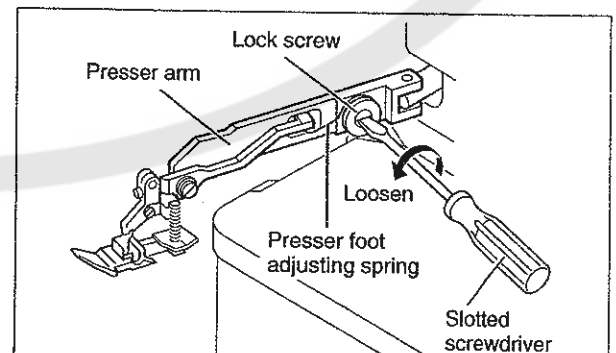

4. Parts List

AZ8062G/AZ8069G

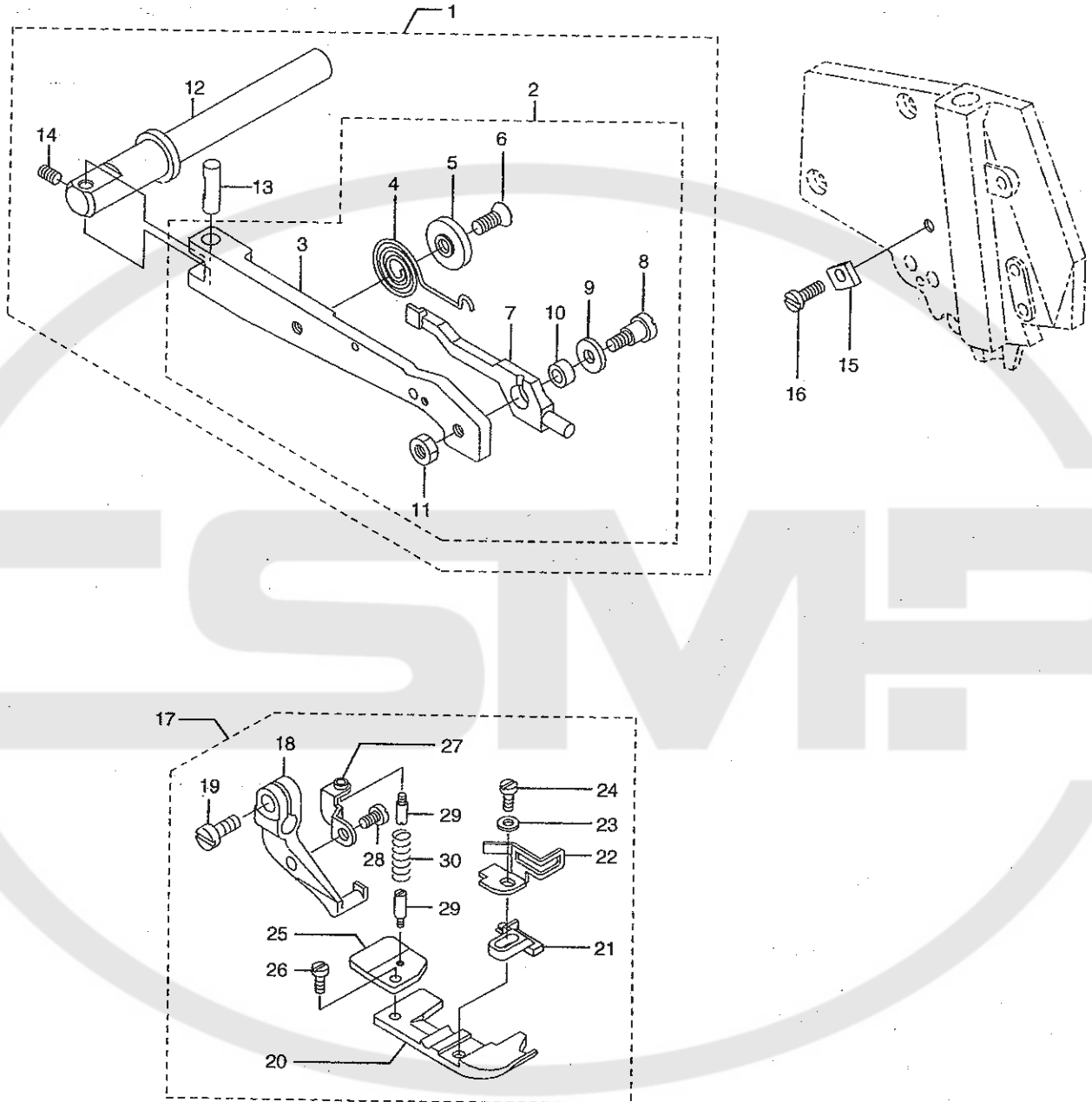

AZ8062G · AZ8069G EXCLUSIVE PARTS サブモデル専用部品

Ref.No.	Parts NO.	Description	品名	Amt. Req.
1	2150220	Presser Arm, C. Set	押工腕 (組)	1
2	2150223	Floating Presser Arm, C. Set	フローティングアーム (組)	1
3	2150221	Presser Arm	押工腕	1
4	2100750	Adjusting Spring	調節バネ	1
5	2100751	Locking Disc	回り止め	1
6	130010	Screw (M4 -0.7×8.3)	止ネジ	1
7	2150222	Floating Presser Arm	フローティングアーム	1
8	170039	Screw (M4 -0.7×12)	止ネジ	1
9	300000	Washer	ワッシャ	1
10	2100752	Bushing	ブッシュ	1
11	100001	Nut	ナット	1
12	2100189	Presser Foot Shaft	押工軸	1
13	2100199	Presser Arm Hinge Pin	押工腕ヒンジピン	1
14	160001	Screw (M4 -0.7×4)	止ネジ	1
15	2100755	Presser Foot Release Lever Stop	手揚ゲストップ	1
16	110068	Screw (M4 -0.7×8)	止ネジ	1
17	下表参照	Presser Foot, C. Set	押工 (組)	1
18	2157004	Presser Foot Hinge	押工ヒンジ	1
19	110004	Screw (M3.5 -0.6×8)	止ネジ	1
20	2157020	Presser Foot (Lower)	押工 (下)	1
21	2157205	Presser Foot Stich Tongue (Y5)	爪	1
22	2157030	Finger Guard	フィンガガード	1
23	000444	Washer	ワッシャ	1
24	005036	Screw (1/8 -44×5.6)	止ネジ	1
25	2157035	Thread Chain Guide	空環ガイド	1
26	001230	Screw (3/32 -56×3.8)	止ネジ	1
27	2157036	Presser Foot Spring Setting Piece	押工バネ取付片	1
28	110054	Screw (M3 -0.5×3.5)	止ネジ	1
29	280008	Screw (3/32 -56×1.8)	止ネジ	2
30	22261	Presser Foot Spring	押工バネ	1

Model Name	Floating Presser Foot, C. Set	Parts included in Floating Presser Foot, C. Set	Ref. No. 17 Presser Foot, C. Set	Stitch Plate	Differential Feed Dog	Main Feed Dog	Partial Feed Dog	Needle Clamp	Upper Looper
AZ8062G-Y5	2159915	Ref. No.2 · 15 · 16 · 17	2157147	2108004	2109005	2109006	2109067	2159102	2109322
AZ8069G-Y5	"	"	"	2108106	2109038	"	2109052	"	"

4. Parts List

AZ8560G

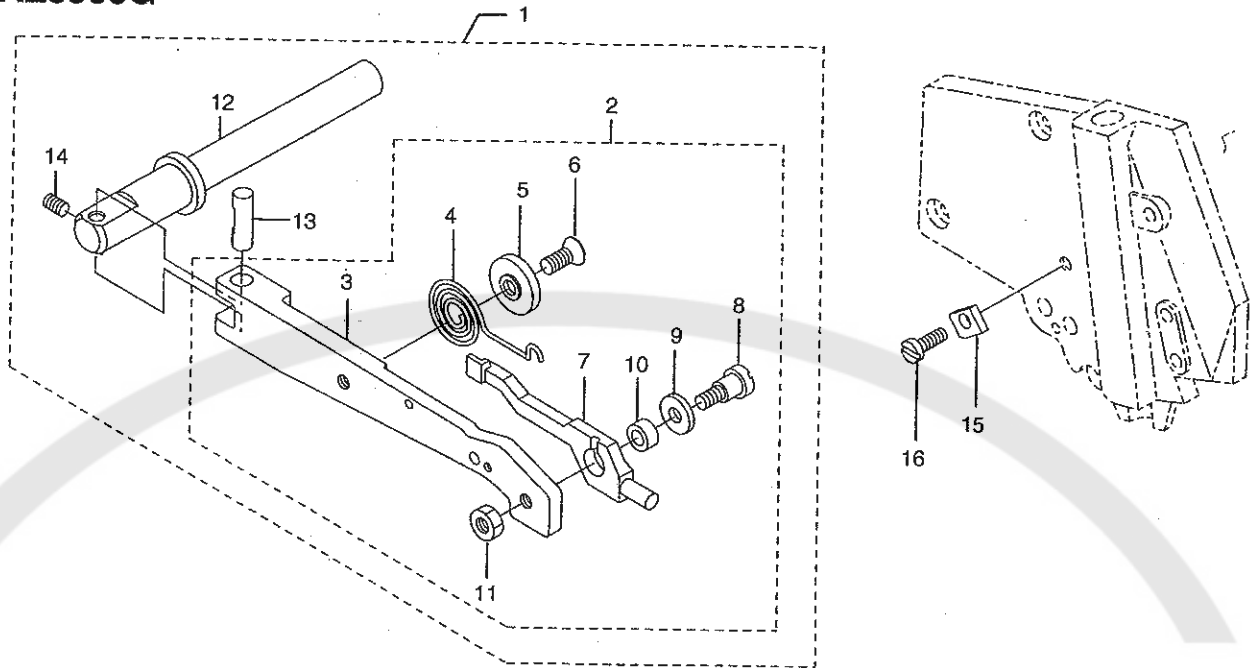

AZ8560G-A4

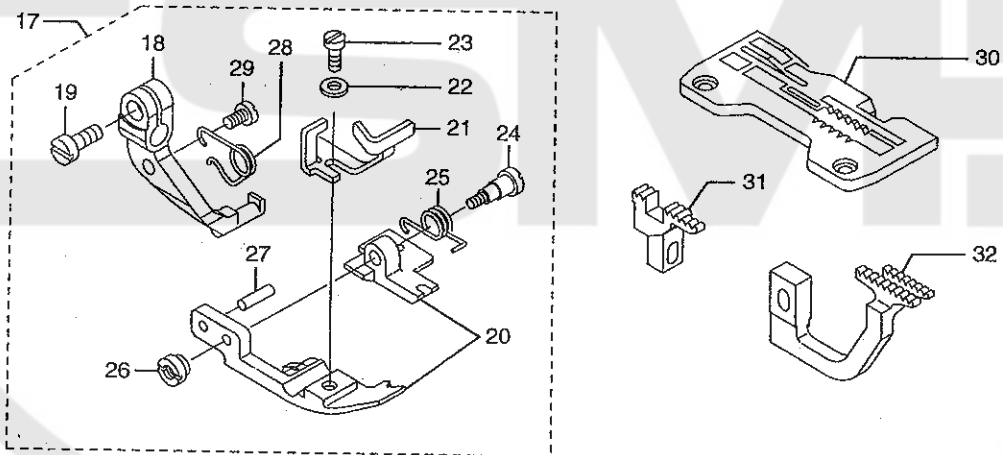

AZ8560G-C5

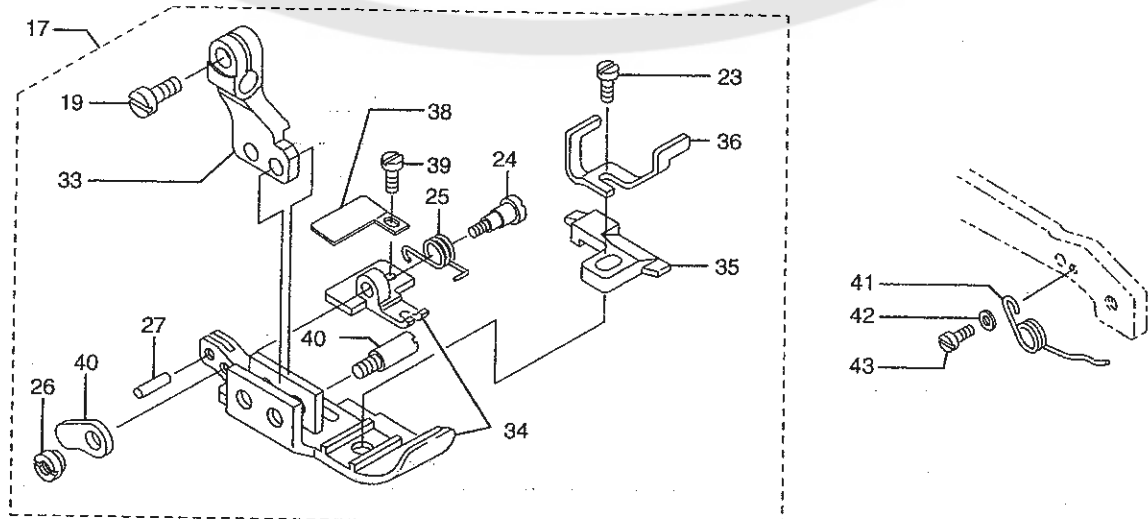

AZ8560G EXCLUSIVE PARTS サブモデル専用部品

Ref.No.	Parts NO.	Description	品名	Amt. Req.
1	2150190	Presser Arm, C. Set	押工腕 (組)	1
2	2150193	Floating Presser Arm, C. Set	フローティングアーム (組)	1
3	2150191	Presser Arm	押工腕	1
4	2100750	Adjusting Spring	調節バネ	1
5	2100751	Locking Disc	回り止め	1
6	130010	Screw (M4 -0.7×8.3)	止ネジ	1
7	2150192	Floating Presser Arm	フローティングアーム	1
8	170039	Screw (M4 -0.7×12)	止ネジ	1
9	300000	Washer	ワッシャ	1
10	2100752	Bushing	ブッシュ	1
11	100001	Nut	ナット	1
12	2100189	Presser Foot Shaft	押工軸	1
13	2100199	Presser Arm Hinge Pin	押工腕ヒンジピン	1
14	160001	Screw (M4 -0.7×4)	止ネジ	1
15	2100755	Presser Foot Release Lever Stop	手揚ゲストッパ	1
16	110068	Screw (M4 -0.7×8)	止ネジ	1
17	下表参照	Presser Foot, C. Set	押工 (組)	1
18	2157355	Presser Foot Hinge	押工ヒンジ	1
19	110004	Screw (M3.5 -0.6×8)	止ネジ	1
20	2107692	Presser Foot (Front/Rear) Unit (A4)	押工 (前・後) (組)	1
21	2107642	Presser Foot Hinge Spring	押工ヒンジバネ	1
22	000444	Washer	ワッシャ	1
23	005036	Screw (1/8 -44×5.6)	止ネジ	1
24	006093	Screw (3/32 -56×5.6)	止ネジ	1
25	0025035	Presser Foot Spring (Small)	押工バネ (小)	1
26	000216	Nut	ナット	1
27	000747	Pin	ピン	1
28	2157306	Presser Foot Spring (Large)	押工バネ (大)	1
29	110085	Screw (M3 -0.5×4.5)	止ネジ	1
30	2108135	Stitch Plate (A4)	針板	1
31	2106015	Main Feed Dog (A4)	後送り	1
32	2106014	Differential Feed Dog (A4)	前送り	1
33	2157356	Presser Foot Hinge	押工ヒンジ	1
34	2107412	Presser Foot (Front/Rear) Unit (C5)	押工 (前・後) (組)	1
35	2107105	Presser Foot Stitch Tongue (C5)	爪	1
36	2107163	Presser Foot Adjusting Plate	押工調節板	1
37	004136	Screw (1/8 -44×2.7)	止ネジ	1
38	0020501	Thread Chain Guide (C)	空環ガイド	1
39	004141	Screw (3/32 -56×2.1)	止ネジ	1
40	0033529	Presser Foot (Rear) Adjusting Plate	押工調節片	1
41	2107699	Presser Foot Spring (Large)	押工バネ (大)	1
43	004404	Screw (3/32 -56×5.1)	止ネジ	1
42	000531	Washer	ワッシャ	1

Model Name	Floating Presser Foot, C.Set	Parts included in Floating Presser Foot, C. Set	Ref. No. 17 Presser Foot, C. Set	Stitch Plate	Differential Feed Dog	Main Feed Dog	Partial Feed Dog	Needle Clamp	Upper Looper
AZ8560G-A4	2159920	Ref. No. 2-15-16-17-30-31-32	2157365	(2108135)	(2106014)	(2106015)	2109052	2159111	2109320
AZ8560G-C5	2159921	Ref. No. 2-15-16-17-41-42-43	2157366	2108076	2109055	2109056	〃	2159112	〃

4. Parts List

AZ8062G・AZ8069G EXCLUSIVE PARTS サブモデル専用部品

Ref.No.	Parts NO.	Description	品名	Amt. Req.
1	2150220	Presser Arm, C. Set	押工腕 (組)	1
2	2150223	Floating Presser Arm, C. Set	フローティングアーム (組)	1
3	2150221	Presser Arm	押工腕	1
4	2100750	Adjusting Spring	調整バネ	1
5	2100751	Locking Disc	回り止め	1
6	130010	Screw (M4-0.7×8.3)	止ネジ	1
7	2150222	Floating Presser Arm	フローティングアーム	1
8	170039	Screw (M4-0.7×12)	止ネジ	1
9	300000	Washer	ワッシャ	1
10	2100752	Bushing	ブッシュ	1
11	100001	Nut	ナット	1
12	2100189	Presser Foot Shaft	押工軸	1
13	2100189	Presser Arm Hinge Pin	押工腕ヒンジピン	1
14	160001	Screw (M4-0.7×4)	止ネジ	1
15	2100755	Presser Foot Release Lever Stop	手擺げストップ	1
16	110068	Screw (M4-0.7×8)	止ネジ	1
17	下取参照	Presser Foot, C. Set	押工 (組)	1
18	2157004	Presser Foot Hinge	押工ヒンジ	1
19	110004	Screw (M3.5-0.6×8)	止ネジ	1
20	2157020	Presser Foot (Lower)	押工 (下)	1
21	2157205	Presser Foot Stitch Tongue (Y5)	爪	1
22	2157030	Finger Guard	フィンガガード	1
23	000444	Washer	ワッシャ	1
24	005036	Screw (1/8-44×5.6)	止ネジ	1
25	2157035	Thread Chain Guide	空環ガイド	1
26	001230	Screw (3/32-56×3.8)	止ネジ	1
27	2157036	Presser Foot Spring Setting Piece	押工バネ取付片	1
28	110054	Screw (M3-0.5×3.5)	止ネジ	1
29	280008	Screw (3/32-56×1.8)	止ネジ	2
30	22261	Presser Foot Spring	押工バネ	1

Model Name	Floating Presser Foot, C. Set	Parts included in Floating Presser Foot, C. Set	Ref. No. 17 Presser Foot, C. Set	Stitch Plate	Differential Feed Dog	Main Feed Dog	Partial Feed Dog	Needle Clamp	Upper Looper
AZ8062G-Y5	2158915	Ref. No. 2・15・16・17	2157147	2108004	2108005	2108006	2108067	2155102	2108322
AZ8069G-Y5	*	*	*	2108106	2108038	2108052	*	*	*

