

**Illustrated Parts for Machine Style 54200J-12-16
(Supplement to Catalog 102L and Adjusting Manual INS9203)**

Manual No. PRT9204

First Edition Copyright 1992

By

Union Special Corporation

Rights Reserved In All Countries

Printed in U.S.A. September, 1992

APPLICATION OF MANUAL

This manual is a supplement to Catalog 102L and Adjusting Manual INS9203 and should be used in conjunction there with.

Only new parts found on Style 54200J-12-16 are illustrated. Use catalog 102L for parts not illustrated or described in this manual. Reference numbers that are inside a bracket or box on the illustrated page and have indented descriptions indicate they are component parts of a complete part or sub-assembly.

For clarity, certain parts are shown in phantom to help locate the new 54200J-12-16 parts.

NEEDLES

Each Union Special needle has both a type and size number. The type number denotes the kind of shank, point, length, groove, finish and other details. The size number, stamped on the needle shank, denotes the largest diameter of the blade midway between the shank and the eye. Collectively, the type number and size number represent the complete symbol which is given on the label of all needles packed and sold by Union Special.

The standard needle for the 54200J-12-16 is Type 113GS Size 125/049.

Type	Description	Sizes Available	
113 GS	Round shank, round point, extra short, double groove, spiral groove, struck groove, ball eye, spotted, chromium plated	075/029	110/044
		080/032	125/049
		090/036	140/054
		100/040	

Needle orders will be promptly and accurately filled when a sample needle, an empty needle package or the type and size number of the needle is forwarded. The type and size number of the needle is located on the needle package label. A complete order would read as follows: "1000 needles, Type 113GS, Size 100/040".

REPAIR PARTS

Implementation of preventative maintenance procedures can bring significant improvements in operator productivity by avoiding costly equipment breakdowns. Wherever it becomes necessary to make repairs or replace parts on your machine, be sure to insist on genuine UNION SPECIAL repair parts. These parts are designed specifically for your machine and manufactured with utmost precision to assure long lasting service.

IDENTIFYING PARTS

Where construction permits, each part is stamped with its part number. On some of the similar parts and on those where construction does not permit, an identification letter is stamped into the part to distinguish it from similar ones.

Part numbers represent the same part, regardless of which manual they appear. On all orders please include part number, name and style of machine for which the part was ordered.

TERMS

Prices are strictly net cash and are subject to change without notice. All shipments are forwarded F.O.B. shipping point. Parcel Post shipments are insured unless otherwise directed. A charge is made to cover postage and insurance.

OILING

The oil has been drained from the machine before shipping and the reservoir must be filled before beginning to operate. Use a straight mineral oil, Saybolt viscosity of 90 to 125 seconds at 100° Fahrenheit.

Run the machine slowly for a few minutes to allow the wicks to carry oil to the bearings. The puller drive shaft bushing and the puller connecting link must be oiled by hand.

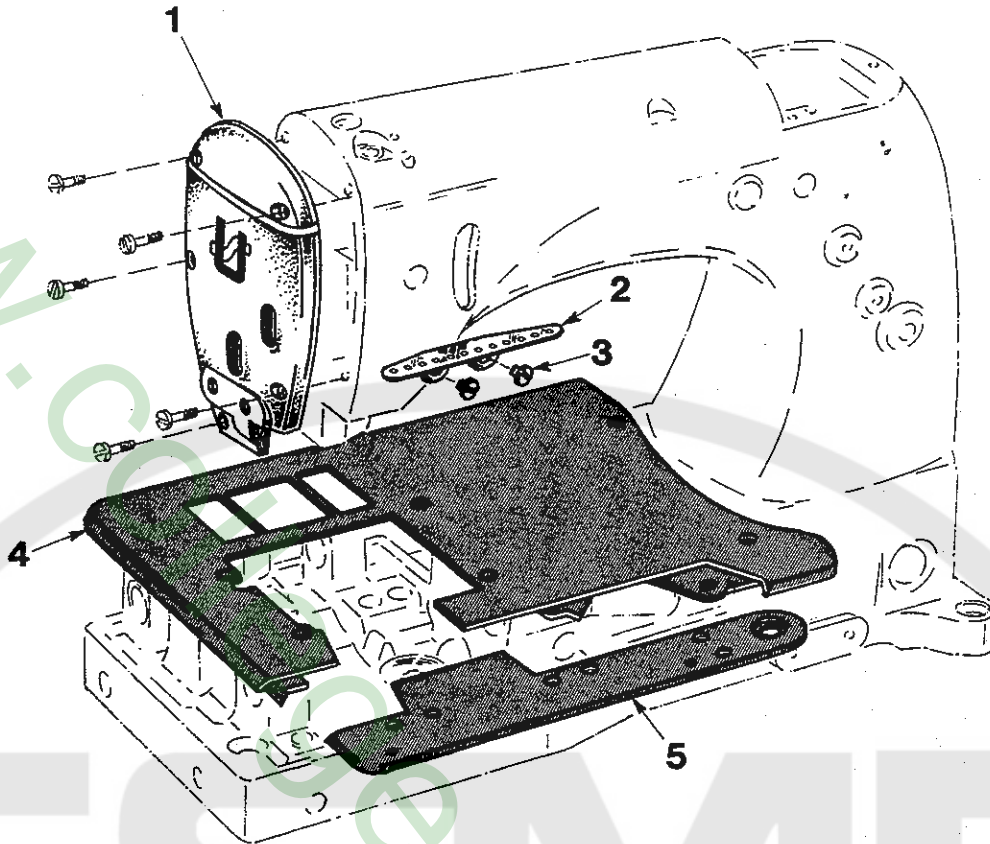

P041-92

MISCELLANEOUS COVERS

Ref. No.	Part No.	Description	Amt. Req.
1	54282 AA	Head Cover	1
2	54258 A-12-16	Needle Frame Eyelet	1
3	22561	Screw, needle thread eyelet	2
4	54201 F	Cloth Plate	1
5	54464 A	Folder Mounting Bracket	1

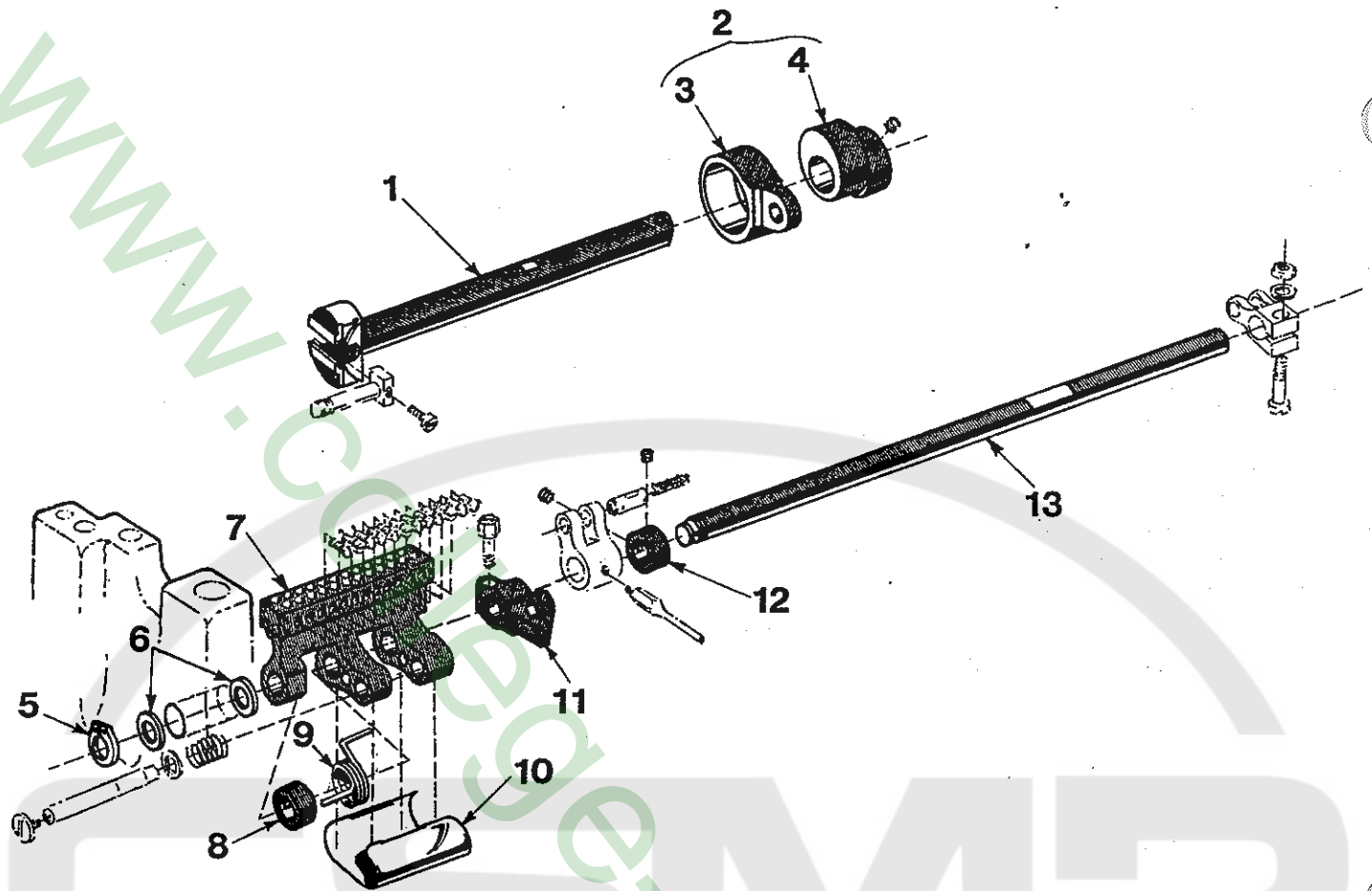

P042-92

MAIN SHAFT & MISCELLANEOUS LOOPER PARTS

Part No.	Description	Amt. Req.
1	54222 H Main Shaft	1
2	29133 R Looper Drive Eccentric Assembly	1
3	61285 G Pump Eccentric Strap	1
4	54243 D Feed Eccentric	1
5	660-891 C "C" Ring, for looper rocker shaft	1
6	54242 L Thrust Washer	2
7	54244 T Looper Holder	1
8	24244 Y Collar, for looper throw-out spring	1
9	54244 X Looper Throw-Out Spring	1
10	54244 V Looper Holder Frame Thread Shield	1
11	54244 W Looper Holder Driving Arm	1
12	54244 Y Collar	1
13	51244 K Looper Rocker Shaft	1

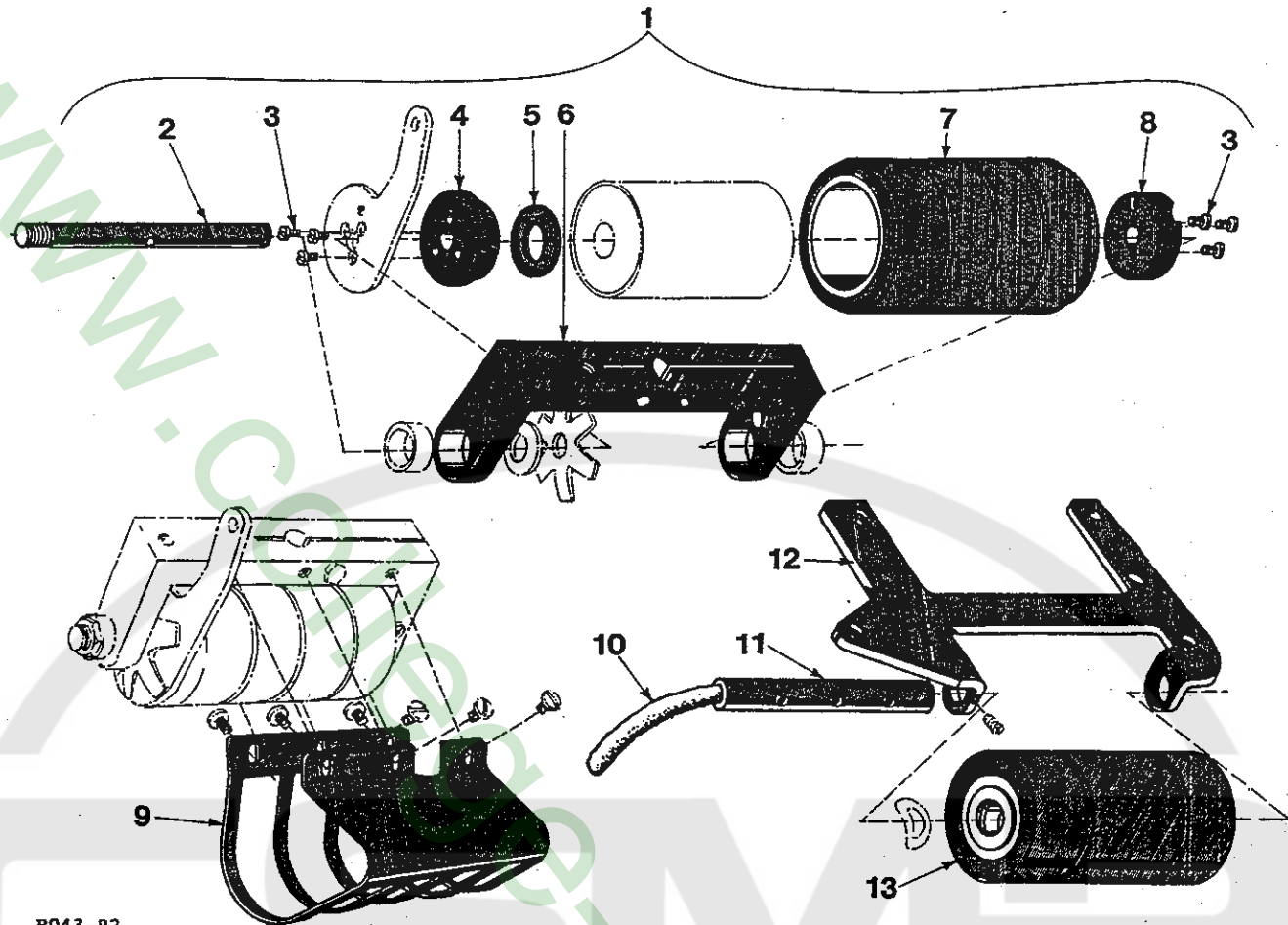

P043-92

FEED ROLLER CLUTCH ASSEMBLY & LOWER ROLLER PARTS
(As viewed from rear of machine)

Ref. No.	Part No.	Description	Amt. Req.
1	29476 RG	Feed Roller Clutch Assembly	1
2	54274 AC	Clutch Shaft	1
3	22797 B	Screw	6
4	54274 AB	Clutch Spacer, right	1
5	54274 AD	Spacer	1
6	54278 AE	Feed Roller Yoke	1
7	54275 N	Upper Feed Roller	1
8	54274 AA	Clutch Spacer, left	1
9	54276 Y	Feed Roller Guard	1
10	666-326	Oil Wick	1
11	54276 AA	Lower Feed Roller Shaft	1
12	51280 P	Throat Plate and Lower Feed Roller Support	1
13	54276 AB	Lower Feed Roller, rubber	1

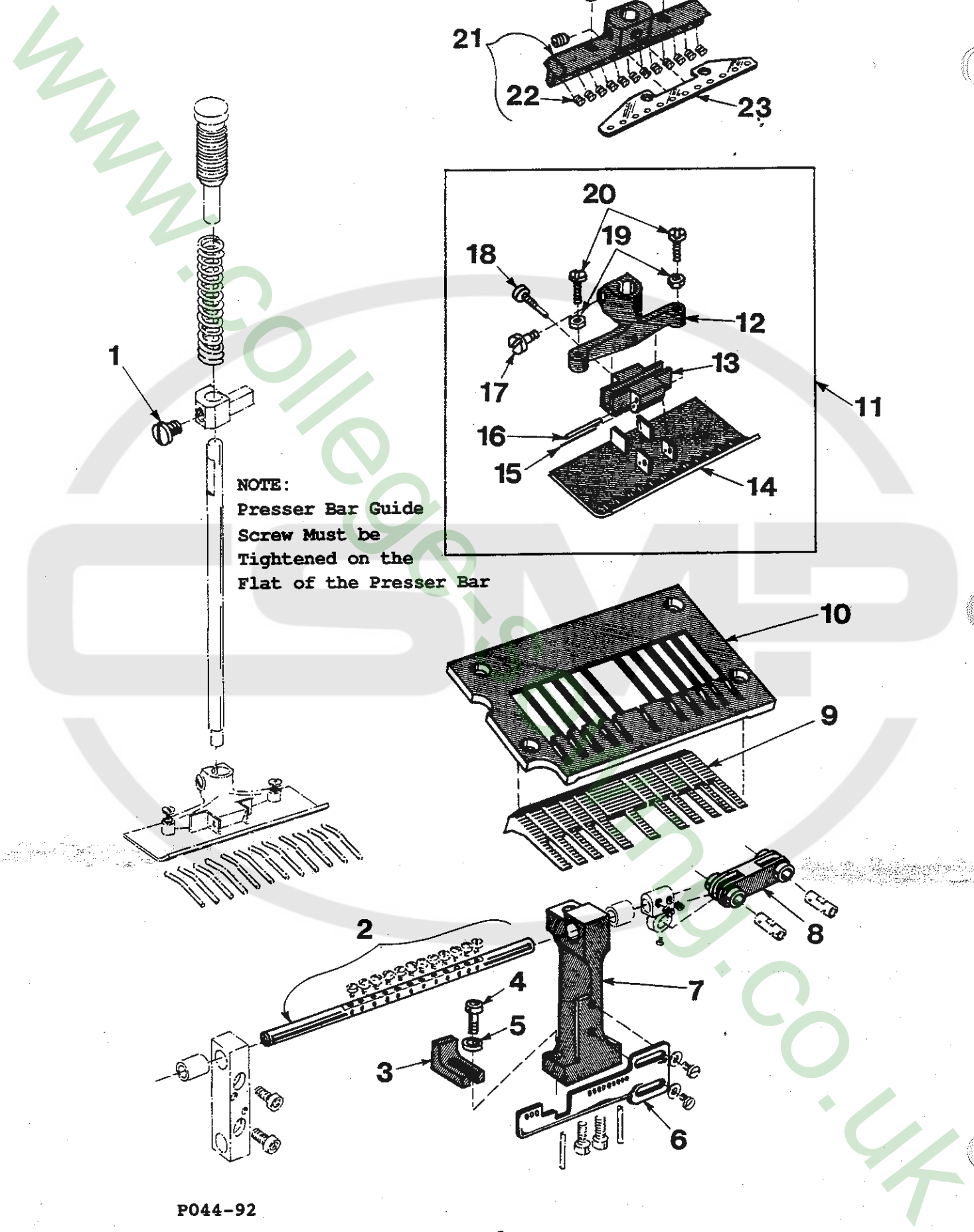

NOTE:
Presser Bar Guide
Screw Must be
Tightened on the
Flat of the Presser Bar

RETAINER HOLDER, FEED DOG, THROAT PLATE & PRESSER FOOT PARTS

Ref. No.	Part No.	Description	Amt. Req.
1	94	Screw, presser bar guide	1
2	54242 A-12-16	Retainer Holder	1
3	54244 Z	Looper Holder Rest	1
4	22653 B-8	Screw, looper holder rest	1
5	8372 A	Washer, looper holder rest screw	1
6	54259-12	Looper Thread Eyelet	1
7	54254 G	Looper Holder Bearing	1
8	54254	Retainer Drive Lever Link	1
9	54205 A-12-16	Feed Dog	1
10	54224 B-12-16	Throat Plate	1
11	54220 J-12-16	Presser Foot, complete	1
12	54230 G	Shank	1
13	54230 H	Hinge	1
14	54230 F	Base	1
15	660-219 AF	Roll Pin	1
16	660-219 A	Roll Pin	1
17	22839	Screw, shank	1
18	22747 C	Screw, hinge	1
19	43443 Q	Nut, shank	2
20	22747 B	Screw, shank	2
21	54218 B-12-16	Needle Head	1
22	22560	Screw	12
23	54258-12-16	Needle Head Eyelet	1

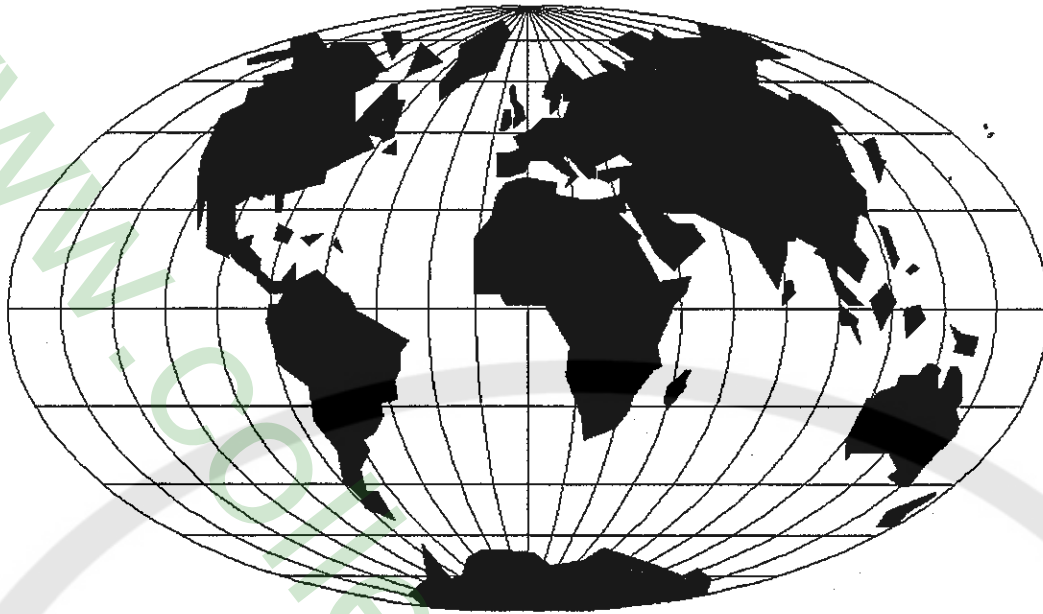

WORLDWIDE SALES AND SERVICE

Union Special Corporation maintains sales and service facilities throughout the world. These offices will aid you in the selection of the right sewing equipment for your particular operation. Union Special Corporation representatives and service technicians are factory trained and are able to serve your needs promptly and efficiently. Whatever your location, there is a qualified representative to serve you.

Corporate Office: One Union Special Plaza
Huntley, IL 60142
Phone: 847•669•5101
Fax: 847•669•4454

European Distribution Center: Union Special GmbH
Raiffeisenstrasse 3
D-71696 Möglingen, Germany
Tel: 49•07141•247•0
Fax: 49•07141•247•100

Brussels, Belgium
Charlotte, N.C.
Hong Kong, China
Huntley, IL
Leicester, England
Lille, France
Miami, FL
Milan, Italy
Möglingen, Germany
Montreal, Quebec
Osaka, Japan
Santa Fe Springs, CA
Suwanee, GA
Wayne, NJ

Other Representatives throughout all parts of the world.

Weitere Vertretungen in allen Teilen der Welt.

Union Special unterhält Verkaufs- und Kundendienst-Niederlassungen in der ganzen Welt. Diese helfen Ihnen in der Auswahl der richtigen Maschine für Ihren speziellen Bedarf. Union Special Vertreter und Kundendiensttechniker sind in unseren Werken ausgebildet worden, um Sie schnell und fachmännisch zu bedienen.

Finest Quality

Union Special
INDUSTRIAL SEWING EQUIPMENT