

JUKI



LZ-2280A Series

High-speed, 1-needle, Lockstitch, Zigzag Stitching Machine

The machine produces
high-quality soft seams.



High-speed, 1-needle, Lockstitch,
Zigzag Stitching Machine

LZ-2280A
Series

LZ-2280A Series

LZ-2280A Series is the latest model of highly-evaluated JUKI's zigzag stitch machines.

The sewing machine produces soft seams with consistency with a low tension applied to the thread.

Problems which are associated with low-tension sewing such as "double-catching" and "irregular stitches", as well as factors which affect seam quality such as "thread path", "thread bending resistance", "feed locus", "needle locus" and "timing" have been thoroughly reviewed, thereby successfully producing soft seams. The machine has adopted JUKI's established genuine hook and thread take-up lever.



1 Presser adjustment screw add scale line

Presser adjustment screw attached the scale line at standard.

2 Screw for the attachment is provided as standard

The machine is provided as standard with a screw which is necessary for attaching the guide device. This facilitates response to various processes.

3 Bobbin thread winder

The bobbin thread winder is built-in at the top surface of the machine head. The bobbin winder incorporates a thread cutting knife for cutting the thread after the completion of bobbin winding.

4 Micro-lifter

It works to constantly material or other difficult-to-sew ones, thereby helping effectively reduce material slippage as well as damages made by the presser foot on the material.

5 The compact-size servomotor *

The LZ-2284A-7 has installed with the compact servomotor which has directly connected to the main shaft.

*Applied only to 00, 0B and models with automatic thread trimmer

6 Silent and low-vibration operation

The needle rocking cam has been totally reviewed to enable comfortable sewing even during high-speed sewing.

7 Easy-to-operate adjustment mechanism

For the adjustment of the needle position, needle throwing width and stitch base line, an easy-to-operate lever style has been adopted. In addition, the feed amount and the condensation mechanism for fastening stitches can be easily adjusted since an adjustment dial has been adopted.

8 The lift of the presser foot has been increased and the LED has been provided as standard *

The visible area around the needle entry point has been increased and the LED light has been installed, thereby helping reduce the operator's fatigue when sewing small parts. The illuminance of the LED light can be adjusted near the needle entry point.

*LED : Applied only to 00, 0B and models with automatic thread trimmer

9 Automatic reverse feed function

The automatic reverse feed switch can be re-positioned to best match the operator.

10 Attachment-mounting seat

Installation of an attachment-mounting seat improves operability when replacing the attachment and increases the durability of the machine bed surface.

JUKI ECO PRODUCTS



The LZ-2284A-7 is an eco-friendly product which complies with JUKI ECO PRODUCTS standards for protecting the environment.

- The sewing machine complies with the "Juki Group Green Procurement Guidelines" on the use of hazardous substances, which is stricter than other restrictions, such as those of the RoHS Directive.
- This sewing machine reduces power consumption by 8.6% as compared with the conventional models**.

For details of JUKI ECO PRODUCTS, refer to : http://www.juki.co.jp/eco_e/index.html

*The RoHS Directive is an EU Directive limiting the use of 6 hazardous substances (lead, hexavalent chromium, mercury, cadmium, PBB and PBDE) in electrical and electronic equipment. The Juki Green Procurement Guideline is the voluntarily established criteria to eliminate not only the aforementioned six substances, but also other ones which also adversely affect the environment.

**Compact AC servomotor (direct-drive system)

Standard zigzag stitching machine

Standard / Standard wider zigzag

High-speed, 1-needle, Lockstitch,
Zigzag Stitching Machine

LZ-2280A

The standard zigzag stitching machine creates softly finished seams. The needle rocking mechanism is provided with a triangular cam which helps produce beautiful seams with consistency.



LZ-2280A

Two kinds of gauges can be selected in accordance with the application of the machine: an A-type gauge with a zigzag width of 5 mm, and a B-type gauge with a zigzag width of 8 mm.

Zigzag width: 5 mm

High-speed, 1-needle, Lockstitch,
Zigzag Stitching Machine

LZ-2280AA



Zigzag width: 8 mm

High-speed, 1-needle, Lockstitch,
Standard wider zigzag stitching machine

LZ-2280AB



JUKI's unique thread trimming mechanism

JUKI-specific loop spreading-structure knife sliding system enables thread trimming without fail whether needle throws to the right or the left.

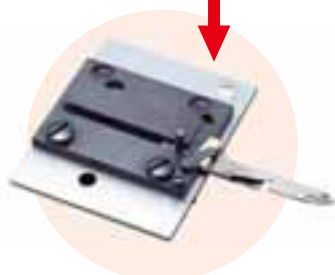

Maintenance

- The adjustable range of the feed mechanisms has been widened, thereby upgrading the machine's responsiveness to materials

Inclination of the feed dog

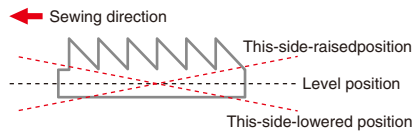

The feed mechanism has been improved by widening the adjustable range of the height and inclination of the feed dog. The feed locus has been optimized while placing great emphasis on the feed locus at the moment the needle penetrates the material to form a stitch. The weight of the feed mechanism has been reduced by using parts most of which are made of aluminum material. This facilitates sewing of overlapped sections of material that have to be securely held between the presser foot and the feed dog during sewing.

- Adjustment for various feed timings

Marker lines engraved on the face plate and the pictorial indication facilitate adjustment of the needle-to-feed timing and the hook timing.



- Adjustment of oil quantity in the hook

Oil feeding path of the LZ-2280A Series has been reviewed to enable feeding of consistent quantity of oil.

Stitching Pattern Changeover Function

Equipped with two different functions, the machine is available to handle a wider range of application

LZ-2284A (Standard/3-step Zigzag) and LZ-2287A (3-step Zigzag/Scallop) can perform two stitching patterns by one machine, thereby increasing the machine operation rate.

Standard/3-step Zigzag Stitching Pattern Changeover Function

High-speed, 1-needle, Lockstitch, Zigzag Stitching Machine

LZ-2284A-7 LZ-2284A

Switch between the standard zigzag stitching pattern and 3-step zigzag stitching pattern with simple one-touch control

The operator can easily switch the needle-throwing pattern between the standard and 3-step zigzag stitching patterns using the lever located in the free space under the arm. When changing the sewing product or design, there's no need to adjust the sewing machine head or machine layout.



LZ-2284A-7/CP-180A

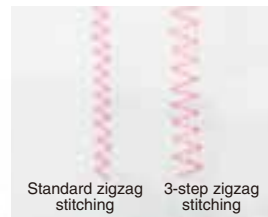

Switch between the 3-step zigzag stitching pattern and scallop stitching pattern with simple one-touch control

The world's fastest

High-speed, 1-needle, Lockstitch, Zigzag Stitching Machine

LZ-2287A

3-step zigzag stitching and scallop stitching can be changed over through fingertip control

The mechanism for changing over the type of stitching between standard zigzag stitching and 3-step zigzag stitching has been well-received in the market. Now, the sewing machine which is able to change over the type of stitching between 3-step zigzag stitching and scallop stitching which are frequently used for sewing girdles has been added to the LZ Series.



LZ-2287A

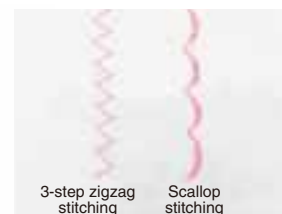

Options

Part No.	Description	Feature
40135177	Automatic reverse feed Kit	This device allows a machine without thread trimmer to perform automatic reverse feed function.
225-26578	Hook with a hard blade point	Prevents the blade point of the hook from wearing out
229-07406	Presser spring	This is the spring which strongly holds down the material when sewing a heavy weight material.
B3129012A00	Tension spring	Tightly tensed seams can be produced by increasing the tension applied to the needle thread.
40135178	Auxiliary Thread take-up Kit	Thread breakage and stitch skipping can be prevented by stabilizing the needle thread loops.

● Hook with non-rotational bobbin

The hook with non-rotational bobbin eliminates sewing troubles resulting from bobbin idling. It provides a uniform bobbin thread tension at all times, thereby guaranteeing a consistent stitch formation.



235-23152 Hook
235-22550 Bobbin case (asm.)
235-23004 Bobbin

Application	Mainly for the standard zigzag stitch: Effectively prevents the material swelling at the sewn part, as well as irregular stitches when sewing lace to slips, camisoles and shorts.
Precaution	The quantity of thread to be wound around this bobbin is approximately 60% of that wound around the conventional bobbin. Therefore, this bobbin is not recommended for pattern stitching such as three-point zigzag stitching and scallop stitching, or intape-attaching processes, even if the stitch system is the standard zigzag stitch.
Applicable thread	Thread specifically developed for sewing foundation garments and lingerie such as Resilon, Poelon, Satin, and Berlon (#50, #60)
Not-applicable thread	Thread which has naps, decorative yarn of multi-fiber thread such as woolly thread, Berlon D420 and D300, and spun thread

* If you want to use a non-rotational bobbin, consult your distributor beforehand.

● Oilless bobbin case / Hook (special race surface plastic hook)

The oilless bobbin case and hook effectively prevent oil stains.

* When using the oilless bobbin and hook, a hook driving shaft front setscrew (part number: 110-79506) is necessary.



235-57259 Hook compl. D
400-03609 Bobbin case D3 (compl.)
400-03610 Bobbin case D3 (asm.)

● Hook gib

Soft seams can be produced by lowering the bobbin thread tension.



400-16408 Hook gib VS

● Parts for sewing with thick thread (recommended needle: DP×5 #21, 134SUK Nm130)



225-56054 Knife unit
D1440-583-H00 Needle thread guide
400-17095 Thread tension disk (asm.)
225-80369 Presser foot (asm.)

● Pedal-operated reverse feed stitching device (RF-1)

The device enables the operator to perform reverse feed stitching using the pedal without using the right hand.

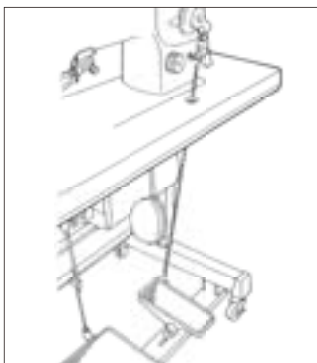

GRF010000B0 (asm.)





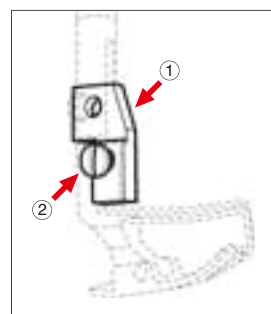





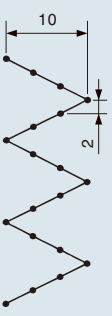
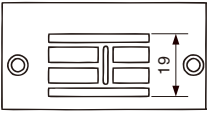

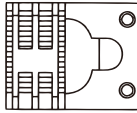
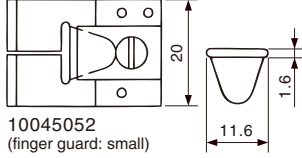
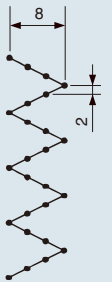
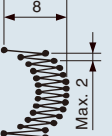

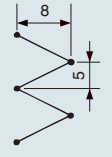
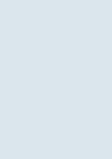
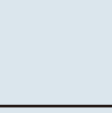
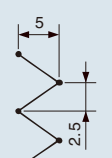
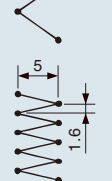
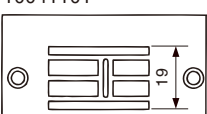

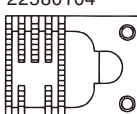
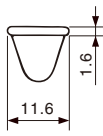
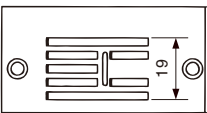

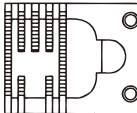
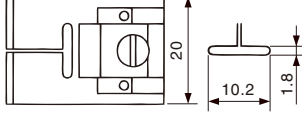
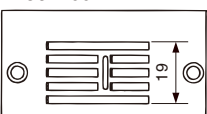

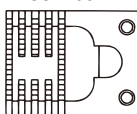
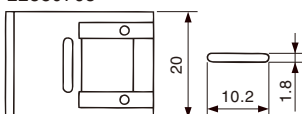
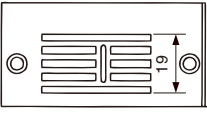
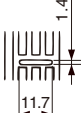
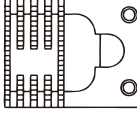
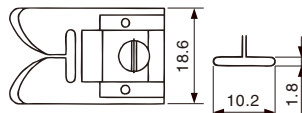
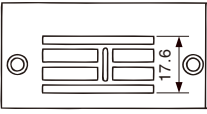
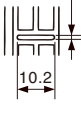
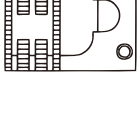
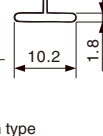
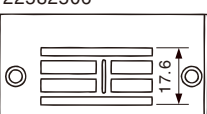

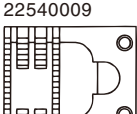
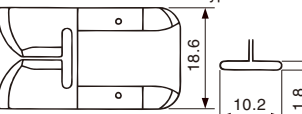
● Presser foot connecting components

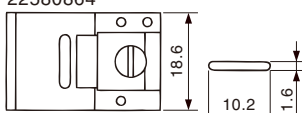
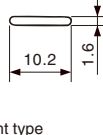
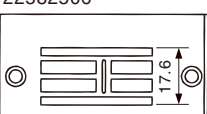

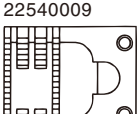
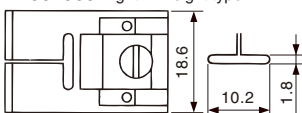
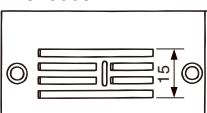

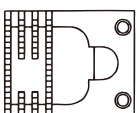
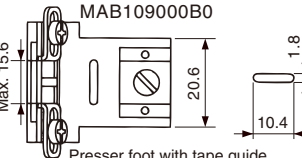
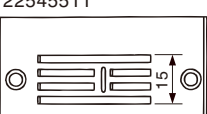

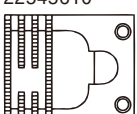
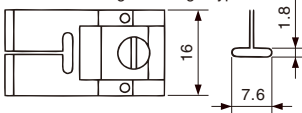
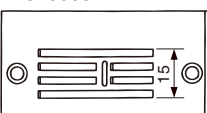

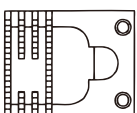
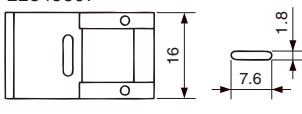

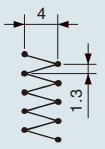
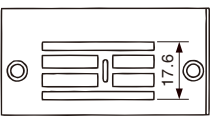

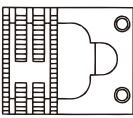

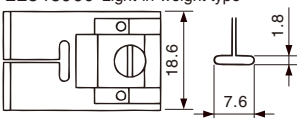
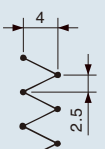
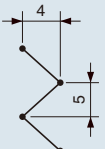
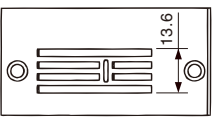

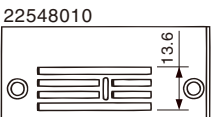

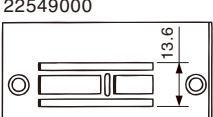
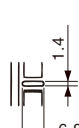
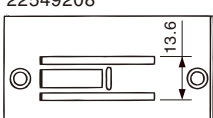
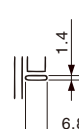
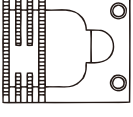

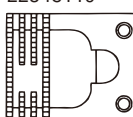
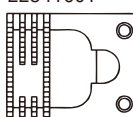

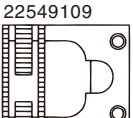
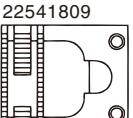

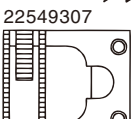
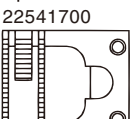
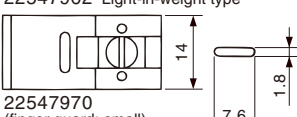
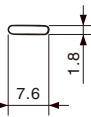
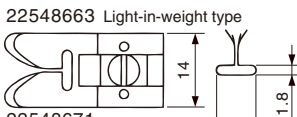
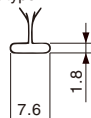
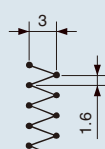
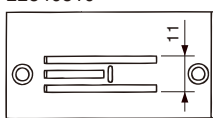

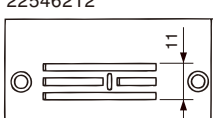
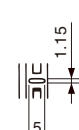
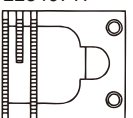
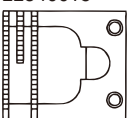
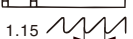

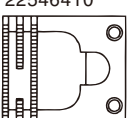
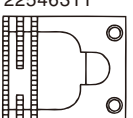
The aforementioned parts are used when a lockstitching type presser foot is installed on the machine. Select a parts set of either the presser-bar changing type or the presser bar joining type, according to the type of presser foot of your machine.

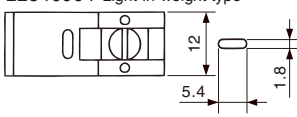
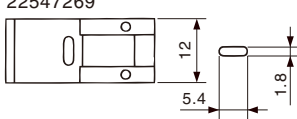
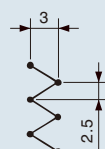
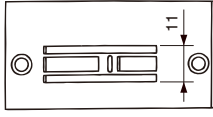

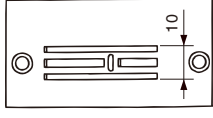
Presser foot connecting components
① B1551-586-000 Presser foot connecting foot
② SS-7090910-TP Screw

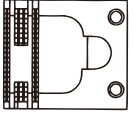

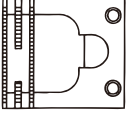

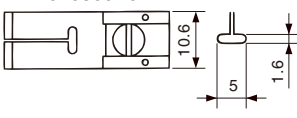
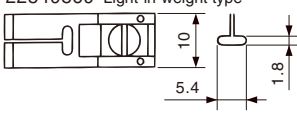
List of the major gauges

Max. zigzag width / Max. feed pitch	Throat plate	Feed dog	Presser foot (with finger guard)	Remarks
	10041010  	10047017  <p>1.6 Max. feed amount: 2mm</p>	With a recess on the reverse side of the presser foot 22580369 	<ul style="list-style-type: none"> • Suited to sewing tasks that require frequent changes in the needle throw position.         <ul style="list-style-type: none"> • Light-in-weight presser foot prevents jumping at the time of high-speed sewing.
	10041101  	22580104  <p>1.6 Max. feed amount: 2mm</p>	10045052 (finger guard: small) 	
22580005  	22580500  <p>1.15 Max. feed amount: 2mm</p>	22580260 Light-in-weight type 		
22582100  	22582209  <p>1.6 Max. feed amount: 2mm</p>	22580765 		
22582704  	22582803  <p>1.5 Max. feed amount: 2mm</p>	23503154 Light-in-weight type 		
22582407  	22581508  <p>1.5 Max. feed amount: 2mm</p>	23503162 (finger guard: small) 		
22582506  	22540009  <p>1.7 Max. feed amount: 5mm</p>	23503253 Front fulcrum type 		
22548804  	22580864 	10055051 (finger guard: small) 		
22582506  	22540009  <p>1.7 Max. feed amount: 5mm</p>	22584965 Light-in-weight type 		
22545008  	22545107  <p>1.7 Max. feed amount: 2.5mm</p>	MAB109000B0  <p>Max. 15.6 20.6 10.4 1.8</p> <p>Presser foot with tape guide</p>		
22545111  	22545610  <p>1.15 Max. feed amount: 1.6mm</p>	22545362 Light-in-weight type 		
22545008  	22545107  <p>1.7 Max. feed amount: 2.5mm</p>	22545867 		

Max. zigzag width / Max. feed pitch	Throat plate	Feed dog	Presser foot (with finger guard)	Remarks
	<p>22548705</p>  	<p>22548804</p>   <p>Max. feed amount: 1.3mm</p>	<p>22548960 Light-in-weight type</p> 	
 	<p>22548507</p>   <p>22548010</p>   <p>22549000</p>   <p>22549208</p>  	<p>22548408</p>   <p>Max. feed amount: 2.5mm</p> <p>22548119 22541601</p>   <p>Max. feed amount: 2.5mm Max. feed amount: 5mm</p>  <p>22549109 22541809</p>   <p>Max. feed amount: 2.5mm Max. feed amount: 5mm</p>  <p>22549307 22541700</p>   <p>Max. feed amount: 2.5mm Max. feed amount: 5mm</p>	<p>22547962 Light-in-weight type</p>  <p>22547970 (finger guard: small)</p>  <p>22548663 Light-in-weight type</p>  <p>22548671 (finger guard: small)</p> 	<ul style="list-style-type: none"> • For standard zigzag stitching • The 5mm-feed is suited to tape-attaching process where the elastic tape is sewn with stretched.
	<p>22546519</p>   <p>22546212</p>  	<p>22546717 22546618</p>     <p>22546410 22546311</p>    	<p>22546964 Light-in-weight type</p>  <p>Light-in-weight type with the front fulcrum</p> <p>22547269</p> 	
	<p>MAD04060000</p>   <p>22549604</p>  	<p>MAD04070000</p>   <p>22549703</p>  	<p>MAD040500A0</p>  <p>22549869 Light-in-weight type</p> 	<ul style="list-style-type: none"> • For attaching tape to brassieres, etc.

• In addition to the above-listed ones, many different gauges and attachments for zigzag stitching are available. Please contact us for details.

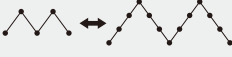
SPECIFICATIONS

Model name	Without automatic thread trimmer	LZ-2280A (A)	LZ-2280A (B)	LZ-2284A	LZ-2287A
	With automatic thread trimmer	—	—	LZ-2284N-7	—
Stitch system		Standard zigzag	Standard wider zigzag	Standard / 3-step zigzag	3-step zigzag / scallap
Stitch pattern					
Max. sewing speed		5,000 sti/min			
Max. zigzag width		5 mm	8 mm	5 mm (standard) 10 mm (3-step)	10 mm
Max. feeding amount		2.5 mm	5 mm	2.5 mm	2.5 mm
Lift of the presser foot		By hand: 5.5 mm, By knee: 10 mm			
Hook		DP hook (with titanium-treated inner hook)			
Thread take-up		Rotary type			
Lubrication		Fully automatic			
Lubricating oil		JUKI New Defrix Oil No.1 (equivalent to ISO VG7)			
Needle (at the time of delivery)		134SUK (Nm70)			
Needle position changing mechanism		Provided as standard			
Reverse feed stitching mechanism		Provided as standard			
Needle throw pattern cam		Triangular cam		Grooved cam	

*sti/min stands for Stitches per Minute.

WHEN YOU PLACE ORDERS

Please note when placing orders, that the model name should be written as follows:

- LZ-2280A series (without automatic thread trimmer)

LZ228

Type	Code	Automatic reverse feed function	Code
Standard wider zigzag (with a gauge for 5mm zigzag width)	0AA	Not provided	
Standard wider zigzag (with a gauge for 8mm zigzag width)	0AB	without automatic reverse feed function	00
Standard/3-step zigzag	4A	with automatic reverse feed function	0B
Standard/3-step zigzag (with anti-material-slip type)	4AT	* '0B' is applied only to LZ-2284A and 2284AT * '0B' and '00' are Direct-Drive head	
3-step zigzag / scallap	7A		

- LZ-2280A-7 series (with automatic thread trimmer)

LZ2284A7WB

Type	Code	Wiper and automatic reverse feed function		Auto-lifter	Code
Standard / 3-step zigzag	4A	Wiper	Automatic reverse feed function	Not provided	
		Provided	Provided	Provided	AK

- Control box

SC-920A

- Operation panel

CP18A
CP180A

To order, please contact your nearest JUKI distributor.



JUKI CORPORATION HEAD OFFICE

Juki Corporation operates an environmental management system to promote and conduct the following as the company engages in the research, development, design, sales, distribution, and maintenance of industrial sewing machines, household sewing machines, industrial robots, etc., and in the provision of sales and maintenance services for data entry systems:

- (1) The development of products and engineering processes that are safe to the environment
- (2) Green procurement and green purchasing
- (3) Energy conservation (reduction in carbon-dioxide emissions)
- (4) Resource saving (reduction of papers purchased, etc.)
- (5) Reduction and recycling of waste
- (6) Improvement of logistics efficiency (modal shift and improvement of packaging, packing, etc.)

JUKI

JUKI CORPORATION
SEWING MACHINERY BUSINESS UNIT

2-11-1, TSURUMAKI, TAMA-SHI,
TOKYO 206-8551, JAPAN
PHONE : (81) 42-357-2254
FAX : (81) 42-357-2274
http://www.juki.com

- * Specifications and appearance are subject to change without prior notice for improvement.
- * Read the instruction manual before putting the machine into service to ensure safety.
- * This catalogue prints with environment-friendly soyink on recycle paper.