

For DDL-8000A

**Bird nest prevention device**

Side mounted type: JSH-8000APBNS01

Backhold type: JSH-8000APBNB01

This optional kit prevents bird nests at the start of sewing that are generated by thread trimmer. The bird nest phenomenon caused by the surplus needle thread in the first stitch not only affects the evaluation of the quality of sewn products, but also causes a decrease in productivity in the treatment manufacturing process (thread picking). We think many customers suffer from this phenomenon.

This device automatically grasps the needle thread at the start of sewing and achieves the optimum needle thread volume, thereby exerting an effect on **Improvement of sewing quality at the start of sewing** and also **Bird nest prevention**.

(Examples of sewing from the edge of fabric)

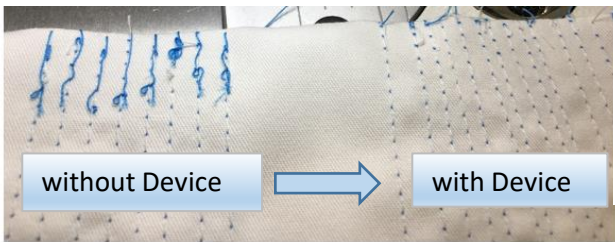

Length of remaining thread is 3mm or less!



1) Two types of mounting type are available

**【Side mounted type】**

Parts No. : JSH-8000APBNS01

This is a side-mounted type corresponding to a device such as a puller around a presser foot.



**【Backhold type】**

Parts No. : JSH-8000APBNB01

The clamp wiper is an integrated type that operates from the Backhold.



2) EASY TO INSTALL

Using DDL-8000's power source, external control box is no longer required.

[ All Parts Consists of Stop Screws Only ]

[ Complete set ]

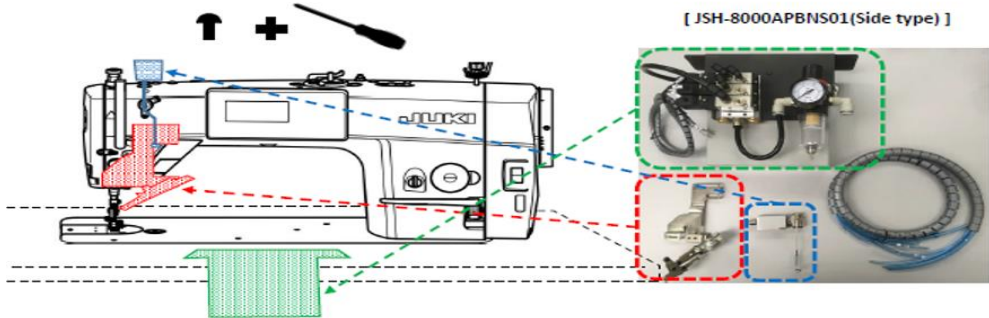

\*This device can be used in a variety of processes. (Labels/zippers/pockets/top stitches with sleeves, etc.)



LABEL



ZIPPER



POCKET



SHIRTS BOTTOM



SLEEVE



JEANS ZIPPER TOP STITCH

# - Introduction of Optional Presser foot for Bird nest prevention device -



Standard presser foot : attached as standard equipment



Presser foot with moving guide(left of right) : Option  
Size : 1/32,1/16,1/8,1/4



Presser foot with fixed guide(left or right) : Option  
Size : 1/32,1/16,3/16,1/8,1/4

\*Replacing a foot can be very easy.



\*Replacement of the central disk knife is also easy.  
The knife is rotated 360° by vibration during sewing to maintain the optimal cutting quality.  
(Disk knife parts no. : JSH-001-10.SH )

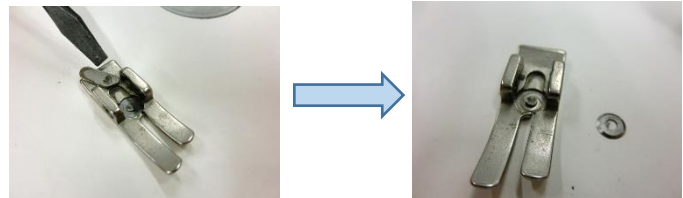

[List of Optional presser foot for Bird nest prevention device]  
(JSH-8000APBNS01/JSH-8000APBNB01)

No	PART NO	DESCRIPTION	SIZE				
			X	X1	X2	X3	Y
1	JSH-001-11A	Flat presser(Standard Presser Foot)	11	2	-	-	4.4
2	JSH-001R1-4	Presser foot with fixed guide(1/4,right)	16	2	6.4	9	4.45
3	JSH-001R1-8	Presser foot with fixed guide(1/8,right)	13	2	3.2	7	4.45
4	JSH-001R3-16	Presser foot with fixed guide(3/16,right)	16	2	4.8	9	4.45
5	JSH-001L1-4	Presser foot with fixed guide(1/4,left)	16	2	6.4	9	4.45
6	JSH-001L1-8	Presser foot with fixed guide(1/8,left)	13	2	3.2	6	4.45
7	JSH-001L3-16	Presser foot with fixed guide(3/16,left)	16	2	4.8	9	4.45
8	JSH-001R1-16	Presser foot with fixed guide(1/16,right)	13	2	1.6	7	4.45
9	JSH-001L1-16	Presser foot with fixed guide(1/16,left)	13	2	1.6	6	4.45
10	JSH-001R1-32	Presser foot with fixed guide(1/32,right)	13	2	0.8	7	4.45
11	JSH-001L1-32	Presser foot with fixed guide(1/32,left)	13	2	0.8	6	4.45
12	JSH-001AR1-16	Presser foot with moving guide(1/16,right)	13	2	-	4	4.8
13	JSH-001AR1-32	Presser foot with moving guide(1/32,right)	13	2	-	4	4.8
14	JSH-001AL1-16	Presser foot with moving guide(1/16,left)	13	2	-	4	4.8
15	JSH-001AL1-32	Presser foot with moving guide(1/32,left)	13	2	-	4	4.8
16	JSH-001AR1-4	Presser foot with moving guide(1/4,right)	16	2	6.4	9	4.8
17	JSH-001AR1-8	Presser foot with moving guide(1/8,right)	15	2	3.2	8	4.8
18	JSH-001AR3-16	Presser foot with moving guide(3/16,right)	16	2	4.8	8	4.8
19	JSH-001AL1-4	Presser foot with moving guide(1/4,left)	16	2	6.4	9	4.8
20	JSH-001AL1-8	Presser foot with moving guide(1/8,left)	15	2	3.2	8	4.8
21	JSH-001AL3-16	Presser foot with moving guide(3/16,left)	16	2	4.8	8	4.8

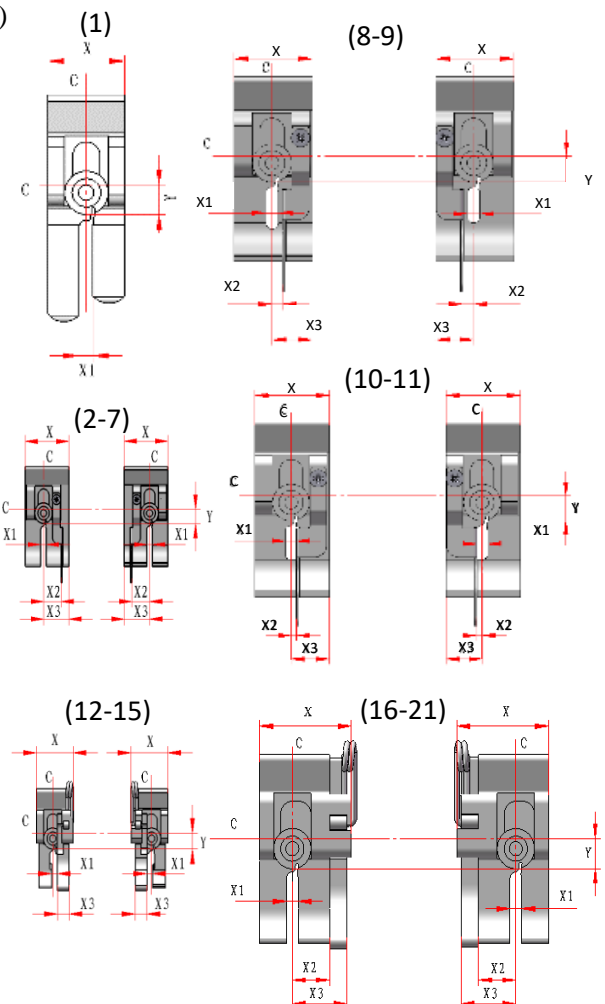

2-11-1, TSURUMAKI, TAMA-SHI,  
TOKYO 206-8551, JAPAN  
PHONE : (81) 42-357-2360  
FAX : (81) 42-357-2380  
<http://www.juki.com>



\*Specifications and appearance are subject to change without prior notice for