

# WOLF® 'ZA' RAG CUTTER PARTS AND SERVICE MANUAL

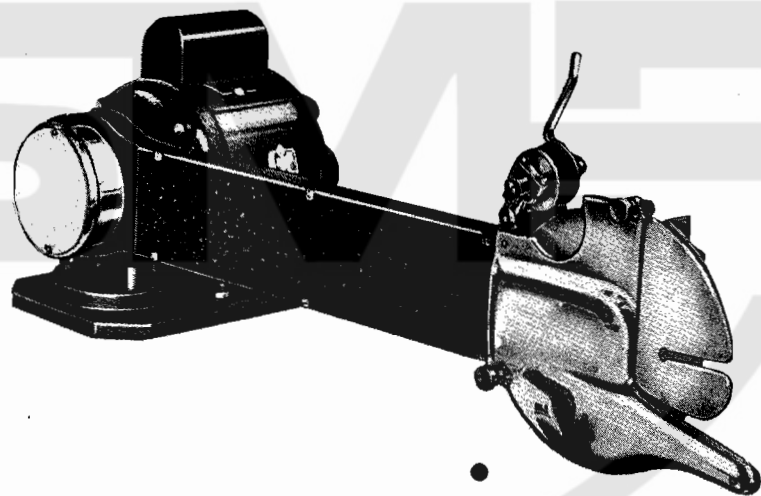

- **DOUBLE ARM  
PORTABLE  
MODEL**



- **SINGLE ARM  
TABLE MODEL**

## **WARNING**

ALWAYS EXERCISE CARE WHEN HANDLING OR USING THIS MACHINE. Disconnect electrical connector before performing repairs, adjustments or maintenance. Be sure machine is properly grounded. When handling or replacing blades exercise care to prevent bodily harm.

**WOLF**®  
*1st/Since 1888*

### **THE WOLF MACHINE COMPANY**

5570 Creek Road, Cincinnati, Ohio 45242 / U.S.A.  
PHONE: 513-791-5194 / Telex 214308 WEPCO  
TOLL FREE 1-800-543-WOLF / Telex Int. 6842069

# ZA RAG CUTTER

## Part Drawings & Numbers

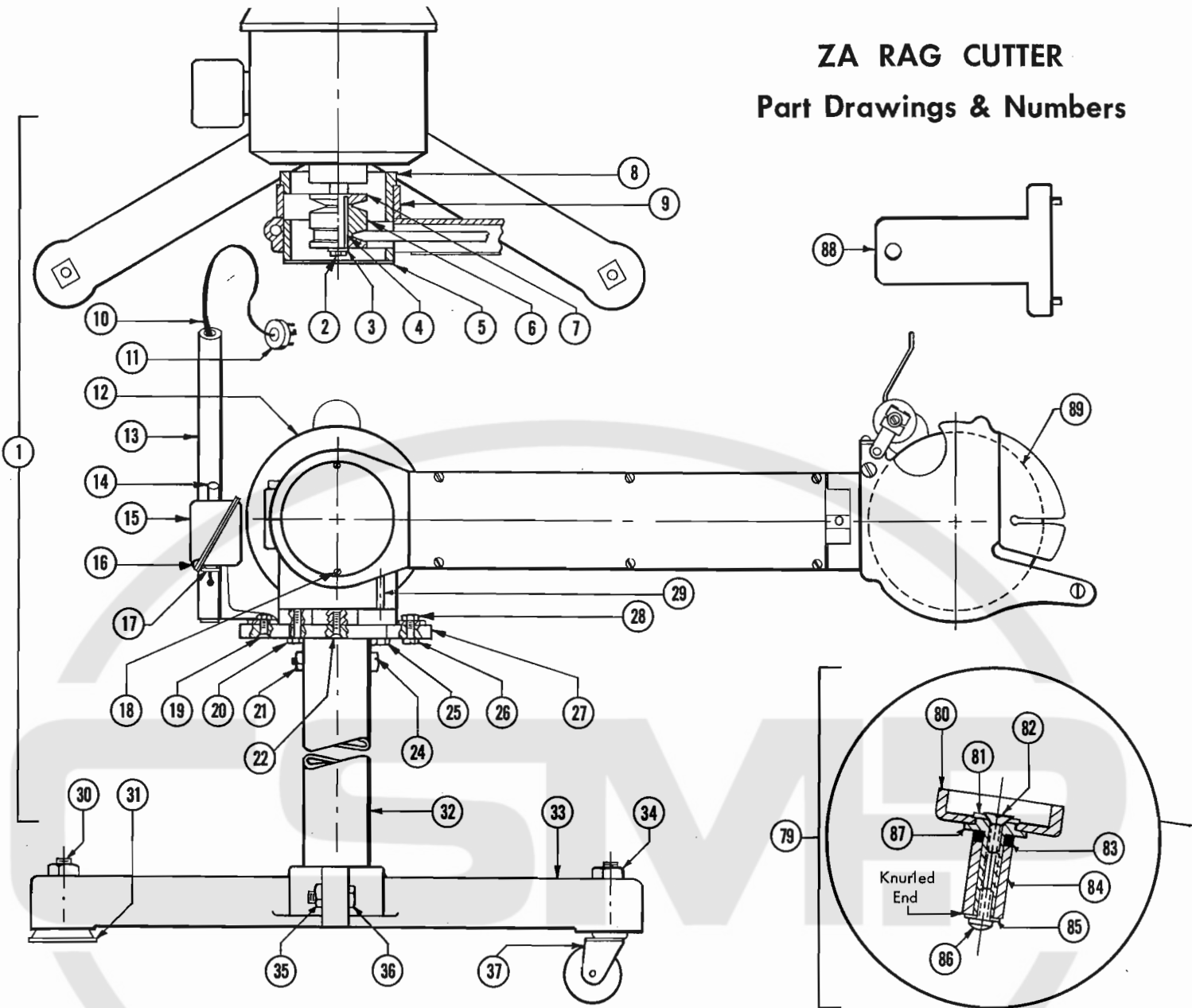

Ref. No.	Description	Quantity used if more than 1	Prime No.
1	Rag Cutter Complete Assembly		1500050
2	Screw 1/4 - 28 x 3/4 Hex Hd.		9901492
3	Pulley Washer		1500700
4	Key		1500400
5	Cover		1502100
6	Center Section Pulley		1500900
7	V-Belt Pulley	2	1500800
8	Rag Cutter Arm Bracket		1501600
9	Collar (Single Head Model Only)		1507800
10	Wire		
	18-4-300 V. Wire (3 Phase)		1117393
	18-3-300 V. Wire (1 Phase)		1117193
11	Hubble Plug		
	3 Phase		1106200
	1 Phase		1107600
12	Motor Complete		
	230/460 - 3 Ph. - 60 cy.		1500300
	110/220 - 1 Ph. - 50 cy.		1500200
	110/220 - 1 Ph. - 60 cy.		1500100
13	Pipe Ext. Line Wire (Optional)		1512560
14	Switch		1809193
15	Switch Cover		1512700
16	Screw #4 - 36 x 1/4 RHMS	2	9900032
17	1/2" Romex Conn.		1113293

Ref. No.	Description	Quantity used if more than 1	Prime No.
18	Screw #6 - 32 x 3/8 RH Thread Cut	2	9901560
19	Screw 5/16 - 18 x 1 Flt. Hd. (Table Model)	4	9900469
20	Screw 1/4 - 28 x 3/4 Hex Hd.	3	9901492
21	Nut 3/8 - 16 Sq. Hd.		9901662
22	Screw 1/4 - 28 x 3/4 Flt. Hd. (Table Model)	3	9900696
24	Bolt 3/8 - 16 x 3 Sq. Hd.		1504393
25	Nut 3/8 - 24 Hex Hd.		9901708
26	Bolt 5/16 - 18 x 1 Sq. Hd.	4	1500293
27	Motor Base (Table Model)		1506400
27	Motor Base		1506300
28	Nut 5/16 - 18 Hex Hd.	4	9901679
29	Stop Stud		1501700
30	Bolt	3	1506593
31	Rubber Foot	3	1506700
32	Standard Column		1502200
33	Standard Foot	3	1506600
34	Nut 1/2 - 13 Sq. Hd.	3	9901664
35	Nut 3/8 - 16 Sq. Hd.	3	9901662
36	Bolt 3/8 - 16 x 1-1/2 Sq. Hd.	3	1504593
37	Castor Assy. - Optional	3	1512660
38	Cutter Head & Arm Comp.	1 or 2	1513550
39	Screw 3/8 - 24 x 2 Soc. Hd. Cap		9901191
40	Cutter Arm		1501800

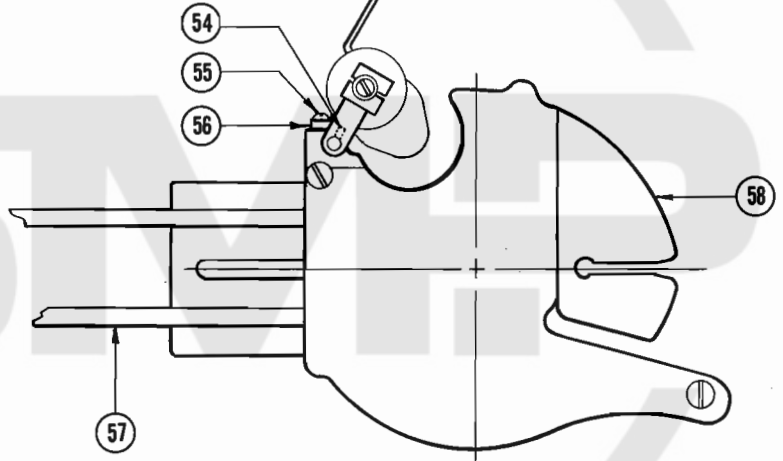
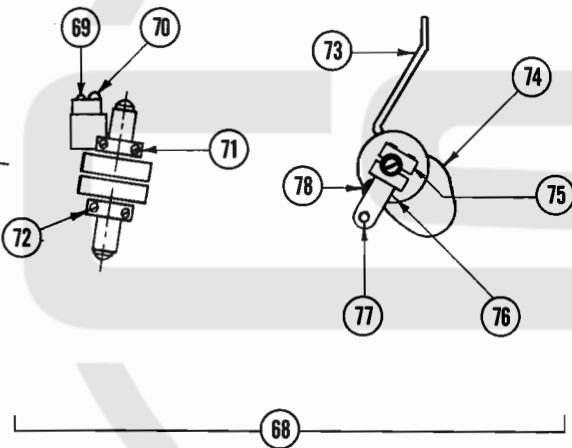
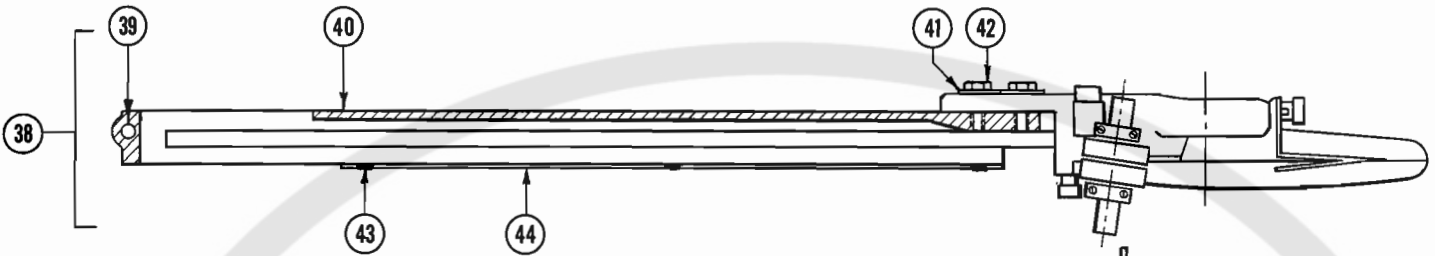
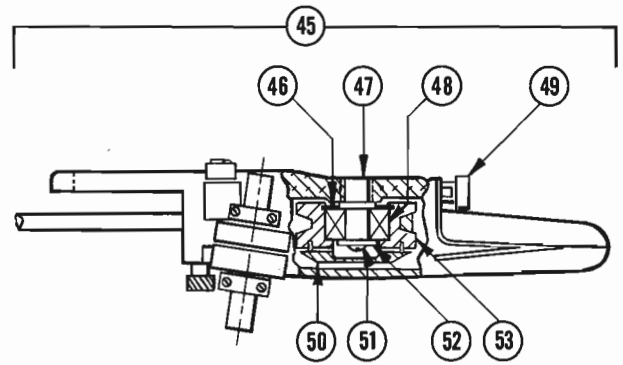
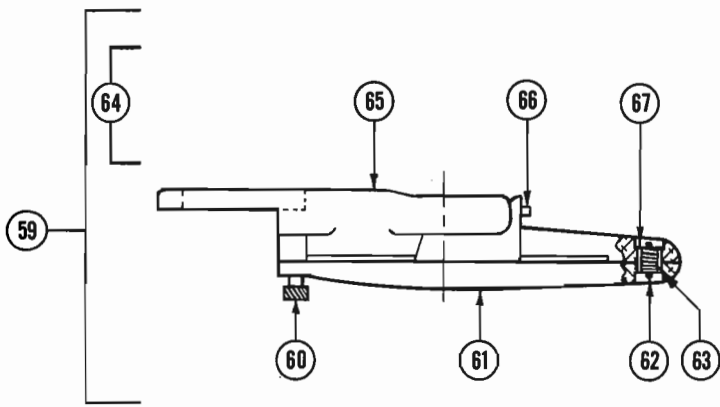

Ref. No.	Description	Quantity used if more than 1	Prime No.
41	Flat Washer 3/8 Dia.	2	9901988
42	Screw 3/8 - 16 x 1 Hex Hd.	2	9901442
43	Screw #8 - 32 x 1/4	6	9900119
44	Cutter Arm Cover		1502000
45	Cutter Head W/Belt S.A. (45 thru 87)		1513551
46	Ret. Ring #5100 - 125		1502600
47	Knife Pulley Stud		1503100
48	Bearing		1503093
49	Thumb Nut Assy.		1200760
50	Knife Nut		1506100
51	Cap Screw #10 - 32 x 1/2 R.H.		9900165
52	Retaining Washer		1505600
53	Knife Pulley & Pins		1505800
54	Set Screw #8 - 32 x 3/16		9901846
55	Screw #8 - 32 x 3/8 RHMS		9900121
56	Grinder Stop		1505200
57	Belt		1506293
58	Button Cutter		1501260
59	Head & Cover S. A. (60 thru 67)		1502460
60	Thumb Nut Assy.		1200760
61	Cover		1501100
62	Roll Pin 5/64 Dia. x 7/16	2	9902014
63	Tension Spring		1507500
64	Head W/Bushing & Pin (65 thru 67)		1502461

Ref. No.	Description	Quantity used if more than 1	Prime No.
65	Head		1502400
66	Pin		9902042
67	Pivot Bushing		1507400
68	Grinder Complete (69 thru 87)		1505050
69	Grinder Spring		4580000
70	Screw #6-32 x 1/2 Thred Cut RHMS		9901561
71	Screw #8-32 x 3/4 Fil. Hd. Cap	2	9900573
72	Screw #8-32 x 5/8 Fil. Hd. Cap	2	9900572
73	Grinder Handle		1505500
74	Shield		1507700
75	Grinder Frame Cap	2	4577300
76	Grinder Frame		1503300
77	Rocker Shaft		1504800
78	Screw #4-36 x 1/4 RHMS	3	9900032
79	Emery Shaft Comp. S. A. (80 thru 86)	2	4548050
80	Emery Wheel - 150		4548300
81	Emery Wheel Washer		4548593
82	Screw #6 - 32 x 5/16		9900338
83	Fiber Washer		4548693
84	Grinder Journal	2	4548800
85	Washer #10 Burr		9902319
86	Cap Scr. #6 - 32 x 3/8 Binder Hd.		9902256
87	Emery Wheel Shaft		4548700
88	Pin Wrench to remove Knife Nut		1506960
89	Blade - Carbon		1426970
	Blade - Teflon		1426971

# SERVICE AND MAINTENANCE

Keep the machine clean and properly adjusted, as this will add to its life and efficiency.

## **CAUTION:**

### **Correct Rotation**

Correct rotation of knife blade is clockwise when viewed from knife retaining nut side of blade. Single phase motors are wired at factory with correct rotation. Should three phase motor rotate in wrong direction, reverse direction of rotation by interchanging connections of any two power leads inside of junction box on side of motor.

### **Lubricating**

All bearings of machine are lubricated for life and require no attention.

### **Sharpening Knife**

It is most essential that a keen cutting edge be kept on the knife at all times, as this insures clean and easy cutting. To obtain this, the grinding wheels must be kept properly adjusted. Because of the wear of knife and emery wheels, it is necessary to adjust emeries toward the knife to avoid long bevel. Wheels must touch knife evenly. Adjustment is made by releasing screws clamping the threaded journals. The journals can then be turned to the proper position. Care should be taken that the emery wheels do not go too far down on knife. A good bevel of 1/8" makes a good cutting edge. Emeries must spin free at all times.

To oil journals, remove screw in end of bushing shaft and oil. Keep emery free from oil and grease. To do this, remove emery and rub wheels together until they show a good surface.

### **To Remove Knife**

Remove thumb screw (Ref. #49) and button guard (Ref. #58). Loosen knurled thumb screw (Ref. #60) and rotate safety cover (Ref. #61) from over knife. Insert 1/8 diameter pin through hole in rear head housing. Rotate knife blade (Ref. #89) until pin enters mating hole in back of knife pulley. Using special pin wrench (Ref. #88), rotate knife retaining nut (Ref. #50) clockwise to release knife. **CAUTION** - Knife is sharp - protect your fingers. Reverse procedure to install new blade making certain that new blade seats correctly over blade driving pins.

### **Replacing or Adjusting Driving Belts**

To adjust belt tension, loosen (2) hex head bolts (Ref. #42) and pull cutter head assembly away from motor until belts are tight. To avoid excessive bearing wear, do not tighten belt excessively. Re-tighten 2 hex head bolts. To replace belt, remove knife blade, remove cutter arm cover (Ref. #44) and motor pulley cover (Ref. #5). Loosen 2 hex head bolts (Ref. #42) and slide cutter head assembly as far as possible towards motor. Remove old belts and install new ones. Replace all covers and re-tighten belt.

**WOLF**  
®  
*1st/Since 1888*

### **THE WOLF MACHINE COMPANY**

5570 Creek Road, Cincinnati, Ohio 45242 / U.S.A.

Phone: Area Code 513 791-5194 / Telex #214308 WEPCO