



Union Special
INDUSTRIAL SEWING EQUIPMENT

2-3 NEEDLE FLAT BED COVERSEAM MACHINE

FS300 SERIES

2-3 NEEDLE CYLINDER BED COVERSEAM MACHINE

CS100 SERIES

ENGINEER'S MANUAL

EN9424

PREFACE

This Engineer's Manual is written for the technical personnel who are responsible for the service and maintenance of the machine.

This manual describes "Standard Adjustment", "Adjustment Procedures", "Results of Improper Adjustment", and other important information which are not covered by the Instruction Manual.

It is advisable to use the relevant Instruction Manual and Parts List together with this Engineer's Manual when carrying out the maintenance of these machines.

This manual gives the "Standard adjustment" on the former page under which the most basic adjustment value and on the latter page the "Results of improper adjustment" under which errors and troubles arise.



CONTENTS

1. SPECIFICATIONS	4
2. MOTOR PULLEY AND BELT	5
3. MODEL NUMBERING SYSTEM	6
4. STANDARD ADJUSTMENT	10
(1) FS300	10
1) NEEDLE FEED TIMING	10
2) ADJUSTING THE TIMING RELATION BETWEEN THE NEEDLE BAR AND LOOPER (SYNCHRONIZATION)	10
2) SYNCHRONIZATION	12
3) RETURNING AMOUNT OF THE LOOPER	14
4) HEIGHT OF THE NEEDLE BAR	14
5) CLEARANCE BETWEEN THE LOOPER AND NEEDLE	16
6) ADJUSTING AMOUNT OF THE LOOPER-AVOID	16
7) POSITION OF THE NEEDLE GUARD	16
8) POSITION OF THE FEED DOG	18
9) SPREADER	20
10) LOOPER THREAD CAM	22
11) POSITION OF THE PRESSER BAR	22
12) POSITION OF THE NEEDLE THREAD TENSION RELEASE (WITHOUT THREAD TRIMMER)	24
13) POSITION AND HEIGHT OF THE PRESSER FOOT	24
14) POSITION OF THE THREAD GUIDE	24
(2) CS100	28
1) NEEDLE FEED TIMING	28
2) ADJUSTING THE TIMING OF THE NEEDLE BAR AND LOOPER (SYNCHRONIZATION)	28
2) SYNCHRONIZING LOOPER AND NEEDLE MOTIONS	30
3) RETURNING AMOUNT OF THE LOOPER	32
4) HEIGHT OF THE NEEDLE BAR	34
5) POSITION OF THE NEEDLE GUARD	34
6) CLEARANCE BETWEEN THE LOOPER AND NEEDLE	36
7) ADJUSTING AMOUNT OF THE LOOPER-AVOID	36
8) POSITION OF THE FEED DOG	38
9) SPREADER	40
10) LOOPER THREAD CAM	42
11) LOOPER THREAD WRAP-UP PREVENTING CAM	42
12) POSITION OF THE PRESSER BAR	44
13) POSITION OF THE NEEDLE THREAD TENSION RELEASE (WITHOUT THREAD TRIMMER)	44
14) POSITION AND HEIGHT OF THE PRESSER FOOT	44
15) POSITION OF THE THREAD GUIDE	46
4. OTHER PRECAUTIONS	47
(1) POINTS TO WHICH LOCKTITE IS APPLIED	47
5. TROUBLES AND CORRECTIVE MEASURES	49

1. SPECIFICATIONS

FS300 Series

	FS322	FS322	FS332	FS332
Sewing speed *	With Puller 6000 R.P.M. 6,500 S.P.M. (Max) left or right hand undertrimmer 5500			
Stitch length	1.6 to 2.8 mm			
No. of needle	2	3	2	3
Needle gauge	3.2, 4.0	5.6, 6.4, 4.8	3.2, 4.0	4.8, 5.6, 6.4
Top covering	Without		With	
Diff. feed ratio	Gathering stitch 1:1.5		Stretching stitch 1:0.6	
Needle	UY128GBS #65/025 to 90/036			
Presserfoot lift	8.0 mm			
Lubricating oil	UNION SPECIAL Designated oil (Part No. 28604R)			

CS100 Series

	CS122	CS122	CS132	CS132
Sewing speed *	With Puller 6000 R.P.M. 6,500 S.P.M. (Max) Undertrimmer 5500 R.P.M.			
Stitch length	1.6 to 3.2 mm			
No. of needle	2	3	2	3
Needle gauge	3.2, 4.0, 4.8	5.6, 6.4	3.2, 4.0, 4.8	5.6, 6.4
Top covering	Without		With	
Diff. feed ratio	Gathering stitch 1:1.5		Stretching stitch 1:0.6	
Needle	UY121GJS #55/022 to #90/036			
Presserfoot lift	8.0 mm			
Lubricating oil	UNION SPECIAL Designated oil (Part No. 28604R)			

* Depending on Devices

2. MOTOR PULLEY AND BELT

FS300 Series

Sewing speed (s.p.m.)	50 Hz			60 Hz		
	Motor pulley	V belt (inch)		Motor pulley	V belt (inch)	
	outer dia. (mm)	Fully-submerged type	Semi-submerged type	outer dia. (mm)	Fully-submerged type	Semi-submerged type
6,500	140	35		120	35	
6,000	125	35		105	35	
5,500	110	35		90	34	
5,000	100	34		85	34	
4,500	90	34		75	34	
4,000	80	34		70	34	
3,500	70	34		60	33	

- 1) Use a UNION SPECIAL clutch motor (400W).
- 2) Use an M type V belt.
- 3) The table shows the sewing speeds obtained by the use of motor pulleys with different diameters and V belts with different lengths.
- 4) Note that the effective diameter of the pulley of the machine head is 54mm

CS100 Series

Sewing speed (s.p.m.)	50 Hz			60 Hz		
	Motor pulley	V belt (inch)		Motor pulley	V belt (inch)	
	outer dia. (mm)	Fully-submerged type	Semi-submerged type	outer dia. (mm)	Fully-submerged type	Semi-submerged type
6,500	145	43	40	120	41	38
6,000	135	43	40	110	41	38
5,500	120	41	38	100	41	38
5,000	110	41	38	90	39	37
4,500	95	41	38	80	39	37
4,000	85	39	37	70	39	37
3,500	75	39	37	60	38	35

- 1) Use a UNION SPECIAL clutch motor (400W).
- 2) Use an M type V belt.
- 3) The table shows the sewing speeds obtained by the use of motor pulleys with different diameters and V belts with different lengths.
- 4) Note that the effective diameter of the pulley of the machine head is 57.5 mm.

3. MODEL NUMBERING SYSTEM

CS100 SERIES ORDERING INFORMATION

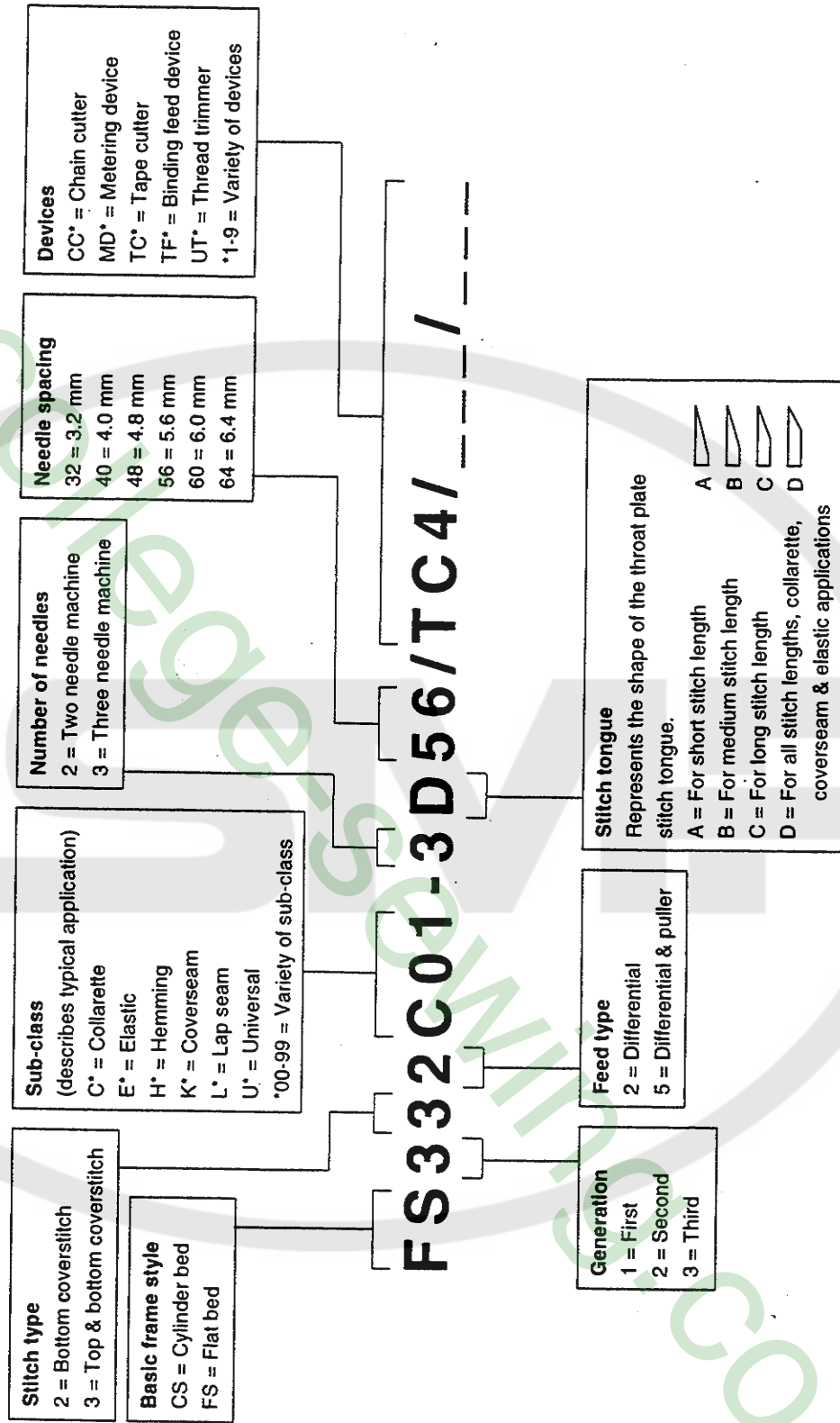

CS100 SERIES ORDERING INFORMATION

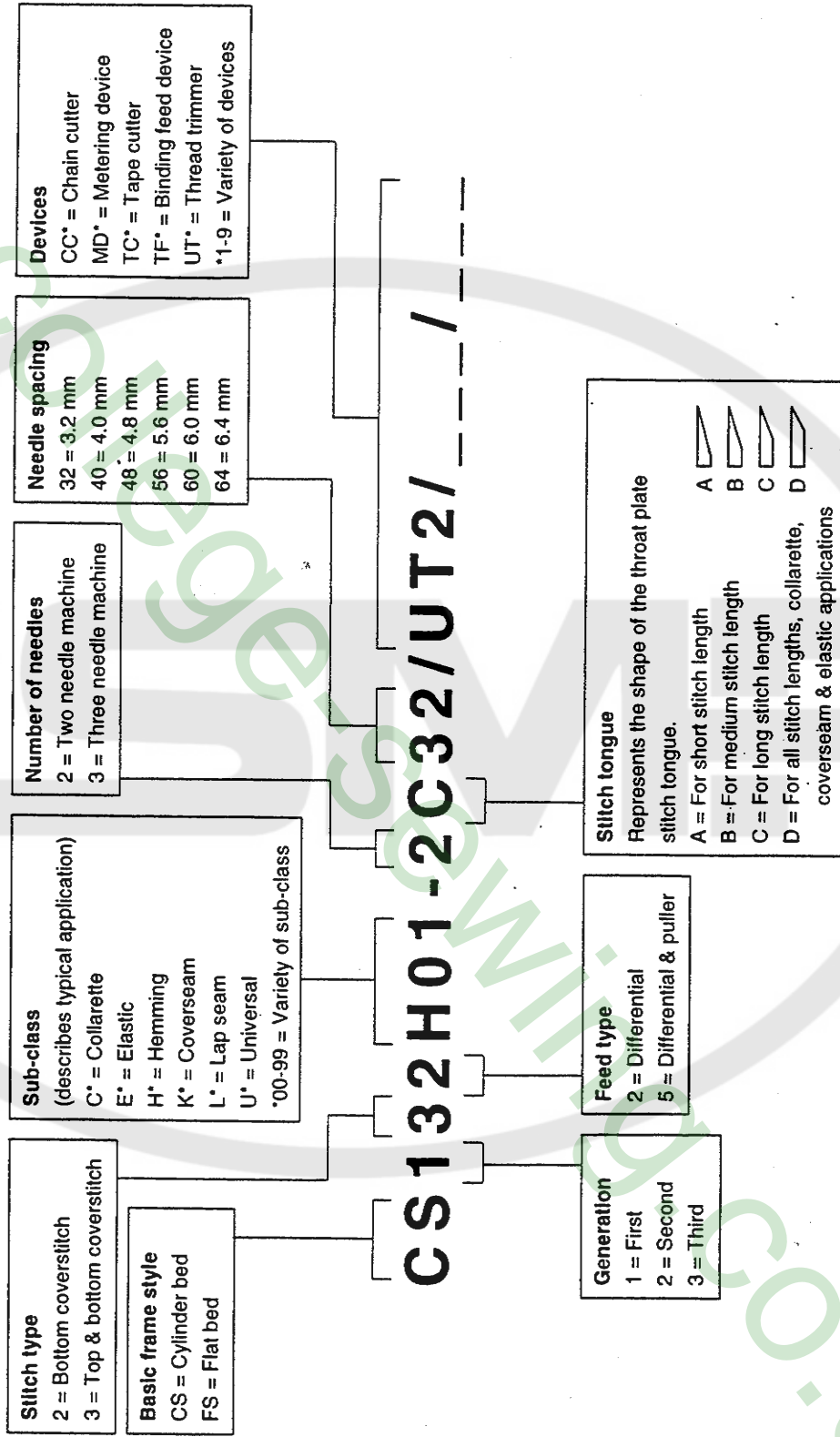

FS300 Series

Code	Specification	Description of Sub-Class
C01	For Collarete	Basic style
E12	For elastic tape attaching	Right hand fabric under trimmer and metering device (Upper side)
E41	For elastic tape attaching	Elastic tape attaching with puller and metering device (Lower side) (with endless rubber)
H01	For hemming	Basic style with hem guide
L01	For lap seam	Basic style
L21	For lap seam	For the top sleeve of knit fabric

CS100 Series

Code	Specification	Description of Sub-Class
E11	For Elastic tape attaching	Right hand fabric under trimmer, (Preclosed Elastic)
E12	For elastic tape attaching	Fabric under trimmer, and metering device (Upper side)
H01	For Hemming	Basic style with hem guide
H11	For Hemming	With cloth puller
H21	For Hemming	Left hand fabric under trimmer
K01	Covering	With standard fixed seam guide, light weight fabric
K02	Covering	With adjustable seam guide for medium to heavy-weight fabrics
K11	Coverseaming	With special fold over seam guide

Under-bed thread trimming device

Code	For use on model	Electromagnetic type				Pneumatic type				
		Thread trimmer	Needle thread wiper	Top covering thread trimmer	Auto-lifter	Thread trimmer	Needle thread wiper (Mechanical)	Needle thread wiper (Pneumatic)	Top covering thread trimmer	Auto-lifter
UT1	CS122	○	○		○					
UT2	CS132	○		○	○					
UT3	CS122					○	○			○
UT4	CS122					○		○		○
UT5	CS132					○			○	○
UT10	FS322	○	○		○					
UT11	FS332	○		○	○					
UT12	FS322					○	○			
UT13	FS332					○			○	○

Elastic tape metering device

Code	Description		For use on model
MD1	Metering device (upper side)	Electric single stage	FS322, FS332, CS122, CS132
MD2	Metering device (upper side)	Electric two stage	FS322, FS332, CS122, CS132
MD3	Metering device (lower side)	Electric single stage	FS322, FS332, CS122, CS132
MD4	Metering device (lower side)	Electric two stage	FS322, FS332, CS122, CS132

Automatic tape feeding device

Code	Description	For use on model
TF1	Automatic tape feeding device (upper side)	For MD1, MD2
TF2	Automatic tape feeding device (lower side)	For MD3, MD4

Under-bed thread trimming device

Code	Description		For use on model
CC1	Pneumatic type chain-off thread cutter	Mounted horizontal venturi suction	FS322, FS332

Cloth puller

Code	Description	For use on model
PL1	Cloth puller	FS322, FS332, CS122, CS132

4. STANDARD ADJUSTMENT

(1) FS300

Standard Adjustment

1) Needle feed timing

First screw (A) in operating direction on double eccentric (B) of feed drive assembly must be straight up, when the needle bar is at bottom of stroke.

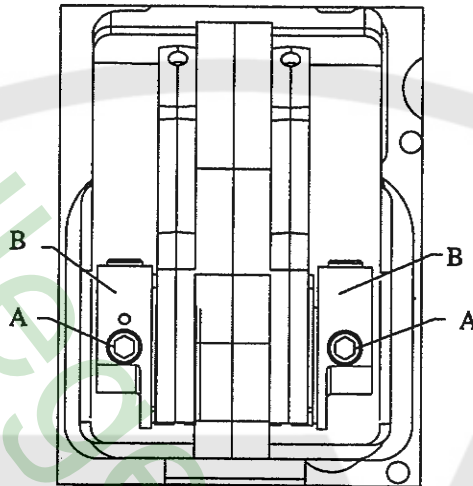

2) Adjusting the timing relation between the needle bar and looper (synchronization): Without gauges

When the blade point of the looper moves to the left in the rear of the needle and to the right in front of the needle, align the upper end of the eyelet of the left needle with the lower face of the looper so that the distance between A and B, the side of the left needle to the blade point of the looper, should be equal.

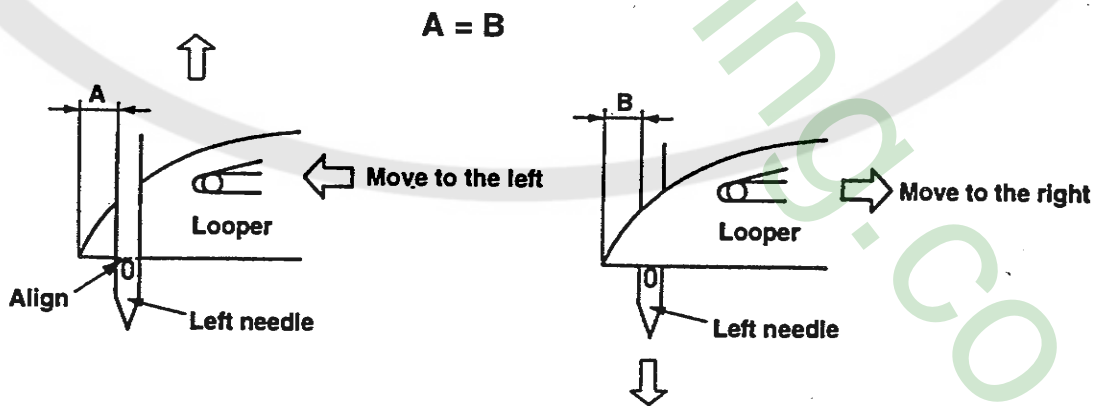

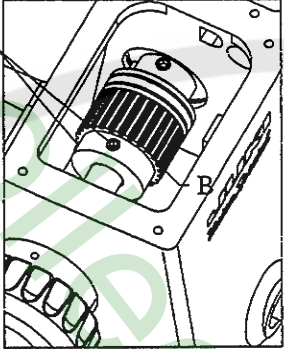
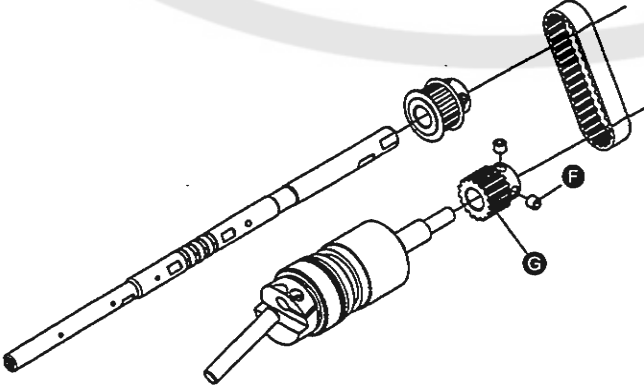
Adjustment Procedures	Results of Improper Adjustment
<ul style="list-style-type: none"> • Remove top cover, oil reservoir cover, gasket and cloth plate. • Loosen screws (C) of sprocket (D). • Rotate lower main shaft in operating direction clockwise, until the first screw (A) on double eccentric (B) is straight up. • Holding pulley to prevent it from turning, rotate handwheel of upper main shaft until needles are at top of their stroke. • Torque screw (C) to 45–46 in. lbs. (5.2–5.4Nm). • Replace top cover, oil reservoir cover, gasket and cloth plate.  <p>Note: Earlier machines have (4) screws.</p>	<ul style="list-style-type: none"> • Needle breakage • Loper missing needle thread
<ul style="list-style-type: none"> • Turn handwheel in operating direction until bottom of looper is even with top of needle eye. Note dimension (A) • Continue turning handwheel in operating direction until bottom of looper is even with top of needle eye when looper is in front of needle. Note dimension (B) • If (A) is greater than (B) <ul style="list-style-type: none"> –Loosen (C) on sprocket (D). –Turn sprocket (D) in operating direction –Tighten screws (C) –Repeat above two steps until (A) = (B) • If (A) less than (B) <ul style="list-style-type: none"> –Loosen screws (C) on sprocket (D) –Turn sprocket (D) in reverse direction –Tighten screws (C) –Repeat above two steps until (A) = (B) 	<ul style="list-style-type: none"> • If the timing is not correct, skip stitching may occur.

Standard Adjustment

2) Synchronization

- Rotate handwheel in operating direction until pin in looper holder contacts gauge plate.
- Reposition needle bar as required to set pointer of indicator gauge at "0".
- Rotate handwheel in reverse direction until pin in looper holder again makes contact with gauge plate.
- A variation of (1) graduation on scale is permissible.

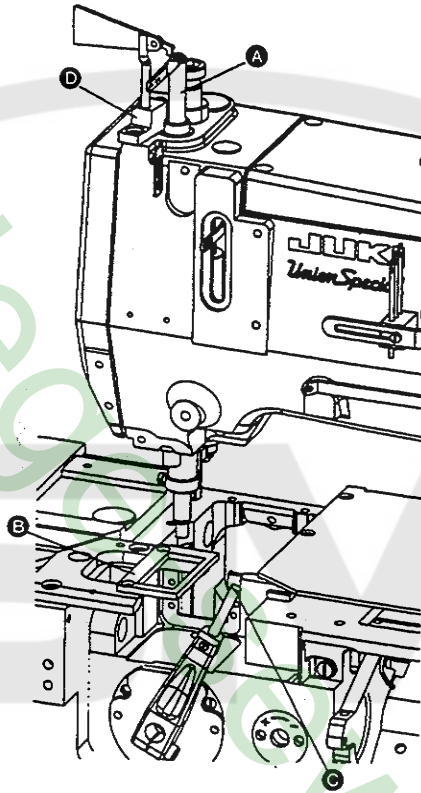

Adjustment Procedures

- Rotate handwheel in operating direction until pin **C** contacts gauge plate **B**.
- Loosen screw **D** in needle bar connection & position needle bar **E** as required to set pointer **I** of indicator gauge **H** at "0" tighten screw **D** lightly.
- Rotate handwheel in reverse direction until pin **C** makes contact with gauge plate **B**.
Note reading on gauge. A variation of (1) graduation on scale is permissible.

To adjust:

- Loosen screws **F** on looper drive sprocket **G**.
- If reading is above "0" turn sprocket towards operator.
- If reading is below "0" turn sprocket away from operator.
- snug screws **F**.
- Continue to check & adjust in both operating & reverse directions until pointer **I** of indicator gauge **H** comes within (1) graduation on scale when turning handwheel in either direction.
- Tighten screws **F**.
- Torque needle bar screw **D** to 20 in/lbs.

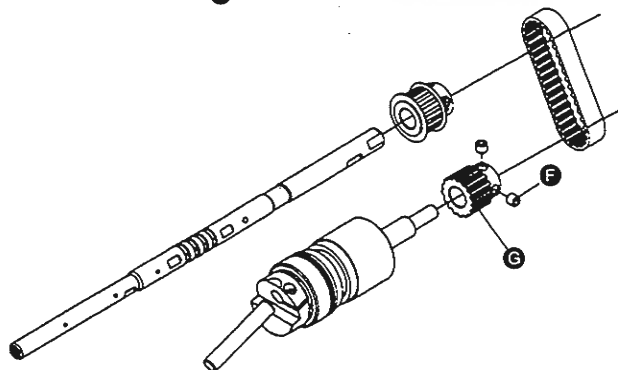
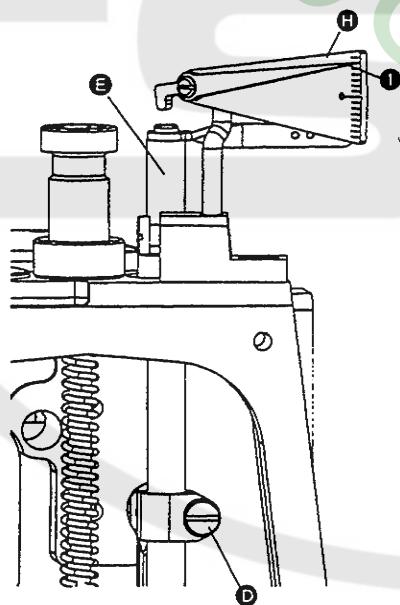

Results of Improper Adjustment

- Skipped stitches
- Improper chaining

Standard Adjustment

3) Returning amount of the looper

When the looper is in the extreme right position, the distance between the blade point of the looper and the center of the right needle is 4.4 ± 0.1 mm.

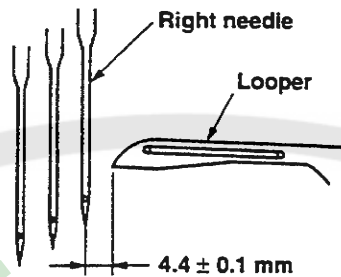
**4) Height of the needle bar**

When the looper moves to the left and the blade point of the looper comes out from the left side of the left needle by 0.7 to 1.0 mm, the lower face of the looper aligns with the upper end of the eyelet of the left needle.

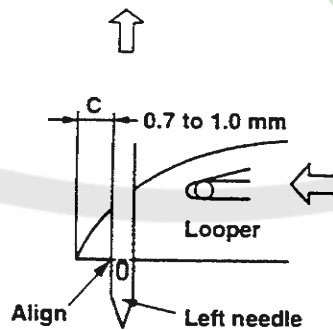

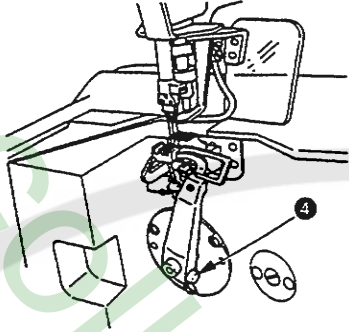
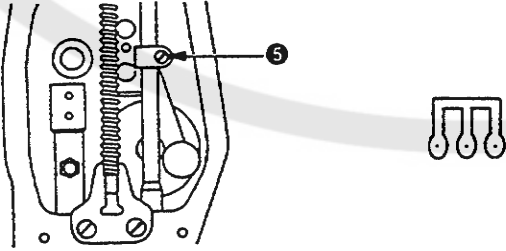
Adjustment Procedures	Results of Improper Adjustment
<ul style="list-style-type: none"> ○ Loosen the looper base setscrew ④ and adjust the returning amount of the looper. (Use a 5/32 inch hexagonal wrench.) 	<ul style="list-style-type: none"> ○ If the returning amount is large, skipping stitch and tangling stitch may occur and the range of the thickness of the cloth to be sewn is reduced. ○ If the returning amount is small, skipping stitch and tangling stitch may occur.
<ul style="list-style-type: none"> ○ Loosen the needle bar holder screw ⑤ and adjust the height of the needle bar. (Caution) After the adjustment, check that the direction of the needle clamp is correct and the respective needles enter the center of the holes of the throat plate. 	<ul style="list-style-type: none"> ○ If the distance of C is large, skip stitching and tangling stitch may occur. ○ If the distance of C is small, skip stitching and tangling stitch may occur. ○ If defective stitch occurs with the woolly nylon thread, make the distance C as small as possible.

Standard Adjustment

5) Clearance between the looper and needle

Clearance between the blade point of the looper and the grooves of the right/left needles is 0 to 0.05 mm. (Clearance of the middle needle becomes larger a little.)

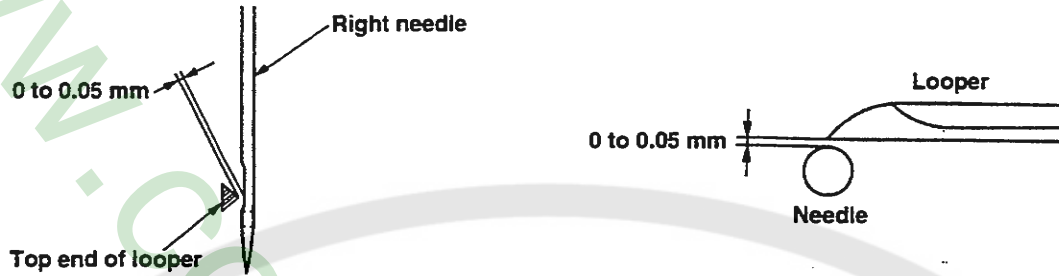

6) Adjusting amount of the looper-avoid

When the needle descends, the top point of the needle touches the back of the looper at the position of 2/3 from the upper side of the looper.

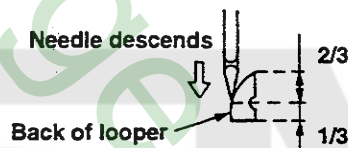

7) Position of the needle guard

① Rear needle guard

- The height of the rear needle guard is in the position that the rear needle guard is 1.2 mm above the top of the needle when the looper moves to the left as shown in the figure.
- The longitudinal position and inclination of the rear needle guard are in the position that when the right side of the respective needles comes to the blade top of the looper, the top of the needle slightly touches the rear needle guard.

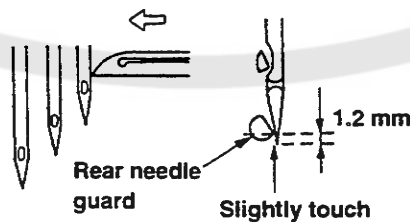

② Moving needle guard

- When the looper advances, the clearance between the needle and the moving needle guard is 0.05 to 0.13 mm.

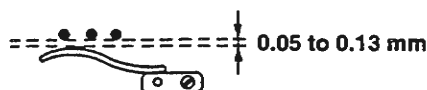

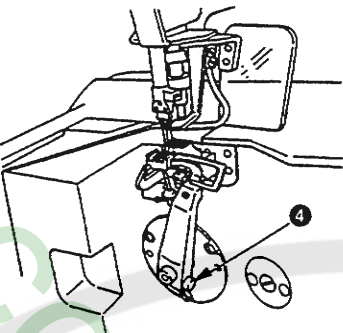
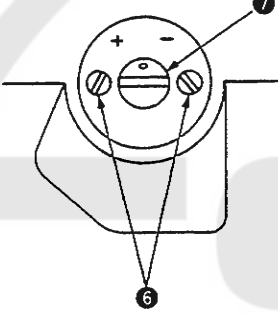
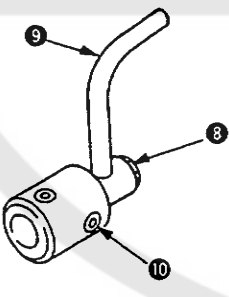
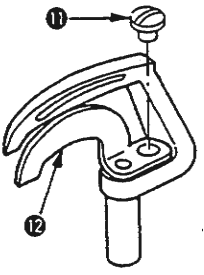
Adjustment Procedures	Results of Improper Adjustment
<p>○ Loosen the looper base setscrew ④ and adjust by moving the looper base back and forth.</p> 	<ul style="list-style-type: none"> ○ If the clearance is too large, the loop of the needle thread is not scooped and the back of the looper hits strongly the top point of the needle which causes the damage of the needle point. ○ If the clearance is too small, skipping stitch will occur due to the damage of the tip of the looper, the needle breakage, and the large clearance between the back of the looper and the needle.
 <ul style="list-style-type: none"> ○ Loosen the two screws ⑥ and adjust by rotating the eccentric pin ⑦. ○ Amount of the avoid increases in the direction of +. ○ Amount of the avoid reduces in the direction of -. <p>(Caution) After the adjustment, check again the clearance between the blade point and the groove of the needle.</p>	<ul style="list-style-type: none"> ○ If the amount of the avoid is large, the clearance of the back of the looper and the needle becomes large, and skipping stitch and tangling stitch will occur. ○ If the amount of the avoid is small, the needle hits strongly the back of the looper. This causes the damage of the needle point, the needle breakage and the damage on the back of the looper.
 <ul style="list-style-type: none"> ○ Loosen the screw ⑧ and adjust the height and inclination of the rear needle guard ⑨. Loosen the screw ⑩ and adjust the longitudinal position of the rear needle guard ⑨. <p>(Caution) Check that the rear needle guard does not break the loop of the needle thread by touching the groove of the needle.</p>  <ul style="list-style-type: none"> ○ Loosen the screw ⑪ and adjust the clearance between the moving needle guard ⑫ and the needle. <p>(Caution) Check that the needle is never caught between the moving needle guard and rear needle guard in any case.</p>	<ul style="list-style-type: none"> ○ If the returning amount is large, skipping stitch and tangling stitch occur, and the range of the thickness of the cloth to be sewn is reduced. ○ If the returning amount is small, skipping stitch and tangling stitch occur.

Standard Adjustment

8) Position of the feed dog

- The clearance of the left/right sides of the feed dog should be equal in the slots of the throat plate.
- At the maximum travel, the clearance of the main feed dog and differential feed dog is equal to $A = A'$, $B = B'$.
- The height of the feed dog is 1.0 mm at the top of their stroke.
- The tilt of the feed dog is parallel to the throat plate when the needle bar is at the highest position.

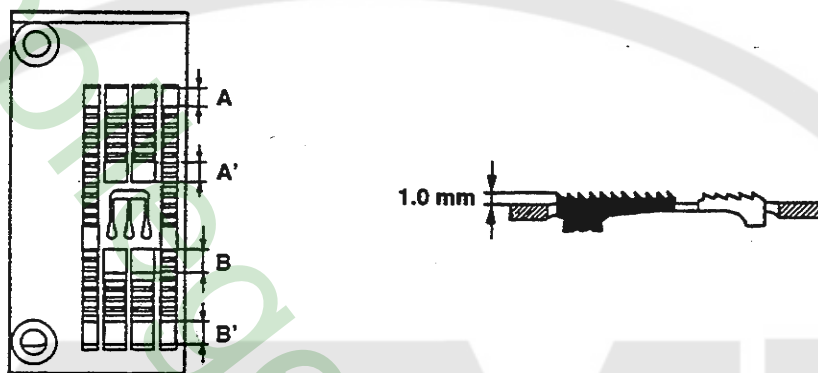

Adjustment Procedures

Open the cover located at the rear side of the needle entry.

- Adjust the longitudinal position of the main feed dog after loosening the nut 13 and rotating the eccentric nut 14.
- Adjust the longitudinal position of the differential feed dog after loosening the nut 15 and rotating the eccentric nut 16.

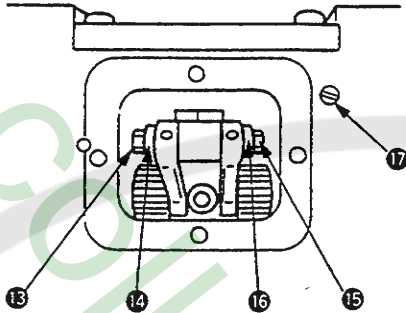

- Adjust the inclination of the feed dog after loosening the screw 17 and rotating the eccentric shaft inside with a slit-screwdriver through the hole 18.

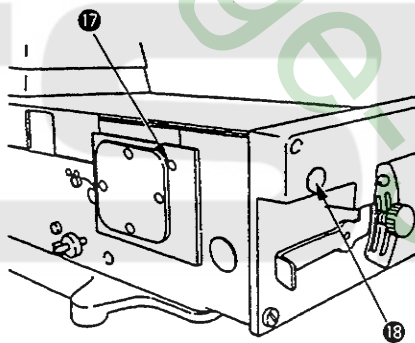

- Loosen the screw 19 and adjust the height of the main feed dog 20.
- Loosen the screw 21 and adjust the height of the differential feed dog 22.

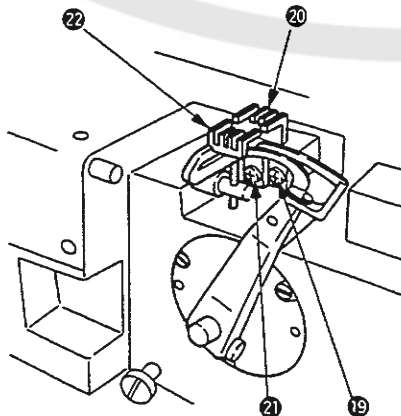

Results of Improper Adjustment

- If the left/right positions of the feed dog are incorrect, the left/right sides and the throat plate will wear out.
- Heating and abnormal noise will be produced.
- The feed components will wear out early. And, the looseness, bending and abnormal noise will be produced.

- If the inclination of the feed dog is raised toward you, starting of the workpiece will be affected.
- If the inclination of the feed dog is lowered toward you, it may cause the irregular stitching and puckering.

- If the position of the feed dog is high, it causes the return feed, skip stitching and defective chain-off.
- If the main feed dog, differential feed dog and throat plate come in contact each other, it will cause the breakage.
- If the position of the feed dog is low, the stitch length becomes short when the sewing is finished.

Standard Adjustment

9) Spreader

① Timing

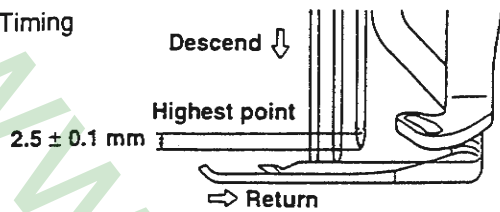

Just when the needle descends 2.5 mm from the highest point of the needle bar, the spreader begins to return from its extreme left position.

② Stroke

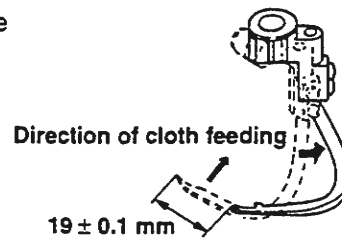

③ Position of spreader

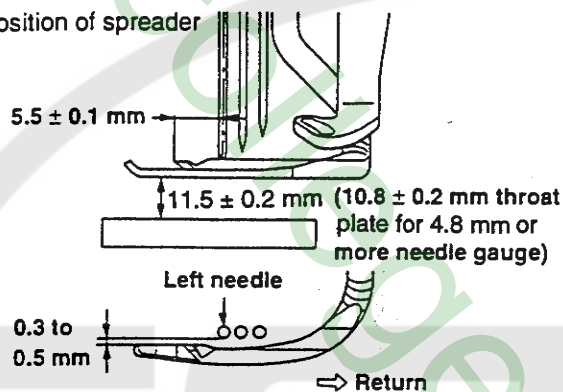

- The height is 11.5 ± 0.2 mm ($4.0 + 3.2$ gauge). (10.8 ± 0.2 mm for 4.8 mm, 5.6 mm, and 6.4 mm gauges).
- When the spreader is in the extreme left position, the distance between the center of the left needle and the top blade of the spreader is 5.5 ± 0.1 mm.
- When the spreader returns to the right, the clearance between the spreader and the left needle is 0.3 to 0.5 mm.

④ Fixing spreader thread guide

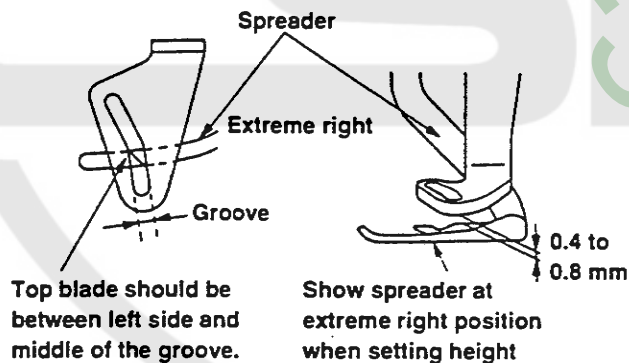

- When the spreader is in the extreme right position, the top blade of the spreader should be between left side and middle of the spreader thread guide groove.
- The height is 0.4 to 0.8 mm from the surface of the spreader.

⑤ Needle clamp spreader thread guide

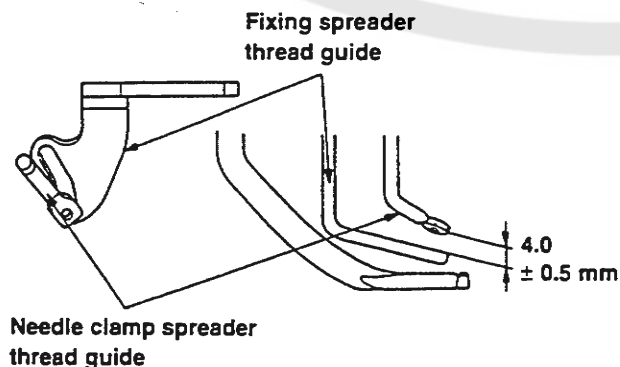

- When the needle bar is in the lowest position, the clearance between the needle clamp spreader thread guide and the upper face of the fixing spreader thread guide is 4.0 ± 0.5 mm.
- The center of the hole of the thread guide aligns with the left side of the fixing spreader thread guide groove.

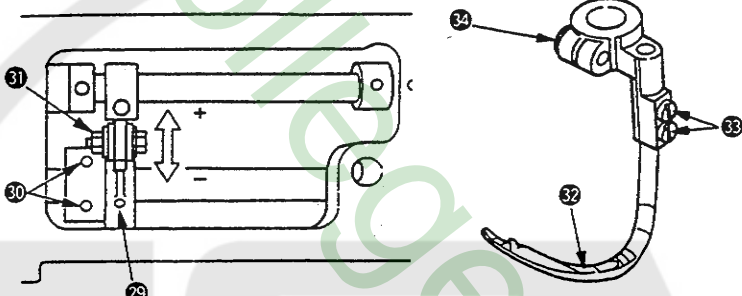
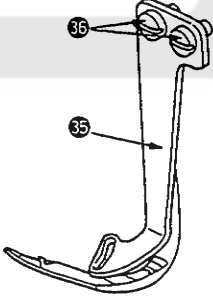
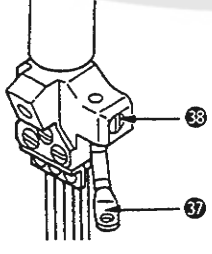
Adjustment Procedures	Results of Improper Adjustment
<ul style="list-style-type: none"> ○ Adjust the timing by loosening screw 30 of the spreader eccentric cam 29 and rotate the spreader eccentric cam 29 . ○ Adjust the stroke by loosening the nut 31 and move back and forth. If it is moved toward you, the stroke becomes small, and to the back it becomes large. ○ Adjust the height of the spreader by loosening the screw 33 and moving the spreader 32 up and down. ○ Adjust the clearance between the spreader and left needle by loosening the screw 33 and move the spreader 32 back and forth. ○ Adjust the extreme left position by loosening the screw 34 and move the spreader 32 to the left and right. 	<ul style="list-style-type: none"> ○ If the timing is too advanced, the needle does not catch the covering thread when it descends. This is likely to cause the skipping stitch. On the contrary, if the timing is too retarded, the right needle is likely to break as the resistance when the covering thread is pulled from the spreader becomes large. ○ If the movement amount of the spreader is not set right, it will cause skip stitching of the top covering thread. ○ If the height of the spreader is not set right, it will cause skip stitching of the top covering thread. ○ If the clearance between the spreader and needle is small, it will cause the needle breakage. If it is large, it will cause skip stitching of the top covering thread. ○ If the protruding amount of the spreader is large, it will cause uneven stitching of the top covering thread. If it is small, it will cause skip stitching of the top covering thread.
<ul style="list-style-type: none"> ○ Adjust the fixing spreader thread guide 35 by loosening the screw 36 . 	<ul style="list-style-type: none"> ○ If the height of the fixed spreader thread guide is set as high as 0.8 , the top covering performance by the spun thread is improved. But, defective looping may occur when other threads are used. ○ If the position of the fixed spreader thread guide is not correct, it will cause skip stitching of the top covering thread.
<ul style="list-style-type: none"> ○ Adjust the needle clamp spreader thread guide 37 by loosening the screw 38 . 	<ul style="list-style-type: none"> ○ If the position of the needle clamp spreader thread guide is not correct, it will cause skip stitching of the top covering thread.

Standard Adjustment

10) Looper thread cam

① Timing

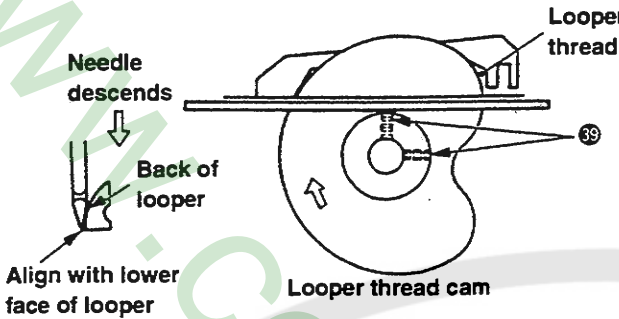

- When the looper thread is pulled from the highest point of the looper thread cam, the top point of the left needle aligns with the lower face of the looper.

② Position of looper thread guide plate and looper thread cam pawl wire

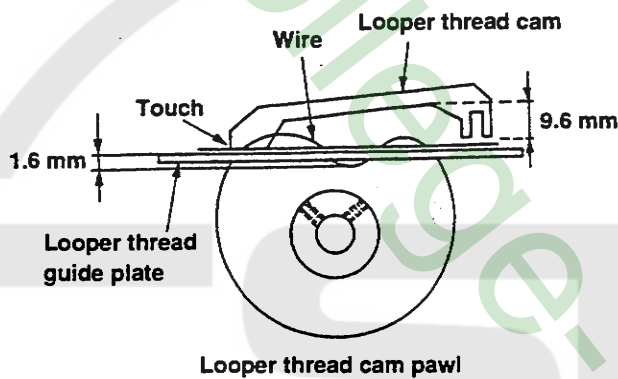

- The height of the looper thread guide plate is 1.6 mm from the lowest part of the looper cam to the upper part of the looper thread guide plate.
- The rear side of the looper thread cam pawl touches the wire, and its front side is 9.6 mm above the upper face of the wire at the highest place of the inside.
- The looper thread cam pawl and wire are to be positioned in the center of the looper thread cam plate.

③ Position of thread guide and auxiliary thread tension

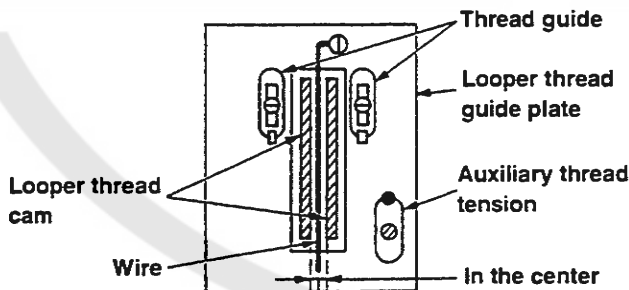

- The position of the thread guide is to be set at the position that the looper thread just becomes tight when the looper is in the extreme left.
- Adjust the tension of the auxiliary thread tension to make as low as the thread is just stabilized.

11) Position of the presser bar

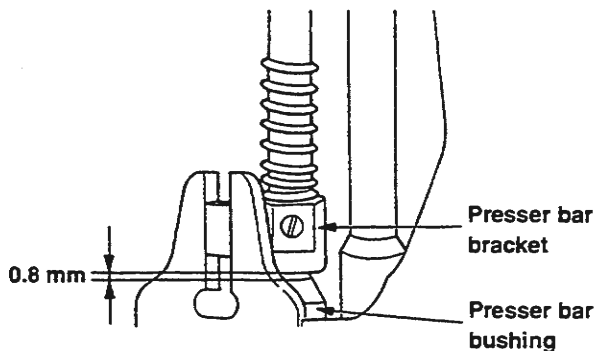

The clearance between the presser bar bracket and the presser bar bushing is 0.8 mm when the feed dog is under the throat plate and the bottom face of the presser foot touches the upper face of the throat plate at the time that the needle bar is in the lowest point.

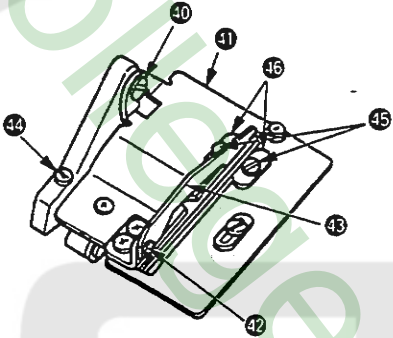
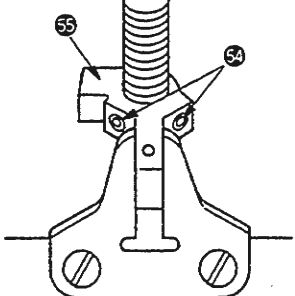
Adjustment Procedures	Results of Improper Adjustment
<ul style="list-style-type: none"> ○ Adjust the timing of the looper thread cam by loosening the two screws 39. ○ Adjust the height of the looper thread guide plate by loosening the screw 40 and move the looper thread guide plate 41 up and down. <p>Adjust the looper thread cam pawl by loosening the screw 42 and move the looper thread cam pawl 43 up and down.</p> <p>Adjust the lateral relation of the looper thread guide plate by loosening the screw 44 and move the looper thread guide plate 41 to the left and right.</p>  <p>(Caution) Use a 3/32" hexagonal wrench for the screw 39.</p> <ul style="list-style-type: none"> ○ Adjust the position of the thread guide by loosening the two screws 45 and move the thread guide 46 (2 pcs.) up and down. 	<ul style="list-style-type: none"> ○ If the timing of the looper thread cam is too advanced, the skip stitching on the back of the looper will occur. If it is too retarded, the tightening of the thread will be inferior. ○ If the clearance between the looper thread cam pawl and the wire is large, the looper thread suddenly slackens and skip stitching on the back side will occur. ○ If the looper thread cam is not in the center, the cam will be damaged. <ul style="list-style-type: none"> ○ If the thread guide is raised, the looper thread after sewing will be slack. ○ If the thread guide is lowered, the looper thread after sewing will be tight.
<ul style="list-style-type: none"> ○ Adjust by loosening the two screws 54 and move the presser bar bracket 55 up and down. 	<ul style="list-style-type: none"> ○ If the clearance between the presser bar bracket and the presser bar bushing is small, the bottom face of the presser foot can not contact tightly to the throat plate. ○ If the clearance is large, the lifting amount of the presser foot will be reduced.

Standard Adjustment

12) Position of the needle thread tension release (without thread trimmer)

When the presser foot is raised by 3 mm, the thread tension opening pawl ③ touches the thread tension ④ and when the presser foot is in the highest position, the thread tension disc opens and there is no tension on the thread.

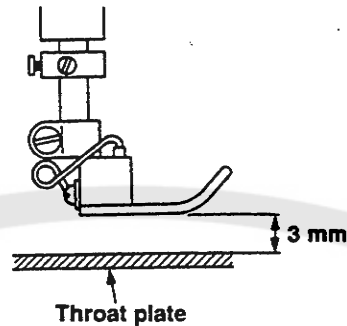

13) Position and height of the presser foot

- ① Adjust the position of the presser foot so that the needles enter the center of the needle entry holes in the presser foot on condition that the presser foot is set correct to the presser bar.
- ② Adjust the height of the presser foot so that when the needle bar is in its highest point, the needle point does not come out from the lower face of the presser foot.

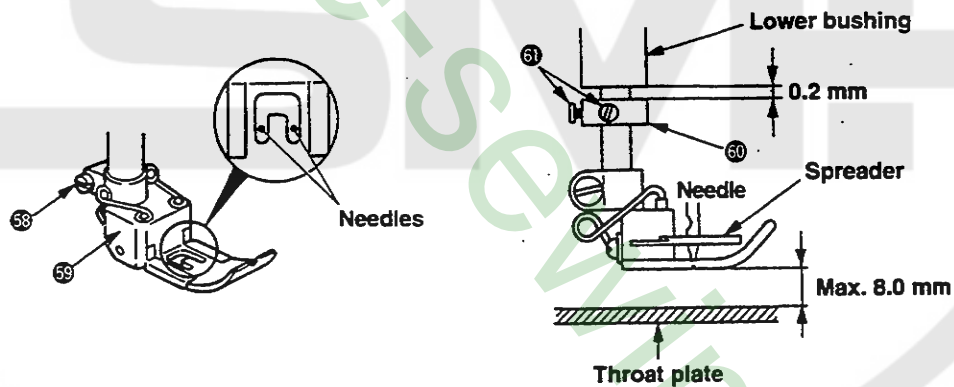

Note: On elastic machines height is 7.0 mm.

14) Position of the thread guide

- ① Middle thread guide and thread guide holder

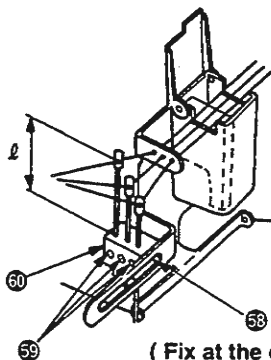

	l		
	Left needle thread	Middle needle thread	Right needle thread
Spun thread	27 mm	25 mm	23 mm
Cotton thread	27 mm	25 mm	23 mm
Wooly nylon thread	27 mm	25 mm	23 mm
Tetoron thread	27 mm	25 mm	23 mm

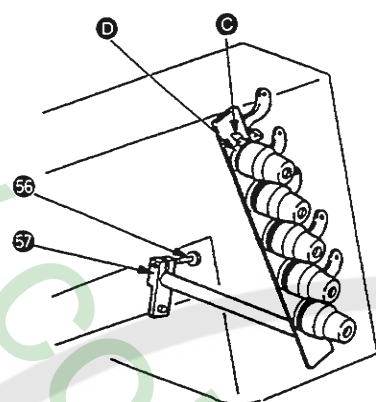
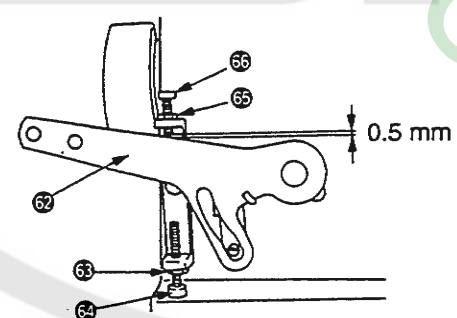
Adjustment Procedures	Results of Improper Adjustment
<p>○ Adjust by loosening the screw 56 and move the bracket 57.</p> 	
<p>○ Adjust the position by loosening the screw 58 and move the presser foot 59 to the left and right.</p> <p>○ Adjust the height by loosening the nut 60 and rotate the screw 61 and hit it to the lever 62 so that the needle top comes 0.3 mm over from the lower part of the presser foot when the needle is in its highest point. At this time, loosen the two screws 61 and fix the collar 60 so that the clearance between the collar and the lower bushing is 0.2 mm.</p> <p>Adjust by loosening the nut 63 and rotate the screw 64 so that the clearance between the top end of the screw 64 and the lever 62 becomes 0.5 mm on condition that the presser foot descends and rests tightly on the throat plate.</p> 	<p>○ If the position of the presser foot is not correct, it will cause defective and non-straight sewing.</p> <p>○ If the height of the presser foot is not correct, it will cause breakage of the spreader, the needle scratch on workpiece, defective sewing and the lack of feeding force.</p>
<p>○ Loosen the screw 58 and fix the thread guide attaching base 60 to the extreme right. Loosen the screw 59 and adjust the respective heights l referring to the left table. Make the fine adjustment watching the actual stitching.</p>	<p>○ If it is raised, the needle thread is tightened.</p> <p>○ If it is lowered, the needle thread slackens.</p> <p>○ The tightened stitches of the right needle and left needle can be simply slackened if the thread guide holder is moved to the left.</p>

Standard Adjustment

② Needle bar needle thread release

- When the loop of the needle thread is not easily formed, raise the needle thread release as shown in the figure at the time of the lowest point of the needle bar.

Lowest point of needle bar

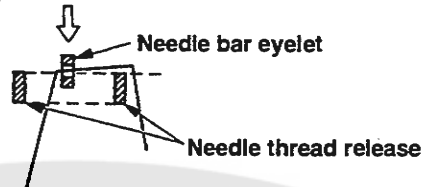

- If the needle thread is a cotton thread, raise the right needle thread release so that the right needle thread only touches at the time of the lowest point of the needle bar.

Lowest point of needle bar

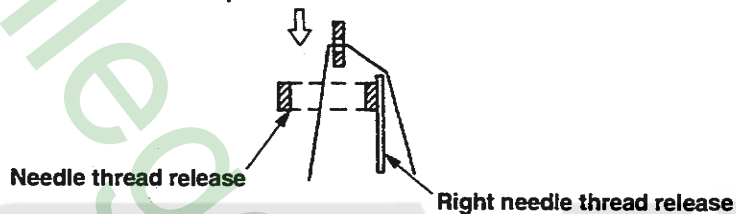

- If the needle thread is a spun thread, lower the needle thread release so that the needle thread does not touch it.

Lowest point of needle bar

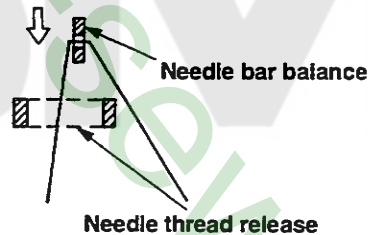

③ Spreader balance thread guide

It should be positioned that the top covering thread does not slacken and the spreader does not pull out the thread, when the spreader has moved to the extreme left position.

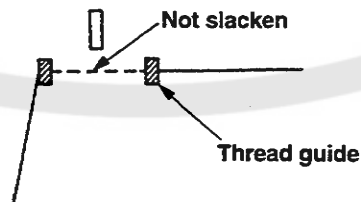

④ Needle thread nipper

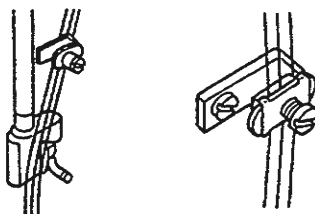

All the needle threads are to be threaded through the needle thread nipper, except the cotton and teteron type threads.

Adjustment Procedures

- Loosen screw 61 and adjust by moving the needle thread release 62 up and down.
- Loosen screw 63 and adjust by moving the right needle thread release 64 up and down.

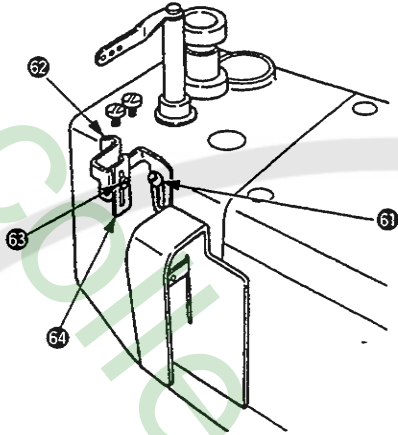

- Loosen screw 65 and adjust by moving the thread guide 66 up and down.

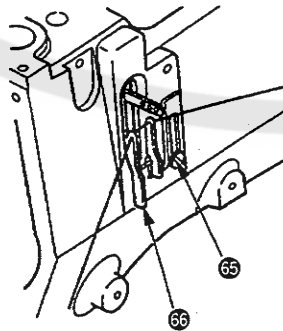

Results of Improper Adjustment

- If it is raised, the loop of the needle thread becomes larger.
- If it is lowered, the loop of the needle thread becomes smaller.
- If the loop is not formed (the loop is too small) and skip stitching occurs, raise the needle thread release.
- If the loop is excessively formed (the loop is too large) and the skip stitching occurs, lower the needle thread release.

- If it is raised, the thread slackens.
- If it is lowered, the thread tightens.

- Use of the nipper depending on the threads to be used.

Not used for cotton thread and tetoron thread.

Used for wooly nylon thread and spun thread (stretching thread).

Standard Adjustment

1) Needle feed timing

First screw **A** in operating direction on double eccentric **B** of feed drive assembly must be straight up, when the needle bar is at top of stroke.

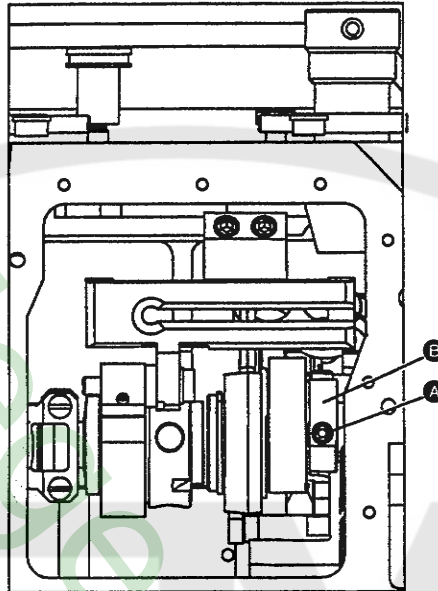

2) Adjusting the timing of the needle bar and looper (Synchronization) : Without Gauges

When the blade point of the looper moves to the left in the rear of the needle and to the right in the front of the needle, and the top end of the hole of the left needle aligns with the lower part of the looper, the distance between the left side of the left needle and the blade point of the looper should be equal to the distance A and B.

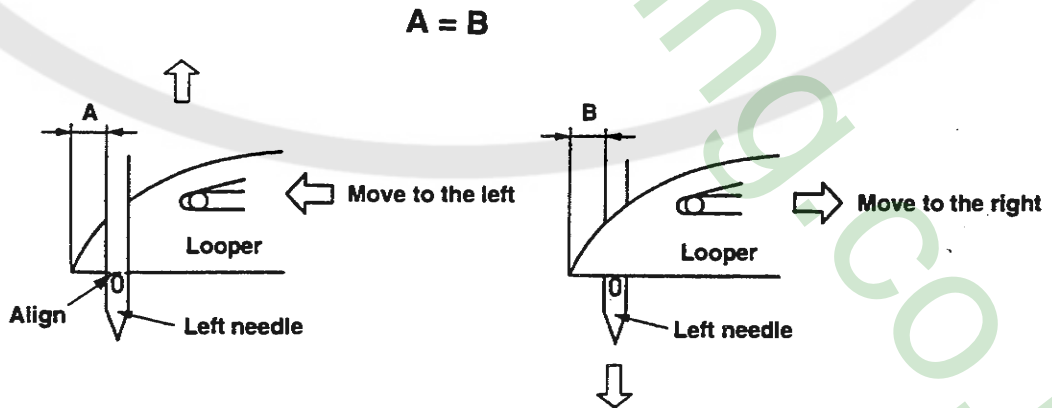

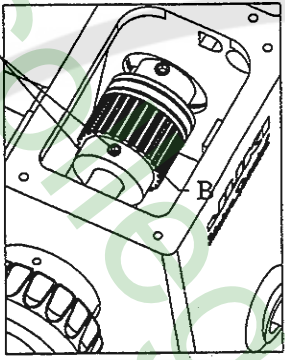
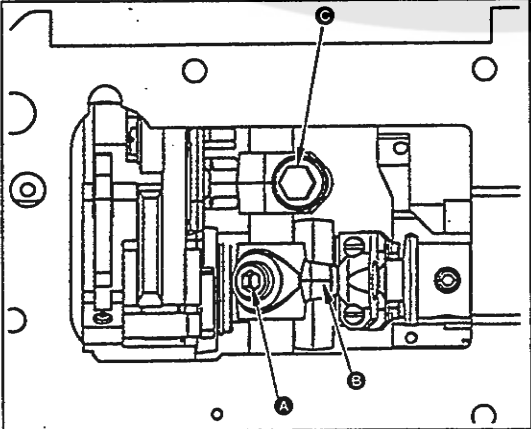
Adjustment Procedures	Results of Improper Adjustment
<ul style="list-style-type: none"> • Remove top cover, oil reservoir cover, gasket and cloth plate. • Loosen screws (C) of sprocket (D). • Rotate lower main shaft in operating direction clockwise, until the first screw (A) on double eccentric (B) is straight up. • Holding pulley to prevent it from turning, rotate handwheel of upper main shaft until needles are at top of their stroke. • Torque screw (C) to 45–46 in. lbs. (5.2–5.4Nm). • Replace top cover, oil resevoir cover, gasket and cloth plate.  <p>Note: Earlier machines have (4) screws.</p>	<ul style="list-style-type: none"> • Needle breakage • Loper missing needle thread
<ul style="list-style-type: none"> • Turn handwheel in operating direction until bottom of looper is even with top of needle eye. Note dimension (A) • Continue turning handwheel in operating direction until bottom of looper is even with top of needle sye when looper is in front of needle. Note dimension (B) • If (A) is greater than (B) <ul style="list-style-type: none"> –Loosen (C) in connector (D). –Move connector (D) away from connector (E) –Tighten (C) –Repeat above two steps until (A) = (B) • If (A) less than (B) <ul style="list-style-type: none"> –Loosen screw (C) in connector (D) –Move connector (D) toward (E) –Tighten (C) –Repeat sobve two steps until (A) = (B)  <p style="text-align: center;">Fig. 7</p>	<ul style="list-style-type: none"> • If the timing is not set right, it is likely to occur skipping and tangling stitches.

Standard Adjustment

2) Synchronizing looper and needle motions : With Gauges

- Set looper to its extreme right position.
- Rotate handwheel clockwise until looper has moved .400" (10 mm) from right to left.
- Set indicator point to "0" on top of needle bar.
- Move looper to its extreme right position by turning handwheel counterclockwise.
- Continue rotating handwheel counterclockwise until looper has moved .400" (10 mm) in that direction.
- Indicator point should return to "0" in that direction.
- Synchronization is correct when looper moves .400 (10 mm) back and forth (clockwise and counterclockwise and dial indicator on needle bar moves to zero in each direction.

(Note)

Synchronization can only be obtained after needle/feed timing has been set, and only by moving looper drive lever rocker shaft until synchronization has been obtained.

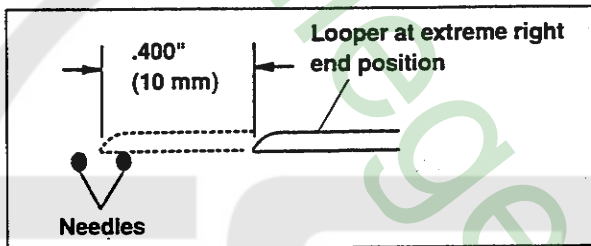

Fig.1 Clockwise

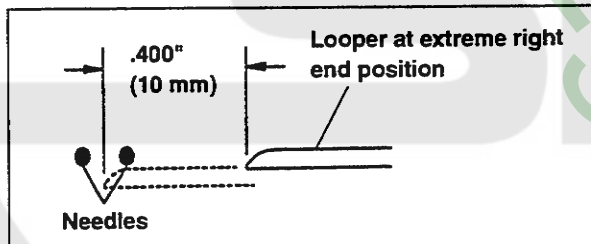

Fig. 2 Counterclockwise

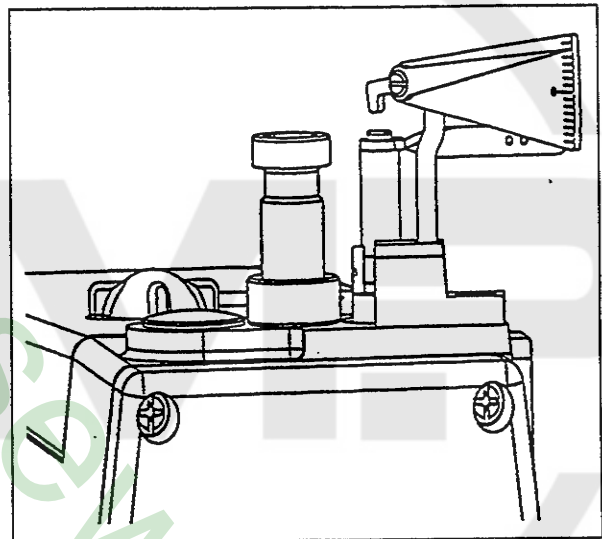

Fig. 3

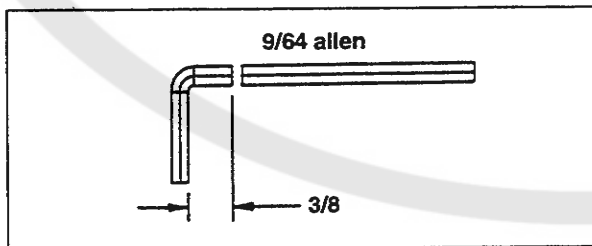

Fig.4

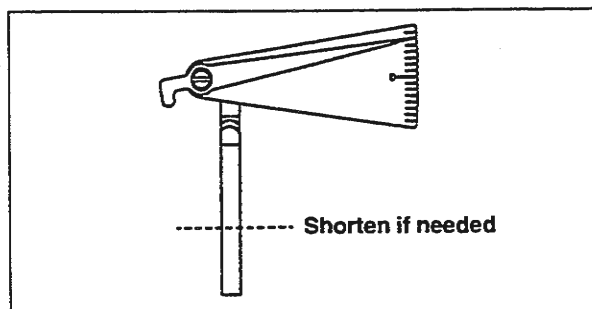

Fig. 5

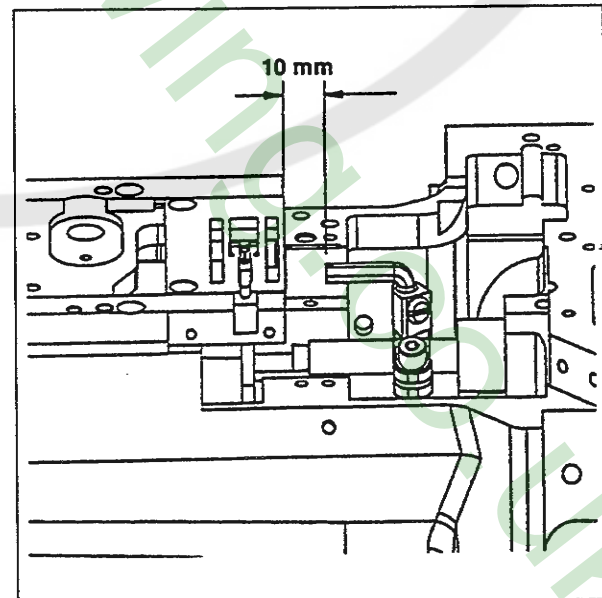
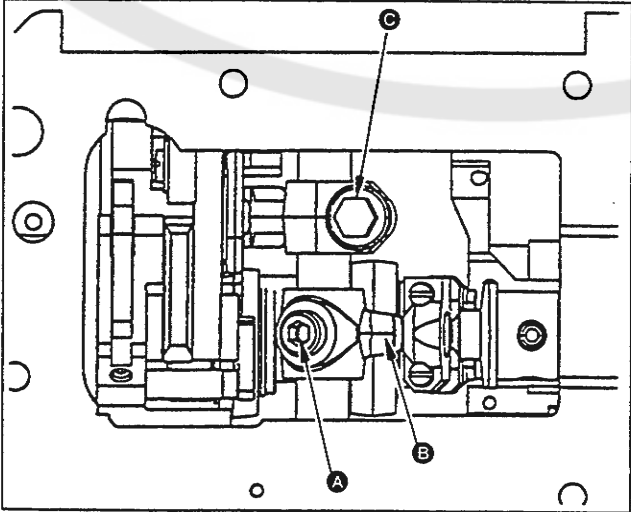

Fig. 6

Adjustment Procedures	Results of Improper Adjustment
<ul style="list-style-type: none"> ○ Drain oil. ○ Remove oil pan. ○ Modify a standard 9/64" allen wrench (Fig.4). ○ Flag indicator from TT146 may need to be shorten (Fig. 5). ○ Remove looper and mount modified allen wrench in looper holder. ○ With needle bar at bottom dead center adjust looper holder so allen wrench is .400" (10 mm) from throat plate (Fig. 6). ○ Turn machine in operating direction until allen wrench contacts throat plate, assemble indicator to top of machine as shown in (Fig. 3) and set indicator point to "0". ○ Turn machine in opposite direction until allen wrench contacts throat plate. <p>(Note)</p> <p>Reading of indicator.</p> <p>If distance is less than "0".</p> <ul style="list-style-type: none"> • Loosen screw A (Fig. 7). • Move drive lever crank B away from looper rocker lever C. • Retighten screw A. • Recheck indicator readings in both rotating directions, until they are the same, +/- 1 mark. • Torque screws A. <p>If distance is more than "0".</p> <ul style="list-style-type: none"> • Loosen screw A (Fig. 7). • Move drive lever crank B towards looper rocker lever C. • Retighten screw A. • Recheck indicator readings in both rotate directions, until they are the same, +/- 1. • Torque screw A to 130 in. lbs. (15 Nm). • Replace removed parts. • Refill with UNION SPECIAL 175 oil. (Part No. 28604R)  <p>The diagram, labeled Fig. 7, shows a side view of the looper mechanism. It features a central drive lever crank (B) that can move horizontally. A screw (A) is used to adjust the tension of the drive lever. A looper rocker lever (C) is positioned to the right of the drive lever crank. The diagram illustrates how the distance between the drive lever crank and the looper rocker lever is adjusted by moving the drive lever crank towards or away from the rocker lever.</p> <p style="text-align: center;">Fig. 7</p>	<ul style="list-style-type: none"> ○ Skipped stitches

Standard Adjustment

3) Returning amount of the looper

When the looper is at the extreme right position, the distance between the blade point of the looper and the center of the right needle is 4.8 ± 0.1 mm.

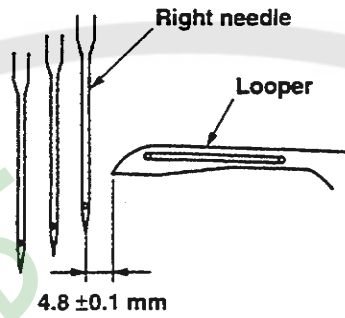

Adjustment Procedures	Results of Improper Adjustment
<p data-bbox="284 226 982 294">○ Adjust the returning amount by loosening the looper holder binder screw ④.</p> 	<p data-bbox="1031 226 1469 373">If the returning amount is large, skipping stitch and tangling stitch will occur. And the thickness of the material to be sewn will be reduced.</p> <p data-bbox="1031 384 1469 489">If the returning amount is small, skipping stitch and tangling stitch will occur.</p>

Standard Adjustment

4) Height of the needle bar

When the looper moves to the left and the point of the looper comes out from the left side of the left needle by 1.0 ± 0.3 mm, the lower part of the looper aligns with the top end of the hole of the left needle.

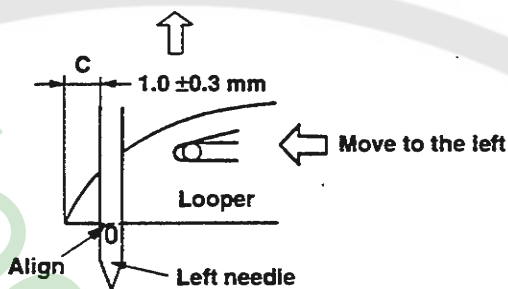

5) Position of the needle guard

- ① The height of the rear needle guard is adjusted so that the point of the right needle comes to the $1/2$ height of the contact surface of the rear needle guard when the blade point of the looper aligns with the right side of the right needle.

The pushing amount is 0 to 0.1 mm to all needles.

(The blade point of the looper should not contact the respective grooves of the all needles.)

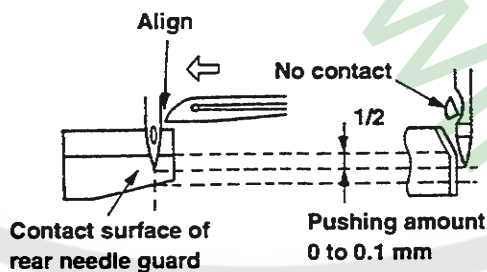

- ② The height of the front needle guard is 2.0 ± 0.1 mm from the lower part of the looper. The face of the guard position is parallel to all needles having a clearance of 0.25 ± 0.1 mm.

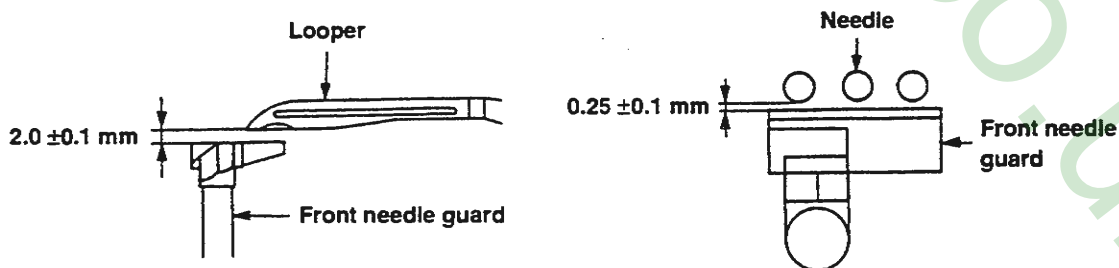

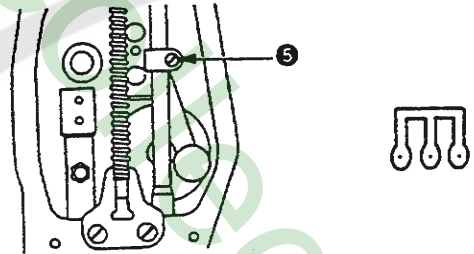
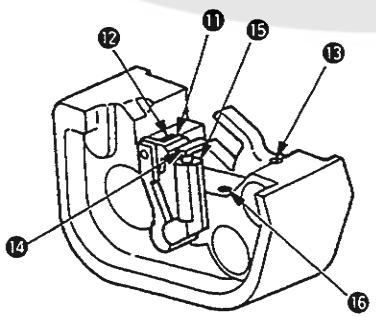
Adjustment Procedures	Results of Improper Adjustment
<ul style="list-style-type: none"> Loosen the screw ⑤ of the needle bar binder bracket inside the face cover and adjust the height of the needle bar. <p>(Caution) After the adjustment, check that the direction of the needle head is right and that the respective needles enter the center of the holes of the throat plate.</p> 	<p>If the measurement of C is large, skip stitching and thread tangling occur.</p> <p>If the measurement of C is small, skip stitching and thread tangling occur.</p>
<ul style="list-style-type: none"> Adjust the height of the rear needle guard by loosening the screw ⑫ and move the rear needle guard ⑪ up and down. Adjust the pushing amount by loosening the screw ⑬ and move the rear needle guard back and forth. Adjust the height of the front needle guard by loosening the screw ⑮ and move the front needle guard ⑭ up and down. Adjust the inclination at the same time. Adjust the clearance for the needle by loosening the screw ⑯. <p>(Caution) Use a 3/32" hexagonal wrench for the screw ⑮. Check that there is no looseness on the left/right sides of the rear needle guard when tightening the screw ⑮.</p> 	<ul style="list-style-type: none"> If the clearance between the rear needle guard and the needle is large, it causes the skipping stitch, the damage of the blade point of the looper and needle breakage. If the rear needle guard and the needle hits strongly, it will cause the damage of the needle top. If the clearance between the front needle guard and the needle is large, the loop becomes small and the skipping stitch will occur. If the front needle guard and the needle hits strongly, the loop becomes large and the skipping stitch, the damage of the needle point and the damage of the blade point of the looper will occur.

Standard Adjustment

6) Clearance between the looper and needle

Clearance between the blade point of the looper and the grooves of the right and left needles is 0 to 0.05 mm.

(Clearance of the middle needle is a little larger.)

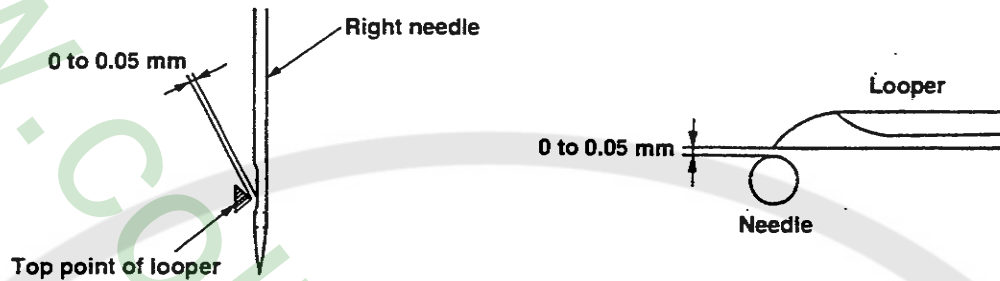

7) Adjusting amount of the looper-avoid

- The clearance between the blade point of the looper, and the grooves of the left and right needles should be equal.



- When the looper moves to the right, the tip of the left needle contacts the back of the looper at the position of 2/3 from the upper side of the looper.

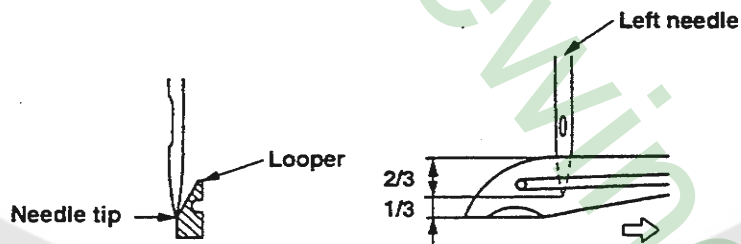

(Adjust when the needle is replaced with an excessively different sized needle. Check that the clearance between the looper and the needle is correct and the needle tip contacts the back of the looper at the position of 2/3 from the upper side of the looper.)

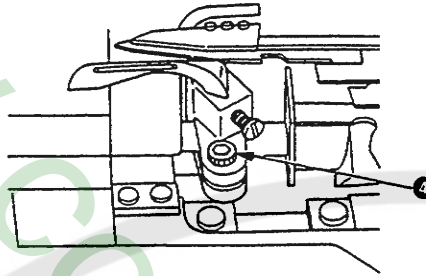
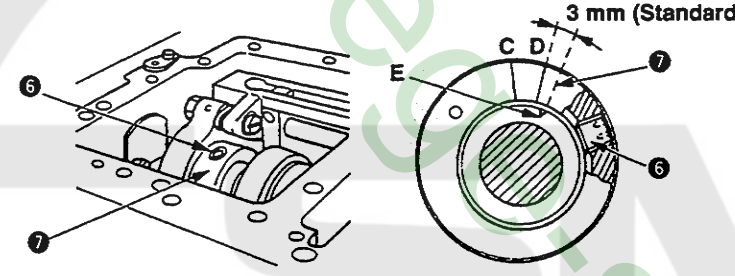
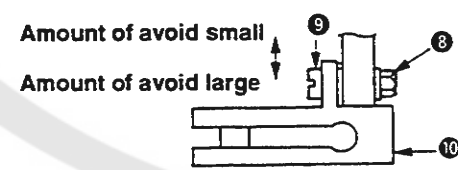
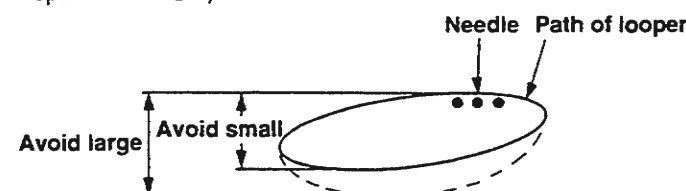
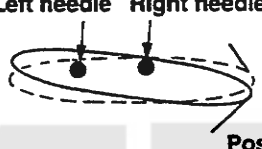
Adjustment Procedures	Results of Improper Adjustment
<p>○ Adjust by loosening the looper base setscrew ④ and move the looper holder back and forth.</p> 	<ul style="list-style-type: none"> ○ If the clearance is large, skipping stitch of the needle thread scooping occurs. And the damage of the needle point will occur due to the strong hit on the back of the looper. ○ If the clearance is small, the damage of the blade point of the looper and the needle breakage will occur. And, the skipping stitch will occur as the clearance between the back of the looper and the needle becomes large.
<p>① Adjustment of looper path</p>  <p>Loosen the setscrew ⑥ of the looper path shifting cam ⑦. Place the engraved line D about 3 mm from the engraved line E and rotate the cam ⑦ to adjust so that the clearance between the right/left needles and the blade point of the looper should be equal.</p> <p>② Adjustment of avoid</p>  <p>Amount of avoid small Amount of avoid large</p> <p>Loosen the screw ⑨ and nut ⑧ of the looper cam guide ⑩. Then move the screw ⑨ back and forth to adjust. (Use a 3/8" spanner for ⑧.)</p>  <p>Needle Path of looper</p> <p>Avoid large Avoid small</p> <p>(Caution) After the adjustment, check again the clearance between the blade point of the looper and the groove of the needle. Use a 1/8" hexagonal wrench for the screw ⑥.</p>	<p>Left needle Right needle</p>  <p>Position of D-C</p> <ul style="list-style-type: none"> ○ Looper path between the engraved lines D and C is left upward. The clearance of the left needle is large and skipping stitch occurs. ○ If the engraved line E is turned more than 3 mm from D, the looper path is left downward. The damage of the blade point of the looper and needle breakage occur. ○ If the amount of avoid is large, the clearance between the needle and the back of the looper becomes large. In this case, skipping stitch and tangling stitch occur. ○ If the amount of avoid is small, the hitting of the needle and the back of the looper becomes strong. In this case, the damage of the needle top, needle breakage and scratch on the back of the looper occur.

Standard Adjustment

8) Position of the feed dog

- The clearance between the slot on the throat plate and the left/right sides of the feed dog should be equal.
- In the maximum stroke end of the main feed dog and differential feed dog, the clearance should be equal to $A = A'$ and $B = B'$.
- Height of the feed dog is 1.0 mm at the top of their stroke.
- Tilt of the feed dog is parallel to the throat plate when the needle bar is in its highest position.

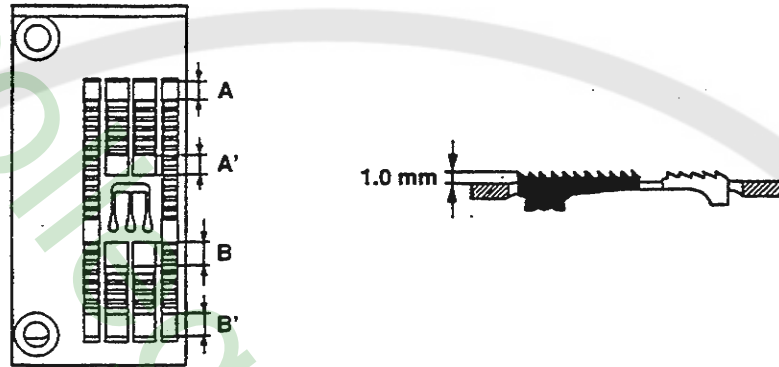

- Adjust so that the throat plate and the main feed dog do not contact each other even if the main feed dog is in its maximum stroke end.

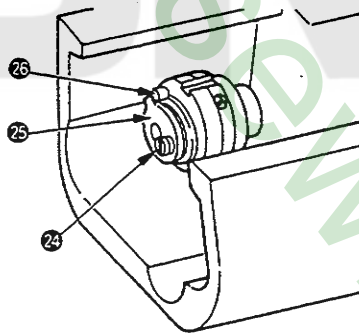

- Adjust so that the throat plate and the differential feed dog do not contact each other even if the stroke is maximized.

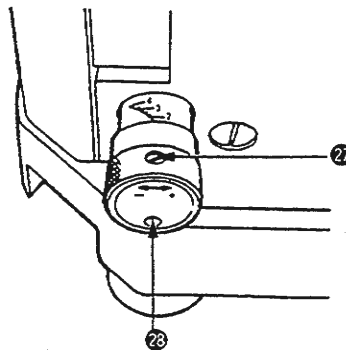

Adjustment Procedures

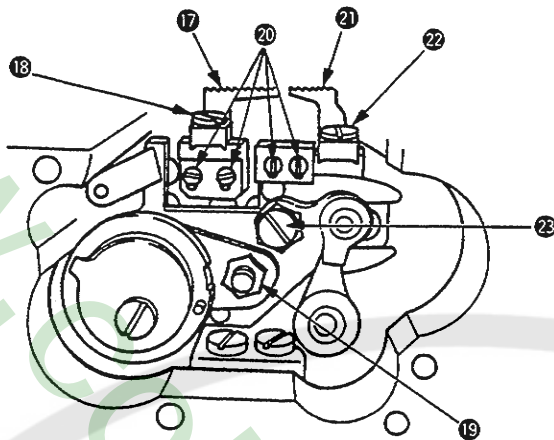

- Loosen screw 18 to adjust the left/right position of the main feed dog 17 .
- Loosen screw 22 to adjust the left/right position of the differential feed dog 21 .
- Loosen screw 19 and move the main feed dog back and forth to adjust the longitudinal position of the main feed dog 17 .
- Loosen screw 23 and rotate the eccentric nut to adjust the longitudinal position of the differential feed dog 21 .
- Loosen screw 20 to adjust the height of the main feed dog 17 and the differential feed dog 21 .
- To adjust the maximum stroke of the main feed dog, loosen screw 24 and rotate spacing stop 25 so that it contacts the pin 26 when the main feed dog has reached its maximum stroke and while the throat plate does not contact the main feed dog.
- To adjust the maximum stroke of the differential feed dog, loosen screw 27 and enter the stopper pin 28 to the end when the differential feed dog has reached its maximum stroke and while the differential feed dog does not contact the throat plate and the front end of the main feed dog.

Results of Improper Adjustment

- If the lateral position of the feed dog is not correct, the left/right sides of the feed dog and the throat plate will wear out. Heating and abnormal noise will be produced. Also, the feed components will wear out quickly and looseness and bending of the components will occur. Also, abnormal noise from the components will be produced.
- If the height of the feed dog is low, the stitch length at the finish of sewing becomes smaller.
- If the height of the feed dog is high, it will cause the return feed, skipping stitch and defective chain-off.
- If the main feed dog, differential feed dog, and throat plate come in contact with each other, it will cause breakage.

9) Spreader

① Timing

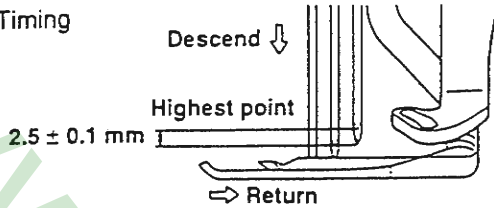

Just when the needle descends 2.5 mm from the highest point of the needle bar, the spreader begins to return from its extreme left position.

② Stroke

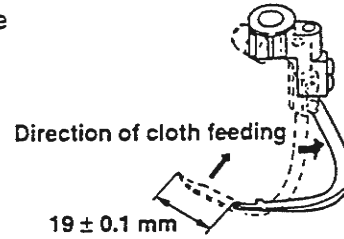

③ Position of spreader

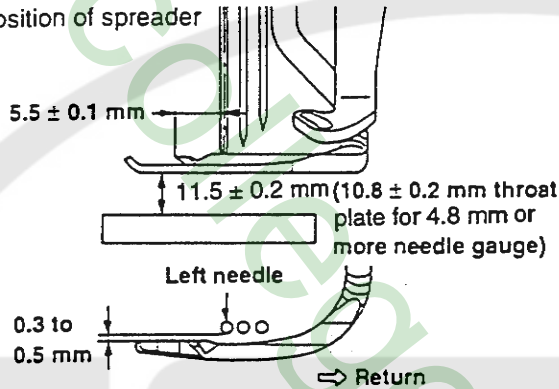

- The height is 11.5 ± 0.2 mm ($4.0 + 3.2$ gauge). (10.8 ± 0.2 mm for 4.8 mm, 5.6 mm, and 6.4 mm gauges).
- When the spreader is in the extreme left position, the distance between the center of the left needle and the top blade of the spreader is 5.5 ± 0.1 mm.
- When the spreader returns to the right, the clearance between the spreader and the left needle is 0.3 to 0.5 mm.

④ Fixing spreader thread guide

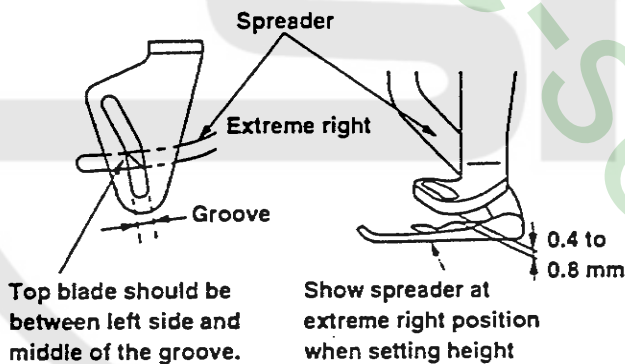

- When the spreader is in the extreme right position, the top blade of the spreader should be between left side and middle of the spreader thread guide groove.
- The height is 0.4 to 0.8 mm from the surface of the spreader.

⑤ Needle clamp spreader thread guide

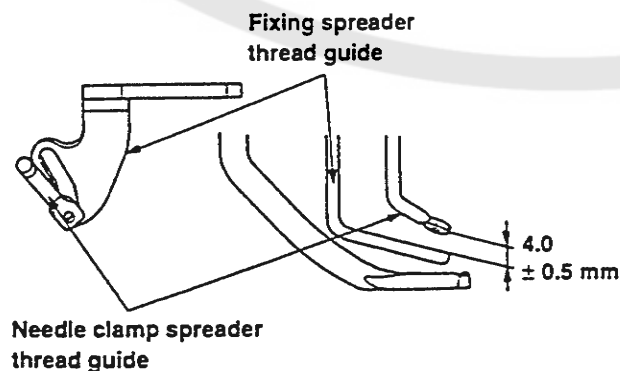

- When the needle bar is in the lowest position, the clearance between the needle clamp spreader thread guide and the upper face of the fixing spreader thread guide is 4.0 ± 0.5 mm.
- The center of the hole of the thread guide aligns with the left side of the fixing spreader thread guide groove.

Adjustment Procedures

Results of Improper Adjustment

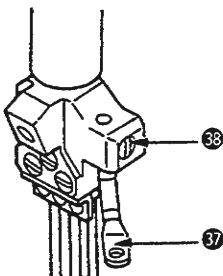
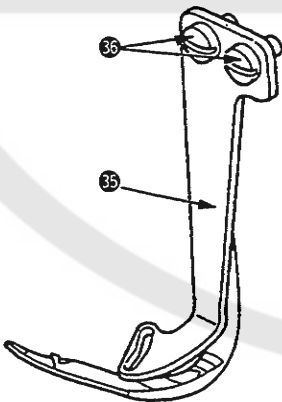
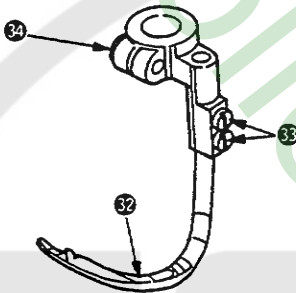
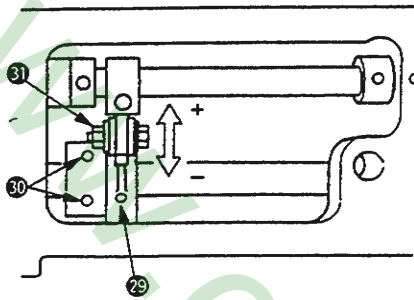

- Adjust the timing by loosening the screw 30 of the spreader eccentric cam 29 and rotating the spreader eccentric cam 29.
- Adjust the stroke by loosening the nut 31 and moving it back and forth. If it is moved toward you, the stroke becomes small. If it is moved to the back, the stroke becomes large.
- Adjust the height of the spreader by loosening the screw 33 and move the spreader 32 up and down.
- Adjust the clearance between the spreader and the left needle by loosening the screw 33 and moving the spreader 32 back and forth.
- Adjust the extreme left position by loosening the screws 34 and move the spreader 32 to the left and right.
- Adjust the fixed spreader thread guide 35 by loosening the screws 36.
- Adjust the needle clamp spreader thread guide 37 by loosening the screw 38.

- If the timing is too advanced, skipping stitch is likely to occur as when the needle descends, the needle does not catch the covering thread. If the timing is too retarded, the right needle is likely to be broken as the resistance of the covering thread becomes strong when it passes the covering thread looper.
- If the movement amount of the spreader is not set right, skipping stitch of the top covering thread occurs.
- If the height of the spreader is not set right, skipping stitch of the top covering thread occurs.
- If the clearance between the spreader and the needle is small, the needle breaks. If it is large, skipping stitch of the top covering thread occurs.
- If the protruding amount of the spreader is large, uneven stitch of the top covering thread occurs. If it is small, skipping stitch of the top covering thread occurs.
- If the height of the fixed spreader thread guide is set about 4 mm, the performance of the top covering with the spun thread is improved. But, for other threads, it is likely to cause the defective pick-up of the thread.
- If the position of the fixed spreader thread guide is not set right, skipping stitch of the top covering thread occurs.
- If the position of the needle clamp spreader thread guide is not set right, skipping stitch of the top covering thread occurs.

Standard Adjustment

10) Loper thread cam

① Timing of the looper thread cam

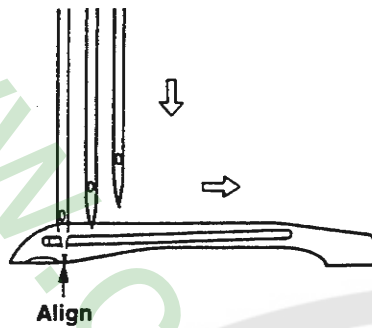

When the needle bar descends and the tip of the left needle aligns with the lower part of the looper, the looper thread can be cast off from the highest point of the looper cam.

② Position of the looper thread cam thread guide

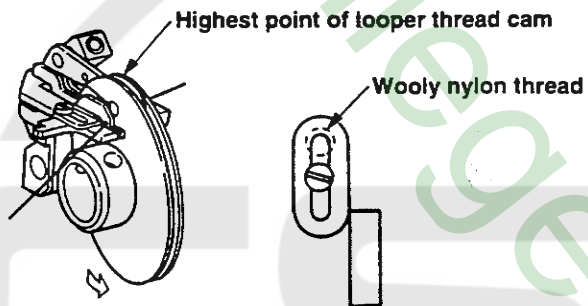

The looper thread cam thread guide is to be set in the center of the slot.
(In case of woolly nylon thread, at the upper end of the slot.)

Adjustment Procedures	Results of Improper Adjustment
<p>Looper thread</p> <p>○ Timing of the looper thread cam is adjusted by loosening the screw 48 and rotating the looper thread cam 45 .</p> <p>At this time, set so that the collar 50 contacts 45 . In case of lateral adjustment, loosen the screw 51 of the collar 50 and adjust on condition that the looper thread cam 45 contacts the collar 50 .</p> <p>○ Loosen the screw 48 for the parallel and the screw 49 for the clearance so that the middle latch 47 is parallel to the looper thread guide base and the clearance is 4.0 mm.</p> <p>○ Loosen the screws 52 and 41 , and adjust by moving the left needle thread guide 53 and the thread control finger 42 up and down.</p> <p>(Caution) Use a 3/32" hexagonal wrench for the screws 46 , 48 and 49 .</p>	<p>○ If the timing of the looper thread cam is too advanced, skip stitching on the back of the looper occurs. If the timing of the looper is too retarded, thread tightening is not well.</p> <p>○ If the looper thread cam is not set in the center, the cam is scratched.</p> <p>○ If the clearance between the middle latch and the looper thread guide base is more than 4 mm, the looper thread suddenly slackens and skip stitching on the back of the looper occurs.</p> <p>○ If the thread guide is raised too high, the looper thread after the sewing is finished becomes tight.</p> <p>○ If the thread guide is lowered too much, the looper thread after the sewing is finished becomes slack.</p>

Standard Adjustment

12) Position of the presser bar

When the feed dog is under the lower part of the throat plate and the bottom face of the presser foot contacts the upper face of the throat plate at the lowest point of the needle bar, the clearance between the presser bar bracket and the upper end of the presser bar bushing is 0.8 mm.

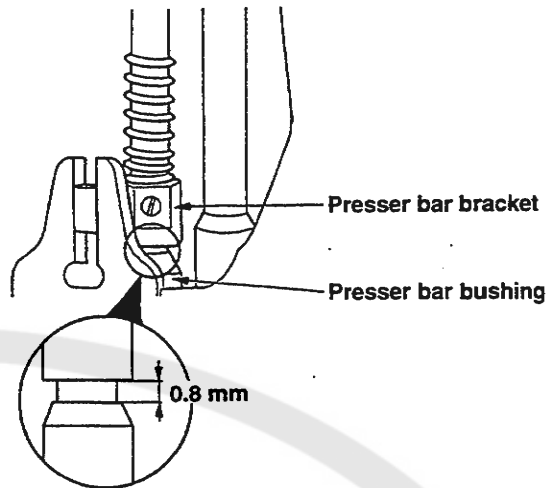

13) Position of the needle thread tension release (without thread trimmer)

When the presser foot is raised by 3.0 mm, the thread tension opening pawl (C) contacts the thread tension disc (D), and when the presser foot is raised at its highest point, the thread tension disc opens and there is no tension on the thread.

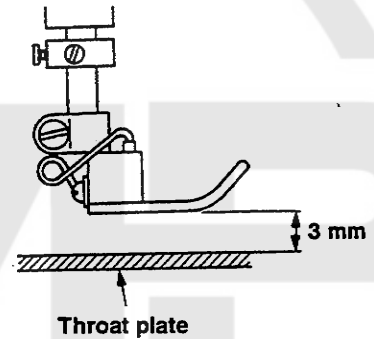

14) Position and height of the presser foot

- ① Adjust the position of the presser foot so that the needles are positioned to enter the centers of the holes of the needle entry of the presser foot on condition that the presser foot is set right to the presser bar.
- ② Adjust the height of the presser foot so that the needle top does not come out from the bottom face of the presser foot when the needle bar is in its highest point.

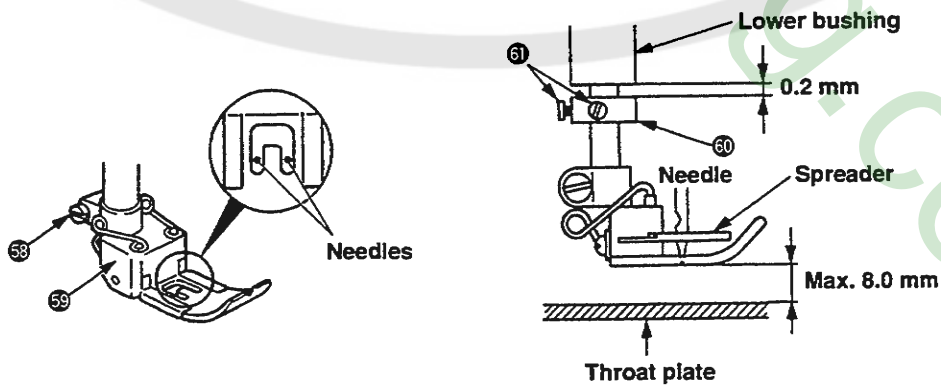

Note: On elastic machines height is maximum 7.0mm

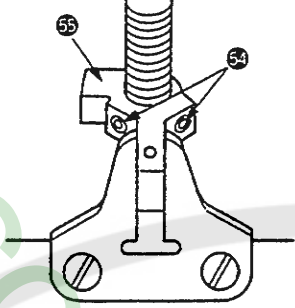
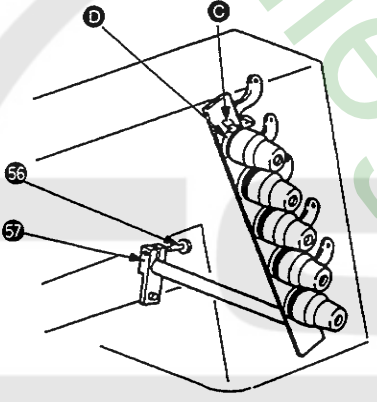
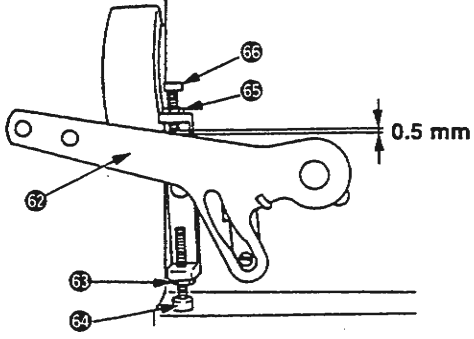
Adjustment Procedures	Results of Improper Adjustment
<ul style="list-style-type: none"> Loosen the two screws 54 and adjust the position by moving the presser bar bracket 55 up and down. 	<ul style="list-style-type: none"> If the clearance between the presser bar bracket and the presser bar bushing is too small, the bottom face of the presser foot is not closely fitted on the throat plate. If the clearance is too large, the lifting amount of the presser foot becomes small.
 <ul style="list-style-type: none"> Loosen screw 56 and adjust by moving the bracket 57. 	<p>Thread tension not being released. No tension during sewing.</p>
<ul style="list-style-type: none"> Adjust the position by loosening the screw 58 and moving the presser foot 59 to the left and right. Adjust the height by loosening the nut 63 and rotate the screw 64 and hit it to the lever 62 so that the needle tip comes 0.3 mm over from the lower part of the presser foot when the needle is in its highest point. At this time, loosen the two screws 61 and fix the collar 60 so that the clearance between the collar and the lower bushing is 0.2 mm. Adjust by loosening the nut 65 and rotate the screw 66 so that the clearance between the top end of the screw 66 and the lever 62 becomes 0.5 mm on condition that the presser foot descends and seats tightly on the throat plate. 	<ul style="list-style-type: none"> If the position of the presser foot is not correct, it will cause defective sewing and non-straight sewing. If the height of the presser foot is not correct, it will cause breakage of the spreader, needle scratch on workpiece, defective sewing and lack of the feeding force.

Standard Adjustment

15) Position of the thread guide

① Middle thread guide and thread guide attaching base

	l		
	Left needle thread	Middle needle thread	Right needle thread
Spun thread	16 mm	14.5 mm	13 mm
Cotton thread	16 mm	21 mm	21 mm
Wooly nylon thread	16 mm	21 mm	21 mm
Tetoron thread	16 mm	21 mm	21 mm

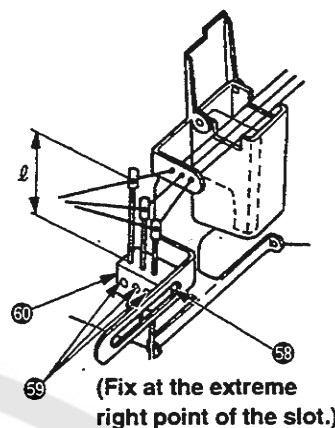

② Needle bar needle thread release

Lowest point of needle bar

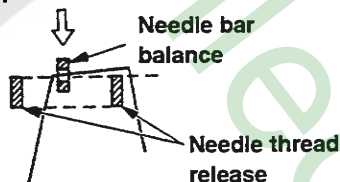

- When the loop of the needle thread is not easily formed, raise the needle thread release as shown in the left figure at the time of the lowest point of the needle bar.

Lowest point of needle bar

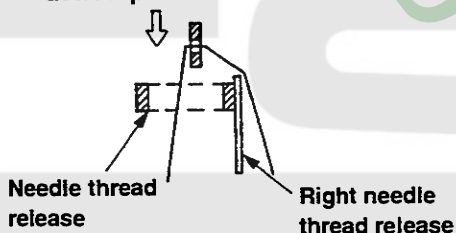

- If the needle thread is a cotton thread, raise the right needle thread release so that the right needle thread only touches at the time of the lowest point of the needle bar.

Lowest point of needle bar

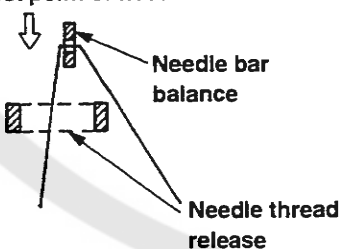

- If the needle thread is a spun thread, lower the needle thread release so that the needle thread does not touch it.

③ Spreader balance thread guide

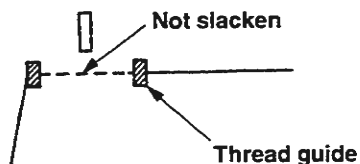

When the spreader moved to the extreme left position, it should be positioned that the top cover thread does not slacken and the spreader does not pull out the thread.

④ Needle thread nipper

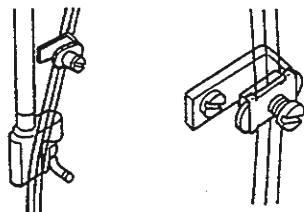

All the needle threads are to be threaded through the needle thread nipper, except the cotton and tetoron type threads.

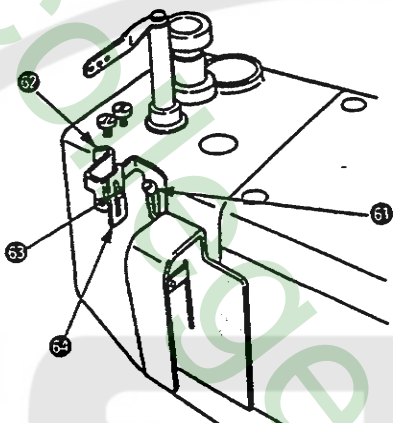
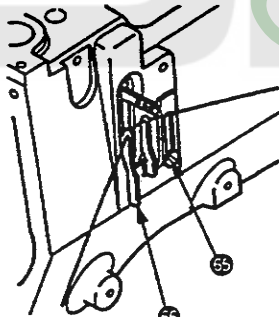
Adjustment Procedures	Results of Improper Adjustment
<ul style="list-style-type: none"> ○ Loosen the screw 58 and fix the thread guide attaching base 60 to the extreme right. Loosen the screw 59 and adjust the respective heights "L" referring to the left table. Make the fine adjustment watching the actual stitching. ○ Loosen screw 61 and adjust by moving the needle thread release 62 up and down. ○ Loosen screw 63 and adjust by moving the right needle thread release 64 up and down.  <ul style="list-style-type: none"> ○ Loosen screw 65 and adjust by moving the thread guide 66 up and down. 	<ul style="list-style-type: none"> ○ If it is raised, the needle thread is tightened. ○ If it is lowered, the needle thread slackens. ○ The tightened stitches of the right needle and left needle can be simply slackened if the thread guide attaching base is moved to the left. ○ If it is raised, the loop of the needle thread becomes large. ○ If it is lowered, the loop of the needle thread becomes small. ○ If the loop is not formed (the loop is too small) and the skip stitching occurs, raise the needle thread release. ○ If the loop is excessively formed, (the loop is too large) and the skip stitching occurs, lower the needle thread release. ○ If it is raised, the thread slackens. ○ If it is lowered, the thread is tightened. ○ Use of the nipper for the threads used Not used for cotton thread and tetoron thread. Used for wooly nylon thread and spun thread (stretching thread). ○ Use of the nipper for the materials used Not used for the light-weight materials of jersey, knit and cloth. Used for the heavy-weight materials of jersey, knit and cloth.

4. OTHER PRECAUTIONS

(1) Points to which Locktite is applied

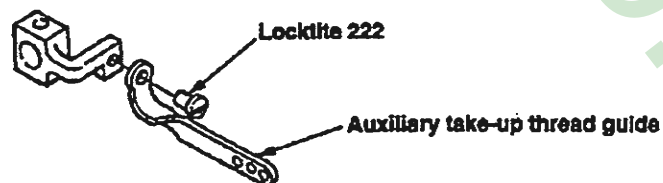

5. TROUBLES AND CORRECTIVE MEASURES

Troubles	Cause (1)	Cause (2)	Corrective measures
1. Thread breakage	Threading	Thread caught in thread guide, incorrect threading	Refer to threading diagram.
	Thread path	Resistance produced by flaw, burr, rust etc. around needle entry of throat plate, stitch tongue, looper, spreader, needle thread take-up nipper, needle guide, thread tension disc etc.	Remove the flaw, burr etc. and polish the thread guide finish. However, replace such important parts as looper or throat plate etc. with the new part because their shape is changed by being polished
	Needle guard	Strong contact of needle against needle guard produces a sharp edge in needle guard resulting in thread breakage.	In case needle holder or looper needle guard is worn out, replace it with the new part.
	Needle	Too thin needle for the thread used	Replace it with an appropriate needle.
	Needle heat	Needle is heated depending on fabric type, number of fabrics, sewing speed resulting in thread breakage.	Use thinner needle. Reduce the sewing speed. Use silicon oil lubricant device.
	Thread	Poor quality and weakness of thread	Replace it with the thread of good quality.
	Thread tension	Too strong thread tension	Reduce thread tension. Adjustable thread guide is positioned too high making the thread tension too strong.
	Interference	Interference with feed dog, throat plate due to the incorrect mounting height of looper	Mount it in the correct position.
	Chain-off thread defect	Flaw produced in stitch tongue in throat plate, feed dog, tongue in presser foot, underside in presser foot	Remove the flaw, burr etc.
2. Looper thread breakage	Thread guide	Resistance produced by flaw, burr, rust etc. in stitch tongue in throat plate, looper, looper thread cam, thread guide, thread tension disc	Remove the flaw, burr etc. and polish the thread guide finish. However, replace such parts as looper with the new part because its shape is changed by being polished
	Looper thread cam adjustment	Excessive tension applied due to the incorrect position of looper thread cam timing, thread guide	Refer to standard adjustment.
	Thread tension	Too strong tension of looper thread	Reduce the thread tension while checking to see the tension balance against the needle thread, top covering thread.

To the next page

Troubles	Cause (1)	Cause (2)	Corrective measures
From the previous page	<p>Thread</p> <p>Looper avoid</p> <p>Needle heat</p>	<p>Poor quality and weakness of thread</p> <p>Too strong contact of looper back with needle resulting in thread breakage</p> <p>In case needle heat is generated looper thread's contact with needle causes thread breakage, specially at the time machine is at rest.</p>	<p>Replace it with good quality of thread.</p> <p>Adjust moving amount, front and rear of looper so that looper contacts the needle at 2/3 height of top of the back.</p> <p>Refer to needle heat in needle breakage</p>
3. Needle breakage	<p>Needle entry</p> <p>Spreader</p> <p>Interference of looper with scooping movement of needle</p> <p>Needle guard</p> <p>Needle thickness No.</p> <p>Thread tension</p> <p>Feed height, Needle height</p>	<p>Needle hits the throat plate or presser foot because the needle entry is not correctly positioned for the plate or foot.</p> <p>Too little clearance between spreader and needle</p> <p>Needle hits looper resulting in needle breakage.</p> <p>Too strong contact against needle guard or needle point hits needle guard due to incorrect position.</p> <p>Too thin needle for fabric used</p> <p>Needle thread tension is too strong.</p> <p>Feed dog is too high or needle height is too low resulting in needle breakage due to needle feed</p>	<p>Align the needle entry to the needle.</p> <p>Refer to standard adjustment</p> <p>Make adjustment so that looper does not hit the looper. For the correction of the contact at looper's back, adjust the moving amount, front and rear.</p> <p>Refer to standard adjustment</p> <p>Use thicker needle.</p> <p>Reduce the needle thread tension.</p> <p>Refer to standard adjustment value.</p>
4. Worn out needle point	<p>Needle guard</p> <p>Interference with looper</p>	<p>Incorrect height or incorrect position, front and rear</p> <p>Moving amount, front and rear is ill balanced.</p>	<p>Check to see the height of needle guard and clearance between needle guard and needle.</p> <p>Adjust moving amount, front and rear and correct the incorrect position of looper's back and the contact when it returns.</p>

Troubles(1)	Troubles(2)	Cause (1)	Cause (2)	Corrective measures
Stitch skipping	<p>Looper does not scoop the right needle thread.</p>  <p>Left Right Left Right</p>	<p>Looper</p> <p>Needle</p> <p>Nipper</p> <p>Adjustable thread guide</p> <p>Needle height</p> <p>Threading</p> <p>Needle guard</p> <p>Spreader</p> <p>Needle heat</p> <p>Looper adjustment</p> <p>Needle guard, front and rear</p>	<p>Incorrect shape of pointed end of looper disables scooping a loop.</p> <p>Needle bent, incorrect needle mounting direction, wrong needle</p> <p>Not used.</p> <p>Too high</p> <p>Needle bar position is too high.</p> <p>Incorrect threading</p> <p>Not used.</p> <p>Spreader thread tension is too strong.</p> <p>Stitch skip occurs before thread breakage produced by needle heat.</p> <p>Incorrect clearance adjustment, incorrect returning amount adjustment</p> <p>Incorrect contact amount, incorrect height</p>	<p>Replace it with the genuine part.</p> <p>Replace the needle with new one, Correct the mounting direction, Use UY121GJS CS100, UY128 GBS FS300.</p> <p>Use nipper.</p> <p>Correct the height to appropriate height.</p> <p>Refer to standard adjustment.</p> <p>Refer to threading diagram.</p> <p>Use needle guard.</p> <p>Reduce the tension.</p> <p>Same described in page " Thread breakage by needle heat"</p> <p>Refer to standard adjustment.</p> <p>Refer to standard adjustment.</p>
	<p>Looper does not scoop the middle needle thread.</p>  <p>Left Right Left Right</p>	<p>Looper</p> <p>Needle</p> <p>Nipper</p> <p>Adjustable thread guide</p> <p>Needle height</p> <p>Threading</p>	<p>Incorrect shape of pointed end of looper disables scooping a loop.</p> <p>Needle bent, incorrect needle mounting direction, wrong needle</p> <p>Being used.</p> <p>Height is too low.</p> <p>Needle bar height is too low.</p> <p>Incorrect threading.</p>	<p>Replace it with the genuine part.</p> <p>Replace the needle with new one, Correct the mounting direction, Use UY121GJS CS100, UY128 GBS FS300</p> <p>Do not use nipper.</p> <p>Correct height position to appropriate height.</p> <p>Refer to standard adjustment.</p> <p>Refer to threading diagram.</p>

To the next page

To the next page



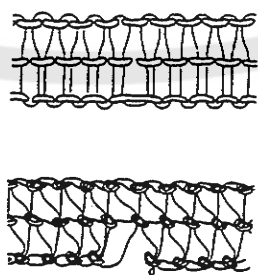

Troubles(1)	Troubles(2)	Cause (1)	Cause (2)	Corrective measures
From the previous page	From the previous page	Needle thread guard	Being used.	Do not use.
		Spreader	Spreader thread tension is too strong.	Reduce the tension.
		Needle heat	Stitch skip occurs before thread breakage produced by needle heat.	Same described in page "Thread breakage by needle heat"
		Looper adjustment	Incorrect clearance adjustment, incorrect returning amount adjustment	Refer to standard adjustment.
		Needle guard, front and rear	Incorrect contact amount, incorrect height	Refer to standard adjustment.
		Looper	Incorrect shape of pointed end of looper disables scooping a loop.	Replace it with the genuine part.
		Needle	Needle bend, incorrect needle mounting direction, wrong needle	Replace the needle with new one. Correct the mounting direction. Use UY121GJS CS100, UY128 GBS FS300.
		Nipper	Being used.	Do not use nipper.
		Intermediate thread guide	Height is too low.	Correct height position to appropriate height.
		Needle height	Height is too low.	Refer to standard adjustment.
		Threading	Incorrect threading	Refer to threading diagram.
		Needle guard	Being used.	Do not use.
		Spreader	Too near to the left needle	Refer to standard adjustment.
		Needle heat	Stitch skip occurs before thread breakage produced by needle heat.	Same described in page "Thread breakage by needle heat"
		Looper adjustment	Incorrect clearance adjustment, incorrect returning amount	Refer to standard adjustment.
		Needle guard, front and rear	Incorrect contact amount, incorrect height	Refer to standard adjustment.

Looper does not scoop the left needle thread.

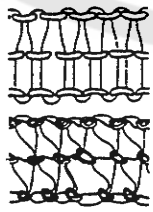

Left Right Left Right

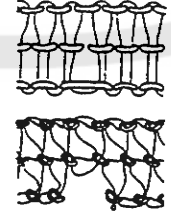
To the next page

Troubles(1)	Troubles(2)	Cause (1)	Cause (2)	Corrective measures
From the previous page	<p>Needle does not scoop the looper thread. (Triangle stitch skip) Middle needle Left needle</p> 	Looper	shape is incorrect.	Replace it with the genuine part.
Stitch skip by middle needle		Needle	Needle bent	Replace the needle with the new one.
Slack of looper thread		Needle height	Needle bar position is too high.	Refer to standard adjustment.
Stitch skip by left needle		Threading	Incorrect threading	Refer to threading diagram.
Slack of looper thread		Looper adjustment	Incorrect clearance adjustment, incorrect returning amount	Refer to standard adjustment.
		Looper thread tension	Tension is too weak.	Increase tension.
		Looper thread cam timing	Looper thread cam timing is too fast.	Refer to standard adjustment.

Troubles(1)	Troubles(2)	Cause (1)	Cause (2)	Corrective measures
	From the previous page			
	Skipping in top cover stitch (right)	Spreader	Incorrect shape of pointed end of spreader disables scooping a thread.	Replace it with the genuine part.
		Needle	Needle bent, wrong needle	Replace the needle with the new one, Use UY121GJS CS100, UY128 GBS FS300.
		Spreader adjustment	Incorrect height, protruding amount, position, front and rear	Refer to standard adjustment.
		Stationary spreader thread guide	Incorrect height, position	Refer to standard adjustment.
		Needle height	Needle bar position is too low.	Refer to standard adjustment.
		Threading	Incorrect threading	Refer to threading diagram.
		Needle holder spreader thread guide	Incorrect height, position, front and rear	Refer to standard adjustment.
		Spreader thread tension	Spreader thread tension is too weak.	Increase tension.
		Spreader take-up thread drawing-in amount	Incorrect drawing-in amount of thread	Refer to standard adjustment.

Skipping in top covering stitch by right needle

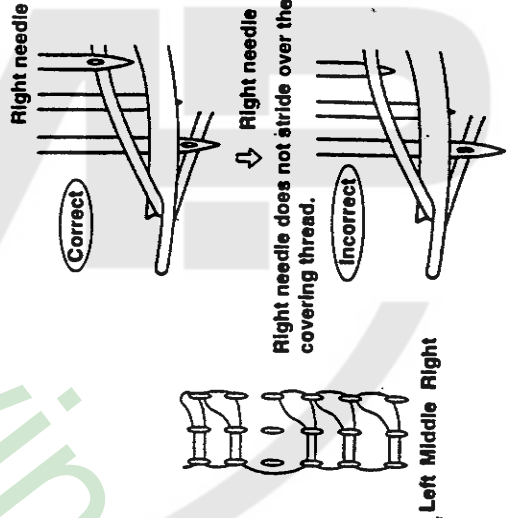

Skipping in top covering stitch by right needle
Simultaneous skip by left and middle needle

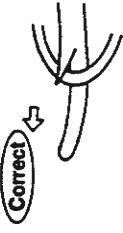

Spreader does not fetch the top covering thread.

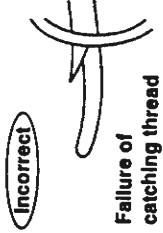

Failure of catching thread



Left Middle Right

To the next page

Troubles(1)	Troubles(2)	Cause (1)	Cause (2)	Corrective measures
From the previous page	Skipping in top covering stitch (Middle)	Needle Spreader adjustment Needle height Threading Spreader thread tension Spreader pull-off Stationary spreader thread guide	Needle bent, wrong needle Incorrect height, protruding amount, position, front and rear Incorrect needle bar position Incorrect threading Spreader thread tension is too weak. Incorrect drawing-in amount of thread Incorrect height and position	Replace the needle with the new one, Use UY121GJS CS100, UY128GBS FS300. Refer to standard adjustment. Refer to standard adjustment. Refer to threading diagram. Increase tension. Refer to standard adjustment. Refer to standard adjustment.



Left Middle Right

Skipping in top covering stitch by middle needle
 Middle needle does not scoop top covering thread.

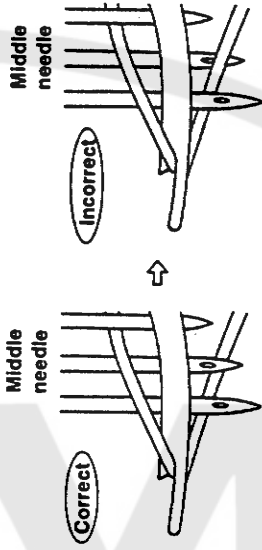

Middle needle strides over top covering thread, sometimes.

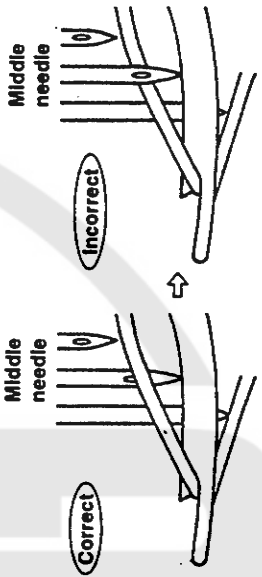

Troubles(1)	Troubles(2)	Cause (1)	Cause (2)	Corrective measures
From the previous page	Skipping in top covering stitch (Left)	Spreader	Incorrect shape of pointed end disables scooping a thread.	Replace it with the genuine part.
		Needle	Needle bent, wrong needle	Replace needle with new one, Use UY121GJS CS100, UY128GBS FS300.
		Spreader adjustment	Incorrect height, protruding amount, position, front and rear	Refer to standard adjustment.
		Stationary spreader thread guide	Incorrect height and position	Refer to standard adjustment.
		Needle height	Needle bar position is too low.	Refer to standard adjustment.
		Threading	Incorrect threading	Refer to threading diagram.
		Spreader thread tension	Spreader tension is too weak.	Increase tension.
		Spreader pull-off drawing-in amount of thread	Incorrect drawing-in amount of thread	Refer to standard adjustment.

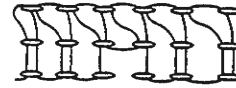

Skipping in top covering stitch by left needle
Left needle does not scoop top covering thread.

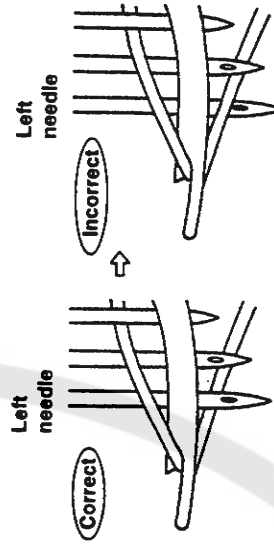

Troubles(1)	Troubles(2)	Cause (1)	Cause (2)	Corrective measures
	From the previous page			
	Single chain thread cast-off (Right, Middle, Left)	Needle	Needle bent, wrong needle	Replace the needle with the new one, Use UY121GJS CS100, UY128GBS FS300.
		Needle height	Needle bar position is too high.	Refer to standard adjustment.
		Threading	Incorrect threading	Refer to threading diagram.
		Throat plate	R of slitch tongue in throat plate is too small. 	Increase R. Polish correctly.
		Looper	Incorrect polishing	
			R of looper's body section is too large and ridgeline is not straight for which needle thread is likely to slip from looper.	Replace it with the genuine part.
		Looper adjustment	Too little contact amount between looper's back and needle	Refer to standard adjustment.
		Thread tension	Thread tension is too weak.	Increase tension.
		Adjustable , thread guide position	Low position of thread guard results in too large needle thread loop.	Lift thread guide position.
		Thread guard position	Thread guard position is too high.	Refer to standard adjustment.
		Nipper	Use of nipper could easily generate this trouble.	Do not use nipper.
		Looper thread cam thread guide position	Drawing-in amount of looper thread is too much.	Reduce drawing-in amount of thread.

From the previous page

101 stitch by right needle

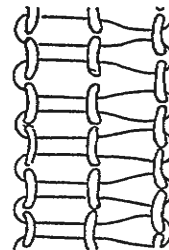
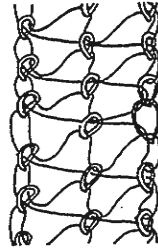
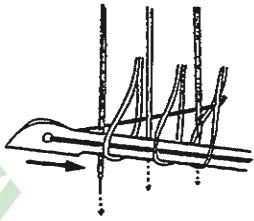

101 stitch by middle needle

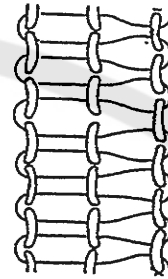
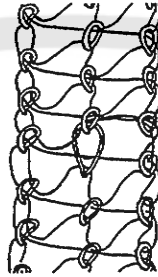

101 stitch by left needle

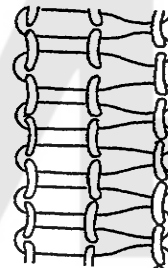
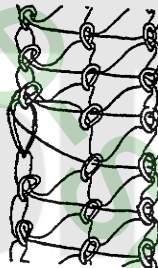
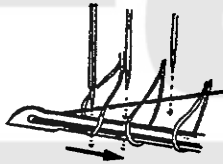

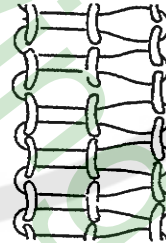
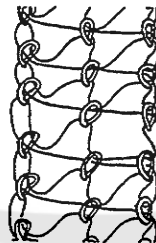
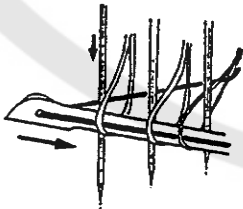

Right needle thread miss

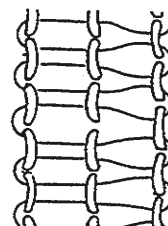
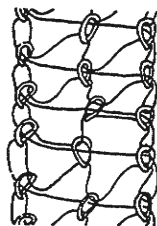
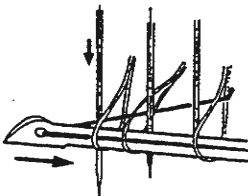

Middle needle thread miss

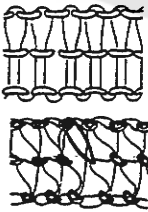
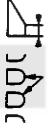
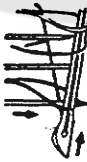
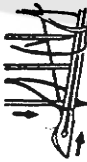
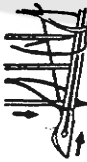
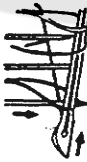
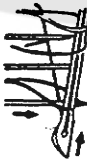
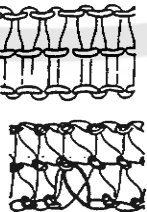

Troubles(1)	Troubles(2)	Cause (1)	Cause (2)	Corrective measures
From the previous page	<p>Double bonding stitch (Middle, Left)</p> 	Throat plate	<p>R of stitch tongue in throat plate is too large. Stitch tongue is too short.</p>  <p>R Length of stitch tongue</p>	Replace it with the genuine part.
	<p>Right needle enters middle needle loop.</p> 	Needle	Worn out needle point, needle bent, wrong needle	Replace needle with new one, Use UY121GJS CS100, UY128GBS FS300.
	<p>Right needle enters middle needle loop.</p> 	Looper	Flaw in looper's body section, incorrect polishing	Replace the looper when modified or its shape is changed too much.
	<p>Right needle enters middle needle loop.</p> 	Needle height	Needle bar position is too low.	Refer to standard adjustment.
	<p>Right needle enters middle needle loop.</p> 	Threading	Incorrect threading	Refer to threading diagram.
	<p>Right needle enters middle needle loop.</p> 	Needle thread tension	Tension is too weak.	Increase tension.
	<p>Middle needle enters left needle loop.</p> 	Adjustable thread guide position	Thread guide position is too low.	Lift the thread.
	<p>Middle needle enters left needle loop.</p> 	Nipper	Use of nipper is likely to generate this trouble.	Do not use nipper.

Troubles(1)	Troubles(2)	Cause (1)	Cause (2)	Corrective measures		
From the previous page	Irregular stitches (Left, Middle, Right)	Throat plate	Incorrect polishing	Polish correctly.		
		Spreader adjustment	Stroke of spreader is too large.	Refer to standard adjustment.		
		Looper	Worn out looper's pointed end and incorrect polishing	Replace the looper when modified or its shape is changed too much.		
		Top covering thread take-up	Drawing-in amount of top covering thread is too much.	Refer to standard adjustment.		
		Needle thread tension	Needle thread tension is too weak.	Increase tension.		
		Threading	Incorrect threading	Refer to threading diagram.		
		Top covering thread tension	Thread tension is too weak.	Increase tension.		
		Looper thread cam thread guide position	Drawing-in amount of looper thread is too much.	Reduce drawing-in amount of thread.		
		To the next page	Ill-tensed seam	Throat plate	Incorrect polishing, Too long stitch tongue	Correct or replace part.
				Needle	Worn out needle point, needle bent, wrong needle	Replace needle with new one, Use UY121GJS CS100, UY128GBS FS300.
				Looper	Worn out looper's pointed end, incorrect polishing	Replace the looper when modified or its shape is changed too much.
				Needle height	Needle bar position is too low.	Refer to standard adjustment.
				Threading	Incorrect threading	Refer to threading diagram.
Needle thread tension	Tension is too weak.			Increase tension.		
Adjustable thread guide position	Thread guide position is too low.			Lift the position		
Looper thread tension	Tension is too strong.			Reduce tension.		
Looper thread cam thread guide position	Drawing-in amount of looper thread is too little.			Increase drawing-in amount of thread.		



Troubles(1)	Troubles(2)	Cause (1)	Cause (2)	Corrective measures
From the previous page	Defective chain-off thread (with top covering stitch)	Throat plate	Thread threading is not smooth due to incorrect polishing in stitch tongue.	Replace when polished or its shape is changed too much.
		Spreader adjustment	Stitch skip in top covering stitch due to incorrect adjustment	Refer to standard adjustment.
		Looper adjustment	Stitch skip due to incorrect adjustment	Refer to standard adjustment.
		Top covering thread take-up	Drawing-in amount of top covering thread is too much or too little.	Refer to standard adjustment.
		Needle thread tension	Needle thread tension is too weak.	Increase tension.
		Threading	Incorrect threading	Refer to threading diagram.
		Top covering thread tension	1st thread tension is too weak.	Increase tension.
		Stitch tongue of presser foot	Thread threading is not smooth due to incorrect shape of stitch tongue.	Replace when its shape is modified or changed too much.
		Needle	Worn out needle point, needle bent, wrong needle	Replace needle with new one, Use UY121GJS CS100, UY128GBS FS300.
		Feed dog	Flaw on surface in feed dog	Modify or replace.
	Stitch skip & stitch missing at start of sewing after thread trimming (thread trimmer sewing machine, bottom covering stitch)	Double cutting	Remaining thread is too short by double cutting.	Refer to standard adjustment.
		Looper thread clamp	Clamping force is too weak.	Increase clamping force.
		Pulling-in of thread	Pulling-in amount of thread is too little at time of thread trimming.	Increase pulling-in amount.
		Mechanical wiper	Clamping force is too weak.	Increase clamping force.
		Pneumatic wiper	Needle is entangled with thread by incorrect direction of air blow outlet.	Correct direction so that remaining thread flows to presser bar side.
		Presser foot	Falling speed of presser is too slow in automatic lifter.	Increase falling speed. (to get rid of shaky movement etc.)

To the next page



NOTES

www.collegesewing.co.uk

ESMA

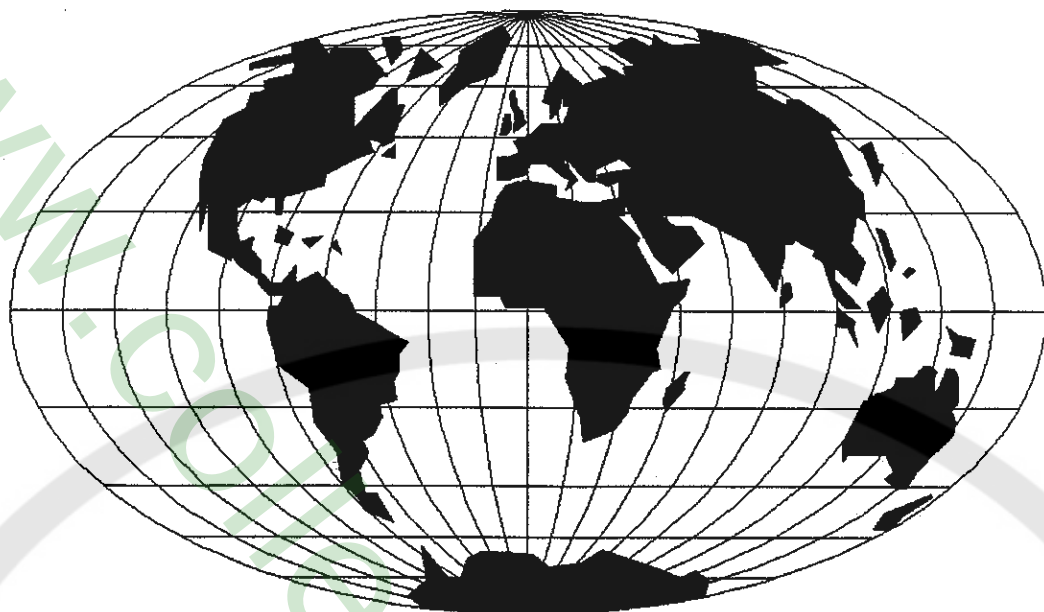

WORLDWIDE SALES AND SERVICE

Union Special Corporation maintains sales and service facilities throughout the world. These offices will aid you in the selection of the right sewing equipment for your particular operation. Union Special Corporation representatives and service technicians are factory trained and are able to serve your needs promptly and efficiently. Whatever your location, there is a qualified representative to serve you.

Brussels, Belgium
Charlotte, N.C.
El Paso, TX
Hong Kong, China
Huntley, IL
Leicester, England
Lille, France
Miami, FL
Milan, Italy
Möglingen, Germany
Montreal, Quebec
Osaka, Japan
Santa Fe Springs, CA

Other Representatives throughout
all parts of the world.



Union Special
INDUSTRIAL SEWING EQUIPMENT