



Union Special[®]
INDUSTRIAL SEWING EQUIPMENT

CATALOG NO.103UG-GR

STYLES

39500UG

39500UM

THREADING DIAGRAM AND ILLUSTRATED
PARTS LIST

FIRST EDITION





FIRST EDITION

© 2006

PRINTED 2006 IN USA

INFORMATION SUBJECT TO CHANGE WITHOUT NOTICE

© UNION SPECIAL CORPORATION ALL RIGHTS RESERVED IN ALL COUNTRIES.

39500 UG-1/8 THREADING DIAGRAM

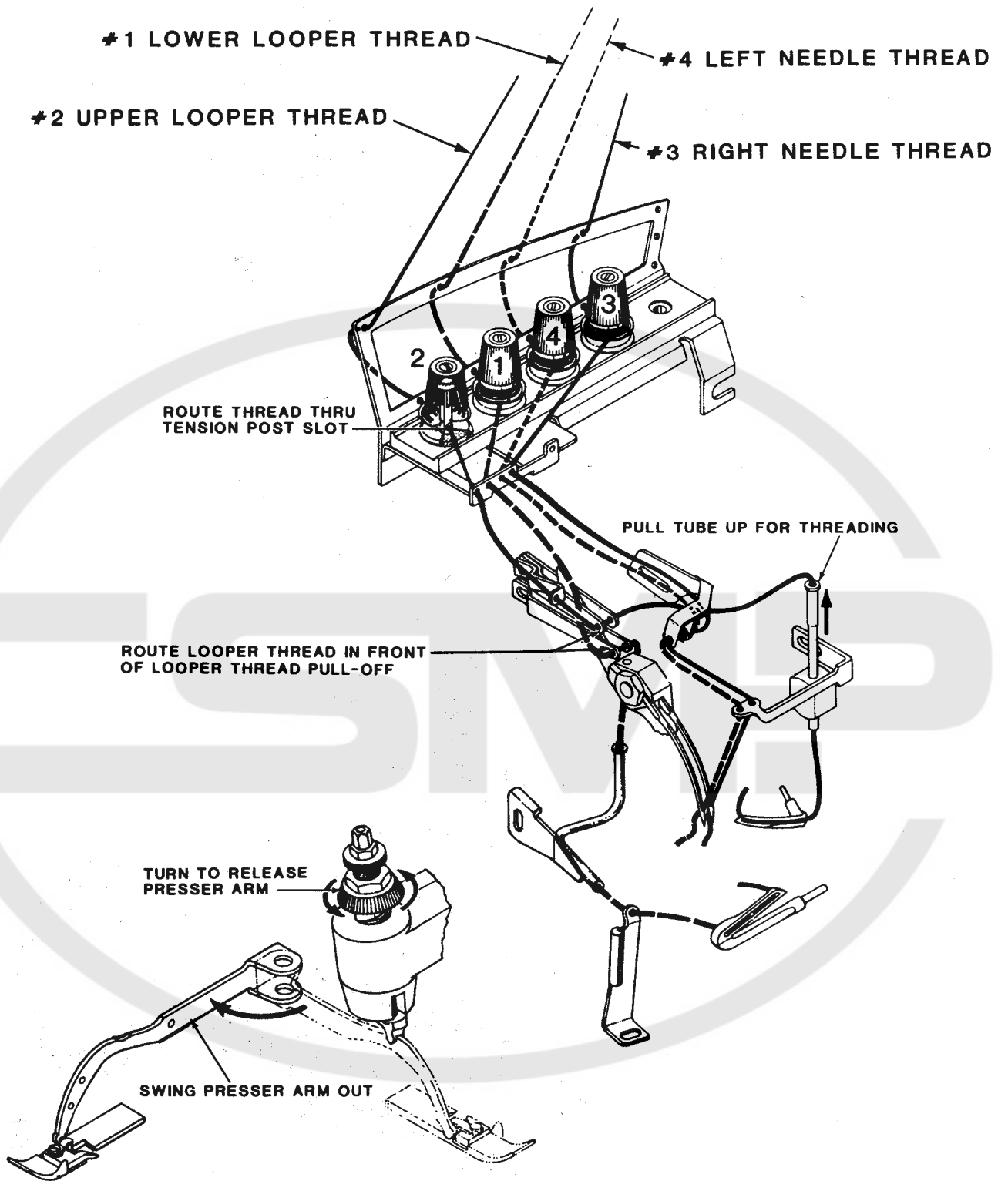

Thread machine in sequence as shown: (1) lower looper thread, (2) upper looper thread, (3) right needle thread and (4) left needle thread.

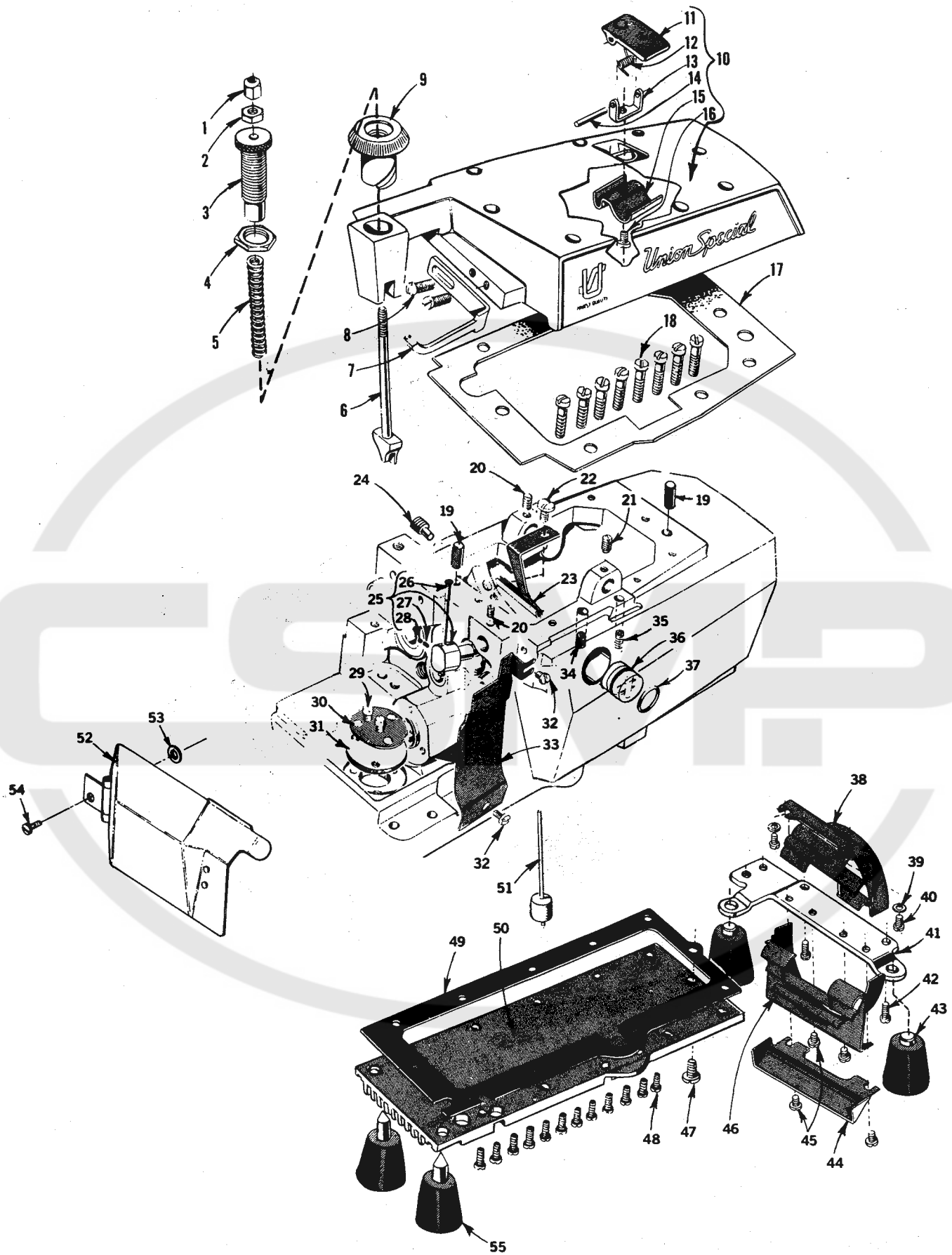

MAIN FRAME, PRESSER FOOT RELEASE PARTS,
MISCELLANEOUS COVERS AND PLATES

Ref. No.	Part No.	Description	Amt. Req.
1	39557 B	Presser Spring Plunger Cap Nut -----	1
2	39557 E	Presser Spring Plunger Locking Nut -----	1
3	39557 C	Presser Spring Plunger Adjusting Screw -----	1
4	39557 F	Lock Nut, for adjusting screw -----	1
5	39557	Presser Spring -----	1
6	39557 A	Presser Spring Plunger -----	1
7	39563 X	Top Cover Needle Thread Eyelet -----	1
8	22569 B	Screw, for top cover needle thread eyelet -----	2
9	39556 A	Presser Foot Release Bushing -----	1
10	39582 DK	Top Cover -----	1
11	39582 AF	Oil Filler Cover -----	1
12	39582 V	Spring -----	1
13	39582 AG	Hinge Bracket -----	1
14	51-103 Blk.	Hinge Pin -----	1
15	39582 W	Oil Guard -----	1
16	22562 A	Screw, for hinge bracket -----	1
17	39582 BZ	Top Cover Gasket -----	1
18	22541	Screw, for top cover -----	8
19	667 D-8	Dowel Pin -----	2
20	22565	Set Screw, for upper looper thread tube assembly and for upper looper drive lever shaft -----	2
21	22565 S	Spot Screw, for upper looper drive lever shaft -----	1
22	22569 D	Screw, for oil collector plate -----	1
23	39594 R	Oil collector Plate -----	1
24	22571 E	Magnetic Oil Drain Plug Screw -----	1
25	29477 GW	Upper Looper Thread Tube Assembly -----	1
26	39568 G	Thread Tube -----	1
27	39568 J	Thread Tube Tension Spring -----	1
28	22743	Set Screw, for thread tube tension spring -----	1
29	22760 H	Screw, for oil filter screen and strainer -----	2
30	39594 G	Oil Filter Screen -----	1
31	39594 H	Oil strainer, felt -----	1
32	22569 D	Screw, for chip guard -----	2
33	G39578 U	Chip Guard -----	1
34	22569 K	Screw, for oil sight gauge -----	1
35	22894 AE	Screw, for lower looper bar driving lever shaft -----	2
36	39593 H	Oil Sight Gauge -----	1
37	660-243	Oil Gauge Seal Ring -----	1
38	39582 BV	Air Duct, upper -----	1
39	8372 A	Washer, for upper air duct -----	2
40	22569 C	Screw, for upper air duct -----	2
41	39582 BM	Base Plate -----	1
42	22541 B	Screw, for base plate -----	2
43	39595	Isolator -----	2
44	39582 BL	Air Duct, outer -----	1
45	22569 D	Screw, for lower and outer air duct -----	4
46	39582 BK	Air Duct lower -----	1
47	22586 T	Screw, for bottom cover -----	1
48	22541 B	Screw, for bottom cover -----	12
49	39582 BH	Bottom Cover Gasket -----	1
50	39582 DH	Bottom Cover -----	1
51	39593 M	Oil Gauge Indicator Assembly -----	1
52	39582 DN	Feed Bar Cover Assembly -----	1
53	39198 D	Washer -----	1
54	22758 C	Screw -----	1
55	51295 B	Isolator -----	2

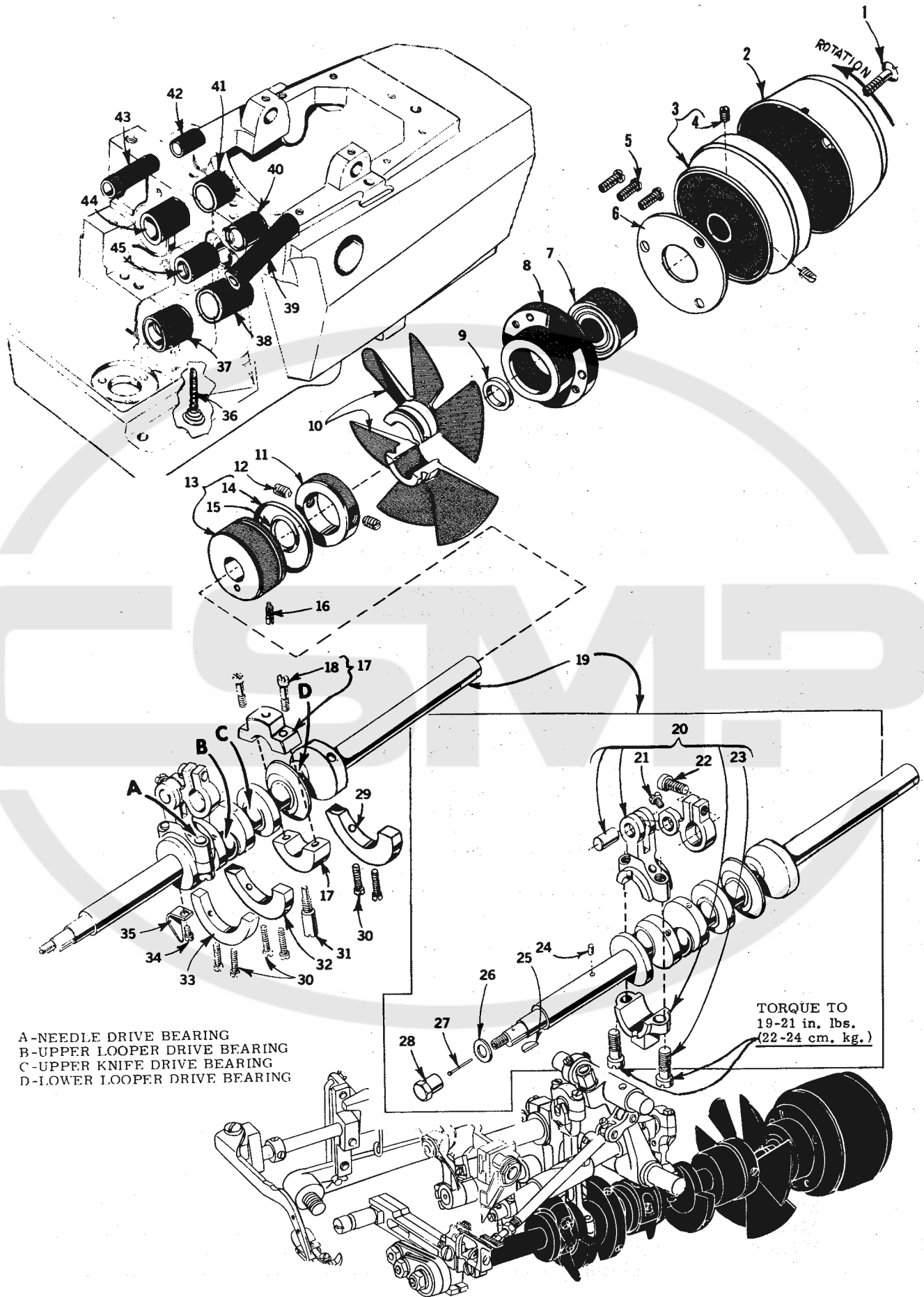

CRANKSHAFT MECHANISM AND BUSHINGS

<u>Ref. No.</u>	<u>Part No.</u>	<u>Description</u>	<u>Amt. Req.</u>
1	22769 B	Screw, for pulley cap -----	1
2	39521 D	Pulley Cap -----	1
3	39521 G	Pulley -----	1
4	95	Screw, for pulley -----	2
5	22569 Y	Screw, for crankshaft ball bearing retaining plate -	3
6	39590 H	Crankshaft Ball Bearing Retaining plate -----	1
7	660-835	Crankshaft Ball Bearing -----	1
8	39590 G	Crankshaft Ball Bearing Housing -----	1
9	39590 J	Thrust Washer -----	1
10	39591 L	Crank Chamber Cooling Fan -----	1
11	39591 H	Crank Chamber Cooling Fan Collar -----	1
12	22894 D	Spot Screw, for crank chamber cooling fan collar ---	2
13	39590 Y	Crankshaft Bearing, inner right -----	1
14	660-443	"O" Ring, for crankshaft bearing, inner right -	1
15	660-764	Oil Seal -----	1
16	22565 F	Screw, for crankshaft bearing, inner right -----	1
17	39590 D	Crankshaft Split Bearing -----	1
18	97 A	Screw, for crankshaft split bearing -----	2
19	29477 JM	Crankshaft and Needle Driving Arm Crank Assembly ---	1
20	29477 MC	Needle Driving Arm Crank and Connecting Rod Assembly -----	1
21	22768 C	Screw, for needle driving arm connecting rod pin -----	1
22	22596 H	Screw, for needle driving arm crank -----	1
23	22587 M	Screw, for needle driving arm connecting rod -----	2
24	51-228 Blk.	Vent Plug -----	1
25	39541 A	Feed Driving Eccentric Key -----	1
26	40-46	Washer -----	1
27	39593 U-126	Metering Pin, Marked "B" -----	1
28	39536 FN	Nut, for crankshaft -----	1
29	39591 B	Crankshaft Counterweight, right -----	1
30	22747 B	Screw, for crankshaft counterweights -----	6
31	39590 N	Stud, for crankshaft split bearing -----	1
32	39591 A	Crankshaft Counterweight, middle -----	1
33	39591 K	Crankshaft Counterweight, left -----	1
34	87 U	Screw, for oil Splasher -----	1
35	39594 N	Oil Splasher -----	1
36	666-94	Oil Wick and Spring -----	1
37	39590	Crankshaft Bushing, left -----	1
38	39590 T	Crankshaft Bushing, inner left -----	1
39	39544 X	Lower Looper Bar Bushing -----	1
40	39552 Z	Needle Driving Arm Crank Bushing, right -----	1
41	39573 AA	Upper Knife Driving Arm Bushing, right -----	1
42	39555 N	Foot Lifter Shaft Bushing, right -----	1
43	39555 P	Foot Lifter Shaft Bushing, left -----	1
44	39573 K	Upper Knife Driving Arm Crank Bushing, left -----	1
45	39552 AL	Needle Driving Arm Crank Bushing, left -----	1

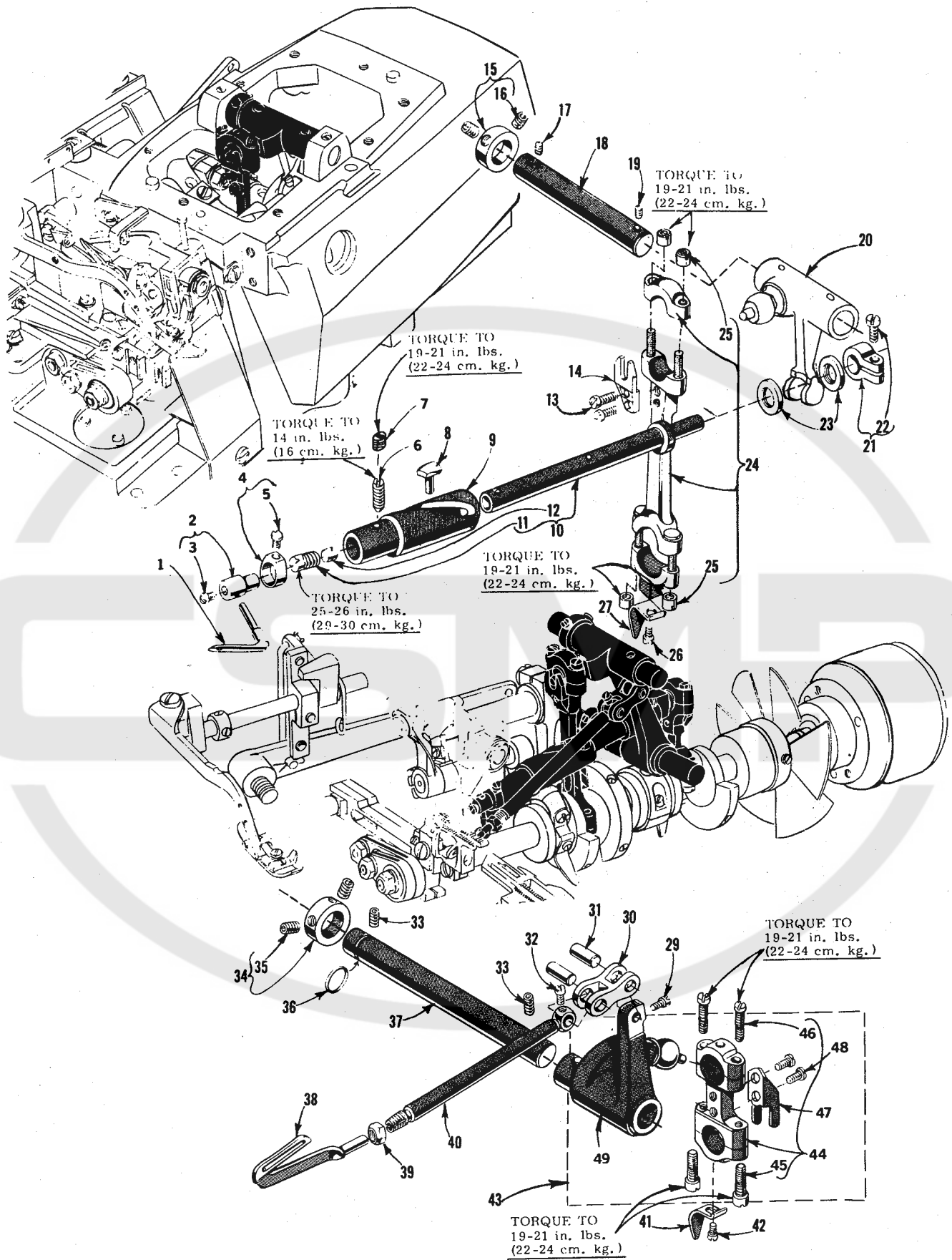

UPPER AND LOWER LOOPER DRIVING PARTS

<u>Ref. No.</u>	<u>Part No.</u>	<u>Description</u>	<u>Amt. Req.</u>
1	39508 A	Upper Looper, marked "CC" -----	1
2	39543	Upper Looper Holder -----	1
3	22564 G	Screw, for upper looper -----	1
4	39543 A	Upper Looper Holder Collar -----	1
5	77	Screw, for upper looper holder collar -----	1
6	22565 H	Spot Screw, for bushing and cam guide -----	1
7	1025 L	Lock Screw, for bushing and cam guide screw -----	1
8*	39543 T	Cam Follower -----	1
9*	39543 S	Bushing and Cam Guide -----	1
10*	39543 K	Upper Looper Drive Shaft -----	1
11	22503 F	Screw, for cam follower locking clamp -----	1
12	39543 E	Cam Follower Locking Clamp -----	1
13	97	Screw, for ball joint guide fork -----	2
14	39544 J	Ball Joint Guide Fork, for upper looper drive lever --	1
15	482 C	Upper Looper Shaft Collar -----	1
16	22894 C	Set Screw, for upper looper shaft collar -----	2
17	22565	Set Screw, for upper looper rock shaft -----	1
18	39543 X	Upper Looper Drive Lever Shaft -----	1
19	22565 S	Spot Screw, for upper looper drive lever shaft -----	1
20	39543 W	Upper Looper Drive Lever -----	1
21	39543 AJ	Clamp Collar, for upper looper drive shaft -----	1
22	22875 L	Screw, for clamp collar -----	1
23	39543 P	Upper Looper Drive Shaft Thrust Washer -----	2
24	39543 AK	Upper Looper Drive Lever Connecting Rod -----	1
25	39543 AF	Nut, barrel -----	4
26	87 U	Screw, for oil splasher -----	1
27	39594 N	Oil Splasher -----	1
29	77	Screw, for lower looper bar connecting link pin -----	1
30	39544 B	Lower Looper Bar Connecting Link -----	1
31	39544 D	Lower Looper Bar Connecting Link Pin -----	2
32	77	Screw, for lower looper bar connecting link pin -----	1
33	22894 AE	Set Screw, for lower looper driving shaft -----	2
34	482 C	Lower Looper Driving Shaft Collar -----	1
35	22894 C	Set Screw, for lower looper driving shaft collar -----	2
36	660-206	"O" Ring, for lower looper driving shaft -----	1
37	39544 V	Lower Looper Driving Shaft -----	1
38	39508 P	Lower Looper -----	1
39	39151	Nut, for lower looper bar -----	1
40	39544	Lower Looper Bar -----	1
41	39594 N	Oil Splasher -----	1
42	87 U	Screw, for oil splasher -----	1
43	29126 DF	Lower Looper Bar Driving Lever and Connecting Rod Assembly -----	1
44	39544 N	Lower Looper Drive Lever Connecting Rod -----	1
45	22729 E	Screw, for connecting Rod -----	2
46	22729 D	Screw, for connecting rod -----	2
47	39544 S	Ball Joint Guide Fork -----	1
48	97	Screw, for ball joint guide fork -----	2
49	39544 U	Lower Looper Bar Driving Lever -----	1

* The use of assembly No. 29126 EC is recommended instead of the individual parts.

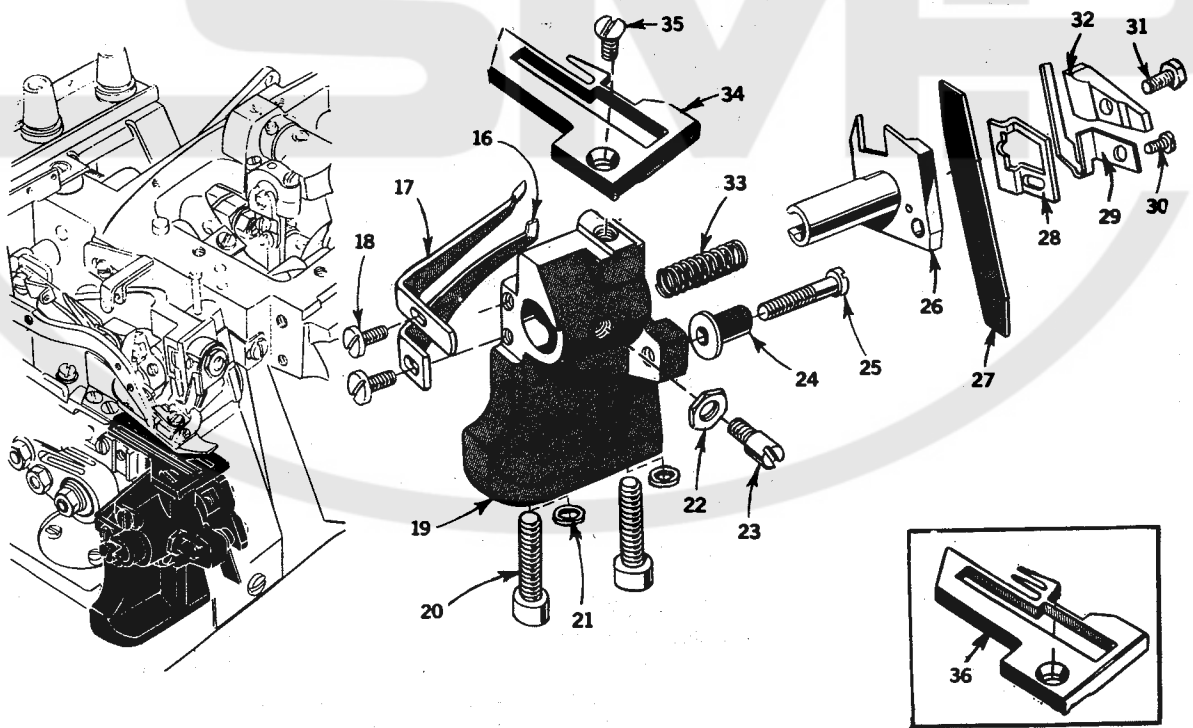
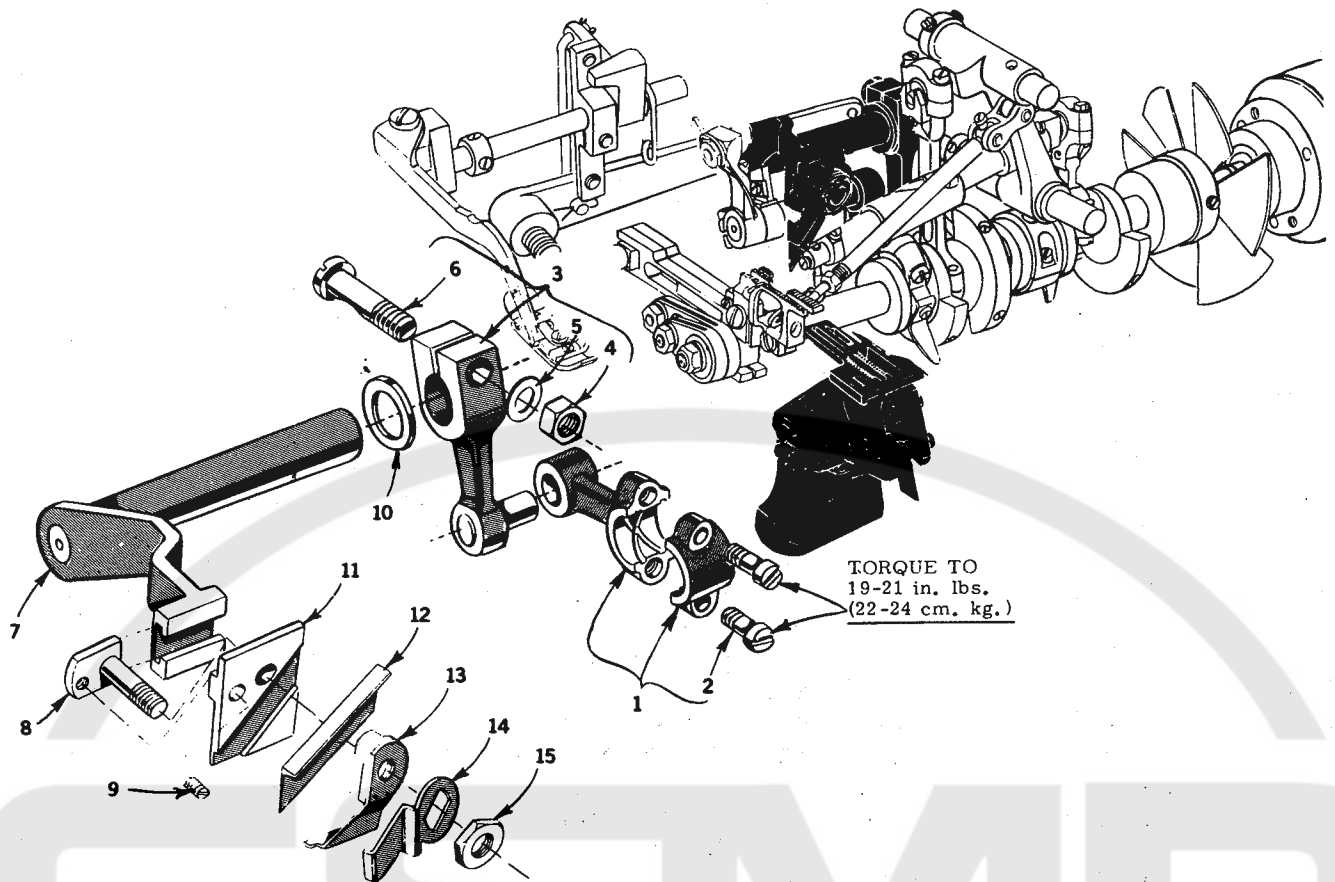

UPPER AND LOWER KNIFE

<u>Ref. No.</u>	<u>Part No.</u>	<u>Description</u>	<u>Amt. Req.</u>
1	39573 AD	Upper Knife Driving Connecting Rod -----	1
2	22587 J	Screw, for upper knife driving connection rod -	2
3	39573 E	Upper Knife Driving Lever -----	1
4	55235 E	Nut, for upper knife driving lever -----	1
5	6042 A	Washer, for upper knife driving lever -----	1
6	55235 D	Locking Stud, for upper knife driving lever ---	1
7	39573 H	Upper Knife Driving Arm -----	1
8	39571 D	Upper Knife Clamp Stud -----	1
9	22738	Screw, for upper knife clamp stud -----	1
10	39573 A	Upper Knife Driving Arm Washer -----	1
11	39572	Upper Knife Holder Block -----	1
12	39570	Upper Knife -----	1
13	39571 F	Upper Knife Clamp -----	1
14	39571 B	Upper Knife Chain Guard -----	1
15	14077	Nut, for upper knife clamp stud -----	1
16	39525	Needle Guard, front -----	1
17	39525 E	Needle Guard, rear -----	1
18	22585 A	Screw, for needle guards -----	2
19	39580 AJ	Throat Plate and Lower Knife Support Bracket -----	1
20	22653 B-12	Screw, for throat plate and lower knife support bracket -----	2
21	39580 F	Washer, for throat plate and lower knife support bracket -----	2
22	14077	Nut, for lower knife holder locking screw -----	1
23	22892 B	Locking Screw, for lower knife holder -----	1
24	39550 C	Lower Knife Holder Locating Stud -----	1
25	22729 B	Screw, for lower knife holder locking stud -----	1
26	39550 AK	Lower Knife Holder -----	1
27	39549	Lower Knife -----	1
28	39550 AC	Knife Guide Plate -----	1
29	39550 AE	Lower Knife Clamp Spring -----	1
30	605 A	Screw, for lower knife clamp spring -----	1
31	22588 J	Screw, for lower knife clamp -----	1
32	39550 AD	Lower Knife Clamp -----	1
33	39550 E	Lower Knife Holder Spring -----	1
34	C39524 BR	Throat Plate, Marked "LD", for Single Needle Machines -----	1
35	22524	Screw, for throat plate -----	1
36	C39524 BA-1/8	Throat Plate, Marked "EM", for Two Needle Machines -----	1

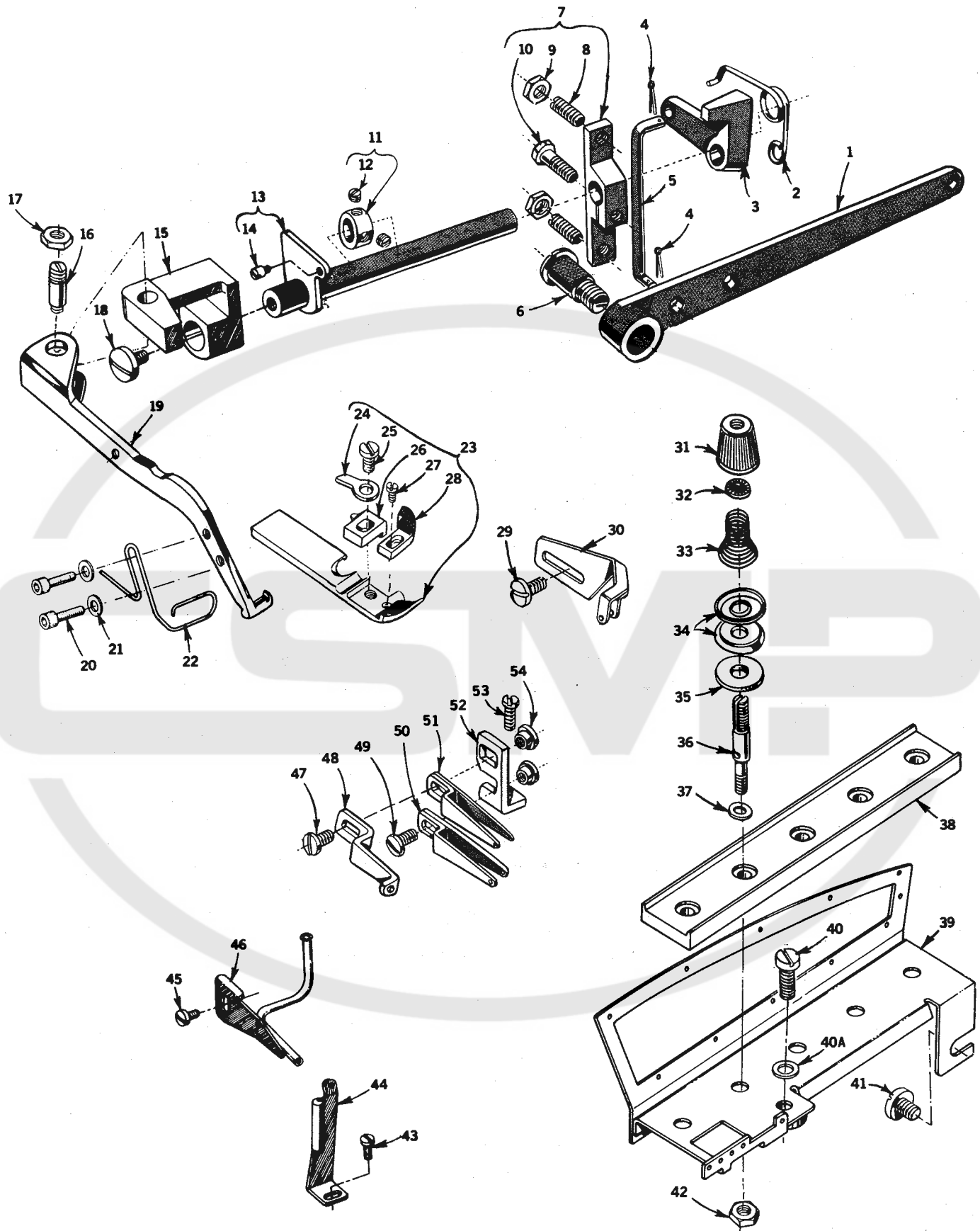

FOOT LIFTER, THREAD TENSION
PARTS AND MISCELLANEOUS EYELETS

Ref. No.	Part No.	Description	Amt. Req.
1	39855	Foot Lifter Lever -----	1
2	39555 B	Foot Lifter Lever Spring -----	1
3	39555 D	Foot Lifter Intermediate Lever -----	1
4	660-142	Cotter Pin, for foot lifter lever connecting link -----	2
5	39555 F	Foot Lifter Lever Connecting Link -----	1
6	22566 B	Screw, for foot lifter lever -----	1
7	39555 C	Foot Lifter Lever Arm -----	1
8	22597 E	Set Screw, for foot lifter lever arm -----	2
9	12538	Lock Nut, for foot lifter lever arm -----	2
10	627	Screw, for foot lifter lever arm -----	1
11	12865	Foot Lifter Lever Shaft Thrust Collar -----	1
12	88	Screw, for foot lifter lever shaft collar -----	2
13	39555 AE	Presser Arm Support Bracket Shaft -----	1
14	22845 B	Screw -----	1
15	39555 AF	Presser Arm Support Bracket -----	1
16	22791 H	Screw Pin, for presser arm -----	1
17	258 A	Nut, for presser arm screw -----	1
18	88 D	Screw -----	1
19	39556 S	Presser Arm -----	1
20	99360	Screw -----	2
21	95956	Washer -----	2
22	99682 L	Finger Guard -----	1
23	39520 BA	Presser Foot -----	1
24	39530 G	Hinge Spring -----	1
25	22768 B	Screw, for stitch tongue and hinge spring -----	1
26	39597 AB	Stitch Tongue, Marked "EK" -----	1
27	22738	Screw, for chip guard -----	1
28	39530 P	Chip Guard -----	1
29	22569 D	Screw -----	1
30	39563 N	Needle Thread Eyelet -----	1
31	39592 Z	Needle Tension Nut, Yellow, Left -----	1
	39592 AA	Needle Tension Nut, Green, right -----	1
	39592 AB	Upper Loper Tension Nut, Blue -----	1
	39592 AC	Lower Loper Tension Nut, Red -----	1
32	39592 AK	Tension Spring Ferrule -----	1
33	39592 AR-5	Needle Thread Tension Spring, left, 2 needle machines -----	1
	39592 AR-4	Needle Thread Tension Spring, right, 2 needle machines -----	1
	39592 AR-1	Looper Thread Tension Spring, 2 needle machines -----	2
	39592 AR-2	Needle Thread Tension Spring, single needle machines -----	1
	39592 AR-4	Looper Thread Tension Spring, single needle machines -----	2
34	39592 AD	Thread Tension Disc -----	6 or 8
35	39592 AF	Tension Disc Felt -----	3 or 4
36	39592 AL	Tension Post -----	3 or 4
37	8372 A	Washer -----	3 or 4
38	39592 AN	Tension Post Bar -----	1
39	39592 AG-5	Tension Post Mounting Bracket -----	1
40	22806 A	Screw, for tension mounting bracket -----	1
40 A	40-46	Washer -----	1
41	22847 B	Screw, for tension post mounting bracket -----	1
42	39592 AH	Nut, for tension post -----	3 or 4
43	22541 B	Screw -----	1
44	39582 EW	Feed Bar Cover Latch -----	1
45	88 A	Screw -----	1
46	39568 AK	Thread Tube Bracket Assembly -----	1
47	376 A	Screw, for upper looper thread eyelet -----	1
48	39568 E	Auxiliary Lower Loper Thread Eyelet -----	1
49	376 A	Screw, for lower looper thread eyelet -----	1
50	39568 B	Lower Loper Thread Eyelet -----	1
51	39568 L	Upper Loper Thread Eyelet -----	1
52	39568 AD	Looper Thread Eyelet Mounting Bracket -----	1
53	22569 B	Screw, for looper thread eyelet mounting bracket -----	1
54	43139 A	Nut, for looper thread eyelet screw -----	2

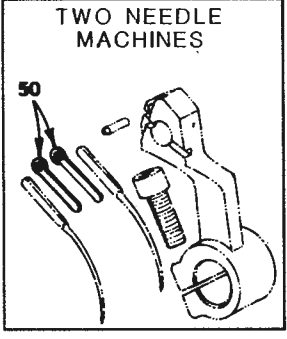
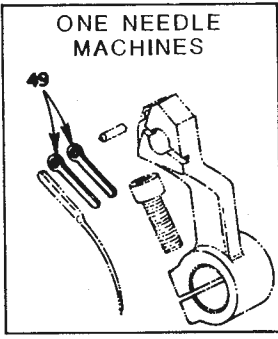
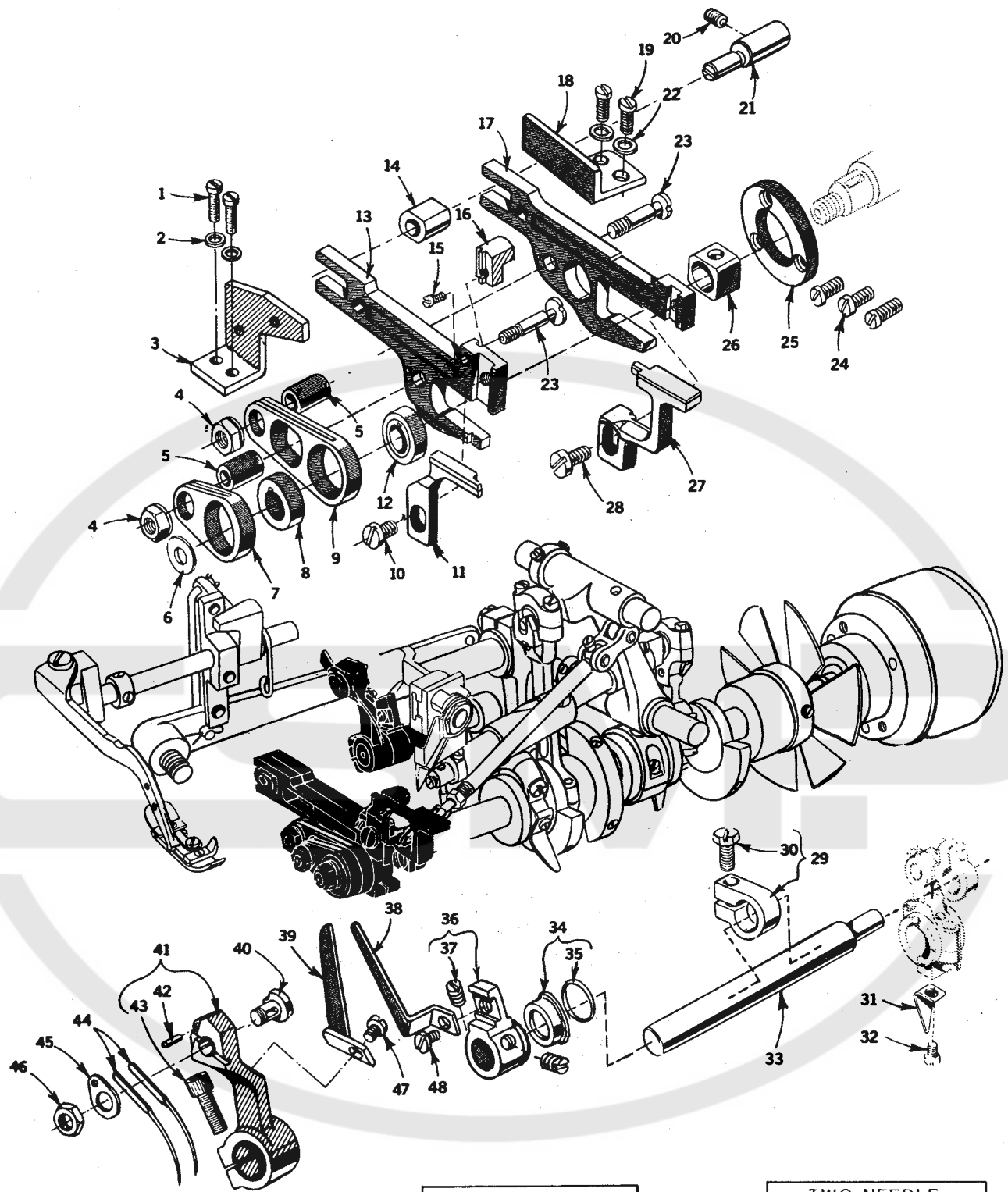

NEEDLE DRIVE AND FEED MECHANISM

<u>Ref. No.</u>	<u>Part No.</u>	<u>Description</u>	<u>Amt. Req.</u>
1	22541 B	Screw, for main feed bar guide, left -----	2
2	8372 A	Washer, for main feed bar guide screw -----	2
3	39535 T	Main Feed Bar Guide, left -----	1
4	39536 E	Nut, for feed bar driving stud -----	2
5	39536 C	Feed Bar Driving Stud Bushing -----	2
6	40-46	Washer, for crankshaft -----	1
7	39536 AF	Main Feed Bar Driving Connection -----	1
8	39540 B-12	Main Feed Driving Eccentric -----	1
9	39536 AE	Differential Feed Bar Driving Connection -----	1
10	93 A	Screw, for main feed dog -----	1
11	39505 AB	Main Feed Dog -----	1
12	39540 B-14	Differential Feed Driving Eccentric -----	1
13	39534 AC	Main Feed Bar -----	1
14	39535 J	Feed Bar Guide Block -----	1
15	22797 A	Screw for knife drive block -----	1
16	39573 DA	Knife Drive Block -----	1
17	39534 G	Differential Feed Bar -----	1
18	39535 U	Differential Feed Bar Guide, right -----	1
19	22569 B	Screw, for differential feed bar guide, right -----	2
20	22894 R	Screw, for feed adjusting pin -----	1
21	39535 AB	Feed Adjusting Pin, marked "C" -----	1
22	53634 C	Washer, for differential feed bar guide screw -----	2
23	39535 B	Feed Bar Driving Stud -----	2
24	22569 G	Screw, for thrust washer -----	3
25	39534 AF	Differential Feed Bar Thrust Washer -----	1
26	39538	Feed Lift Block -----	1
27	39526 AB	Differential Feed Dog -----	1
28	22528	Screw, for differential feed dog -----	1
29	39543 Y	Needle Drive Shaft Thrust Collar -----	1
30	22782 A	Screw, for needle drive shaft thrust collar -----	1
31	39594 N	Oil Splasher -----	1
32	87 U	Screw, for oil splasher -----	1
33	39522 AN	Needle Driving Shaft -----	1
34	39552 AG	Oil Seal, for needle driving shaft -----	1
35	660-207	Oil Seal Ring -----	1
36	39568 AL	Looper Thread Pull-off Lever -----	1
37	88 B	Screw, for looper thread pull-off lever -----	2
38	39568 AH	Looper Thread Pull-off -----	1
39	39563 P	Needle Thread Cam Pull-off -----	1
40	39551 S	Needle Clamp Stud -----	1
41	39552 AW	Needle Driving Arm, marked "X" -----	1
42	39552 AD	Stop Pin, for needle -----	1
43	22596 E	Screw, for needle driving arm -----	1
44	154 GFS	Needle, for two needle machines -----	2
	154 GHS	Needle, for single needle machines -----	1
45	39551 R	Needle Clamp Washer -----	1
46	14077 A	Nut, for needle clamp stud -----	1
47	87 U	Screw, for needle thread cam pull-off -----	1
48	22513	Screw, for looper thread pull-off -----	1
49	39551 L	Needle Spacer, (.022 inch)(.556 mm) Thick for one needle machines -----	1
50	39551 P	Needle Spacer, (.012 inch)(.305 mm) Thick, for two needle machines -----	1

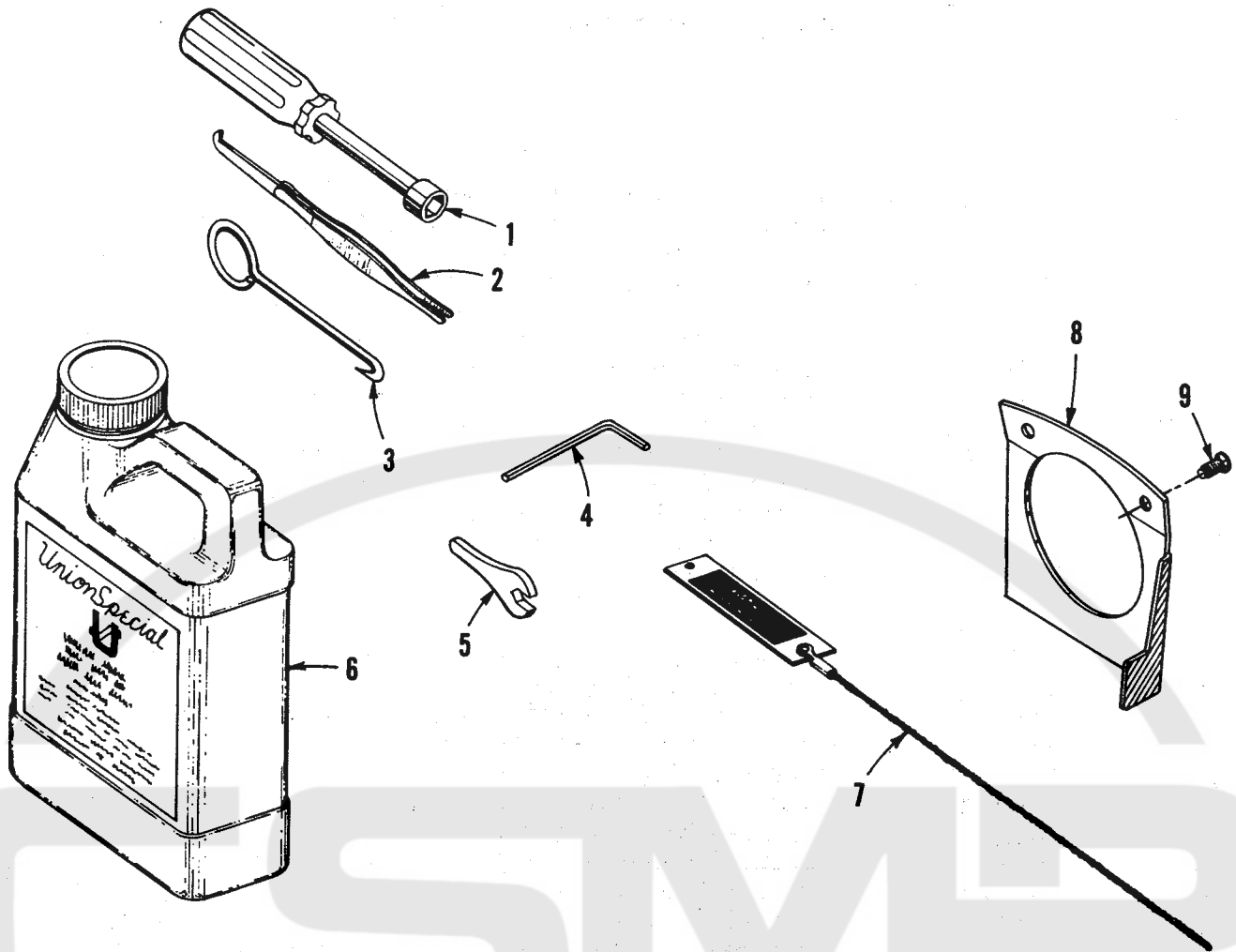

ACCESSORIES

<u>Ref. No.</u>	<u>Part No.</u>	<u>Description</u>	<u>Amt. Req.</u>
1	21388-AU	Socket Wrench, Size 3/8" -----	1
2	118	Tweezers -----	1
3	21227 BF	Feed Eccentric Hook -----	1
4	WR65	Allen Wrench, Size 1/16" -----	1
5	116	Wrench, Size 9/32 -----	1
6	28604 R	Machine oil 16 Fl. oz. -----	1
7	39899 A	Looper Threader -----	1
8	21375 BB	Belt Guard -----	1
9	80	Belt Guard Screws -----	2
(not shown)		Plastic Machine Cover -----	1
(not shown)		Threading Diagram -----	1

OIL METERING PIN

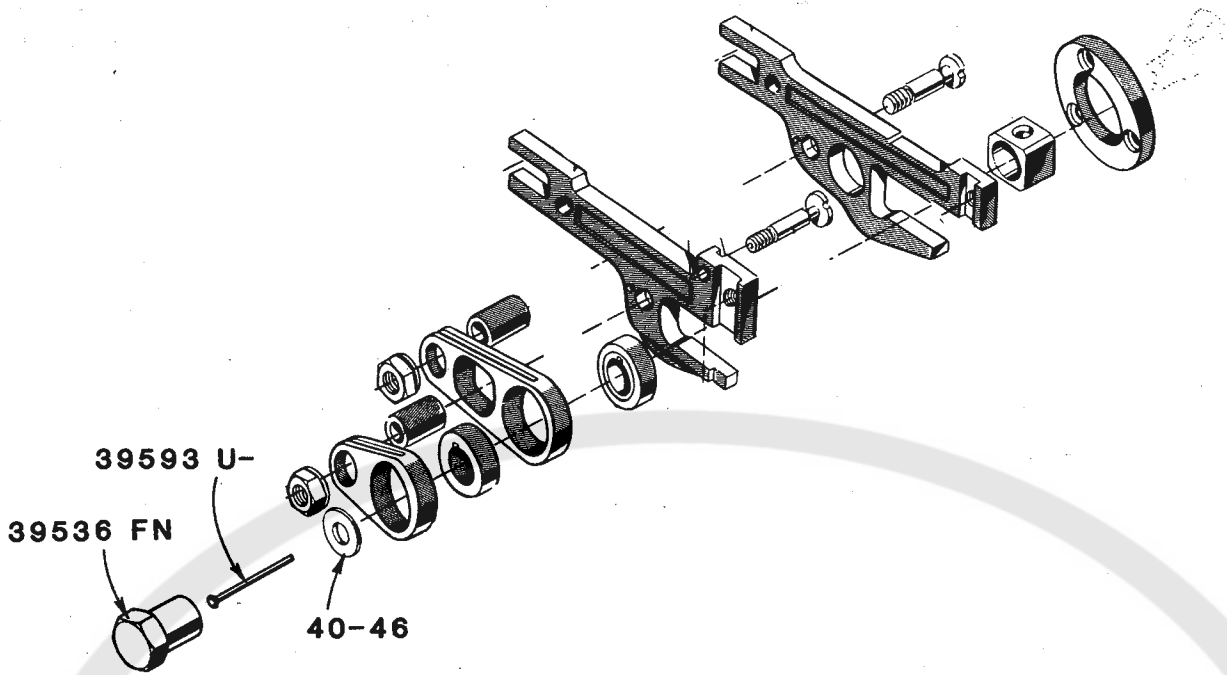

Beginning with machine serial number 1620485 the wood oil metering plug is now being replaced by a steel metering pin which is inserted inside the main shaft on all Class 39500 Machines.

The pin is easy to remove. On the "Mark IV" machines the head is protruding beyond the end of the shaft and it can be pulled out with a tweezers. With the wood plug the rate of oil flow was determined by the grain of the wood itself and could not be varied or adjusted. The steel pin, on the other hand, can be easily replaced with a slightly larger or smaller diameter pin to reduce or increase the flow to a precise degree.

NOTE: One final point - metering pins can not be added to machines with serial numbers below 1620485, because the crankshafts are not prepared for them. A new crankshaft assembly would have to be installed with the pre-selected metering pin in it.

39593 U	METERING PIN SIZE CHART		
	PART NUMBER	PIN DIAMETER	
		INCH	mm
	39593 U-125	0.1250	3.175
	39593 U-126	0.1260	3.200
	39593 U-1265	0.1265	3.213
	39593 U-127	0.1270	3.225
	39593 U-1275	0.1275	3.238
	39593 U-128	0.1280	3.251
	39593 U-1285	0.1285	3.263
	39593 U-129	0.1290	3.276

MACHINE INVENTORY INFORMATION

Unit Number	Maker's Name	Machine Style	Serial Number	Needle Type	Date Of Purchase

ADDITIONAL INFORMATION: _____

Notes:

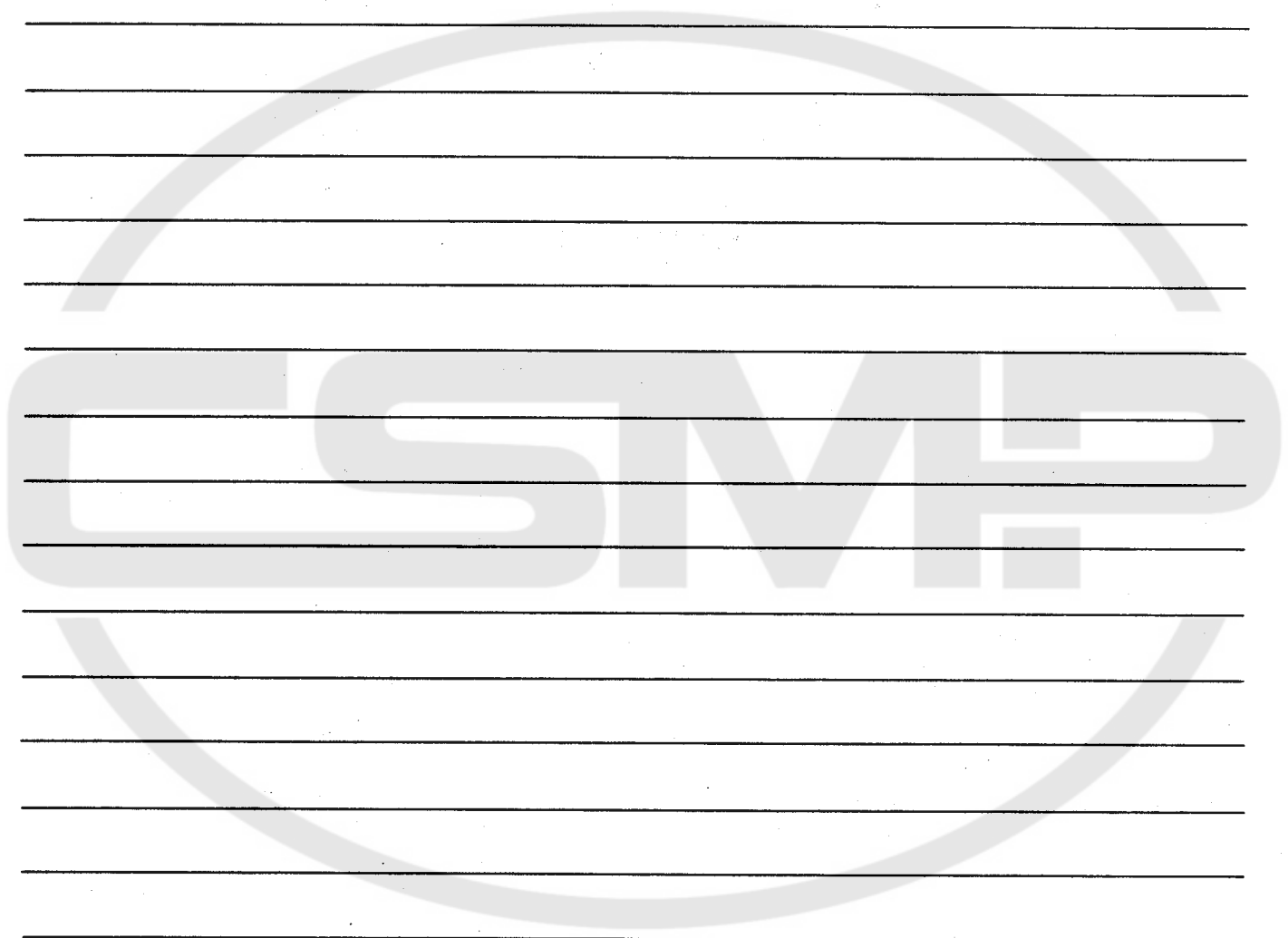



Union Special
INDUSTRIAL SEWING EQUIPMENT