

Pfaff
Mauser Spezial 9752

CSMP

PFAFF[®]

**MAUSER
SPEZIAL[®] 9752**

CSMP

Bestandteilleliste

List of spare parts

Liste de pièces détachées

Lista de piezas de repuesto

Achtung!

Ersatzteile bitte nur mit den im
Index aufgeführten **PFAFF-NUMMERN**
Bestellen (siehe Seiten 76 bis 80).

Important note:

For spare part orders please only
use the **PFAFF-NUMBERS** listed in
the index (pages 76 to 80).

Important!

Veuillez commander les pièces de
rechange uniquement avec leur
référence complète précisée à
l'index (pages 76 à 80).

Atencion!

Sírvanse hacer sus pedidos sólo
con los **NUMEROS-PFAFF** indicados
en el índice (véanse las
páginas 76 à 80).

TABLE OF CONTENTS

	Page
MACHINE BED FRAME(1)~(2) _____	2~5
COVERS(1)~(2) _____	6~9
CRANKSHAFT DRIVE MECHANISM(1)~(2) _____	10~13
NEEDLE DRIVE MECHANISM(1)~(2) _____	14~17
UPPER LOOPER DRIVE MECHANISM(1)~(2) _____	18~21

LOWER LOOPER DRIVE MECHANISM _____	22~23
FEED MECHANISM(1)~(2) _____	24~27
TOP FEED MECHANISM(1)~(2) _____	28~31
KNIFE DRIVE MECHANISM _____	32~33
PRESSER FOOT MECHANISM _____	34~35
LUBRICATING MECHANISM _____	36~37

LUBRICATING MECHANISM(OLD TYPE) _____	38~39
H. R. DEVICE _____	40~41
SHIRRING ATTACHMENT _____	42~43
K L DEVICE _____	44~45
EDGE GUIDE PIPING ATTACHMENT _____	46~47

SEMI-SUBMERGED INSTALLATION _____	48~49
ACCESSORIES _____	50~51
THREAD STAND _____	52~53
GAUGE PARTS CONSTRUCTION CHART _____	54~67
GAUGE PARTS LIST(1)~(8) _____	68~75

PART NUMBER INDEX _____	76~80

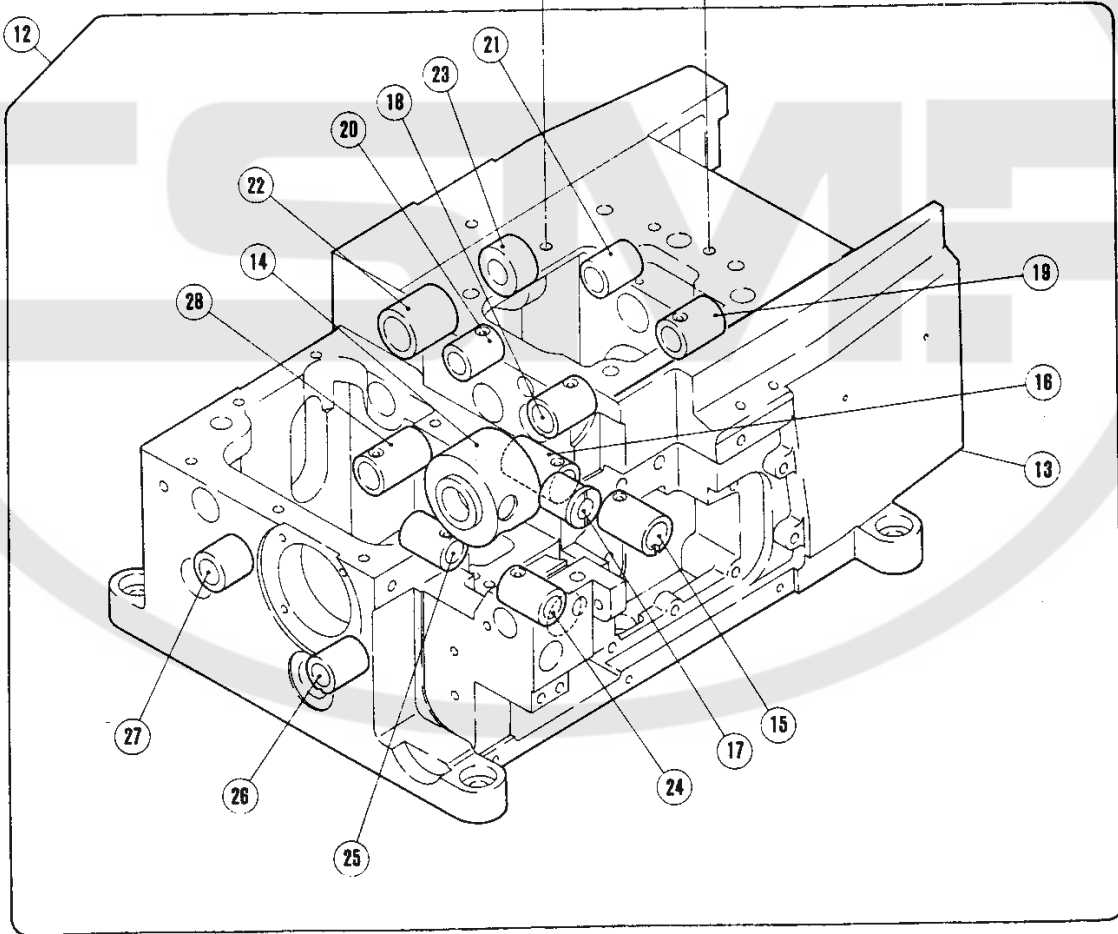
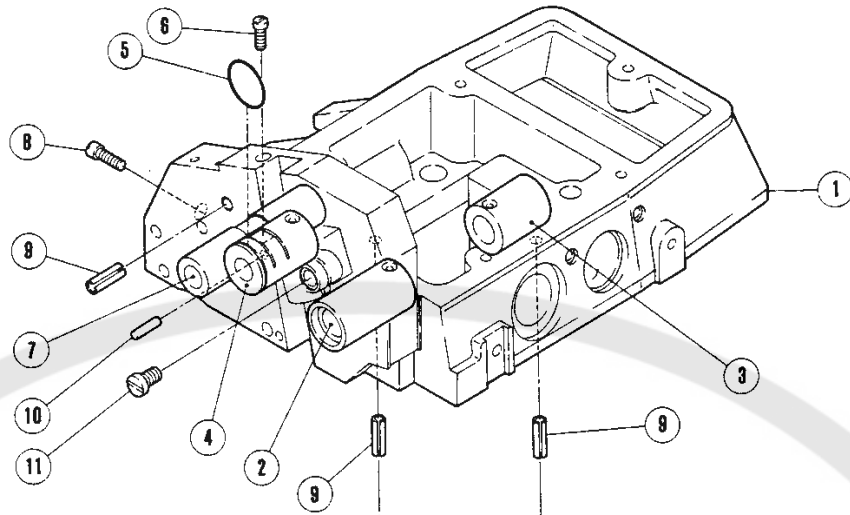

MACHINE BED FRAME(1)

REF. NO.	PART NO.	NAME	QT.	MEMO
1	212001-CD	MACHINE ARM (RIGHT)	1	
2	210234	BUSHING	1	
3	210233	BUSHING	1	
4	210242	BUSHING	1	
5	210057	O RING	1	
6	2133-1	SCREW	1	
7	212048	BUSHING	1	
8	2133-1	SCREW	1	
9	201002	PIN	3	
10	211385	PIN	1	
11	5357	SCREW	1	
*12	212325-CD	MACHINE BED COMPLETE	1	
*13	212821-CD	MACHINE BED	1	
14	211533	BUSHING	1	
15	210101	BUSHING	1	
16	210102	BUSHING	1	
17	210110	BUSHING	1	
18	210068	BUSHING	1	
19	210067	BUSHING	1	
20	212154	BUSHING	1	
21	210297	BUSHING	1	
22	212037	BUSHING	1	
23	212038	BUSHING	1	
24	210124	BUSHING	1	
25	210125	BUSHING	1	
26	210164	BUSHING	1	
27	210143	BUSHING	1	
28	210102	BUSHING	1	

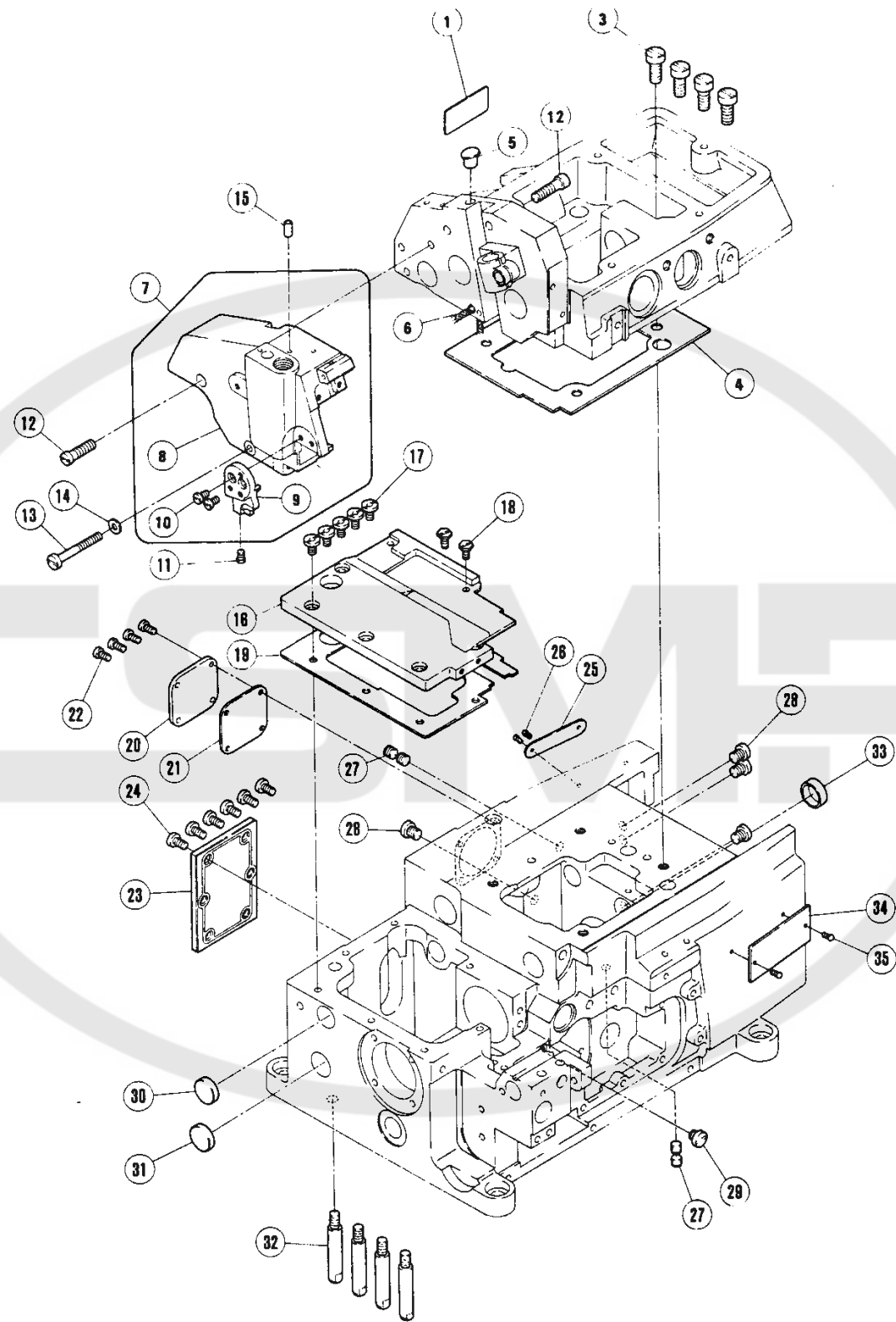

MACHINE BED FRAME(2)

REF. NO.	PART NO.	NAME	QT.	MEMO
1	205724	NAME PLATE	1	
3	5078	SCREW	4	
4	210002	GASKET	1	
5	240052	PLUG	1	
* 6	202175	OIL WICK	1	
* 7	212489ACD	MACHINE ARM (LEFT) ASSEMBLY	1	
8	212004ACD	MACHINE ARM (LEFT)	1	
9	211389-CD	ARM COVER (LEFT)	1	
10	5328	SCREW	2	
11	5146	SCREW	1	
12	5163	SCREW	1	
13	5595	SCREW	1	
14	200149	GASKET	1	
15	210528	OIL PIPE	1	
16	212007	BED PLATE	1	
17	4009-1	SCREW	5	
18	5482	SCREW	2	
19	212008	GASEKT	1	
20	212010-CD	COVER PLATE	1	
21	212011	GASKET	1	
22	5142	SCREW	4	
23	210005	COVER PLATE	1	
24	5117	SCREW	6	
*25	230047	SERIAL NUMBER PLATE	1	
26	210679	PIN	2	
27	2913-1	SCREW	4	
28	5332A	SCREW	4	
29	5434A	SCREW	1	
30	208173	PLUG	1	
31	210003	PLUG	1	
32	204006	BED PIN	4	
33	210003	PLUG	1	
*34	212281A	TYPE PLATE	1	
35	210679	PIN	2	

Notice) Parts with mark * are not for sale.

COVERS(1)

REF. NO.	PART NO.	NAME	QT.	MEMO
1	210883	CLOTH PLATE(WIDE)	1	
2	210022	SCREW	1	
3	137906	WASHER	1	
4	211300	NUT	1	
5	210024	SPRING	1	
6	5012	SCREW	2	
7	202875	WASHER	2	
8	210025	CUSHION	1	
9	210027-CB	SIDE COVER (WIDE)	1	
10	4009-1	SCREW	3	
11	201185	WASHER	3	
12	210025	CUSHION	2	
13	210020	WASHER	1	
14	192130	SPRING	1	
15	5483	SCREW	1	
16	3044	NUT	1	
17	210881	CLOTH PLATE (NARROW)	1	
18	210026-CB	SIDE COVER (NARROW)	1	
19	1174	SCREW	1	
20	3091	NUT	1	
21	210021	LATCH	1	
22	5488	SCREW	1	
23	210023	SPRING	1	
24	208245	WASHER	1	
25	1435	SCREW	1	
26	1459	SCREW	1	
27	210022	SCREW	1	
28	210025	CUSHION	2	
29	210007	FEED BAR COVER	1	
30	2905	SCREW	2	
31	210006	COVER/FEED ECCENTRIC	1	
32	5480	SCREW	2	
33	210117	UPPER LOOPER HOLDER COVER	1	
34	4009-1	SCREW	5	

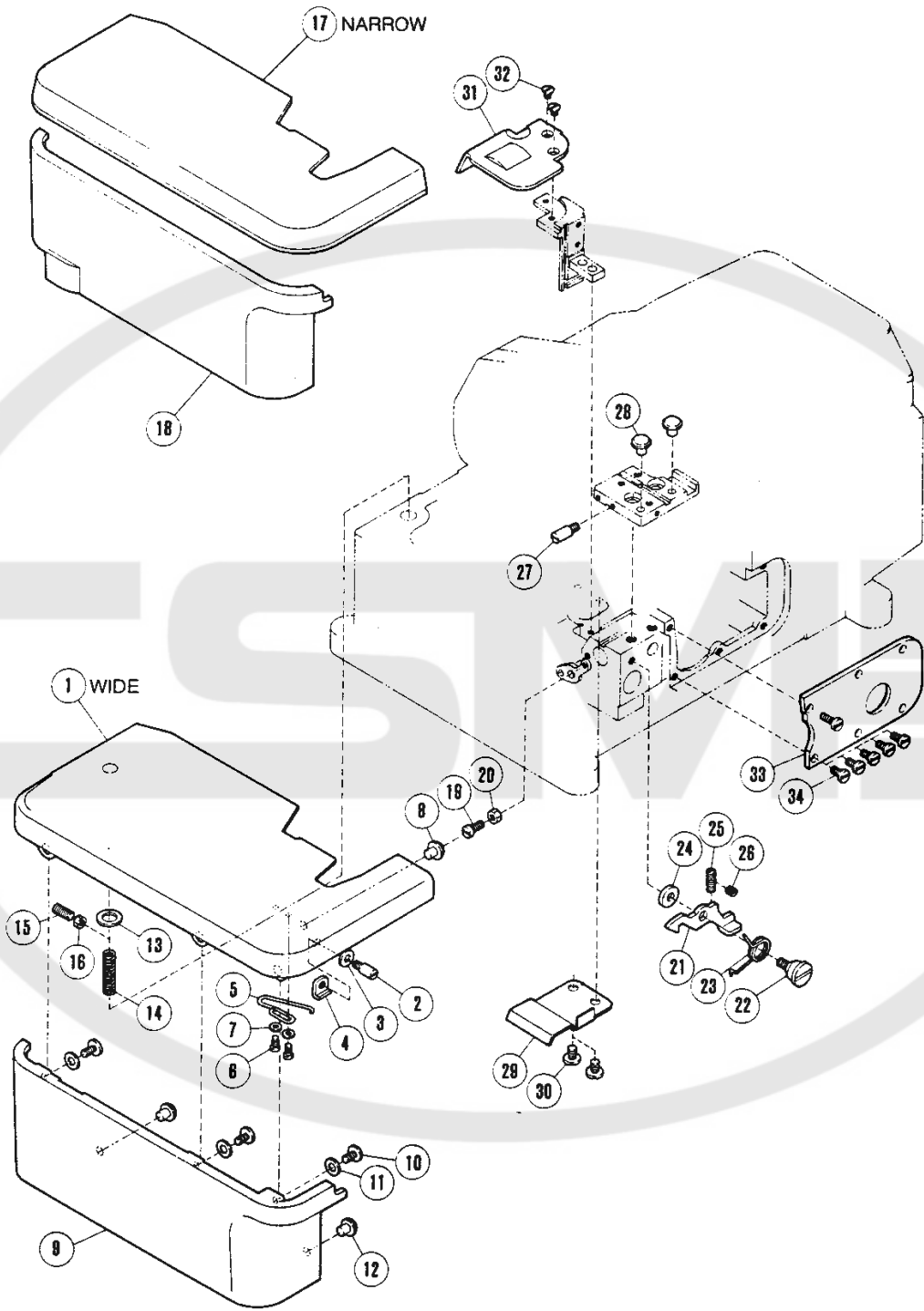

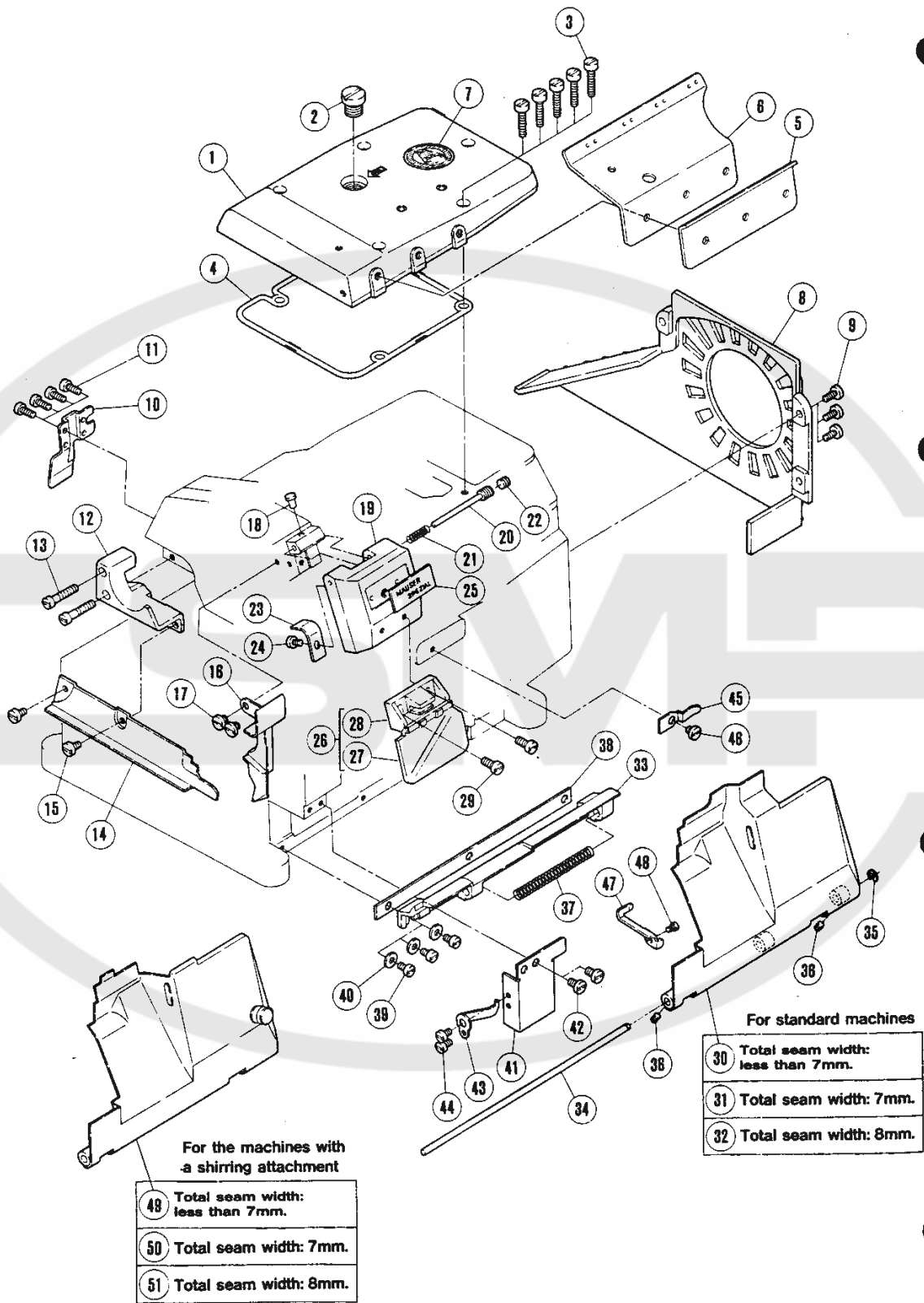

COVERS(2)

REF. NO.	PART NO.	NAME	QT.	MEMO
1	211799-CD	TOP COVER	1	
2	5198	SCREW	1	
3	5095	SCREW	5	
4	210035	O RING	1	
5	211800	TENSION GUIDE	1	
6	211801	THREAD TENSION COMPLETE	1	
* 7	211313	NAME PLATE	1	
8	210028-CB	BELT COVER	1	
9	5117	SCREW	3	
10	212009	REAR COVER	1	
11	5142	SCREW	4	
12	212006	BRACKET	1	
13	5163	SCREW	2	
14	212005	FABRIC GUARD	1	
15	2905	SCREW	2	
16	212609-91	COVER/MACHINE ARM LEFT	1	
17	2905	SCREW	2	
18	198192	CUSHION RUBBER	1	
19	211959-BD	NEEDLE THREAD COVER	1	
20	5589	SCREW	1	
21	211958	SPRING	1	
22	5060	SCREW	1	
23	210223	FLAT SPRING	1	
24	1216	SCREW	1	
25	205724	NAME PLATE	1	
26	208747	EYE GUARD COMPLETE	1	
27	205685	EYE GUARD	1	
28	208744	EYE GUARD BRACKET COMPLETE	1	
29	1175-3	SCREW	2	
30	210225	FRONT COVER	1	
31	211702	FRONT COVER	1	
32	211794	FRONT COVER	1	
33	210042	HINGE/FRONT COVER	1	
34	208009	PIN	1	
35	200555	RING	1	
36	5292	SCREW	2	
37	210043	SPRING	1	
38	210047	GASKET	1	
39	1202	SCREW	3	
40	137906	WASHER	3	
41	210046	GUIDE/FRONT COVER	1	
42	4009-1	SCREW	2	
43	210045	FLAT SPRING	1	
44	1216	SCREW	2	
45	210044	FLAT SPRING	1	
46	2905	SCREW	1	
47	211840	STOPPER/FRONT COVER	1	
48	5012	SCREW	1	
49	211698	FRONT COVER	1	
50	211698A	FRONT COVER	1	
51	211698B	FRONT COVER	1	

Notice) Parts with mark * are not for sale.

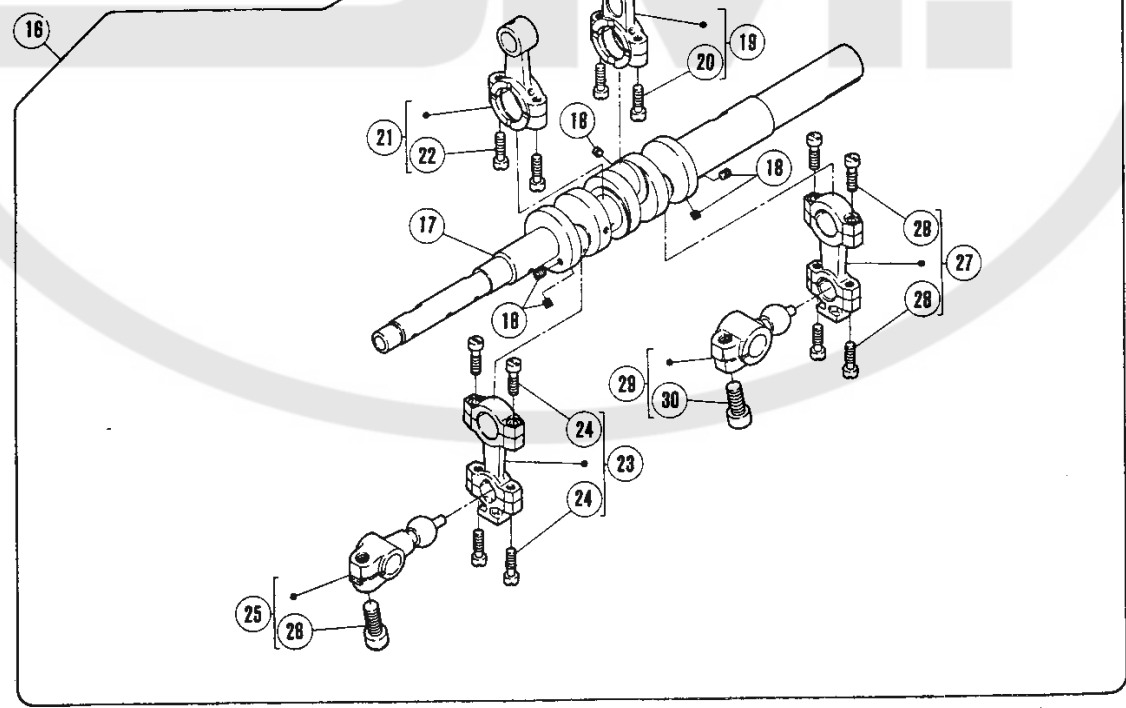
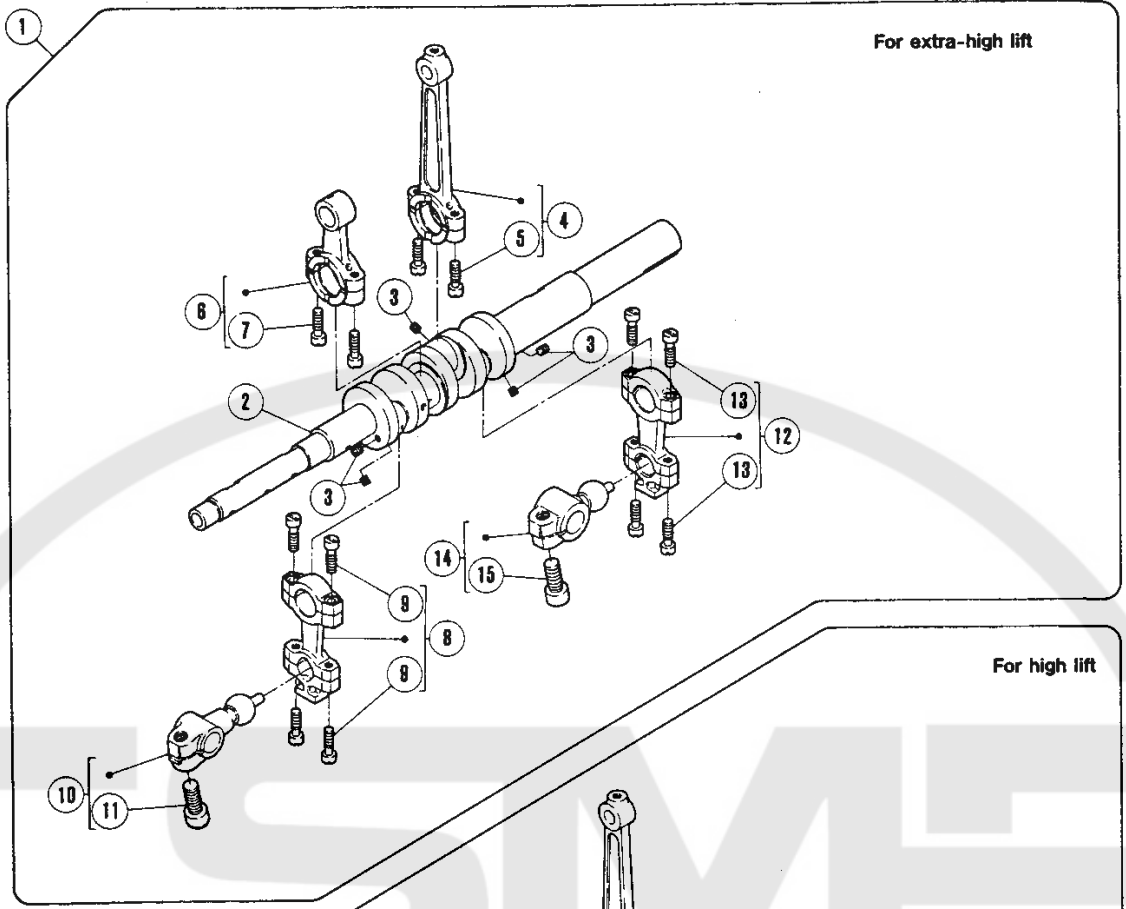

CRANKSHAFT DRIVE MECHANISM(1)

REF. NO.	PART NO.	NAME	QT.	MEMO
1	212670B	CRANKSHAFT ASSEMBLY	1	
2	210228-PD	CRANKSHAFT	1	
3	1459	SCREW	5	
4	210229	CONNECTION/NEEDLE DRIVE	1	
5	5376	SCREW	2	
6	210173	CONNECTION/UPPER KNIFE DRIVE	1	
7	5376	SCREW	2	
8	210091	CONNECTION	1	
9	5376	SCREW	4	
10	211652	CRANK/LOWER LOOPER HOLDER	1	
11	5457	SCREW	1	
12	210091	CONNECTION	1	
13	5376	SCREW	4	
14	210731	CRANK/UPPER LOOPER	1	
15	5457	SCREW	1	
16	212657B	CRANKSHAFT ASSEMBLY	1	
17	210228-PC	CRANKSHAFT	1	
18	1459	SCREW	5	
19	210229	CONNECTION/NEEDLE DRIVE	1	
20	5376	SCREW	2	
21	210173	CONNECTION/UPPER KNIFE DRIVE	1	
22	5376	SCREW	2	
23	210091	CONNECTION	1	
24	5376	SCREW	4	
25	210734	CRANK/LOWER LOOPER DRIVE	1	
26	5457	SCREW	1	
27	210091	CONNECTION	1	
28	5376	SCREW	4	
29	210731	CRANK/UPPER LOOPER	1	
30	5457	SCREW	1	

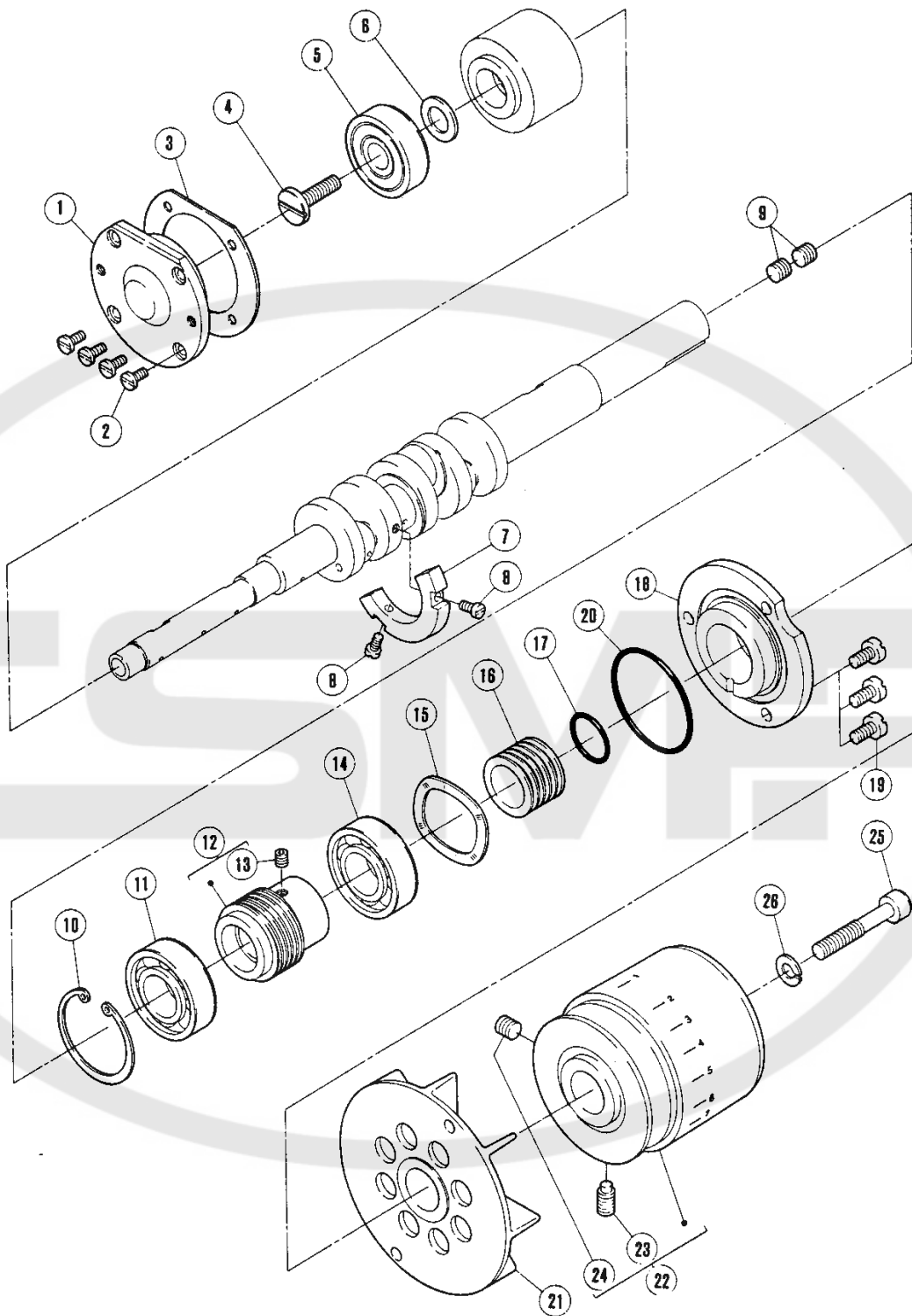

CRANKSHAFT DRIVE MECHANISM(2)

REF. NO.	PART NO.	NAME	QT.	MEMO
1	204737A	HOUSING	1	
2	5328	SCREW	4	
3	204319	GASKET	1	
4	5497	SCREW	1	
5	204010	BUSHING	1	
6	240102	WASHER	1	
7	210062	BALANCE WEIGHT	1	
8	5029	SCREW	2	
9	1448	SCREW	2	
10	211527	RING	1	
11	212987	BALL BEARING	1	
12	211530	WORM	1	
13	5461	SCREW	1	
14	211526	BALL BEARING	1	
15	211529	WASHER	1	
16	210056	OIL SEAL	1	
17	210057	O RING	1	
18	211528	BALL BEARING RETAINER	1	
19	5117	SCREW	3	
20	210055	O RING	1	
21	210058	COOLING FAN	1	
22	211345ABD	MACHINE PULLEY	1	
23	5523	SCREW	1	
24	5050	SCREW	1	
25	5522	SCREW	1	
26	204293	SPRING WASHER	1	

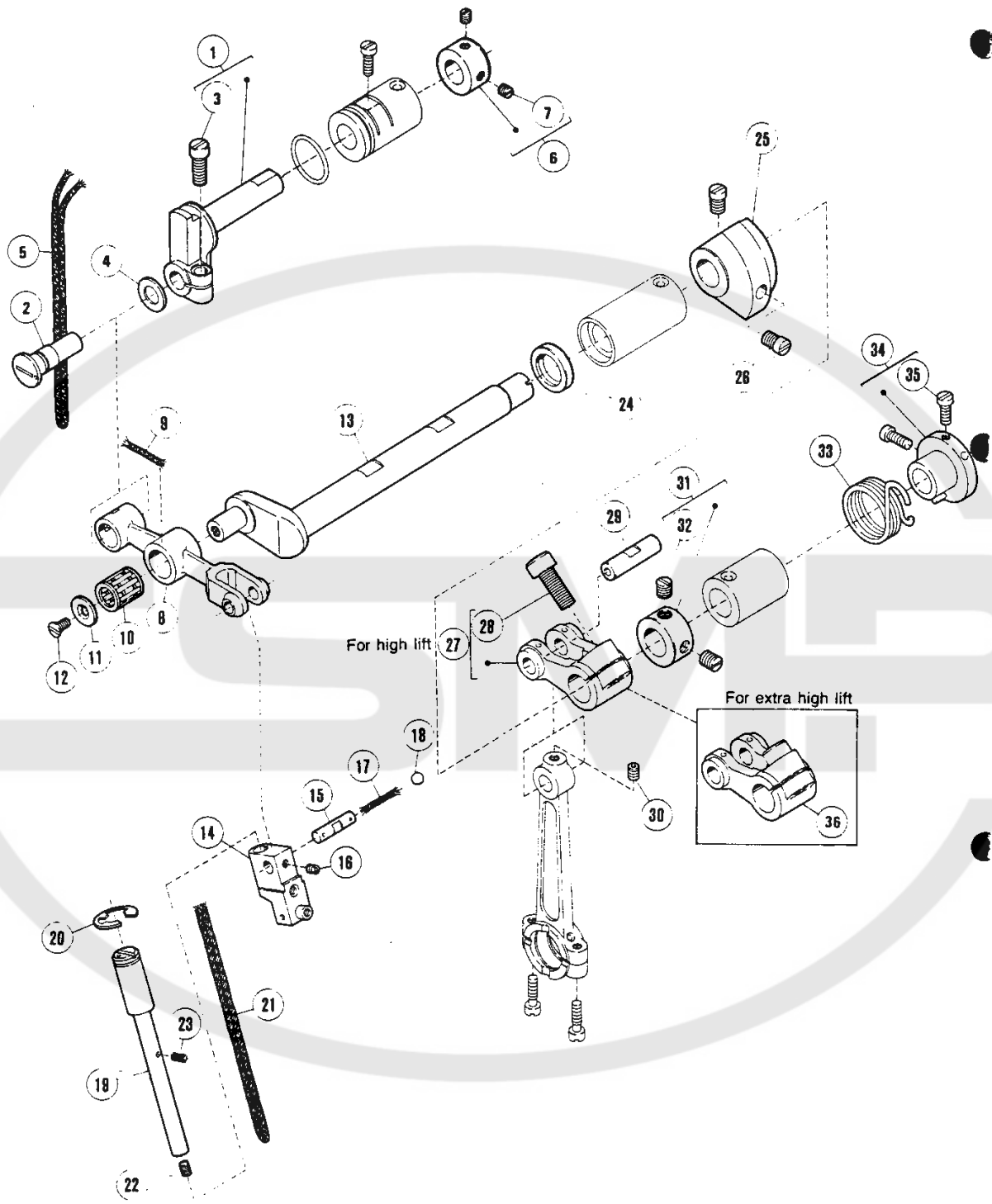

NEEDLE DRIVE MECHANISM(1)

REF. NO.	PART NO.	NAME	QT.	MEMO
1	210239	HOLDER	1	
2	210240	PIN	1	
3	5485	SCREW	1	
4	210241	WASHER	1	
* 5	212186	OIL WICK	1	
6	201056	COLLAR	1	
7	1457	SCREW	1	
8	210235	LEVER/NEEDLE DRIVE	1	
* 9	202175	OIL WICK	1	
10	210238-2	NEEDLE BEARING	1	
11	210236	WASHER	1	
12	5022	SCREW	1	
13	210232	SHAFT/NEEDLE DRIVE	1	
14	212412A	NEEDLE HOLDER GUIDE	1	
15	210237A-2	PIN	1	
16	5292	SCREW	1	
*17	202174	OIL WICK	1	
18	240148	PLUG	1	
19	212413	SHAFT	1	
20	202577	RING	1	
*21	202175	OIL WICK	1	
22	5292	SCREW	1	
*23	202174	OIL WICK	1	
24	210069	OIL SEAL	1	
25	210511	BALANCE WEIGHT	1	
26	5059	SCREW	2	
27	210231	CRANK/NEEDLE DRIVE	1	
28	5457	SCREW	1	
29	211649	CRANK/NEEDLE DRIVE	1	
30	204146	PIN	1	
31	5461	SCREW	1	
32	201635	COLLAR	1	
33	5060	SCREW	2	
34	212785	SPRING	1	
35	212786-91	COLLAR	1	
36	1174	SCREW	2	

Notice) Parts with mark * are not for sale.

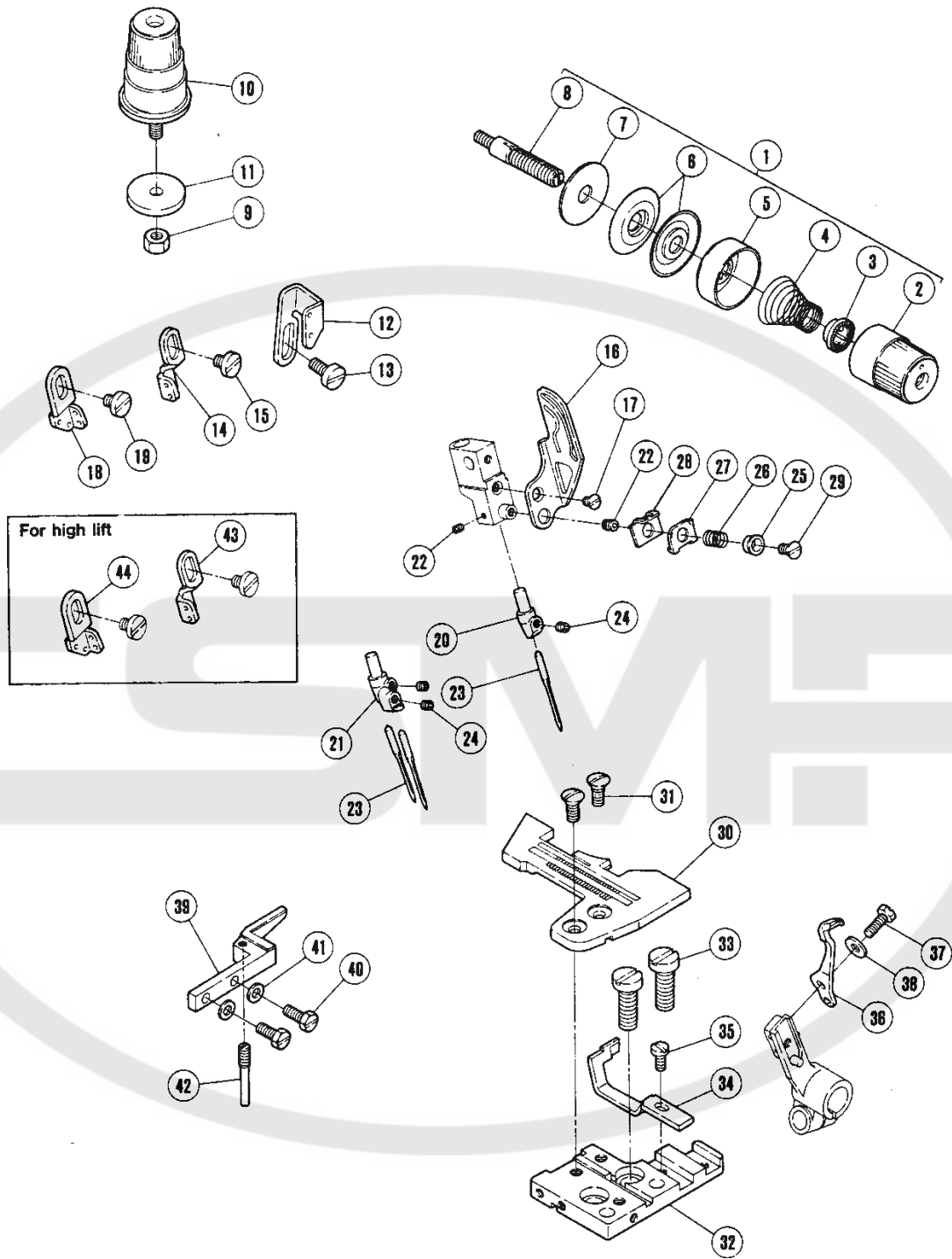

NEEDLE DRIVE MECHANISM(2)

REF. NO.	PART NO.	NAME	QT.	MEMO
1	210529-BA	THREAD TENSION COMPLETE	1	
2	208447	POST NUT	1	
3	208448	SPRING BUSHING	1	
4	201037	SPRING (HEAVY)	1	
5	208450	CUP	1	
6	210319	TENSION DISC	2	
7	208449	FELT	1	
8	5082A	SCREW STUD	1	
9	5137	NUT	1	
10	210529-BA	THREAD TENSION COMPLETE	1	
11	201880	WASHER	1	
12	210264	THREAD GUIDE	1	
13	5117	SCREW	1	
14	212723A	NEEDLE/THREAD GUIDE(RIGHT)	1	
15	5535	SCREW	1	
16	212721	THREAD TAKEUP	1	
17	5446	SCREW	1	
18	212722A	NEEDLE/THREAD GUIDE(LEFT)	1	
19	5535	SCREW	1	
20	211358	NEEDLE HOLDER	1	
21	XXXXXX	NEEDLE HOLDER	1	
22	5292	SCREW	2	
23	XXXXXX	NEEDLE		
24	5292	SCREW		
25	210750	GUIDE	1	
26	210751	SPRING	1	
27	212504	TENSION DISC	1	
28	212503	BRACKET	1	
29	5022	SCREW	1	
30	XXXXXX	NEEDLE PLATE	1	
31	5484-HC	SCREW	2	
32	211392	BRACKET COMPLETE	1	
33	5357	SCREW	2	
34	XXXXXX	NEEDLE GUARD (FRONT)	1	
35	5328	SCREW	1	
36	210724	NEEDLE GUARD (REAR)	1	
37	5501	SCREW	1	
38	210930	SPRING WASHER	1	
39	210922	SUPPORT COMPLETE/NEEDLE PLATE	1	
40	5501	SCREW	2	
41	210898	WASHER	2	
42	210923	SCREW	1	
43	212723	NEEDLE/THREAD GUIDE(RIGHT)	1	
44	212722	NEEDLE/THREAD GUIDE(LEFT)	1	

See pages 54~75 for ×××××.

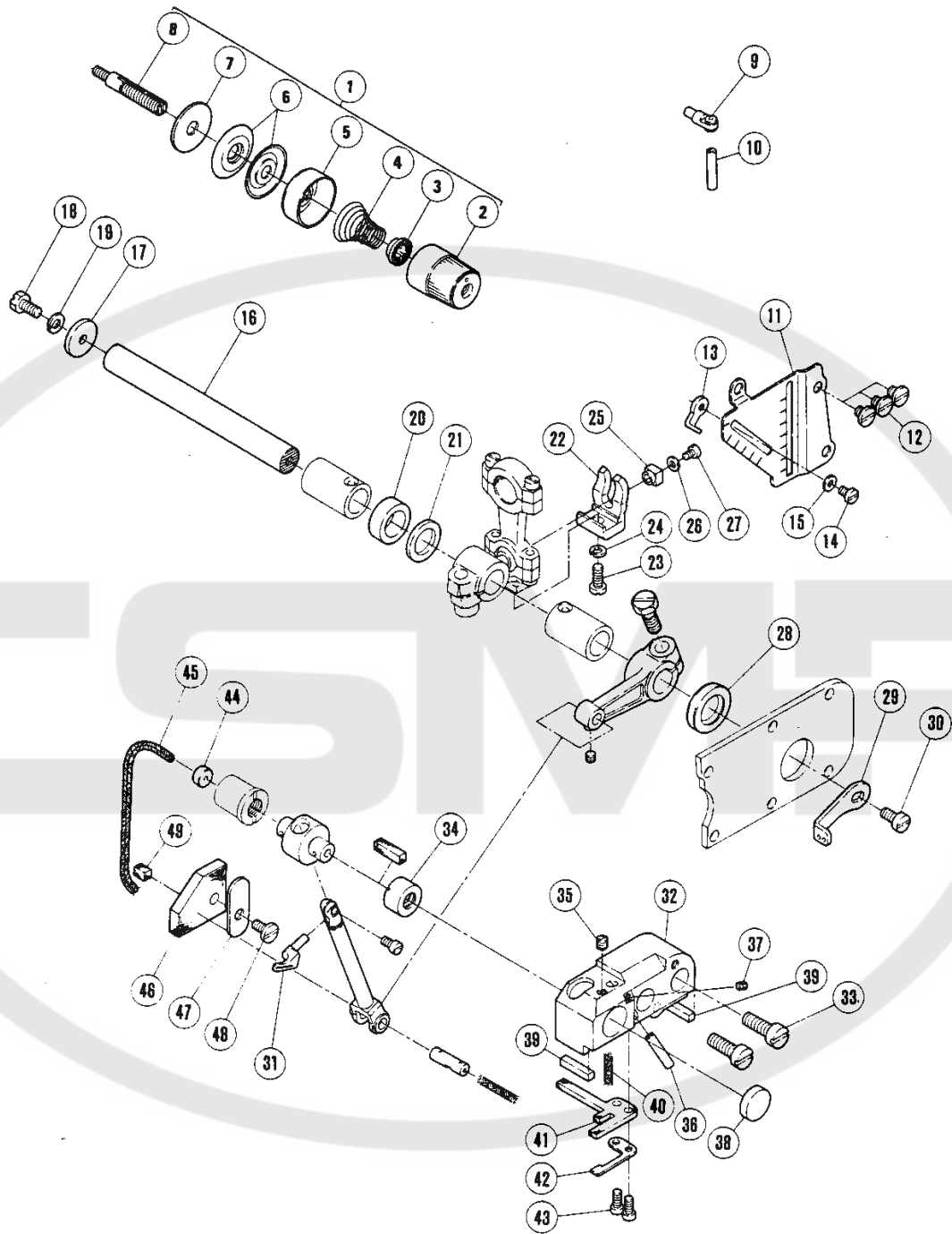

UPPER LOOPER DRIVE MECHANISM(1)

REF. NO.	PART NO.	NAME	QT.	MEMO
1	210531-BA	THREAD TENSION COMPLETE	1	
2	208447	POST NUT	1	
3	208448	SPRING BUSHING	1	
4	201068	SPRING (LIGHT)	1	
5	208450	CUP	1	
6	210319	TENSION DISC	2	
7	208449	FELT	1	
8	5082A	SCREW STUD	1	
9	201439A	THREAD EYELET	1	
10	204657	PIPE	1	
11	210349	LOOPER THREAD GUIDE PLATE	1	
12	2905	SCREW	3	
13	210350	THREAD GUIDE/UPPER LOOPER	1	
14	5519	SCREW	1	
15	202875	WASHER	1	
16	210099	SHAFT/UPPER LOOPER DRIVE	1	
17	210100	WASHER	1	
18	2193	SCREW	1	
19	202286	SPRING WASHER	1	
20	210267	SPACER	1	
21	206180	WASHER	1	
22	210092	GUIDE/CONNECTION	1	
23	5546	SCREW	1	
24	202286	SPRING WASHER	1	
25	210093	BLOCK	1	
26	210585	WASHER	1	
27	1231	SCREW	1	
28	210103	OIL SEAL	1	
29	212728	THREAD TAKEUP/UPPER LOOPER	1	
30	2902	SCREW	1	
31	XXXXXX	UPPER LOOPER	1	
32	211995	BASE/UPPER LOOPER HOLDER	1	
33	5282	SCREW	2	
34	210109	BUSHING	1	
35	5408	SCREW	1	
36	204657	PIPE	1	
37	5292	SCREW	1	
38	208173	PLUG	1	
39	210118	GASKET	2	
*40	202175	OIL WICK	1	
41	210114	OIL FELT	1	
42	210115	SET PLATE	1	
43	5012	SCREW	2	
44	208592	CAP	1	
*45	202174	OIL WICK	1	
46	210112A	OIL FELT	1	
47	210113	SET PLATE	1	
48	4009-1	SCREW	1	
49	210721	OIL FELT	1	

Notice) Parts with mark * are not for sale.

See pages 54~75 for XXXXXX.

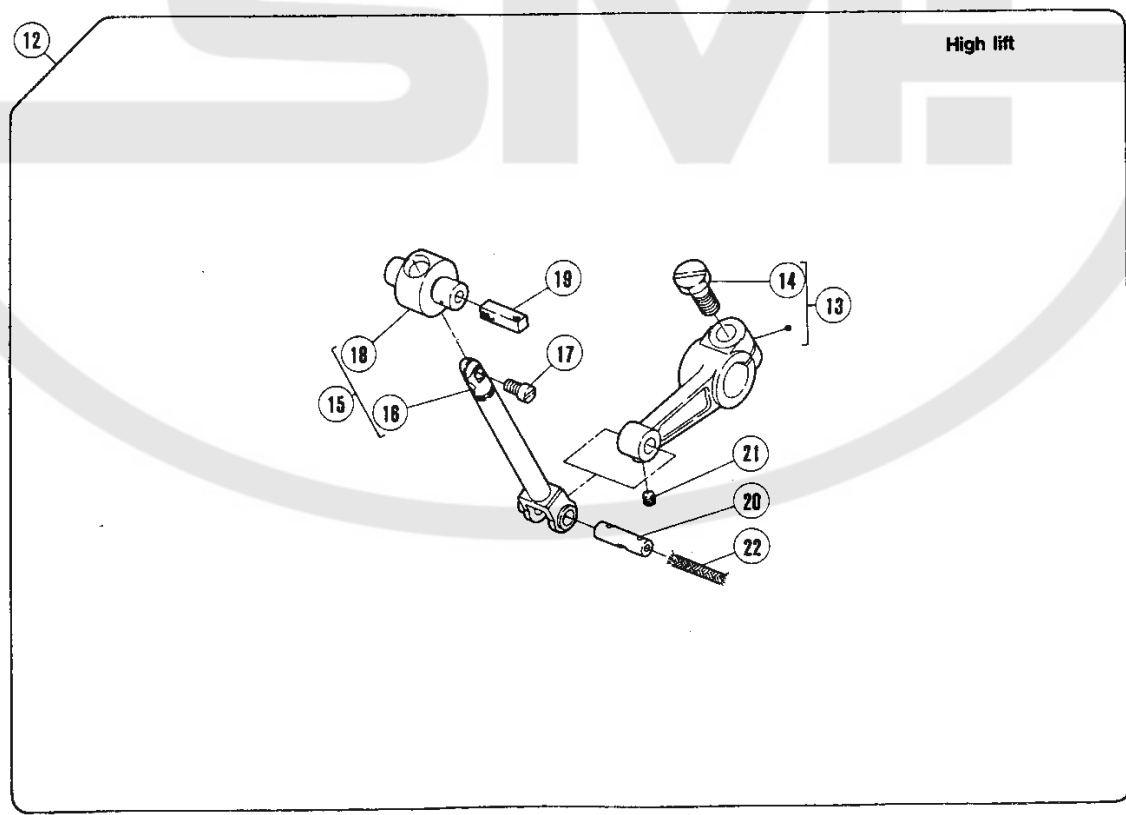
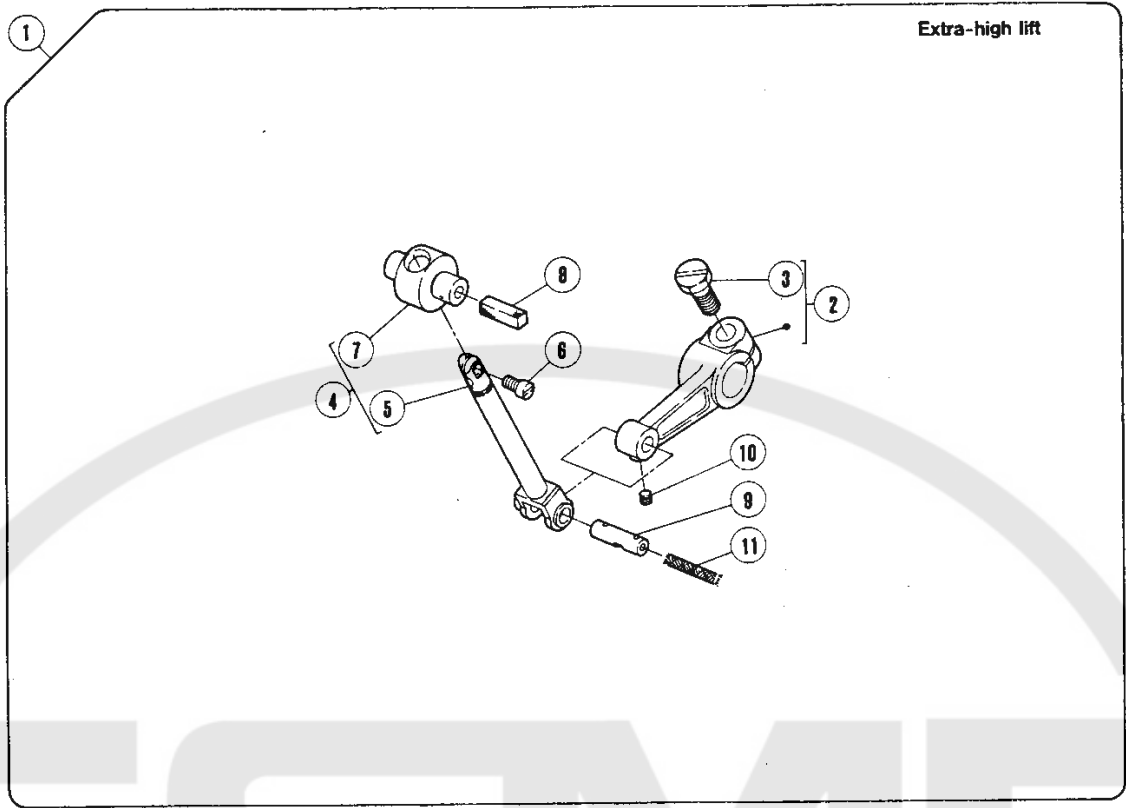

UPPER LOOPER DRIVE MECHANISM(2)

REF. NO.	PART NO.	NAME	QT.	MEMO
1	210929A91	UPPER LOOPER HOLDER ASSEMBLY	1	
2	211655	LEVER/UPPER LOOPER	1	
3	5284	SCREW	1	
4	211926-T	UPPER LOOPER HOLDER ASSEMBLY	1	
5	211654-T	UPPER LOOPER HOLDER	1	
6	1998-2	SCREW	1	
* 7	210107	GUIDE/UPPER LOOPER HOLDER	1	
8	204274	OIL WICK	1	
9	210105-2	PIN	1	
10	5292	SCREW	1	
*11	202174	OIL WICK	1	
12	210928A91	UPPER LOOPER HOLDER ASSEMBLY	1	
13	210104	LEVER/UPPER LOOPER	1	
14	5284	SCREW	1	
15	211926-T	UPPER LOOPER HOLDER ASSEMBLY	1	
16	211654-T	UPPER LOOPER HOLDER	1	
17	1998-2	SCREW	1	
*18	210107	GUIDE/UPPER LOOPER HOLDER	1	
19	204274	OIL WICK	1	
20	210105-2	PIN	1	
21	5292	SCREW	1	
*22	202174	OIL WICK	1	

Notice) Parts with mark * are not for sale.

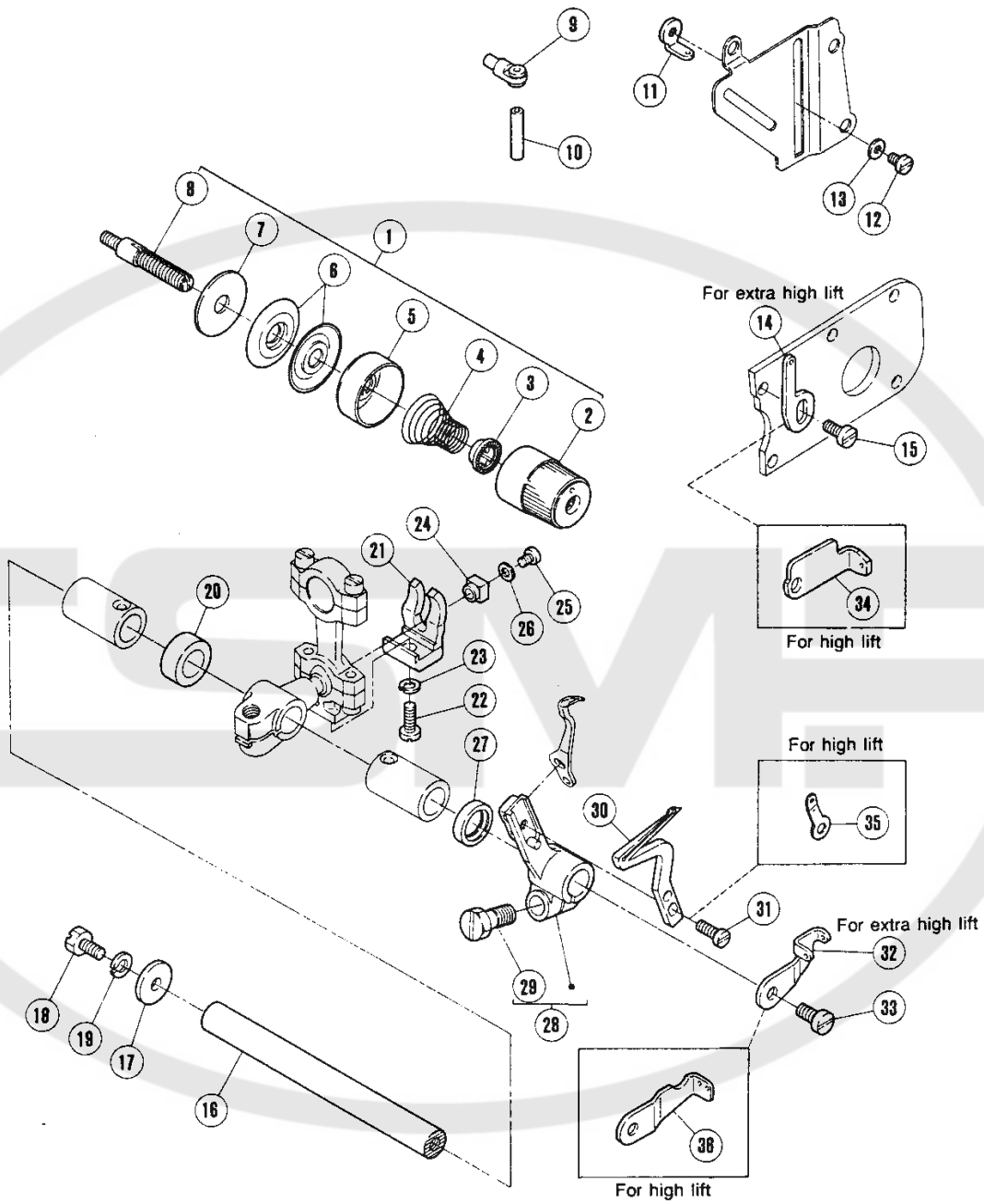

LOWER LOOPER DRIVE MECHANISM

REF. NO.	PART NO.	NAME	QT.	MEMO
1	210530-BA	THREAD TENSION COMPLETE	1	
2	208447	POST NUT	1	
3	208448	SPRING BUSHING	1	
4	201086	SPRING (MEDIUM)	1	
5	208450	CUP	1	
6	210319	TENSION DISC	2	
7	208449	FELT	1	
8	5082A	SCREW STUD	1	
9	201439A	THREAD EYELET	1	
10	204657	PIPE	1	
11	201089	THREAD GUIDE (RIGHT)	1	
12	5519	SCREW	1	
13	202875	WASHER	1	
14	212727	THREAD GUIDE	1	
15	5441	SCREW	1	
16	210123	SHAFT/LOWER LOOPER LEVER	1	
17	204107	WASHER	1	
18	2193	SCREW	1	
19	202286	SPRING WASHER	1	
20	210122	SPACER	1	
21	210092	GUIDE/CONNECTION	1	
22	5546	SCREW	1	
23	202286	SPRING WASHER	1	
24	210093	BLOCK	1	
25	1231	SCREW	1	
26	210585	WASHER	1	
*27	210586	OIL SEAL	1	
28	210725	LOWER LOOPER LEVER	1	
29	5487	SCREW	1	
30	XXXXXX	LOWER LOOPER	1	
31	1175-2	SCREW	1	
32	212726	THREAD TAKEUP	1	
34	212502	THREAD GUIDE	1	
35	210353	THREAD GUIDE	1	
36	211401	THREAD TAKEUP	1	

See pages 54~75 for ××××××.

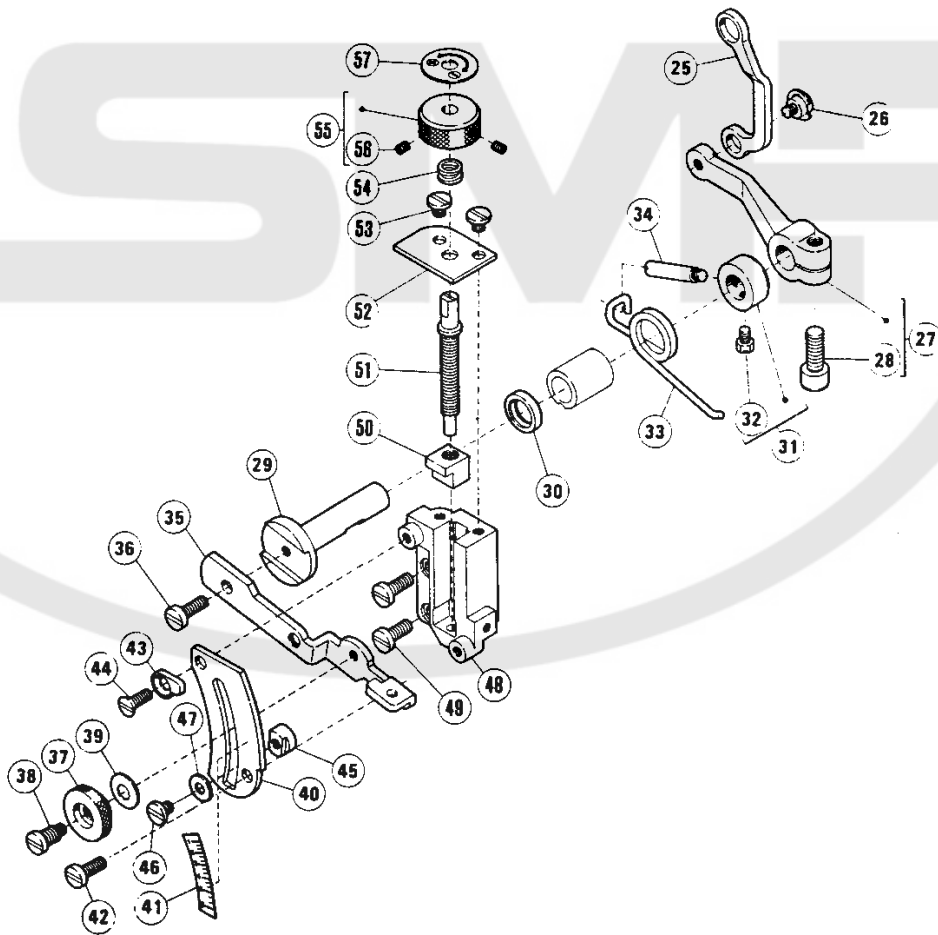
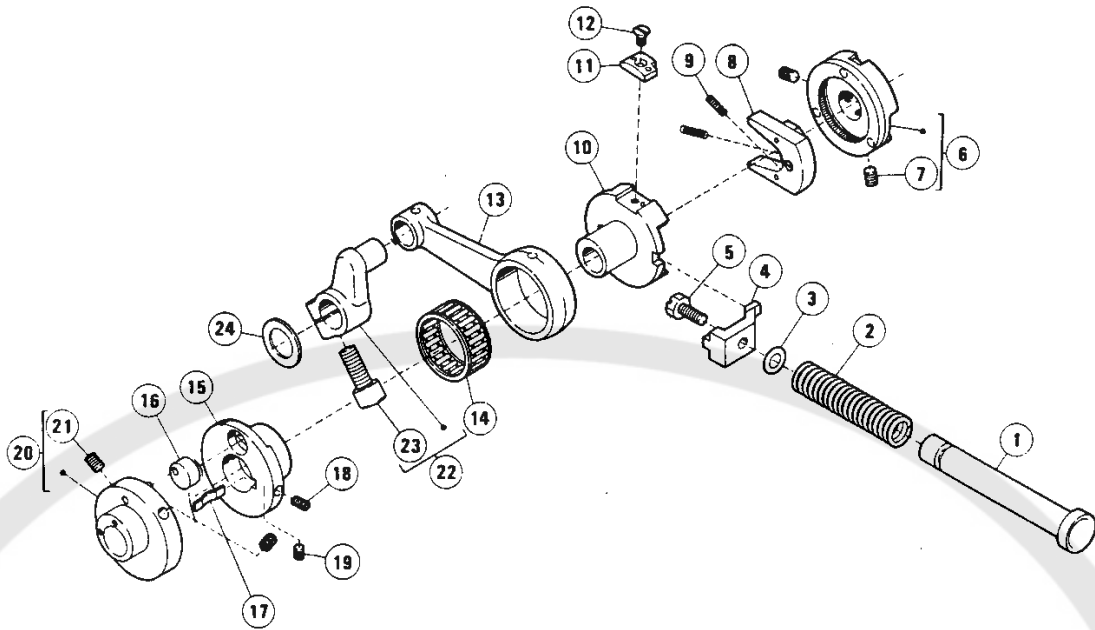

FEED MECHANISM(1)

REF. NO.	PART NO.	NAME	QT.	MEMO
1	210137	PUSH BUTTON	1	
2	210139	SPRING	1	
3	204185	O RING	1	
4	210138	STOPPER	1	
5	2193	SCREW	1	
6	210136	RATCHET WHEEL COMPLETE	1	
7	5461	SCREW	2	
8	208411	FEED REGULATING RATCHET	1	
9	208415	SPRING	2	
10	211802A	ECCENTRIC/FEED REGULATING	1	
11	211804	STOPPER	1	
12	5437	SCREW	1	
13	210140	CONNECTION/FEED DRIVE	1	
14	204084-2	NEEDLE BEARING	1	
15	210127	ECCENTRIC/FEED DRIVE	1	
16	210129	GUDE/FEED ECCENTRIC	1	
17	210130	FLAT SPRING	1	
18	5427	SCREW	1	
19	5292	SCREW	1	
20	210128A	ECCENTRIC RETAINER	1	
21	5461	SCREW	2	
22	210141A	CRANK/FEED DRIVE	1	
23	5457	SCREW	1	
24	208235	WASHER	1	
25	210161	LINK/DIFF. FEED REGULATING	1	
26	5316	SCREW	1	
27	210162	LEVER/DIFF. FEED REGULATING	1	
28	5457	SCREW	1	
29	210163	SHAFT/DIFF. FEED REGULATING	1	
30	204052A	OIL SEAL	1	
31	204754A	COLLAR	1	
32	5084	SCREW	1	
33	204756	SPRING	1	
34	204757	PIN	1	
35	210166	LEVER/DIFF. FEED REGULATING	1	
36	5117	SCREW	1	
37	210167	THUMB NUT	1	
38	5486	SCREW	1	
39	211301	SPRING	1	
40	210168	REGULATING PLATE/DIFF. FEED	1	
41	210170	INDICATION PLATE	1	
42	5117	SCREW	1	
43	210700	STOPPER	1	
44	1732	SCREW	1	
45	210171	STOPPER	1	
46	2905	SCREW	1	
47	201185	WASHER	1	
48	211314	REGULATING BASE/DIFF. FEED	1	
49	5118	SCREW	2	
50	210535	BLOCK/DIFF. FEED REGULATING	1	
51	210172	REGULATING BAR/DIFF. FEED	1	
52	210534	GUIDE/DIFF. FEED REG. BAR	1	
53	5091	SCREW	2	
54	210533	SPRING	1	
55	210532	THUMB NUT	1	
56	5292	SCREW	2	
57	212179	MARK	1	

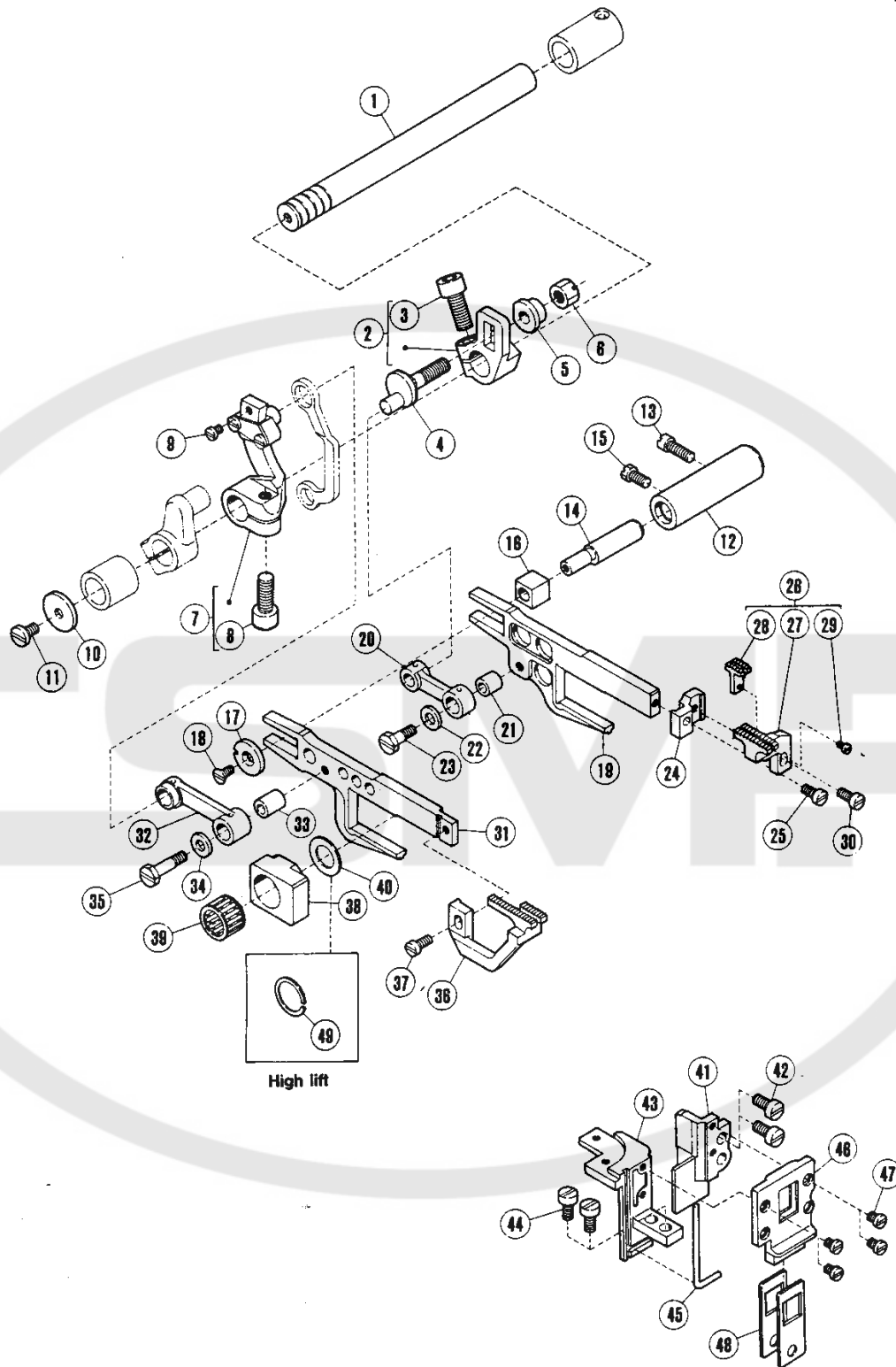

FEED MECHANISM(2)

REF. NO.	PART NO.	NAME	QT.	MEMO
1	212028	FEED SHAFT	1	
2	210144	CRANK/MAIN FEED	1	
3	5457	SCREW	1	
4	210145	PIN	1	
5	210146	WASHER	1	
6	5455	NUT	1	
7	210152	CRANK COMPLETE/DIFF. FEED	1	
8	5457	SCREW	1	
9	5346	SCREW	1	
10	210100	WASHER	1	
11	4009-1	SCREW	1	
12	204129A	BUSHING	1	
13	2133-1	SCREW	1	
14	204128A	PIN	1	
15	5084	SCREW	1	
16	205418	BLOCK/FEED BAR GUIDE	1	
17	204439A	WASHER	1	
18	5317	SCREW	1	
19	210154	MAIN FEED BAR	1	
20	210147	LINK/MAIN FEED	1	
21	210148	BUSHING	1	
22	204115	WASHER	1	
23	5489	SCREW	1	
24	210343	BRACKET/MAIN FEED DOG	1	
25	1175-2	SCREW	1	
26	XXXXXX	MAIN FEED DOG COMPLETE	1	
27	XXXXXX	MAIN FEED DOG	1	
28	XXXXXX	AUXILIARY FEED DOG	1	
29	5492	SCREW	1	
30	1175-2	SCREW	1	
31	210155	DIFFERENTIAL FEED BAR	1	
32	210153	LINK/DIFFERENTIAL FEED	1	
33	204114	BUSHING	1	
34	204115	WASHER	1	
35	5231	SCREW	1	
36	XXXXXX	DIFFERENTIAL FEED DOG	1	
37	1175-2	SCREW	1	
38	210156	BLOCK	1	
39	206128-2	NEEDLE BEARING	1	
40	208235	WASHER	1	
41	210157	GUIDE (RIGHT)/FEED BAR	1	
42	5205	SCREW	2	
43	210158	GUIDE (LEFT)/FEED BAR	1	
44	2902	SCREW	2	
45	208168	GASKET	1	
46	210160	GUIDE/FEED BAR OIL SEAL	1	
47	5346	SCREW	4	
48	210159	OIL SEAL	2	
49	206129	RING	1	

See pages 54~75 for XXXXXX.

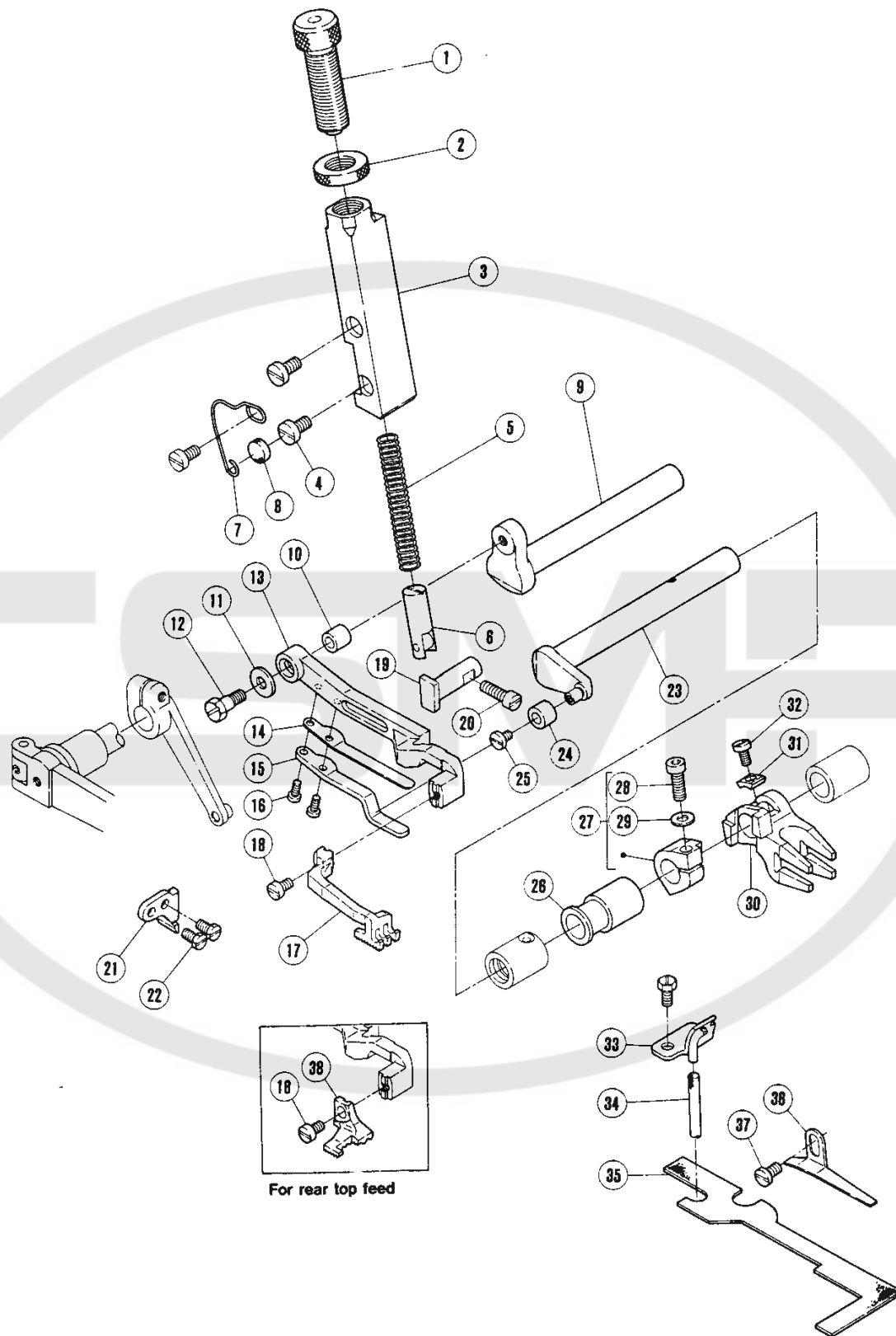

TOP FEED MECHANISM(1)

REF. NO.	PART NO.	NAME	QT.	MEMO
1	212440	THUMB SCREW	1	
2	210328	ADJUSTING SCREW NUT	1	
3	212025	PRESSER BAR GUIDE	1	
4	5117	SCREW	2	
5	212026	SPRING	1	
6	212021	PRESSER BAR COMPLETE	1	
7	212145	SPRING	1	
8	212144	FELT	1	
9	212036	SHAFT	1	
10	210148	BUSHING	1	
11	204115	WASHER	1	
12	5489	SCREW	1	
13	212400	TOP FEED BAR	1	
14	212448	PLATE (UPPER)	1	
15	212449	PLATE (LOWER)	1	
16	5492	SCREW	2	
17	XXXXXX	TOP FEED DOG	1	
18	1175-2	SCREW	1	
19	212019	GUIDE (RIGHT)	1	
20	2133-1	SCREW	1	
21	212020	GUIDE (LEFT)	1	
22	5238	SCREW	2	
23	212404	ROD	1	
24	212015	ROLLER	1	
25	5597	SCREW	1	
26	212405	SPACER	1	
27	212447	LATCH	1	
28	5568	SCREW	1	
29	307003	WASHER	1	
30	212445	CRANK	1	
31	212446	CRANK GUIDE	1	
32	5089	SCREW	1	
33	212140	OIL PIPE ASSEMBLY	1	
34	212143	FELT	1	
35	212146	FELT	1	
36	212147	FELT RETAINER	1	
37	2905	SCREW	1	
38	XXXXXX	TOP FEED DOG	1	

See pages 54~75 for ××××××.

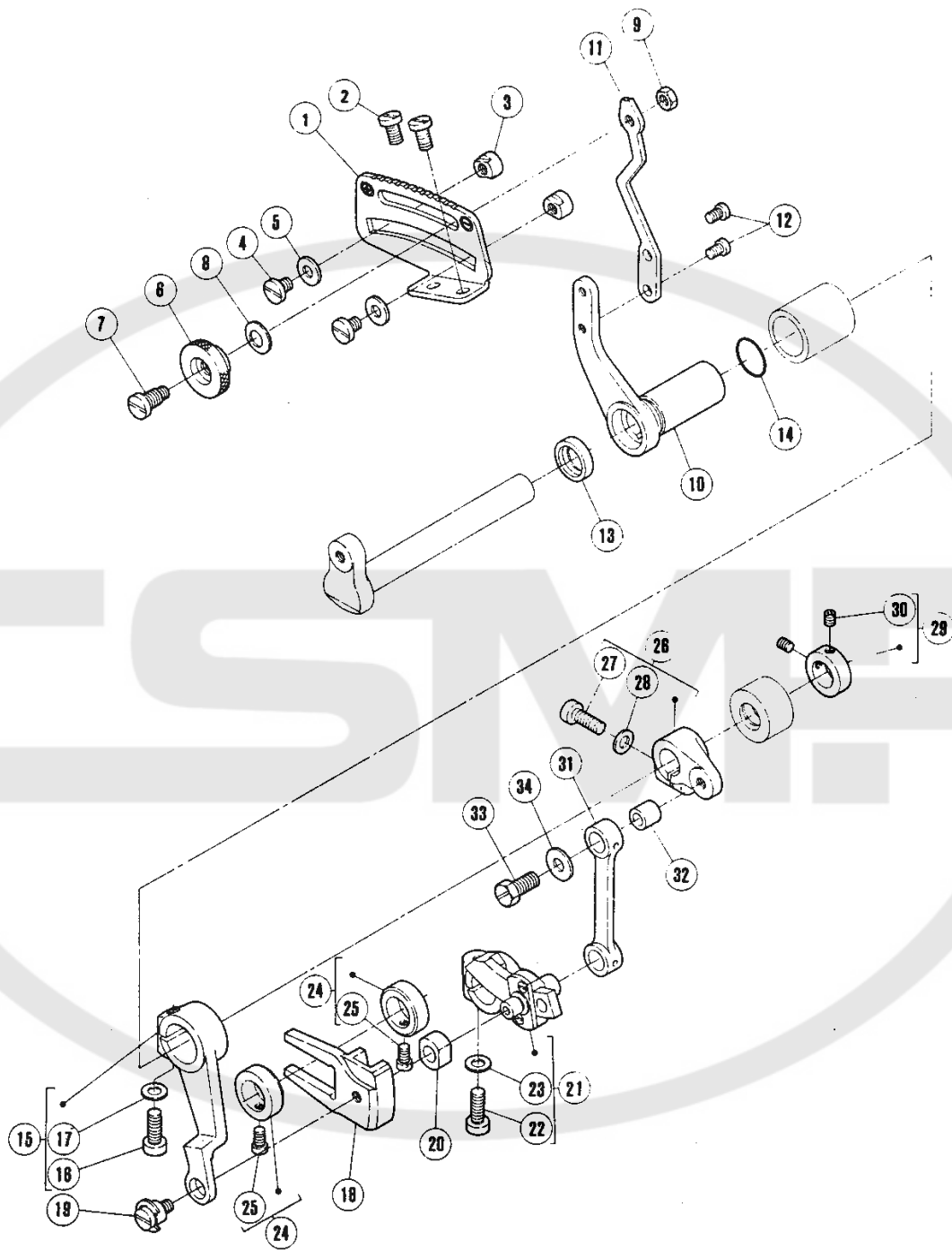

TOP FEED MECHANISM(2)

REF. NO.	PART NO.	NAME	QT.	MEMO
1	212416	BLADE GUIDE	1	
2	5117	SCREW	2	
3	210171	STOPPER	2	
4	2905	SCREW	2	
5	201185	WASHER	2	
6	210167	THUMB NUT	1	
7	5486	SCREW	1	
8	211301	SPRING	1	
9	3044	NUT	1	
10	212042	LEVER	1	
11	212419	LEVER	1	
12	5053	SCREW	2	
13	204052A	OIL SEAL	1	
14	201022	O RING	1	
15	212652	LEVER	1	
16	5594	SCREW	1	
17	307003	WASHER	1	
18	212651	GUIDE/BLOCK	1	
19	5316	SCREW	1	
20	252531	BLOCK	1	
21	212646	CRANK ASSEMBLY	1	
22	5594	SCREW	1	
23	307003	WASHER	1	
24	212653	COLLAR	2	
25	1998-2	SCREW	2	
26	212035	CRANK	1	
27	5594	SCREW	1	
28	307003	WASHER	1	
29	212039	COLLAR	1	
30	5292	SCREW	2	
31	212650	LINK	1	
32	210148	BUSHING	1	
33	5489	SCREW	1	
34	204115	WASHER	1	

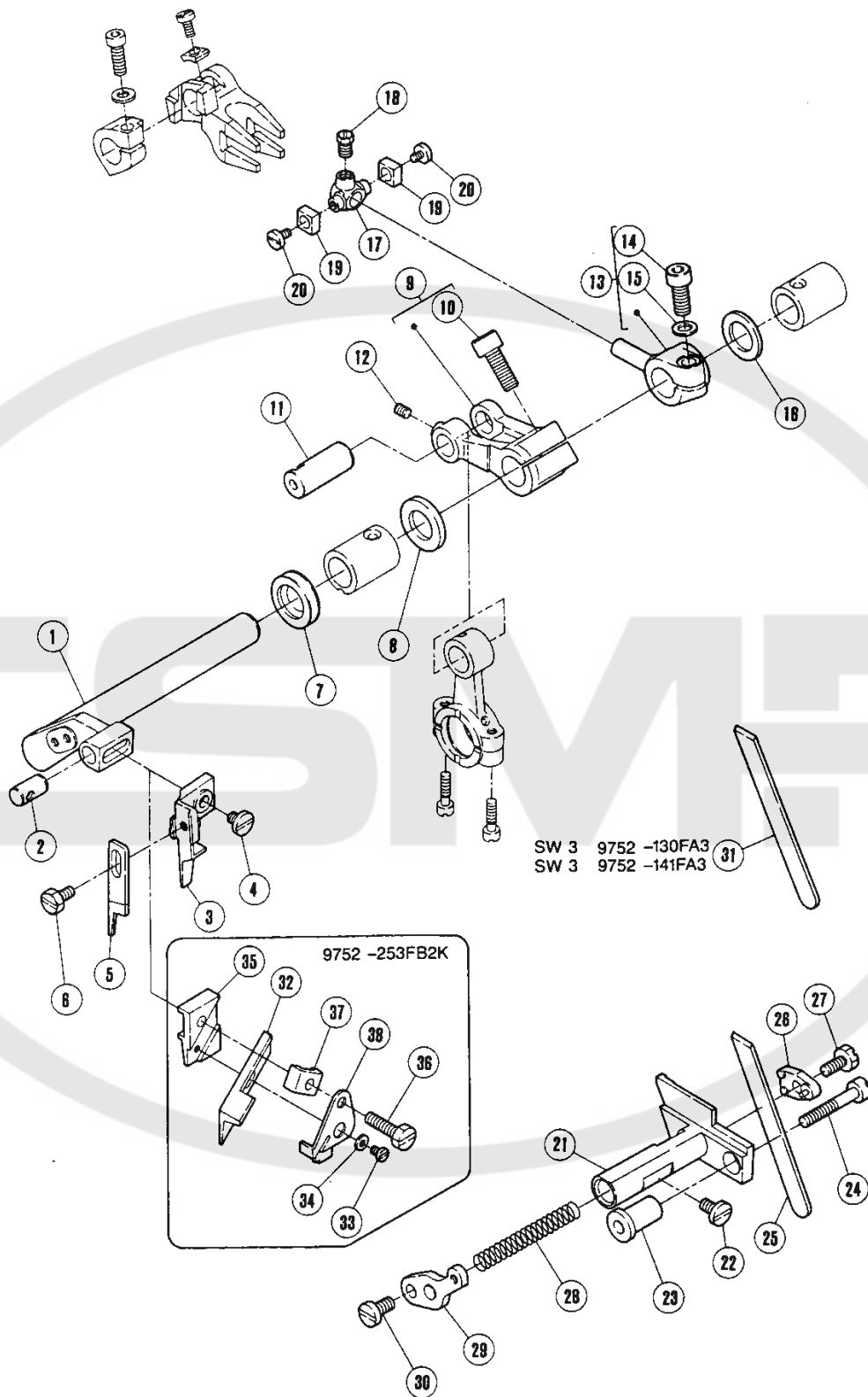

SW-SEAM WIDTH

KNIFE DRIVE MECHANISM

REF. NO.	PART NO.	NAME	QT.	MEMO
1	213222A	UPPER KNIFE LEVER	1	
2	208579	PIN	1	
3	210178A	UPPER KNIFE CLAMP	1	
4	2902	SCREW	1	
* 5	201121A	UPPER KNIFE	1	
6	5088	SCREW	1	
7	210069	OIL SEAL	1	
8	206180	WASHER	1	
9	210314	CRANK/UPPER KNIFE DRIVE	1	
10	5457	SCREW	1	
11	210175	PIN	1	
12	5461	SCREW	1	
13	212408	CRANK	1	
14	5594	SCREW	1	
15	307003	WASHER	1	
16	208235	WASHER	1	
17	212409	PIN	1	
18	5084	SCREW	1	
19	212410	BLOCK	2	
20	5597	SCREW	2	
21	210179	LOWER KNIFE HOLDER	1	
22	4009-1	SCREW	1	
23	210180	GUIDE/LOWER KNIFE HOLDER	1	
24	5094	SCREW	1	
25	202295	LOWER KNIFE/THICK	1	
26	210184	CLAMP/LOWER KNIFE	1	
27	2193	SCREW	1	
28	202340	SPRING	1	
29	210183	SPRING RETAINER	1	
30	5117	SCREW	1	
*31	201127	LOWER KNIFE/THIN	1	
32	211771	ANGLED KNIFE	1	
33	1227	SCREW	1	
34	300248	WASHER	1	
35	210756	ANGLED UPPER KNIFE CLAMP	1	
36	5504	SCREW	1	
37	210758	ANGLED UPPER KNIFE GIB	1	
38	210759	ANGLED UPPER KNIFE PLATE	1	

Notice) Parts with mark * are not for sale.

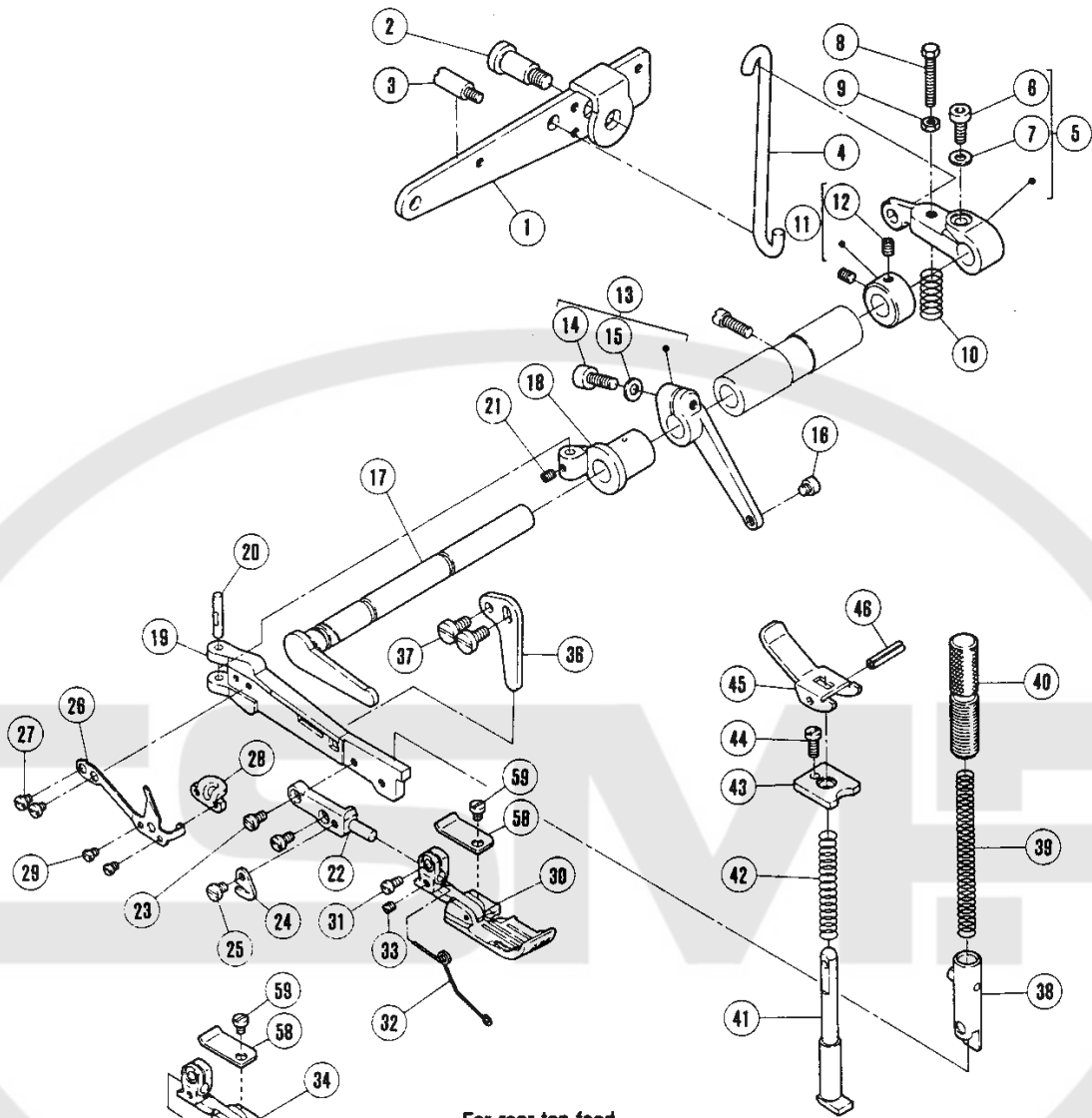

For rear top feed

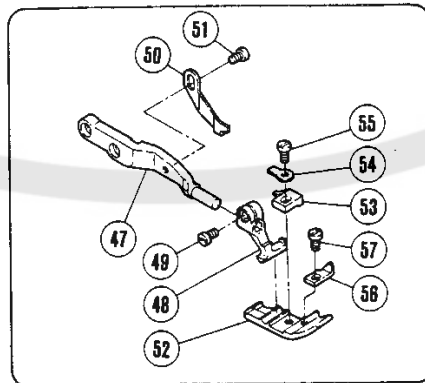

PRESSER FOOT MECHANISM

REF. NO.	PART NO.	NAME	QT.	MEMO
1	211636	LEVER/FOOT LIFT	1	
2	2285B	SCREW	1	
3	5481	SCREW	1	
4	210335	LINK/FOOT LIFT LEVER	1	
5	212050	LEVER/FOOT LIFT	1	
6	5457	SCREW	1	
7	207924	WASHER	1	
8	5503	SCREW	1	
9	3044	NUT	1	
10	240172	SPRING	1	
11	210728	COLLAR	1	
12	5292	SCREW	2	
13	212052	LEVER/FOOT LIFT	1	
14	5594	SCREW	1	
15	307003	WASHER	1	
16	5596	SCREW	1	
17	212047	SHAFT/FOOT LIFT	1	
18	212049	HINGE/PRESSER ARM	1	
19	211823	PRESSER ARM	1	
20	210323	PIN	1	
21	5292	SCREW	1	
22	212420	BRACKET/PRESSER FOOT	1	
23	5089	SCREW	2	
24	202451	CHAIN CUTTER	1	
25	2921	SCREW	1	
26	212438	FLAT SPRING	1	
27	5299	SCREW	2	
28	212439	GUIDE	1	
29	5030	SCREW	2	
30	XXXXXX	PRESSER FOOT	1	
31	5328	SCREW	1	
32	212669A	SPRING	1	
33	1459	SCREW	1	
34	XXXXXX	PRESSER FOOT	1	
35	212719A	SPRING	1	
36	210517	STOPPER/PRESSER ARM	1	
37	5117	SCREW	1	
38	208537	PRESSER BAR COMPLETE	1	
*39	211941	SPRING	1	
40	208774	THUMB SCREW	1	
41	202645	PLUNGER	1	
42	201395	SPRING	1	
43	208599	BUSHING	1	
44	5029	SCREW	1	
45	211657	LEVER/HAND LIFT	1	
46	202647A	PIN	1	
47	212705	BRACKET/PRESSER FOOT	1	
48	208525-B	BRACKET/PRESSER FOOT	1	
49	5328	SCREW	1	
50	212069	STOPPER	1	
51	2921	SCREW	1	
52	XXXXXX	PRESSER FOOT	1	
53	XXXXXX	PRESSER FOOT FINGER	1	
54	201156	SET PLATE/PRESSER FOOT	1	
55	5089	SCREW	1	
56	211557	FABRIC GUARD	1	
57	1333	SCREW	1	
58	212668	EUXILIARY PLATE	1	
59	5030	SCREW	1	

Notice) Parts with mark * are not for sale.

See pages 54~75 for XXXXXX.

■ PLEASE NOTE:

The machines (after the machine number 8613662)
which are manufactured from July, 1987.

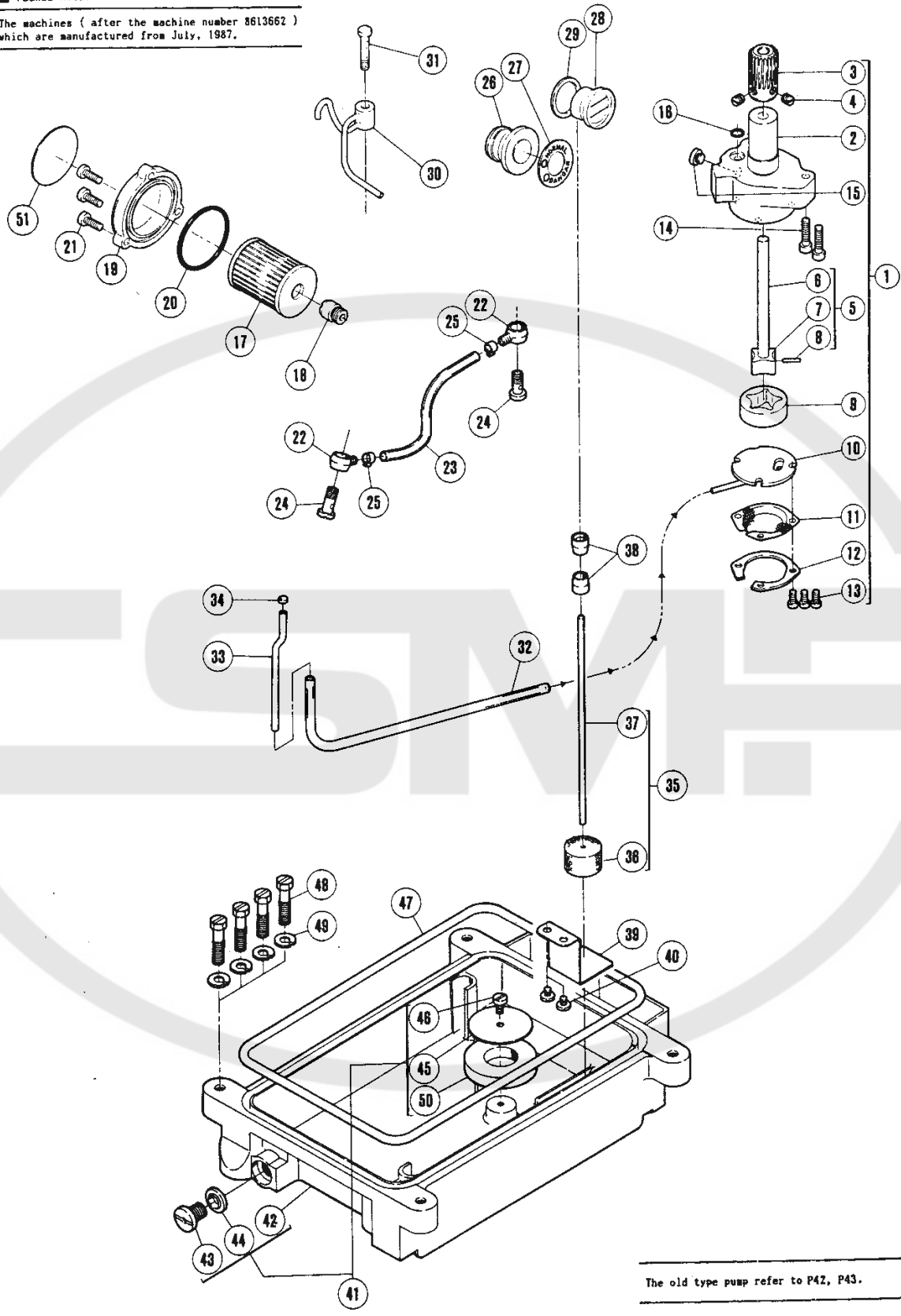

The old type pump refer to P42, P43.

LUBRICATING MECHANISM

REF. NO.	PART NO.	NAME	QT.	MEMO
1	212972A91	TROCHOID PUMP ASSEMBLY	1	
* 2	212976	TROCHOID PUMP	1	
3	211531	WORM WHEEL	1	
4	5060	SCREW	2	
5	212978-91	ROTOR (INSIDE) SHAFT	1	
* 6	212979	SHAFT	1	
* 7	212980	ROTOR (INSIDE)	1	
* 8	206468	PIN	1	
9	212981	ROTOR (OUTSIDE)	1	
10	212983-91	PLATE	1	
11	213578A	FILTER	1	
12	213579	GUIDE	1	
13	1175-2	SCREW	3	
14	5095	SCREW	2	
15	5145	SCREW	1	
16	204185	O RING	1	
17	206233	OIL FILTER	1	
18	210200	BRACKET/OIL FILTER	1	
19	210201-CD	OIL FILTER CAP	1	
20	206431	O RING	1	
21	5118	SCREW	3	
22	200136	JOINT	2	
23	205113A	OIL TUBE	1	
24	200152	JOINT SCREW	2	
25	202199	CLAMP	2	
26	210198	OIL MONITOR COMPLETE	1	
27	210199	NAME PLATE/OIL MONITOR	1	
28	210190	OIL SIGHT GAUGE	1	
29	211369	WASHER	1	
30	212188	OIL DISTRIBUTOR	1	
31	212998	JOINT SCREW	1	
32	212152	TUBE	1	
33	212153	PIPE	1	
34	303487	FELT	1	
35	210193	INDICATOR COMPLETE	1	
*36	179257-05	FLOAT	1	
*37	210192	INDICATOR	1	
38	210194	INDICATOR GUIDE	2	
*39	210510	INDICATOR SUPPORT	1	
40	2905	SCREW	2	
41	212634	OIL RESERVOIR COMPLETE	1	
42	210211	OIL RESERVOIR	1	
43	5138B	SCREW	1	
44	202287A	GASKET	1	
45	210521	MAGNET BRACKET	1	
46	5117	SCREW	1	
47	210212	O RING	1	
48	5113	SCREW	4	
49	202045	SPRING WASHER	4	
50	210520	MAGNET	1	
51	9A3002	FILTER SEAL	1	

Notice) Parts with mark * are not for sale.

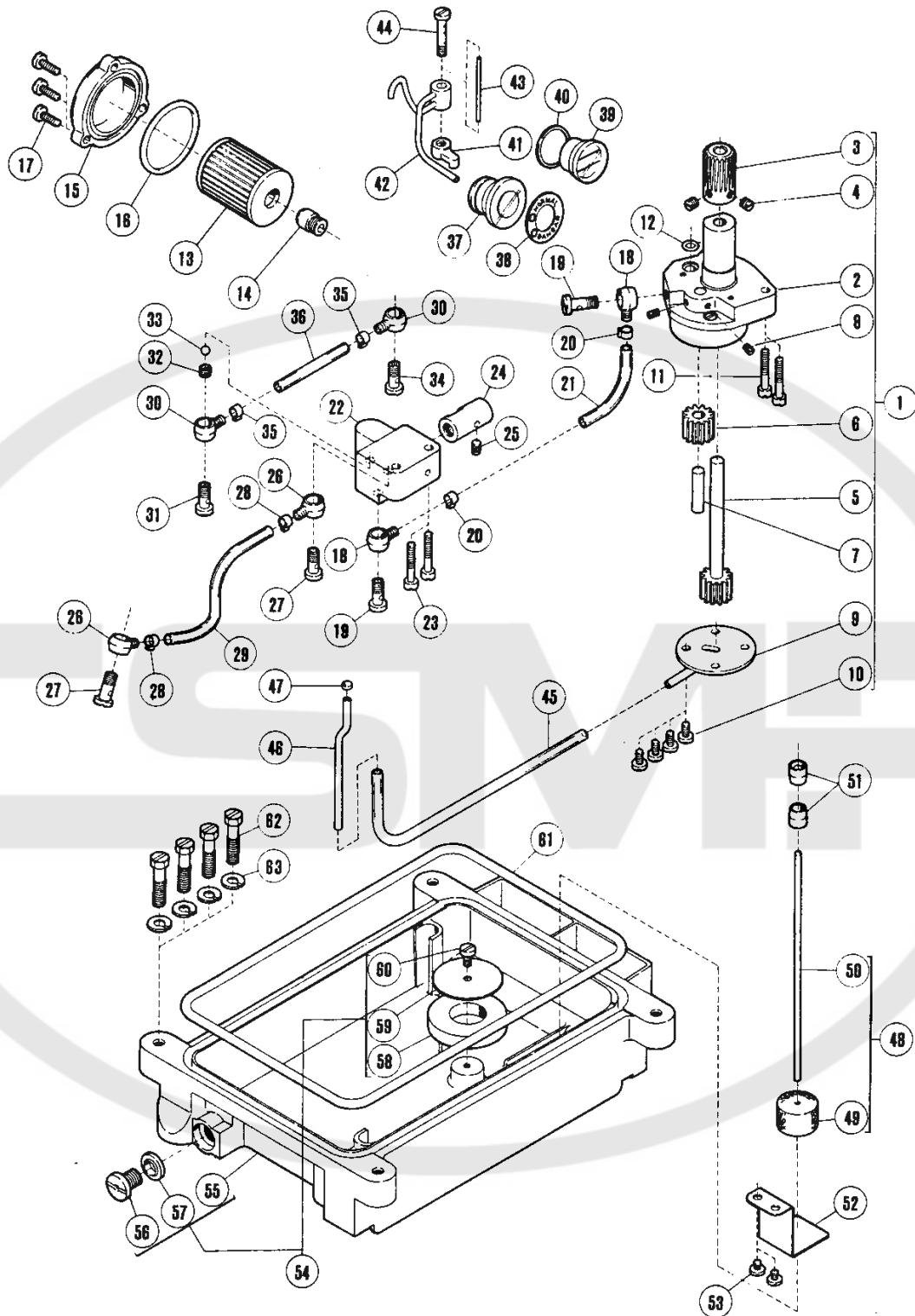

LUBRICATING MECHANISM (OLD TYPE)

REF. NO.	PART NO.	NAME	QT.	MEMO
1	212148	OIL PUMP ASSEMBLY	1	
* 2	210188	GEAR PUMP	1	
3	211531	WORM WHEEL	1	
4	5060	SCREW	2	
5	208687	GEAR	1	
6	201295	GEAR	1	
7	204184	GEAR SHAFT	1	
8	1458	SCREW	2	
* 9	212149	CASING PLATE	1	
10	5117	SCREW	4	
11	5095	SCREW	2	
12	204185	O RING	1	
13	206233	OIL FILTER	1	
14	210200	BRACKET/OIL FILTER	1	
15	210201-FD	OIL FILTER CAP	1	
16	206431	O RING	1	
17	5118	SCREW	3	
18	200136	JOINT	2	
19	200152	JOINT SCREW	2	
20	202199	CLAMP	2	
21	210701	OIL TUBE	1	
22	210206	BY-PASS BLOCK	1	
23	5095	SCREW	2	
24	205635	BY-PASS VALVE ASSEMBLY	1	
25	1458	SCREW	1	
26	200136	JOINT	2	
27	200152	JOINT SCREW	2	
28	202199	CLAMP	2	
29	205763	OIL TUBE	1	
30	200136	JOINT	2	
31	200152	JOINT SCREW	1	
32	210744	POST	1	
33	200144	BALL	1	
34	200152	JOINT SCREW	1	
35	202199	CLAMP	2	
36	210208	TUBE	1	
37	210198	OIL MONITOR COMPLETE	1	
38	210199	NAME PLATE/OIL MONITOR	1	
39	210190	OIL SIGHT GAUGE	1	
40	211369	WASHER	1	
41	210202	LUBRICATION BLOCK	1	
42	212188	OIL DISTRIBUTOR	2	
43	210205	PIN	1	
44	210204	JOINT SCREW	1	
45	212152	TUBE	1	
46	212153	PIPE	1	
47	303487	FELT	1	
48	210193	INDICATOR COMPLETE	1	
*49	210191	FLOAT	1	
*50	210192	INDICATOR	1	
51	210194	INDICATOR GUIDE	2	
*52	210510	INDICATOR SUPPORT	1	
53	2905	SCREW	2	
54	212634	OIL RESERVOIR COMPLETE	1	
55	210211	OIL RESERVOIR	1	
56	5138B	SCREW	1	
57	202287A	GASKET	1	
58	210520	MAGNET	1	
59	210521	MAGNET BRACKET	1	
60	5117	SCREW	1	
61	210212	O RING	1	
62	5113	SCREW	4	
63	202045	SPRING WASHER	4	

Notice) Parts with mark * are not for sale.

H.R. DEVICE

REF. NO.	PART NO.	NAME	QT.	MEMO
1	210213	NEEDLE COOLER	1	
2	210214	PLUG	1	
3	5091	SCREW	2	
4	204466	OIL WICK	1	
* 5	210766	PIN	1	
6	210215	BRACKET/NEEDLE COOLER	1	
7	5012	SCREW	2	
8	211639	OIL TUBE	1	
9	200155	TUBE CLAMP	2	
*10	202176	OIL WICK	1	
11	210539	SILICONE OIL RESERVOIR (LOWER)	1	
12	5345	SCREW	1	
13	201185	WASHER	1	

Notice) Parts with mark * are not for sale.

- 1 9752 -FD
- 2 9752 -FD4/P1,P2

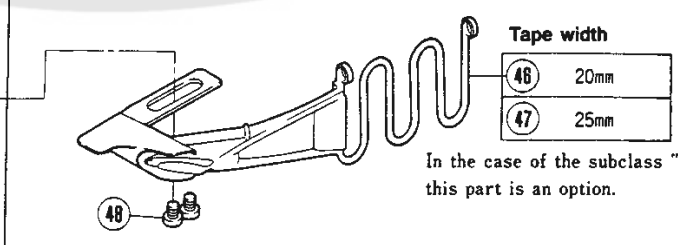
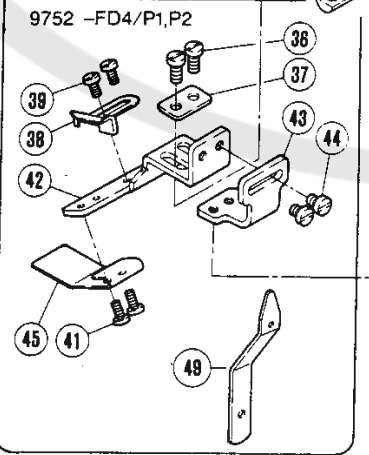
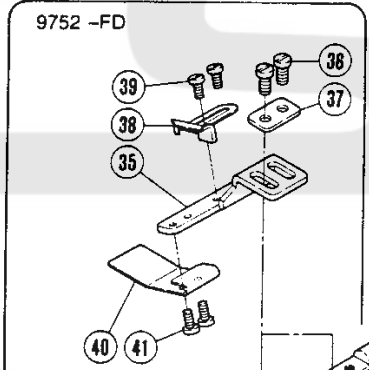
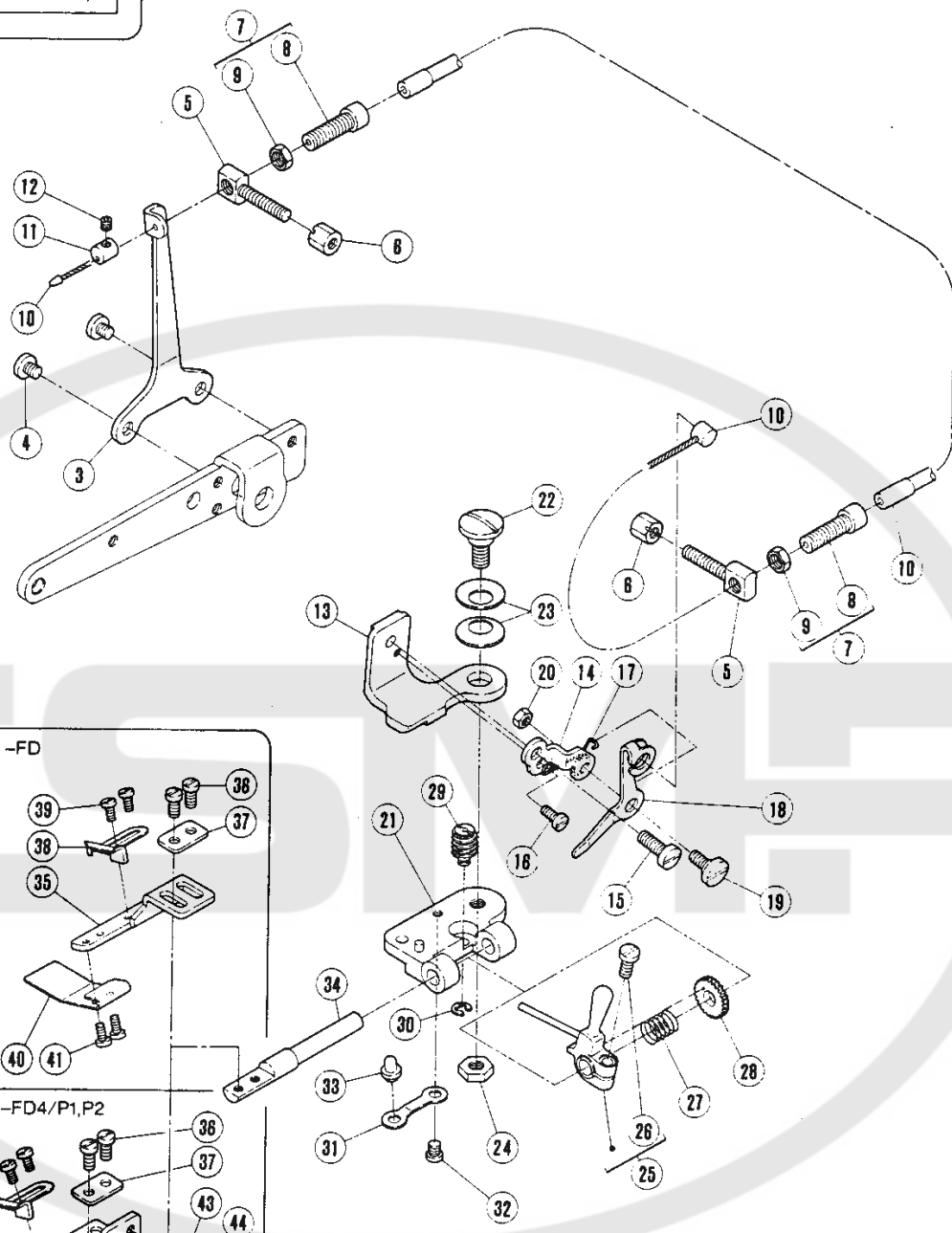

In the case of the subclass "P1" this part is an option.

SHIRRING ATTACHMENT

REF. NO.	PART NO.	NAME	QT.	MEMO
1	212655	SHIRRING ATTACHMENT COMPLETE	1	
2	212655A91	SHIRRING ATTACHMENT COMPLETE	1	
3	212433	LEVER	1	
4	2905	SCREW	2	
5	212437	BRACKET	2	
6	5111	SCREW	2	
7	212436	CABLE SUPPORT	2	
* 8	212477	CABLE SUPPORT	2	
9	4806	NUT	2	
10	212435	CABLE	1	
11	212434	STOPPER	1	
12	1459	SCREW	1	
13	212600	BRACKET	1	
14	212430	BRACKET	1	
15	5118	SCREW	1	
16	5328	SCREW	1	
17	212432	SPRING	1	
18	212431	LEVER	1	
19	5515	SCREW	1	
20	3091	NUT	1	
21	212601	BRACKET	1	
22	5380	SCREW	1	
23	204888	SPRING	2	
24	5104	NUT	1	
25	212604	LEVER	1	
26	1175-2	SCREW	1	
27	212606	SPRING	1	
28	212607	GEAR	1	
29	212602	WORM	1	
30	200555	RING	1	
31	210684	FLAT SPRING	1	
32	1234	SCREW	1	
33	210683	PIN	1	
34	212603	ROD	1	
35	212659	BRACKET	1	
36	1196	SCREW	2	
37	210955	WASHER	1	
38	212660	CLOTH GUIDE	1	
39	5077	SCREW	2	
40	212658	SHIRRING BLADE	1	
41	5077	SCREW	2	
42	212938	BRACKET	1	
43	212939	BRACKET	1	
44	2921	SCREW	2	
45	212658A	SHIRRING BLADE	1	
46	211880	BINDER (20)	1	
47	211946	BINDER (25)	1	
48	2921	SCREW	2	
49	211949	CORD GUIDE PLATE	1	

Notice) Parts with mark * are not for sale.

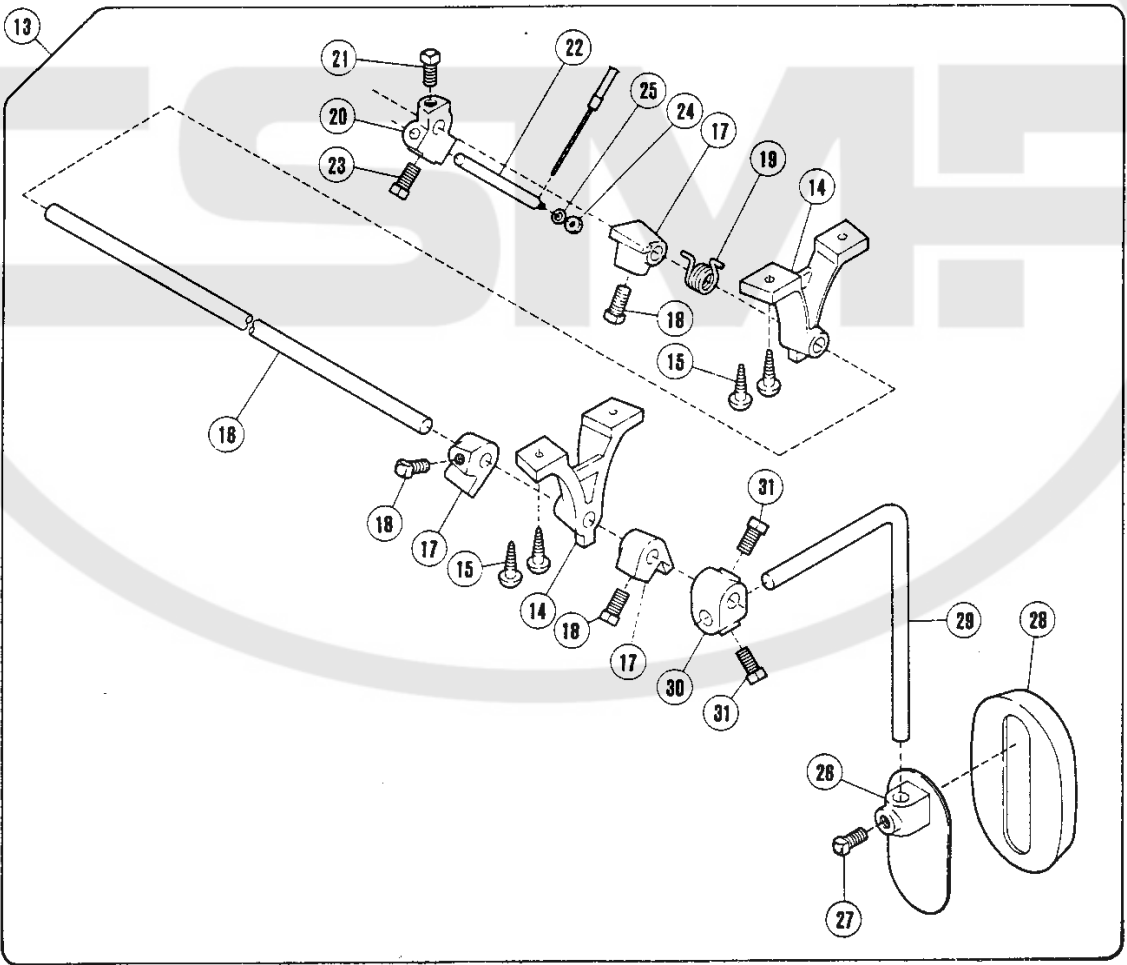
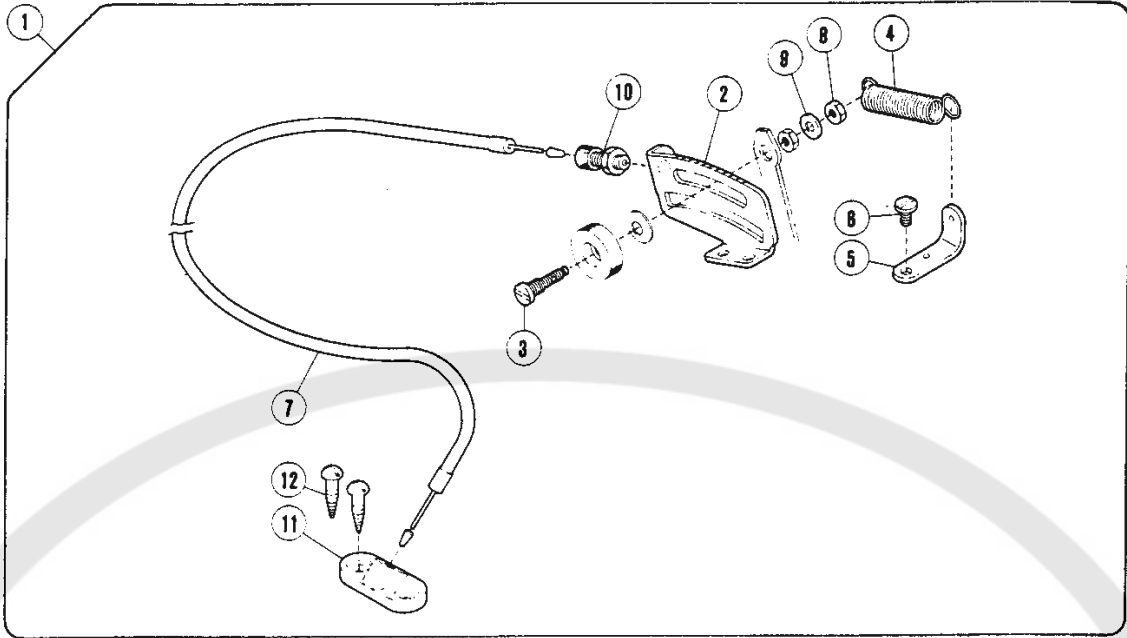

KL DEVICE (MANUAL TYPE)

REF. NO.	PART NO.	NAME	QT.	MEMO
1	212478	INTERMITTENT ATTACHMENT	1	
2	212479	BLADE GUIDE	1	
3	212480	SCREW	1	
4	212481	SPRING	1	
5	212482	LATCH	1	
6	4009-1	SCREW	1	
7	212483	CABLE	1	
8	3044	NUT	1	
9	204585	WASHER	1	
10	212436	CABLE SUPPORT	1	
11	212484	BRACKET	1	
12	4906	SCREW	2	
13	212487	KNEE LIFTER ASSEMBLY	1	
14	207341-JA	FRAME	2	
15	4906	SCREW	4	
16	212485	ROD	1	
17	207344-JA	COLLAR	3	
18	5543	BOLT	3	
19	209287	SPRING	1	
20	207350-JA	BRACKET	1	
21	5543	BOLT	1	
22	212486	LEVER	1	
23	5543	BOLT	1	
24	4805	NUT	1	
25	202058	WASHER	1	
26	207345-JA	KNEE PAD BASE	1	
27	5543	BOLT	1	
28	207346	KNEE PAD	1	
29	212492	ROD	1	
30	212493-JA	BRACKET	1	
31	5543	BOLT	2	

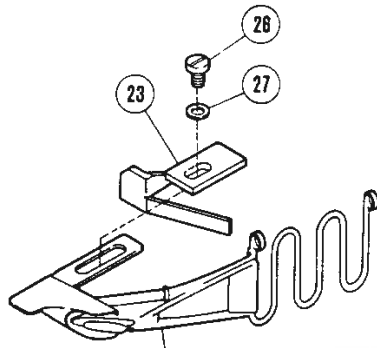

Tape width

20mm	24
25mm	25

In the case of the subclass "P1,"
this part is an option.

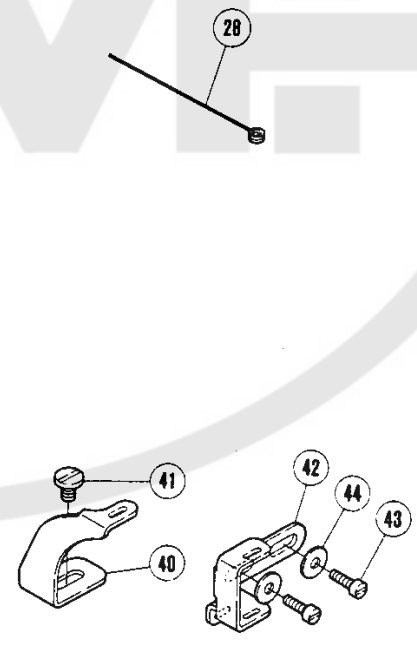
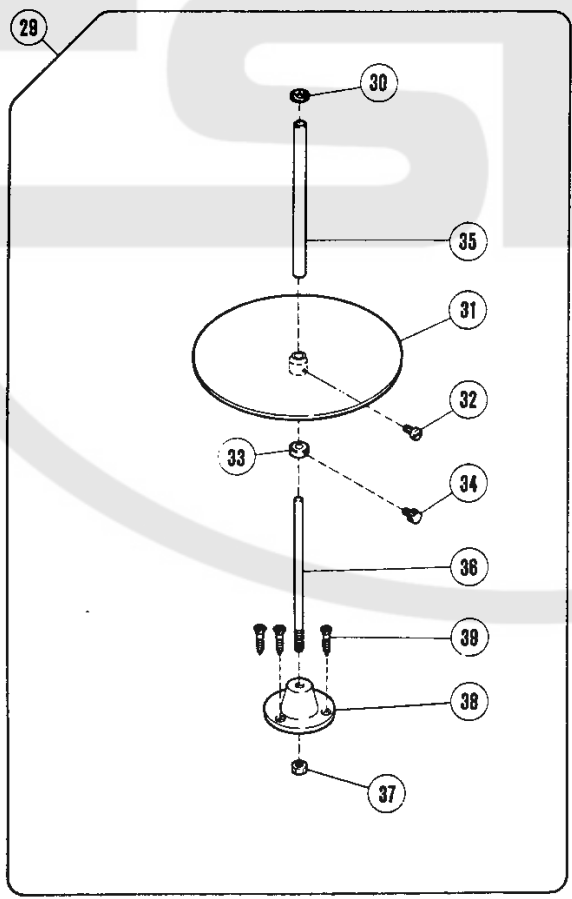
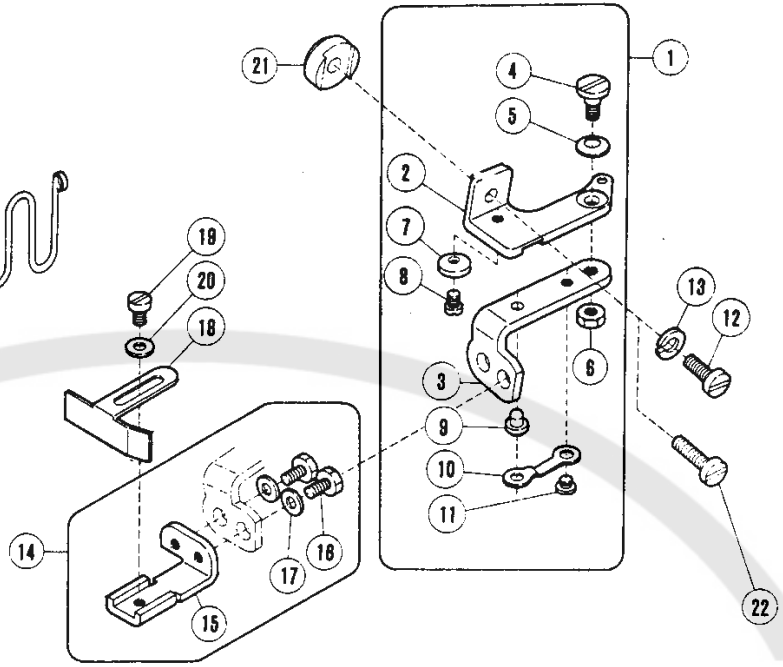

In the case of the subclass "P1,"
this part is an option.

EDGE GUIDE PIPING ATTACHMENT

REF. NO.	PART NO.	NAME	QT.	MEMO
1	210685	CLOTH GUIDE BRACKET ASSEMBLY	1	
2	210680	CLOTH GUIDE BRACKET	1	
3	210681	HINGE/EDGE GUIDE BRACKET	1	
4	5184	SCREW	1	
5	201191	SPRING	1	
6	3044	NUT	1	
7	210682	STOPPER	1	
8	5053	SCREW	1	
9	210683	PIN	1	
10	210684	FLAT SPRING	1	
11	2906	SCREW	1	
12	5118	SCREW	1	
13	202286	SPRING WASHER	1	
14	210686	BRACKET COMPLETE/EDGE GUIDE	1	
15	210687	BRACKET/EDGE GUIDE	1	
16	5088	SCREW	2	
17	167066	WASHER	2	
18	204667	EDGE GUIDE	1	
19	1202	SCREW	1	
20	167066	WASHER	1	
21	212287	SPACER	1	
22	5152	SCREW	1	
23	211879	EDGE GUIDE	1	
24	211880	BINDER (20)	1	
25	211946	BINDER (25)	1	
26	1202	SCREW	1	
27	167066	WASHER	1	
28	413	TAPE INSERTING TOOL	1	
29	403	TAPE DISC ASSEMBLY	1	
30	406	FELT	1	
31	404	TAPE DISC	1	
32	4012	SCREW	1	
33	407	COLLAR	1	
34	408	ADJUSTING SCREW	1	
35	405	FIXING ROD	1	
36	409	SHAFT	1	
37	4818	NUT	1	
38	410-JA	BRACKET	1	
39	4908	SCREW	3	
40	211264	TAPE GUIDE (UPPER)	1	
41	5453	SCREW	1	
42	211265	TAPE GUIDE (LOWER)	1	
43	1174	SCREW	2	
44	167066	WASHER	2	

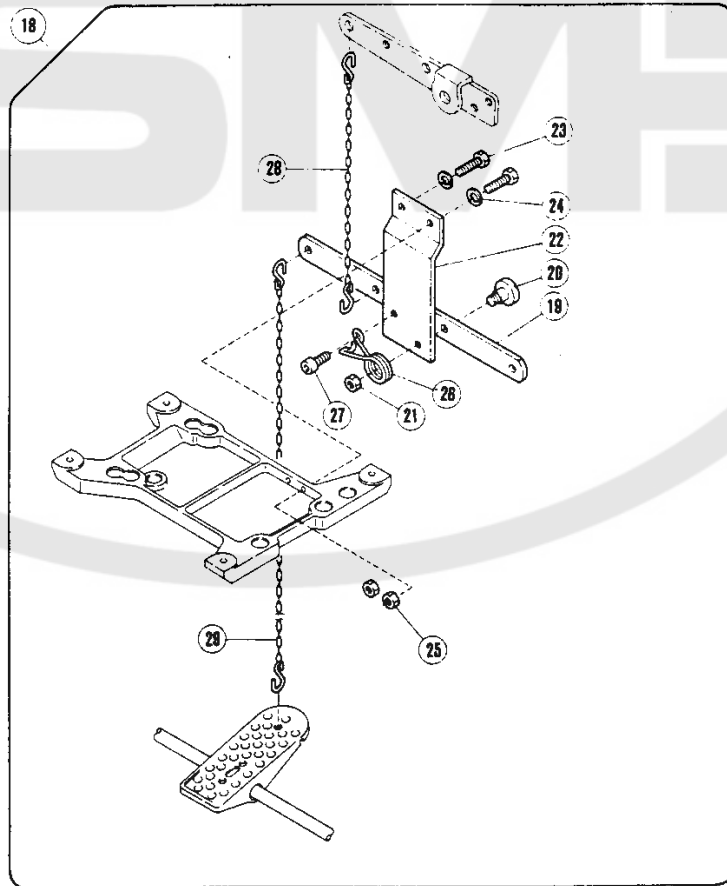
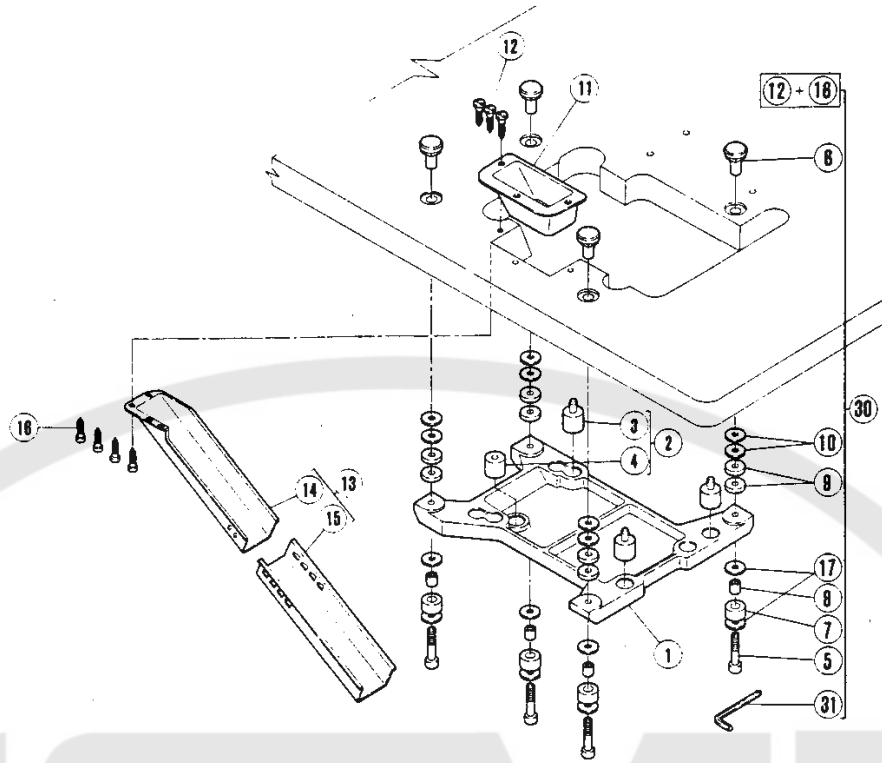

PARTS FOR SEMI-SUBMERGED INSTALLATION

REF. NO.	PART NO.	NAME	QT.	MEMO
1	205466A	MACHINE REST BOARD	1	
2	9029	CUSHION RUBBER (SET)	1	
3	205473	CUSHION RUBBER	3	
4	210523	CUSHION RUBBER	1	
5	4512	SCREW	4	
6	206336	NUT	4	
7	205764	CUSHION RUBBER	4	
8	205765	LINER	4	
9	205467	SPACER	8	
10	206337	WASHER	8	
11	205470-JA	WASTE CHUTE TOP	1	
12	4904	SCREW	3	
13	9050	WASTE CHUTE SET	1	
14	205468-JA	WASTE CHUTE TOP	1	
15	205469-JA	WASTE CHUTE TOP (B)	1	
16	4906	SCREW	4	
17	206337	WASHER	8	
18	212441	FOOT LIFTER ASSEMBLY	1	
19	212442	LEVER	1	
20	5380	SCREW	1	
21	5104	NUT	1	
22	212443	BRACKET	1	
23	5276	SCREW	2	
24	303067	SPRING WASHER	2	
25	5426	NUT	2	
26	212444	SPRING	1	
27	5534	SCREW	1	
28	470	CHAIN	1	
29	471	CHAIN	1	
30	9030	BOLT SET	1	
31	272	ALLEN KEY/6MM	1	

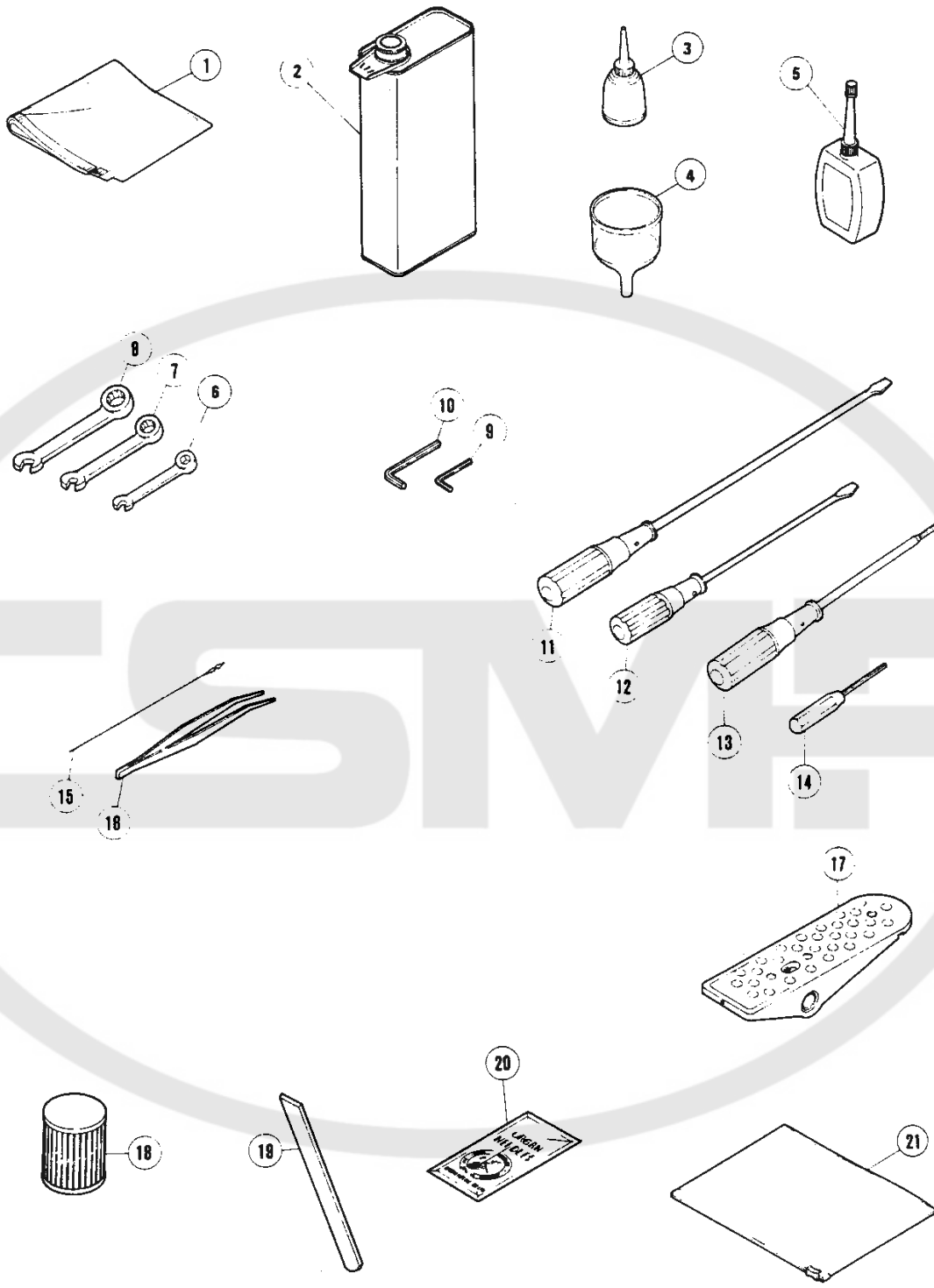

ACCESSORIES

REF. NO.	PART NO.	NAME	QT.	MEMO
1	908	DUST COVER		
2	453	OIL CONTAINER/1000CC		
3	485	OILER		
4	484	OIL FUNNEL		
5	178	CONTAINER - SILICONE		
6	282	WRENCH/5MM		
7	284	WRENCH/7MM		
8	285	WRENCH/8MM		
9	322	ALLEN KEY/2.38MM		
10	200	ALLEN KEY/4.76MM		
11	127	SCREWDRIVER (LARGE)		
12	128	SCREWDRIVER (MEDIUM)		
13	414	ALLEN KEY DRIVER/3.17MM		
14	179	ALLEN KEY DRIVER		
15	153	THREADING WIRE		
16	131	TWEEZERS		
17	480	PEDAL		
18	206233	OIL FILTER		
*19	202295	LOWER KNIFE/THICK		
20	XXXXXX	NEEDLE		
21	482	ACCESSORY BAG		

See pages 54~75 for XXXXXX.

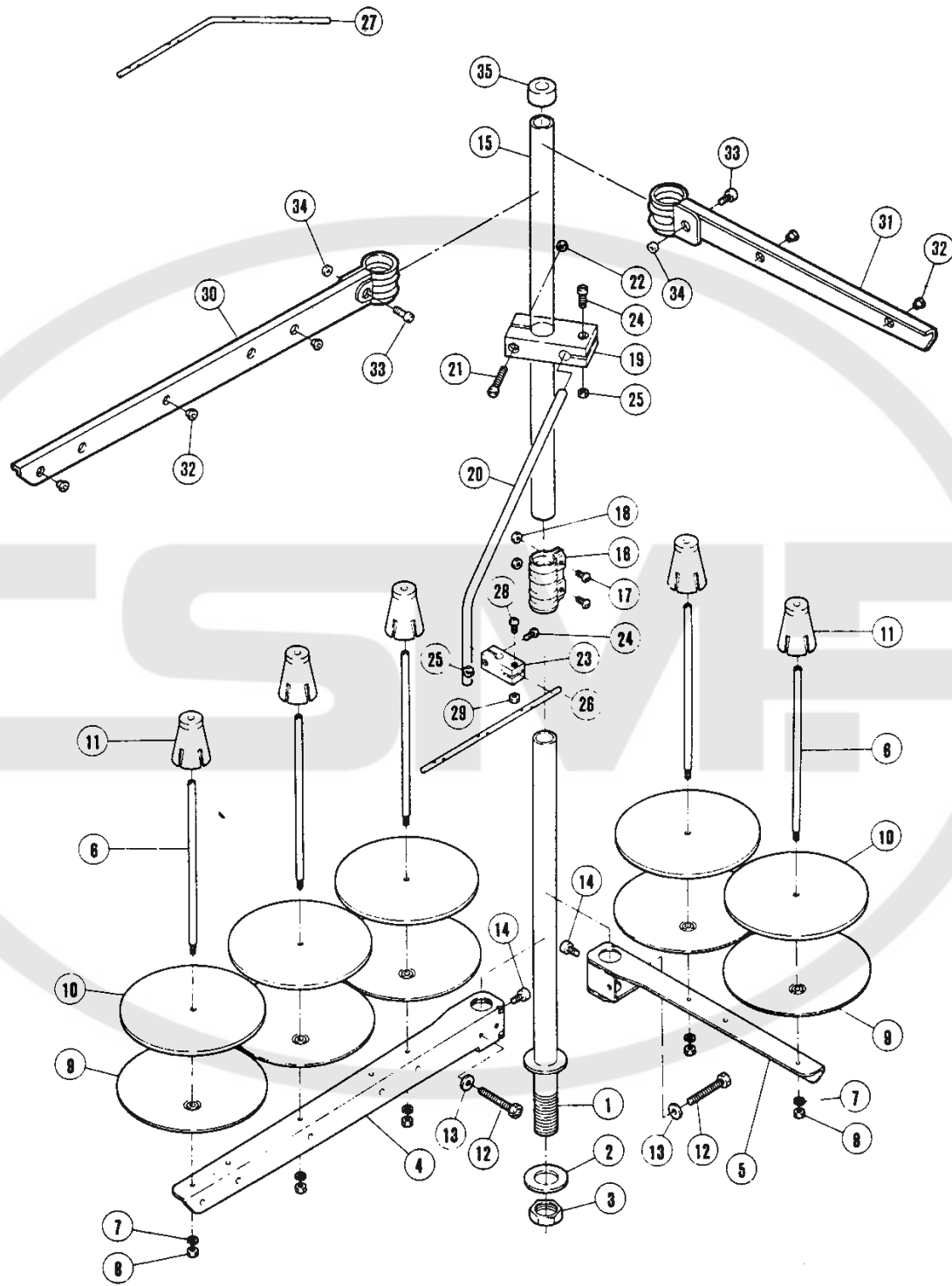

THREAD STAND

REF. NO.	PART NO.	NAME	QT.	MEMO
	486B9C	THREAD STAND ASS. (4-SPOOLS)		1
	486C9C	THREAD STAND ASS. (3-SPOOLS)	1	1
1	503-CA	THREAD STAND ROD (LOWER)	1	1
2	509	WASHER	1	1
3	5476	NUT	1	1
4	505-CA	BRACKET	1	
5	505ACA	BRACKET		2
6	380A	SPOOL PIN	3	4
7	201252	SPRING WASHER	3	4
8	4803	NUT	3	4
9	381-CA	SPOOL TRAY	3	4
10	507	CUSHION	3	4
11	382-CA	SPOOL RETAINING FIN	3	4
12	7102	SCREW	1	2
13	512	WASHER	1	2
14	4022	SCREW	1	2
15	502-CA	THREAD STAND ROD (UPPER)	1	1
16	504-CA	JOINT	1	1
17	4021	SCREW	2	2
18	4805	NUT	2	2
19	383-CA	BRACKET	1	1
20	384	THREAD GUIDE BAR ROD	1	1
21	4014	SCREW	1	1
22	4803	NUT	1	1
23	233-CA	HOLDER	1	1
24	4012	SCREW	2	2
25	4803	NUT	2	2
26	293C	THREAD GUIDE BAR (3-SPOOLS)	1	
27	293B	THREAD GUIDE BAR (4-SPOOLS)		1
28	4012	SCREW	1	1
29	4803	NUT	1	1
30	527-CA	BRACKET	1	
31	527ACA	BRACKET		2
32	506	THREAD EYELET	3	4
33	4117	SCREW	1	2
34	4805	NUT	1	2
35	386	ROD CAP	1	1

9752-186FA2/04-393-W
9752-186AFA2/04-363-W

9752-187FA2/14-393-W
9752-188FB2/14-493-W

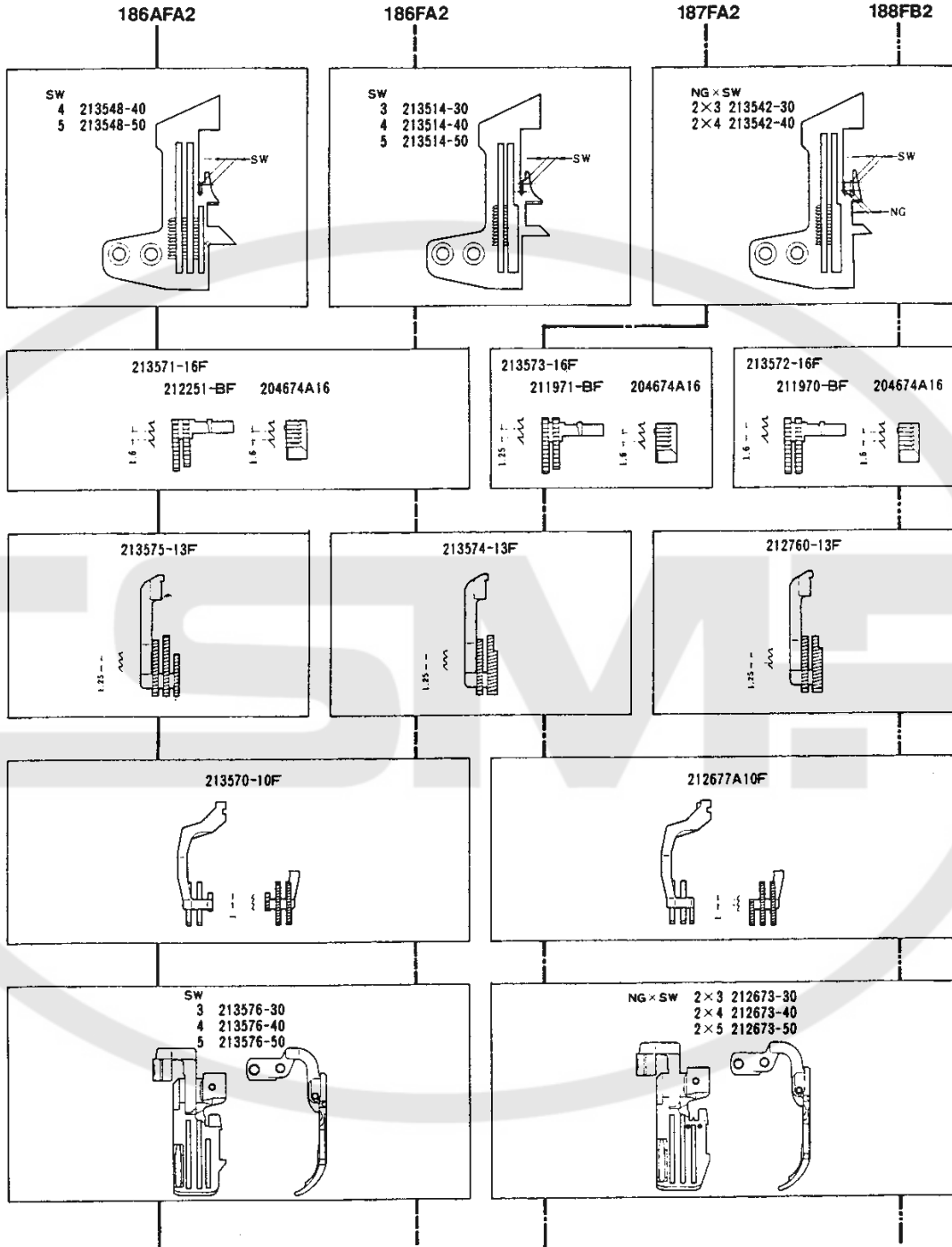

NG-NEEDLE GAUGE
SW-SEAM WIDTH

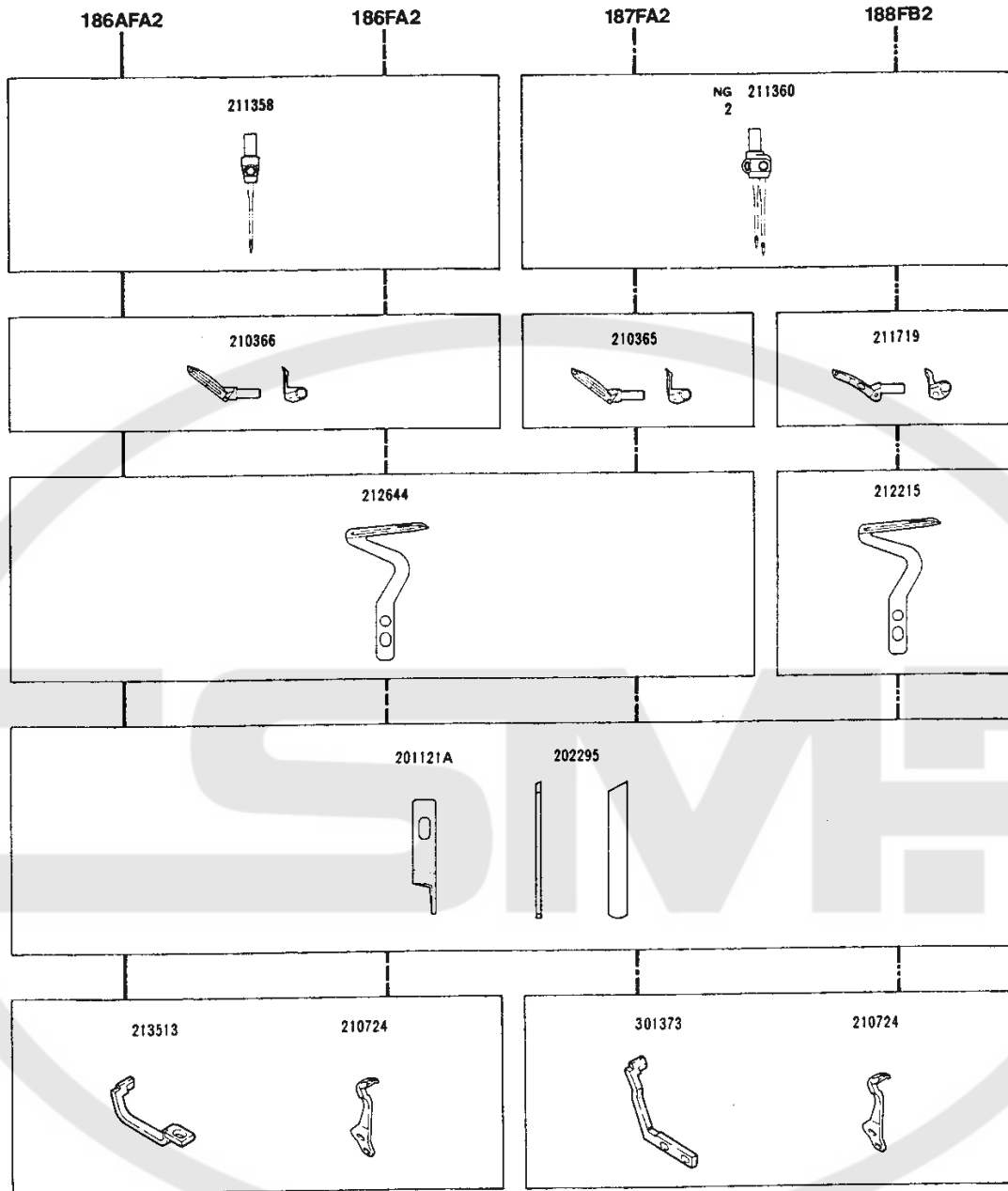

									MEMO	
9752-186FA2 /04-393-W			3, 4, 5	3.8	0.75~1.5	0.7~2	5,500	H		Used for BL
9752-186AFA2 /04-363-W			3, 4, 5	"	"	"	"	"		"
9752-187FA2 /14-393-W	2		3, 4, 5	"	"	"	"	"		"
9752-188FB2 /14-493-W	2		3, 4, 5	"	1.2~3.6	1.1~3.2	4,500	EX		"

9752-130FA2/04-363-N
 9752-133FA2/14-363-N
 9752-141FA2/04-463-W
 9752-142FA2/14-463-W

9752-130FA3/04-363-N
 9752-133FA3/14-363-N
 9752-141FA3/04-463-W
 9752-142FA3/14-463-W

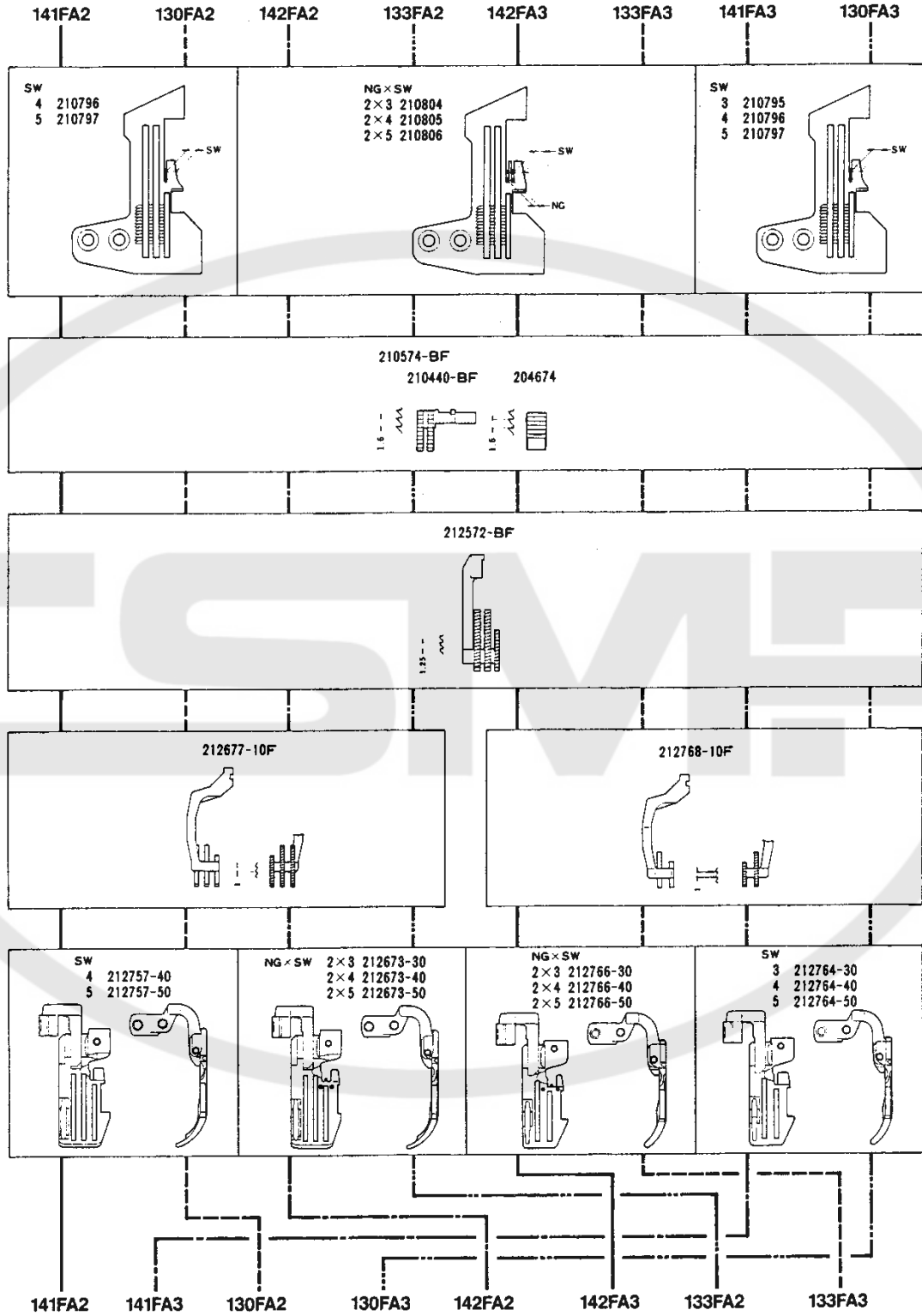

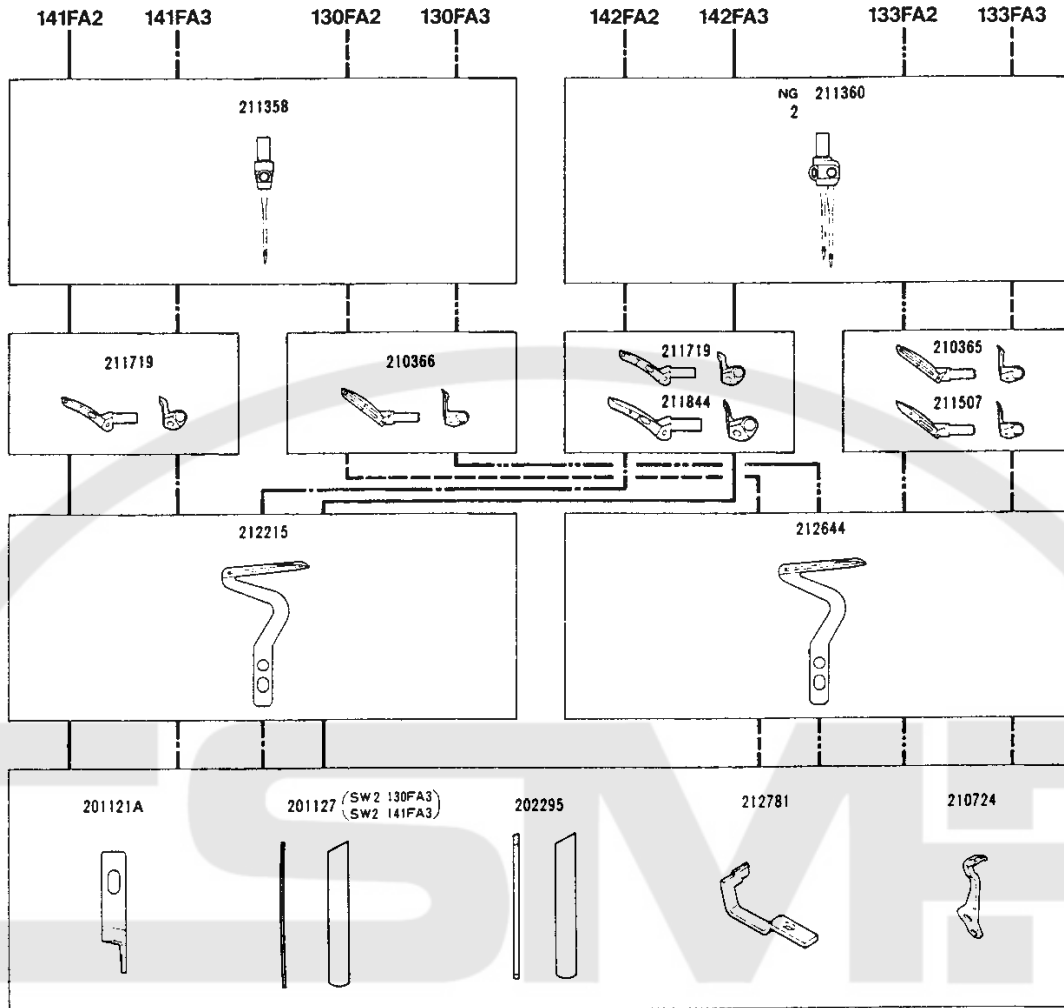

SEAMING

					CF	OF		MEMO	
9752-141FA2 /04-463-W			4.5	3.8	0.7~1.5	0.7~2	6,000	EX	Medium to heavy fabrics Sportswear
9752-130FA2 /04-363-N			4.5	"	"	"	"	HI	Light to medium fabrics. Sportswear
9752-142FA2 /14-463-W	2		3, 4, 5	"	"	"	"	EX	Medium to heavy fabrics. Sportswear, childrens' wear
9752-133FA2 /14-363-N	2		3, 4, 5	"	"	"	"	HI	Light to medium fabrics. Sports shirts

SEAMING

					CF	OF		MEMO	
9752-141FA3 /04-463-W			3, 4, 5	3.8	0.7~1.5	0.7~2	6,000	EX	Medium to heavy fabrics. Sportswear
9752-130FA3 /04-363-N			3, 4, 5	"	"	"	"	HI	Light to medium fabrics. Sports shirts
9752-142FA3 /14-463-W	2		3, 4, 5	"	"	"	"	EX	Medium to heavy fabrics. Sportswear, childrens' wear
9752-133FA3 /14-363-N	2		3, 4, 5	"	"	"	"	HI	Light to medium fabrics. Sports shirts

9752-243FD2/14-463-W/KL100
 9752-245FD2/14-363-W/KL100

9752-243FD3/14-463-W/KL100
 9752-245FD3/14-363-W/KL100
 9752-243FD4/P1(P2)/14-463-W/KL100

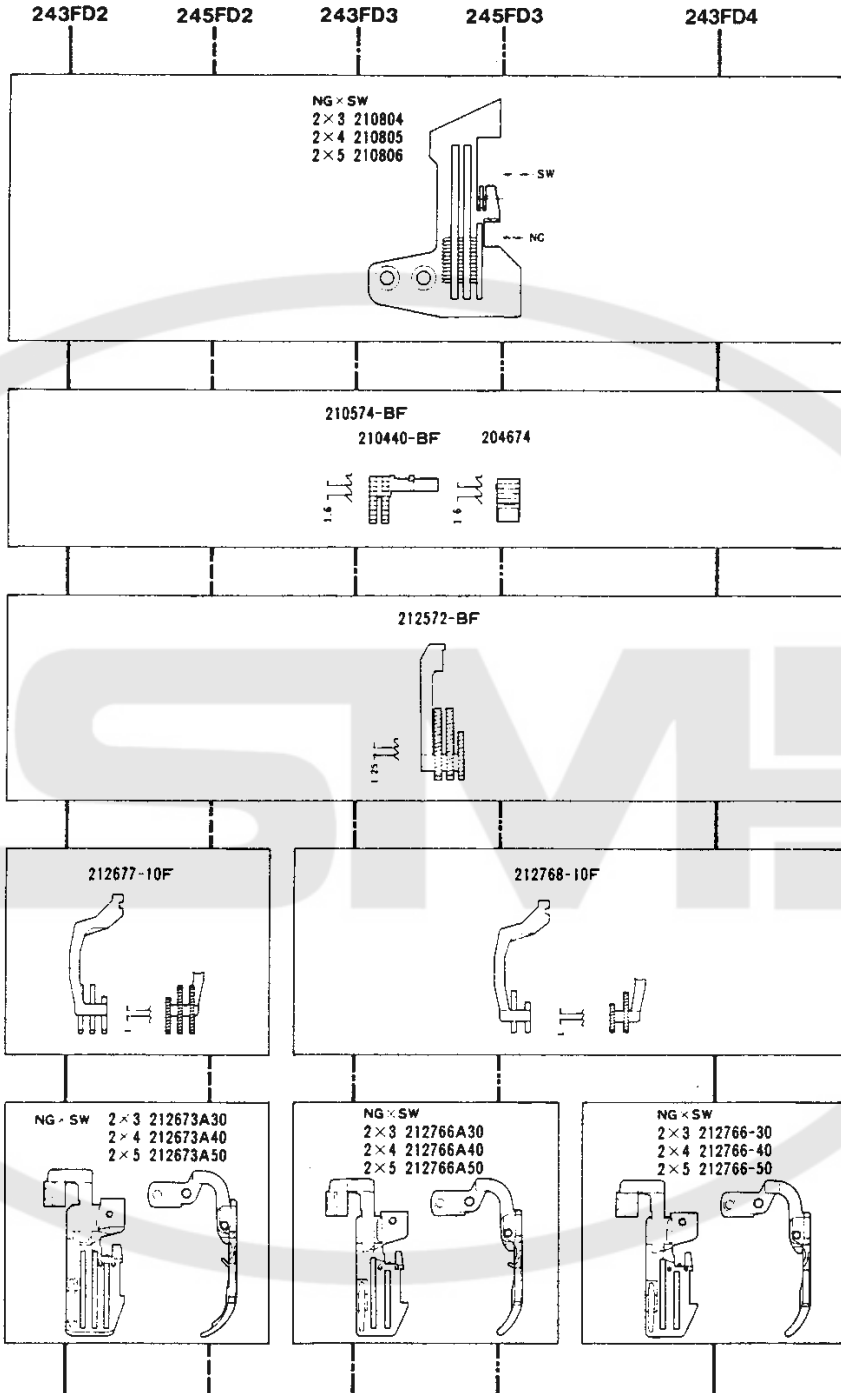

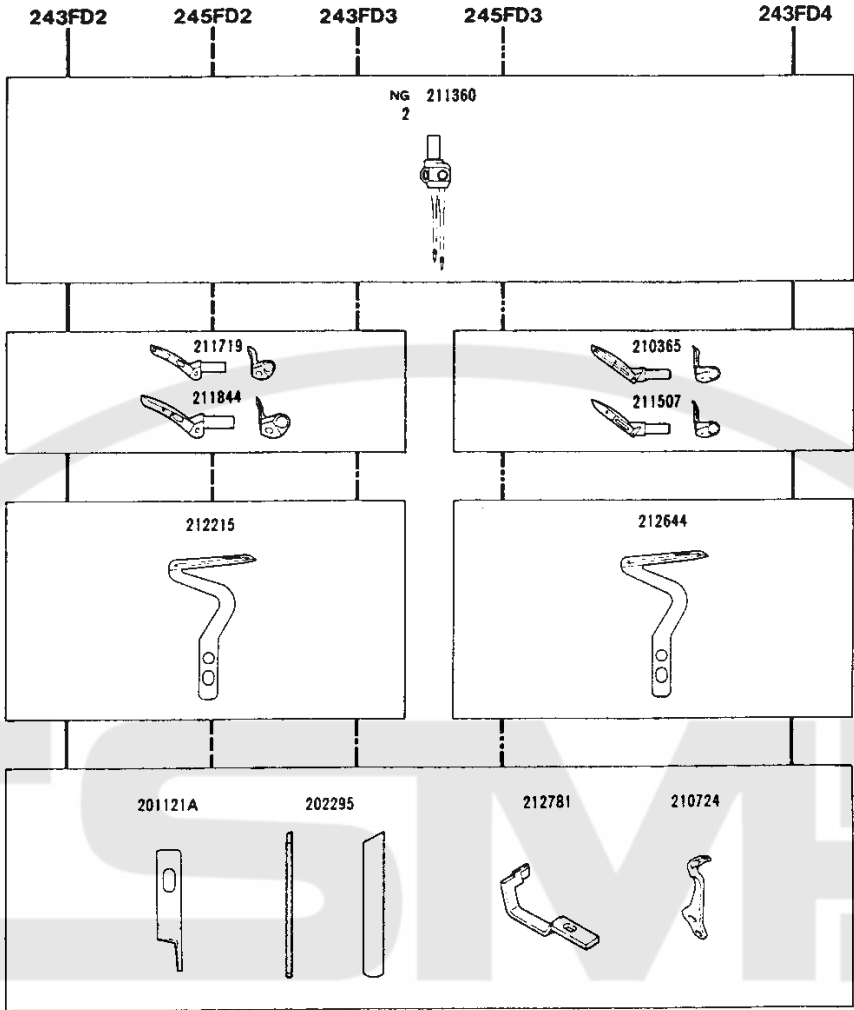

GATHERING

									MEMO	
9752-243FD2 /14-463-W/KL100	2	3, 4, 5	3.8	0.7~1.9	0.7~2	5,500	EX			Medium to heavy fabrics. Curtains, childrens' wear
9752-245FD2 /14-363-W/KL100	2	3, 4, 5	"	"	"	"	H1			Operations lighter than 243FD2. Curtains, childrens' wear
9752-243FD3 /14-463-W/KL100	2	3, 4, 5	3.8	0.7~1.9	0.7~2	5,000	EX			Medium to heavy fabrics. Curtains, childrens' wear
9752-245FD3 /14-363-W/KL100	2	3, 4, 5	"	"	"	"	H1			Operations lighter than 243FD2. Curtains, childrens' wear

GATHERING·PIPING

									MEMO	
9752-243FD4/P1(P2) /14-463-W/KL100	2	3, 4, 5	3.8	0.7~2	0.7~2	5,500	EX			Curtains, childrens' wear

9752-142FB2/S1/14-463-W
 9752-142FB2/S2/14-463-W/KL100

9752-253FB2/S1/14-493-W
 9752-253FB2/S2/14-493-W/KL100
 9752-253FB2K/S1/14-493-W
 9752-253FB2K/S2/14-493-W/KL100

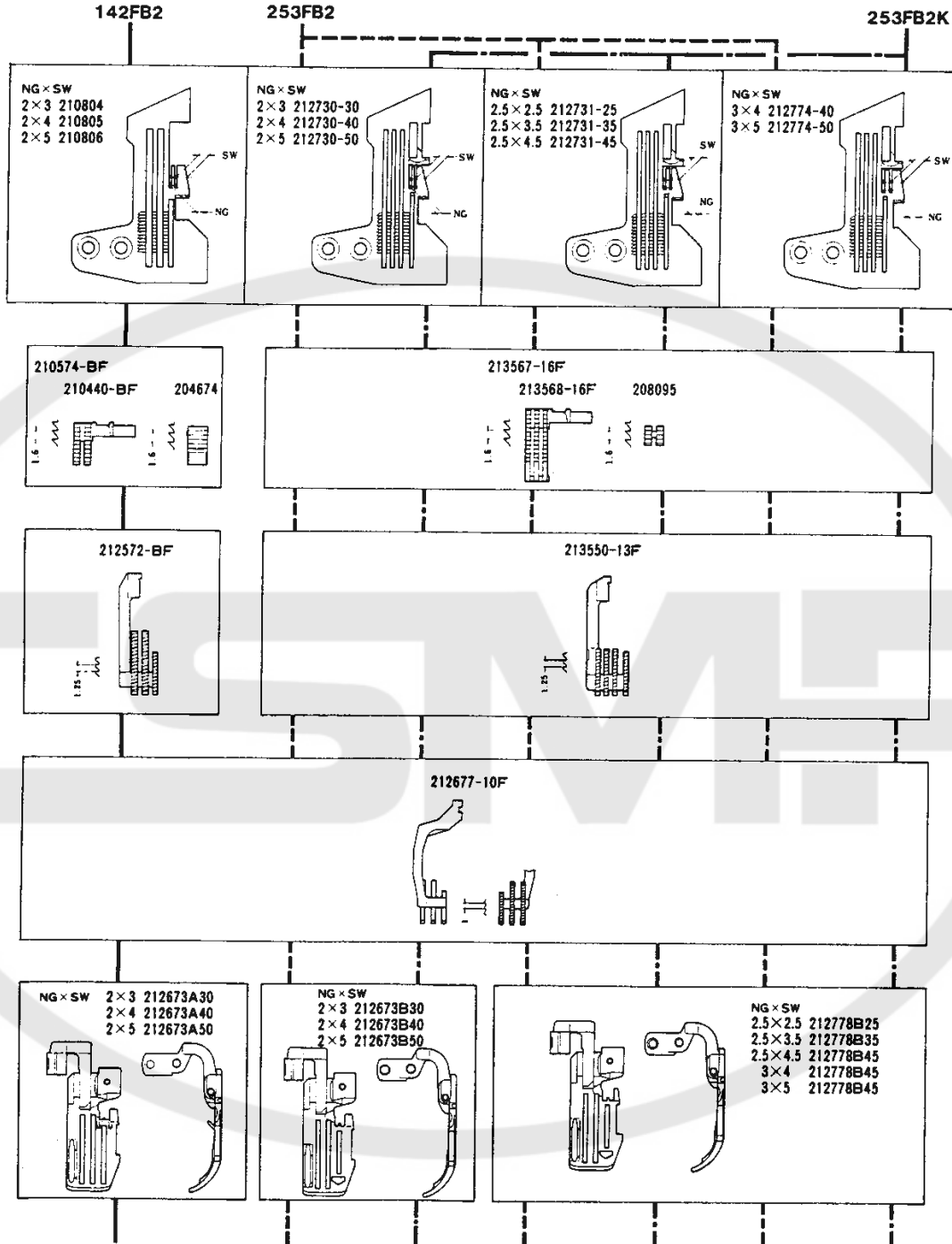

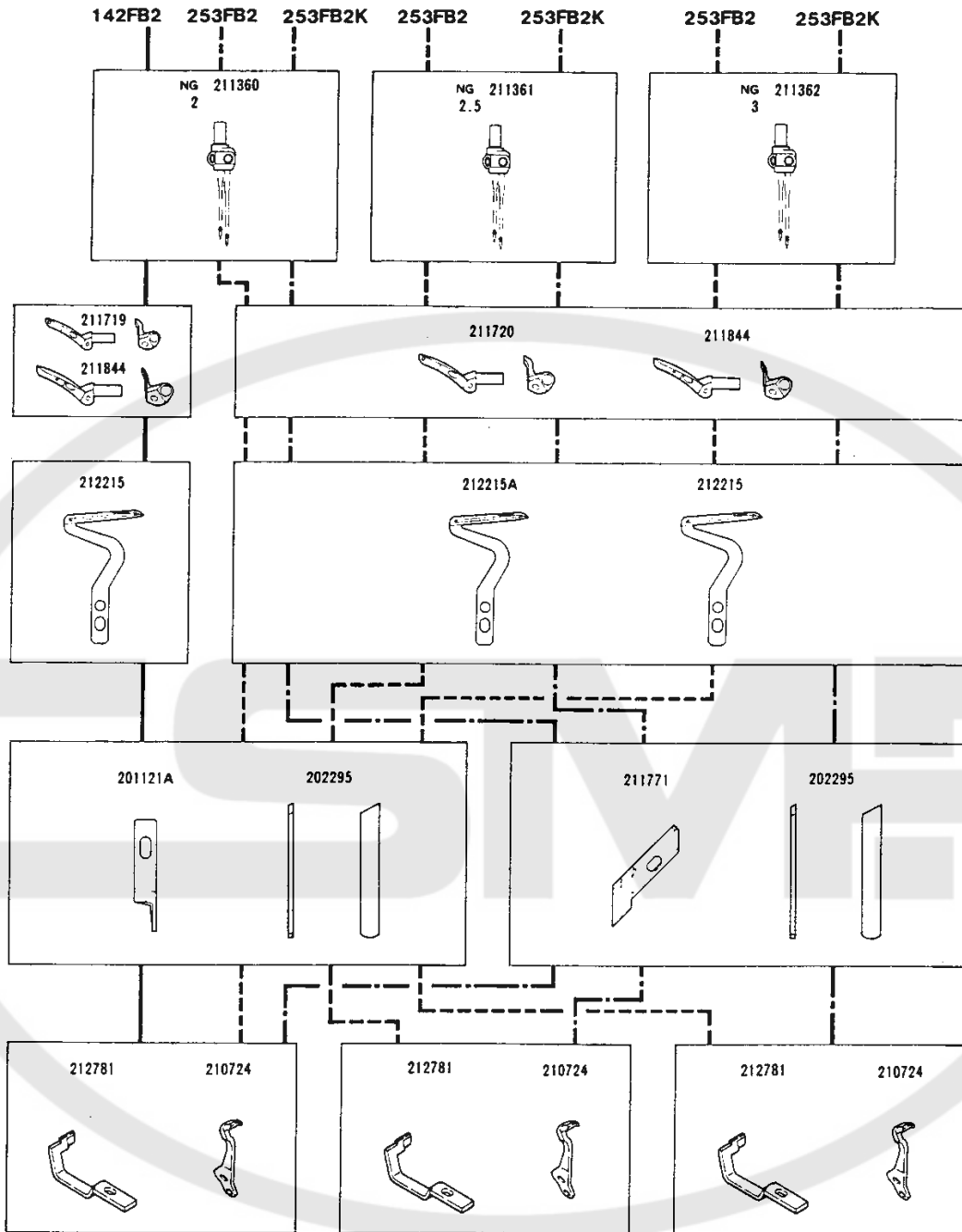

SEAMING · ATTACHING TAPE

										MEMO	
9752-142FB2/S1 /14-463-W	2	3, 4, 5	2.4	1.2~3.6	1.1~3.2	5,000	EX			Medium to heavy fabrics. Sweater, sports wear	
9752-142FB2/S1 (S2) /14-493-W	2 2.5 3	3, 4, 5 2.5, 3.5, 4.5 4, 5	3.2	0.8~2.6	0.8~2.8	5,000	"			Attaching tape. Medium to heavy. Sweaters, sportswear	
9752-253FB2/S1 (S2) /14-493-W	2 2.5 3	3, 4, 5 2.5, 3.5, 4.5 4, 5	"	"	"	"	"			Same applications as -253FB2 but with an angled upper knife.	

9752-350BC2/P1(P2)/04-453-W
 9752-351BC2/P1(P2)/14-453-W

9752-350FC2/P1(P2)/04-453-W
 9752-351FC2/P1(P2)/14-453-W
 9752-352FC2/P1(P2)/14-353-W

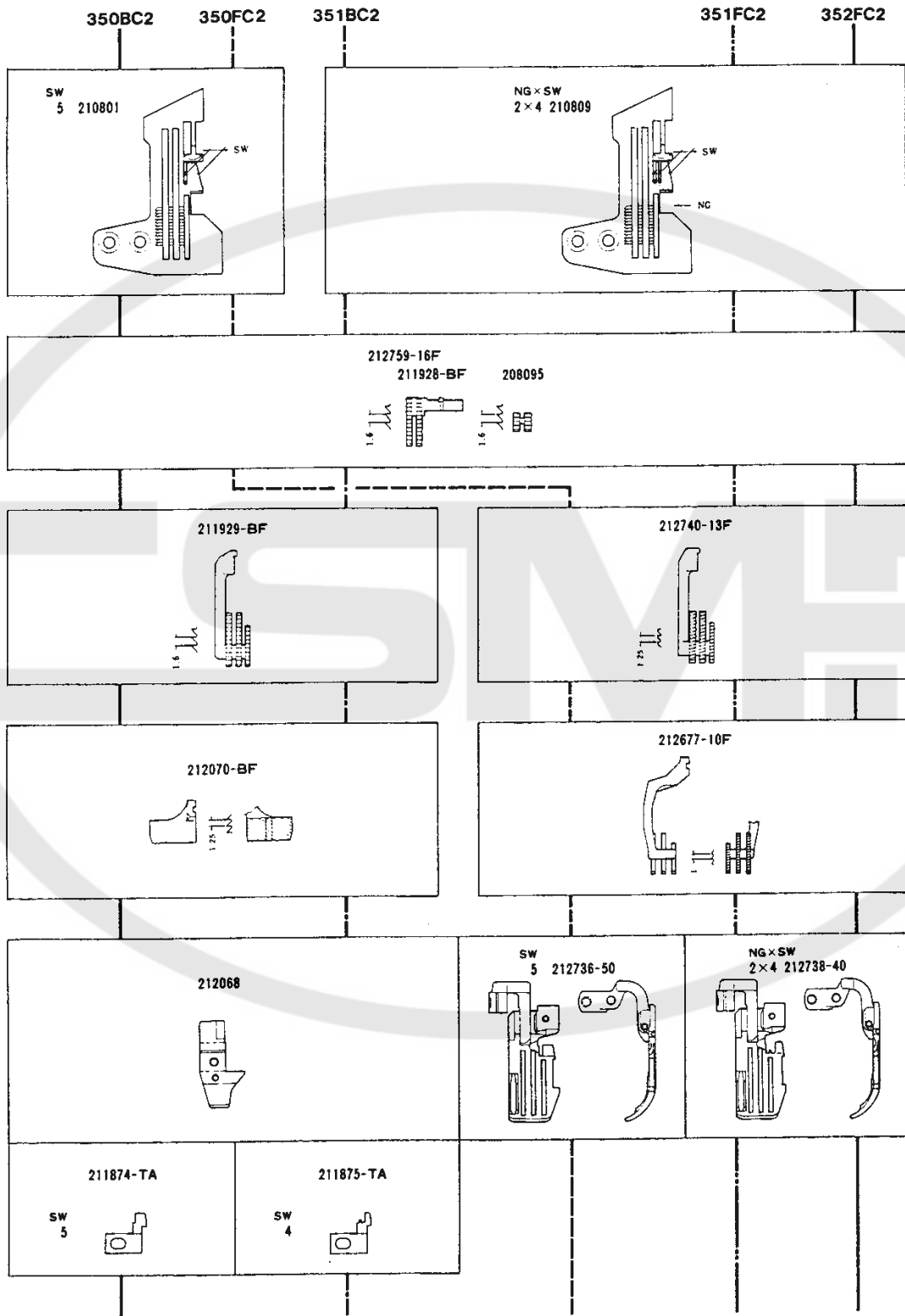

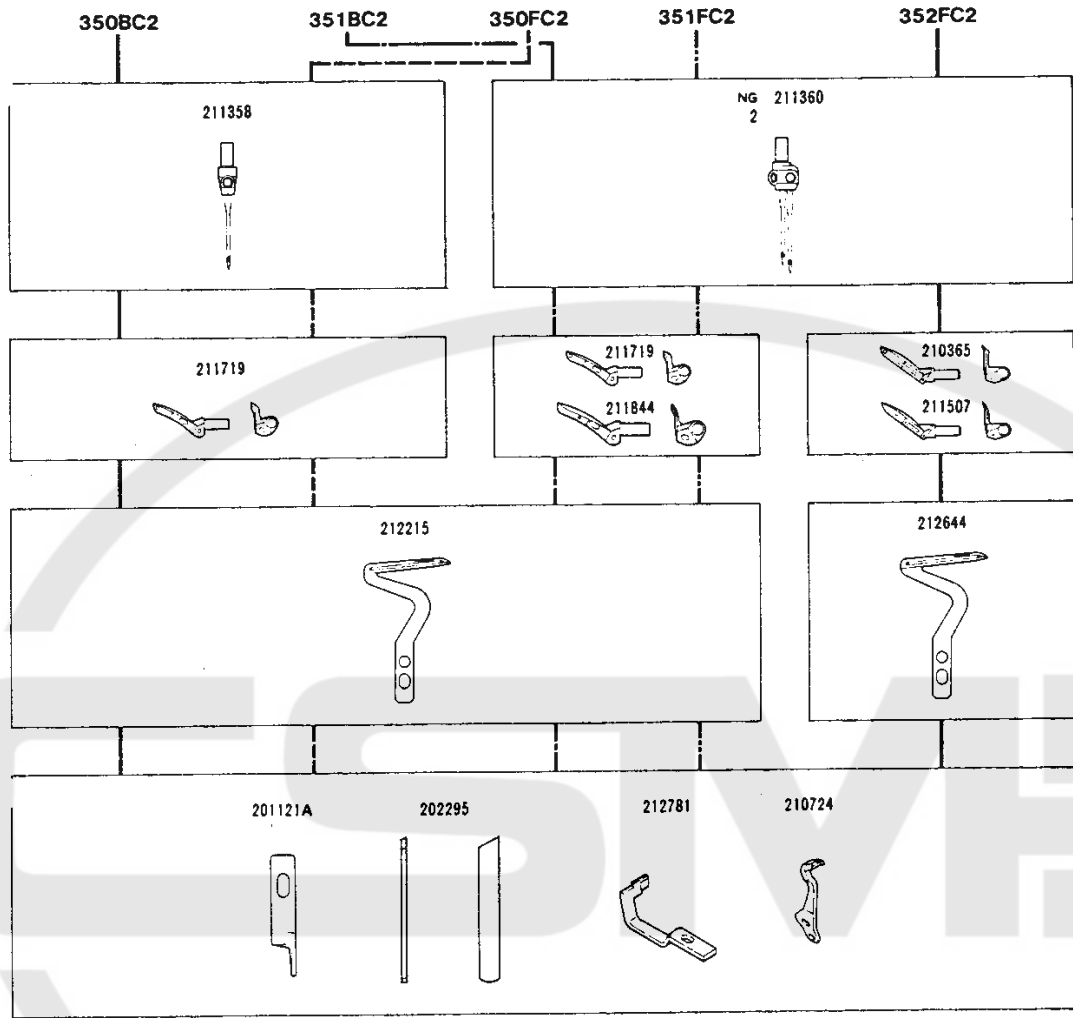

PIPING

				$\frac{OF}{NO}$	$\frac{W}{NO}$			MEMO	
9752-350BC2/P1(P2) /04-453-W		5	3.8	0.7~1.5	0.7~2	6,000	EX		Jeans
9752-351BC2/P1(P2) /14-453-W /12-453-W	2	4	"	"	"	"	EX		Sportswear Jeans

PIPING

				$\frac{OF}{NO}$	$\frac{W}{NO}$			MEMO	
9752-350FC2/P1(P2) -453-W		5	3.8	0.7~1.5	0.7~2	6,000	EX		Sportswear, casual wear
9752-351FC2/P1(P2) /14-453-W /12-453-W	2	4	"	"	"	"	"		Medium to heavy fabrics. Sportswear, casual wear
9752-352FC2/P1(P2) /14-353-W /12-353-W	2	4	"	"	"	"	H I		Operations lighter than -351FC2. Curtains, childrens' wear

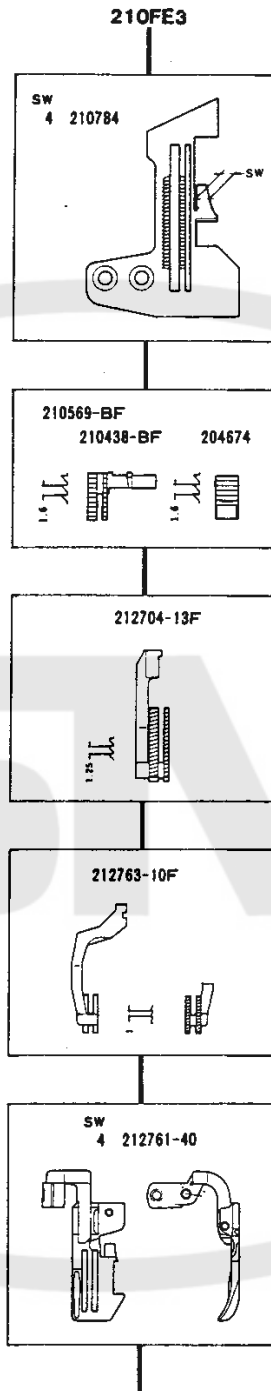

210FE3

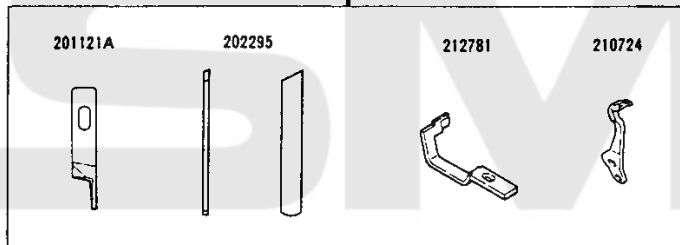
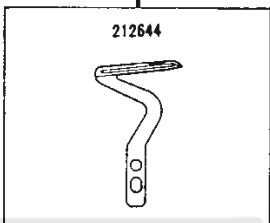
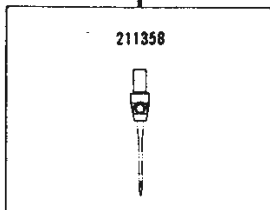

BLINDHEMMING

									MEMO	
9752-210FE3 /05-323-N		4	3.8	0.7~1.5	0.7~2	6,000	HI			Underwear, T-shirts

9752-141BA2/04-463-W
 9752-142BA2/14-463-W

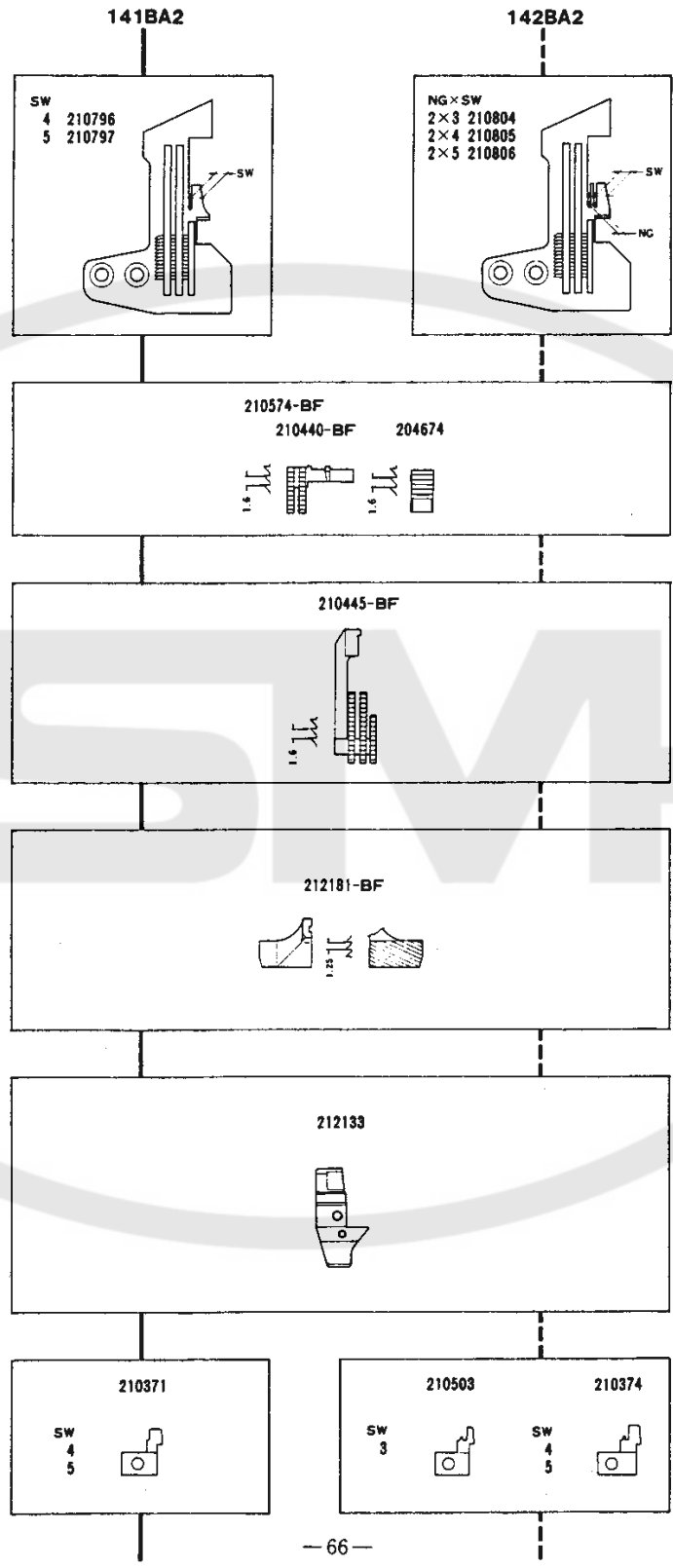

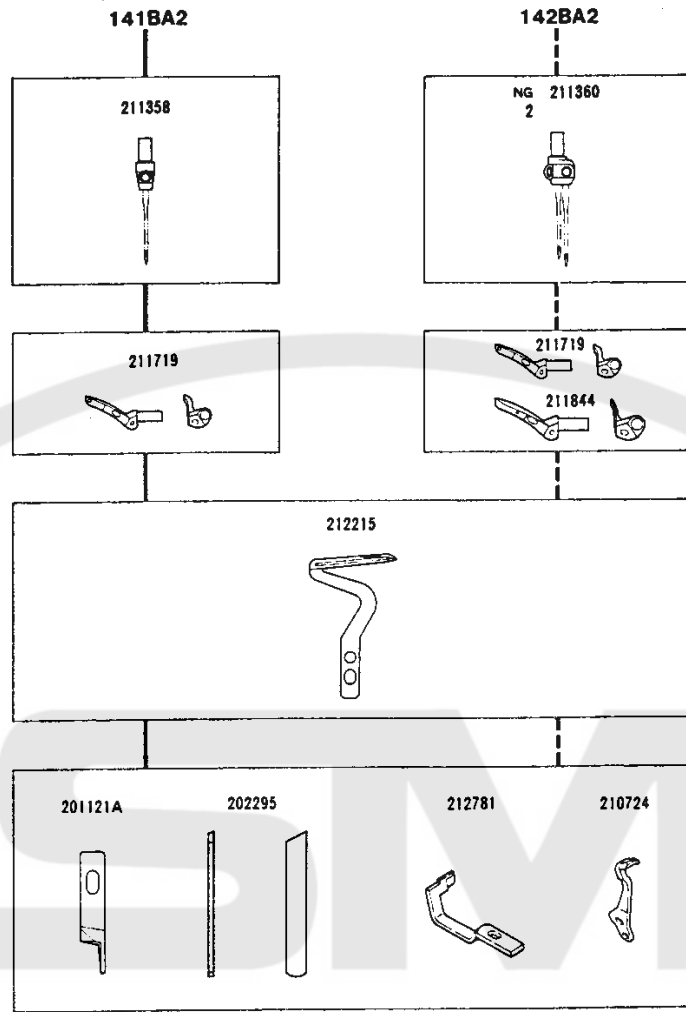

SEAMING·SERGING

									MEMO	
9752-141BA2 /04-463-W			4, 5	3, 8	0.7-1.5	0.7-2	6,000	EX		Jeans
9752-142BA2 /14-463-W /12		2	3, 4, 5	"	"	"	"	EX		Jeans

GAUGE PARTS LIST (1)
(USED FOR BL)

MACHINE TYPE SPEC.	GAUGE NG/SW	NEEDLE PLATE	MAIN FEED DOG COMP.	DIFF. FEED DOG	TOP FEED DOG	PRESSER BODY	FOOT FINGER	UPPER LOOPER	LOWER LOOPER	FOR S12 ONLY	
										UPPER LOOPER	LOWER LOOPER
9752-186FA2 /04-393-W	3	213514-30	213571-16F	213574-13F	213570-10F	213576-30	-----	210366	212644	-----	-----
	4	" -40	"	"	"	" -40	-----	" #26	"	-----	-----
	5	" -50	"	"	"	" -50	-----	"	"	-----	-----
9752-186FA2 /04-363-W	4	213548-40	213571-16F	213575-13F	213570-10F	213576-40	-----	210366	212644	-----	-----
	5	" -50	"	"	"	" -50	-----	" #26	"	-----	-----
9752-187FA2 /14-393-W	2	213542-30	213573-16F	213574-13F	212677-10F	212673-30	-----	210365	212644	-----	-----
	4	" -40	"	"	"	" -40	-----	" #24	"	-----	-----
9752-188FB2 /14-493-W	2	213542-30	213572-16F	212760-13F	212677-10F	212673-30	-----	211719	212215	-----	-----
	4	" -40	"	"	"	" -40	-----	" #38	"	-----	-----

MACHINE TYPE SPEC.	GAUGE NG/SW	NEEDLE HOLDER	UPPER KNIFE	LOWER KNIFE	NEEDLE (FRONT)	GUARD (REAR)	NEEDLE
	4	"	"	"	"	"	
	5	"	"	"	"	"	
9752-186FA2 /04-363-W	4	211358	201121A	202295	213513	210724	DCX27 #9
	5	"	"	"	"	"	
9752-187FA2 /14-393-W	2	211360	201121A	202295	301373	210724	DCX27 #9
	4	"	"	"	"	"	
9752-188FB2 /14-493-W	2	211360	201121A	202295	301373	210724	DCX27 #9
	4	"	"	"	"	"	

GAUGE PARTS LIST (3)

MACHINE TYPE SPEC.	GAUGE NG SW	NEEDLE PLATE	MAIN FEED DOG COMP.	DIFF. FEED DOG	TOP FEED DOG	PRESSER		FOOT FINGER	UPPER LOOPER	LOWER LOOPER	FOR 512 ONLY	
						BODY	DOG				UPPER LOOPER	LOWER LOOPER
9752-142F82/S1(S2) /14-463-W/KL100 /12-463-W/KL100	2	210804	210574-BF	212572-BF	212677-10F	212673A30	211719	212215	211844	212215	211844	212215
	2	210805	"	"	"	" A40	" #38	"	" #42	"	" #42	"
	2	210806	"	"	"	" A50	"	"	"	"	"	"
9752-243FD2 /14-463-W/KL100 /12-463-W/KL100	2	210804	210574-BF	212572-BF	212677-10F	212673A30	211719	212215	211844	212215	211844	212215
	2	210805	"	"	"	" A40	" #38	"	" #42	"	" #42	"
	2	210806	"	"	"	" A50	"	"	"	"	"	"
9752-245FD2 /14-363-W/KL100 /12-363-W/KL100	2	210804	210574-BF	212572-BF	212677-10F	212673A30	210365	212644	211507	212644	211507	212644
	2	210805	"	"	"	" A40	" #24	"	"	"	"	"
	2	210806	"	"	"	" A50	"	"	"	"	"	"

MACHINE TYPE SPEC.	GAUGE NG SW	NEEDLE HOLDER	UPPER KNIFE	LOWER KNIFE	NEEDLE (FRONT)	GUARD (REAR)	NEEDLE
9752-243FD2 /14-463-W/KL100 /12-463-W/KL100	2	211360	201121A	202295	212781	210724	DCX27 #11
	2	"	"	"	"	"	"
	2	"	"	"	"	"	"
9752-245FD2 /14-363-W/KL100 /12-363-W/KL100	2	211360	201121A	202295	212781	210724	DCX27 #11
	2	"	"	"	"	"	"
	2	"	"	"	"	"	"

GAUGE PARTS LIST (4)

MACHINE TYPE SPEC.	GAUGE NG / SW	NEEDLE PLATE	MAIN FEED DOG COMP.	DIFF. FEED DOG	TOP FEED DOG	PRESSER BODY	FOOT FINGER	UPPER LOOPER	LOWER LOOPER	FOR S12 ONLY		
										UPPER LOOPER	LOWER LOOPER	
9752-253FB2/S1(S2) /14-493-W/KL100 /12-493-W/KL100	2 3	212730-30	213567-16F	213550-13F	212677A10F	212673B30	-----	211720	212215A	211844	212215	
	2 4	" -40	" "	" "	" "	B40	-----	" #40	" "	" #42	" "	
	2 5	" -50	" "	" "	" "	B50	-----	" "	" "	" "	" "	
	2 52-5	212731-25	" "	" "	" "	212778B25	-----	" "	" "	" "	" "	
	2 53-5	" -35	" "	" "	" "	B35	-----	" "	" "	" "	" "	
	2 54-5	" -45	" "	" "	" "	B45	-----	" "	" "	" "	" "	
	3 4	212774-40	" "	" "	" "	212778B45	-----	" "	" "	" "	" "	
	3 5	" -50	" "	" "	" "	" "	-----	" "	" "	" "	" "	
	9752-253FB2K/S1(S2) /14-493-W/KL100 /12-493-W/KL100	2 3	212730-30	213567-16F	213550-13F	212677A10F	212673B30	-----	211720	212215A	211844	212215
		2 4	" -40	" "	" "	" "	B40	-----	" #40	" "	" #42	" "
		2 5	" -50	" "	" "	" "	B50	-----	" "	" "	" "	" "
		2 52-5	212731-25	" "	" "	" "	212778B25	-----	" "	" "	" "	" "
		2 53-5	" -35	" "	" "	" "	B35	-----	" "	" "	" "	" "
		2 54-5	" -45	" "	" "	" "	B45	-----	" "	" "	" "	" "
		3 4	212774-40	" "	" "	" "	212778B45	-----	" "	" "	" "	" "
3 5		" -50	" "	" "	" "	" "	-----	" "	" "	" "	" "	

MACHINE TYPE SPEC.	GAUGE NG / SW	NEEDLE HOLDER	UPPER KNIFE	LOWER KNIFE	NEEDLE (FRONT)	GUARD (REAR)	NEEDLE
	2 4	" "	" "	" "	" "	" "	" "
	2 5	" "	" "	" "	" "	" "	" "
	2 52-5	211361	" "	" "	" "	" "	" "
	2 53-5	" "	" "	" "	" "	" "	" "
	2 54-5	" "	" "	" "	" "	" "	" "
	3 4	211362	" "	" "	" "	" "	" "
	3 5	" "	" "	" "	" "	" "	" "
9752-253FB2K/S1(S2) /14-493-W/KL100 /12-493-W/KL100	2 3	211360	211771	202295	212781	210724	DCX27 #11
	2 4	" "	" "	" "	" "	" "	" "
	2 5	" "	" "	" "	" "	" "	" "
	2 52-5	211361	" "	" "	" "	" "	" "
	2 53-5	" "	" "	" "	" "	" "	" "
	2 54-5	" "	" "	" "	" "	" "	" "
	3 4	211362	" "	" "	" "	" "	" "
	3 5	" "	" "	" "	" "	" "	" "

GAUGE PARTS LIST (5)

MACHINE TYPE SPEC.	GAUGE NG SW	NEEDLE PLATE	MAIN FEED DOG COMP.	DIFF. FEED DOG	TOP FEED DOG	PRESSER BODY	FOOT FINGER	UPPER LOOPER	LOWER LOOPER	FOR 512 ONLY	
										UPPER LOOPER	LOWER LOOPER
9752-350FC2/P1(P2) /04-453-W	5	210801	212759-16F	212740-13F	212677-10F	212736-50	-----	211719 #38	212215	-----	-----
9752-351FC2/P1(P2) /14-453-W /12-453-W	2 4	210809	212759-16F	212740-13F	212677-10F	212738-40	-----	211719 #38	212215	211844 #42	212215
9752-352FC2/P1(P2) /14-353-W /12-353-W	2 4	210809	212759-16F	212740-13F	212677-10F	212738-40	-----	210365 #24	212644	211507 #36	212644

MACHINE TYPE SPEC.	GAUGE NG SW	NEEDLE HOLDER	UPPER KNIFE	LOWER KNIFE	NEEDLE (FRONT)	GUARD (REAR)	NEEDLE
9752-351FC2/P1(P2) /14-453-W /12-453-W	2 4	211360	201121A	202295	212781	210724	DCX27 #11
9752-352FC2/P1(P2) /14-353-W /12-353-W	2 4	211360	201121A	202295	212781	210724	DCX27 #11

GAUGE PARTS LIST (6)

MACHINE TYPE SPEC.	GAUGE NG/SW	NEEDLE PLATE	MAIN FEED DOG COMP.	DIFF. FEED DOG	TOP FEED DOG	PRESSER BODY	FOOT FINGER		UPPER LOOPER	LOWER LOOPER	FOR 512 ONLY	
							UPPER	LOWER			UPPER LOOPER	LOWER LOOPER
9752-130FA3 /04-363-N	3	210795	210574-3F	212572-8F	212768-10F	212766-30	-----	210366	212644	-----	-----	
	4	210796	"	"	"	-40	-----	" #26	"	-----	-----	
	5	210797	"	"	"	-50	-----	"	"	-----	-----	
9752-133FA3 /14-363-N /12-363-N	2	210804	210574-8F	212572-8F	212768-10F	212766-30	-----	210365	212644	-----	212644	
	4	210805	"	"	"	-40	-----	" #24	"	-----	" #36	
	5	210806	"	"	"	-50	-----	"	"	-----	"	
9752-141FA3 /04-463-W	3	210795	210574-8F	212572-8F	212768-10F	212766-30	-----	211719	212215	-----	-----	
	4	210796	"	"	"	-40	-----	" #38	"	-----	-----	
	5	210797	"	"	"	-50	-----	"	"	-----	-----	
9752-142FA3 /14-463-W /12-463-W	2	3	210804	210574-3F	212572-8F	212766-30	-----	211719	212215	-----	212215	
	2	4	210805	"	"	-40	-----	" #38	"	-----	" #42	
	2	5	210806	"	"	-50	-----	"	"	-----	"	

MACHINE TYPE SPEC.	GAUGE NG/SW	NEEDLE HOLDER	UPPER KNIFE	LOWER KNIFE	NEEDLE (FRONT)	GUARD (REAR)	NEEDLE
9752-133FA3 /14-363-N /12-363-N	2	3	201121A	202295	212781	210724	DCX27 #11
	2	4	"	"	"	"	"
	2	5	"	"	"	"	"
9752-141FA3 /04-463-W	3	211358	201121A	201127 202295	212781	210724	DCX27 #11
	4	"	"	"	"	"	"
	5	"	"	"	"	"	"
9752-142FA3 /14-463-W /12-463-W	2	3	201121A	202295	212781	210724	DCX27 #11
	2	4	"	"	"	"	"
	2	5	"	"	"	"	"

GAUGE PARTS LIST (7)

MACHINE TYPE SPEC.	GAUGE NG/SM	NEEDLE PLATE	MAIN FEED DOG COMP.	DIFF. FEED DOG	TOP FEED DOG	PRESSER BODY	FOOT FINGER	UPPER LOOPER	LOWER LOOPER	FOR S12 ONLY	
										UPPER LOOPER	LOWER LOOPER
9752-210FE3 /05-323-N	4	210784	210569-BF	212704-13F	212763-10F	212761-40	-----	210366 #26	212644	-----	-----
9752-243FD3 /14-463-W/KL100 /12-463-W/KL100	2 3 2 2 5	210804 210605 210806	210574-BF	212572-BF	212768-10F	212766A30 " A40 A50	-----	211719 " #38	212215	211844 " #42	212215
9752-243FD4/P1(P2) /14-463-W/KL100 /12-463-W/KL100	2 3 2 2 5	210804 210805 210806	210574-BF	212572-BF	212768-10F	212766-30 " -40 -50	-----	211719 " #38	212215	211844 " #42	212215
9752-245FD3 /14-363-W/KL100 /12-363-W/KL100	2 3 2 2 5	210804 210805 210806	210574-BF	212572-6F	212768-10F	212766A30 " A40 A50	-----	210365 " #24	212644	211507 " #36	212644

MACHINE TYPE SPEC.	GAUGE NG/SM	NEEDLE HOLDER	UPPER KNIFE	LOWER KNIFE	NEEDLE (FRONT)	GUARD (REAR)	NEEDLE
9752-243FD3 /14-463-W/KL100 /12-463-W/KL100	2 3 2 2 5	211360 " " " " " "	201121A " " " " " "	202295 " " " " " "	212781 " " " " " "	210724 " " " " " "	DCX27 #11
9752-243FD4/P1(P2) /14-463-W/KL100 /12-463-W/KL100	2 3 2 2 5	211360 " " " " " "	201121A " " " " " "	202295 " " " " " "	212781 " " " " " "	210724 " " " " " "	DCX27 #11
9752-245FD3 /14-363-W/KL100 /12-363-W/KL100	2 3 2 2 5	211360 " " " " " "	201121A " " " " " "	202295 " " " " " "	212781 " " " " " "	210724 " " " " " "	DCX27 #11

GAUGE PARTS LIST (8)

MACHINE TYPE SPEC.	GAUGE NG/ SW	NEEDLE PLATE	MAIN FEED DOG COMP.	DIFF. DOG FEED DOG	TOP FEED DOG	PRESSER BODY	FOOT FINGER	FOR S12 ONLY				
								UPPER LOOPER	LOWER LOOPER	UPPER LOOPER	LOWER LOOPER	
9752-1418A2 /04-463-W	4	210796	210574-BF	210445-BF	212181-BF	212133	210371	211719 #38	212215	212215	211844 #42	212215
	5	210797	"	"	"	"	"	"	"	"	"	"
9752-1428A2 /14-463-W	2	210804	210574-BF	210445-BF	212181-BF	212133	210503	211719 #38	212215	212215	211844 #42	212215
	4	210805	"	"	"	"	210374	"	"	"	"	"
9752-3508C2/P1(P2) /04-453-W	2	210806	"	"	"	"	"	211719 #38	212215	212215	211844 #42	212215
	5	210801	212759-16F	211929-BF	212070-BF	212068	211874-TA	211719 #38	212215	212215	211844 #42	212215
9752-3518C2/P1(P2) /14-453-W	2	210809	212759-16F	211929-BF	212070-BF	212068	211875-TA	211719 #38	212215	212215	211844 #42	212215
	4	210809	"	"	"	"	"	"	"	"	"	"

MACHINE TYPE SPEC.	GAUGE NG/ SW	NEEDLE HOLDER	UPPER KNIFE	LOWER KNIFE	NEEDLE (FRONT)	GUARD (REAR)	NEEDLE
9752-1428A2 /14-463-W	5	"	"	"	"	"	"
	2	211360	201121A	202295	212781	210724	DCX27 #11
9752-3508C2/P1(P2) /04-453-W	2	"	"	"	"	"	"
	4	211358	201121A	202295	212781	210724	DCX27 #11
9752-3518C2/P1(P2) /14-453-W	2	211360	201121A	202295	212781	210724	DCX27 #11
	4	"	"	"	"	"	"

INDEX

PART NO.	PFAFF-NO	PAGE	NO. REF.	PART NO.	PFAFF-NO	PAGE	NO. REF.	PART NO.	PFAFF-NO	PAGE	NO. REF.
DCX27		68		1175-2	09-009 048-13	37	13	4803	09-009 612-30	53	25
DCX27		69		1175-2	09-009 048-13	43	26	4803	09-009 612-30	53	29
DCX27		70		1175-3	09-009 048-14	9	29	4803	09-009 612-30	53	8
DCX27		71		1196	09-009 048-16	43	36	4803	09-009 612-30	53	22
DCX27		72		1202	09-009 048-17	9	39	4803	09-009 612-30	53	29
DCX27		73		1202	09-009 048-17	47	19	4803	09-009 612-30	53	22
DCX27		74		1202	09-009 048-17	47	26	4805	09-400 065-00	45	24
DCX27		75		1216	09-009 048-20	9	24	4805	09-400 065-00	53	18
127	91-029 007-91	51	11	1216	09-009 048-20	9	44	4805	09-400 065-00	53	34
128	91-029 480-91	51	12	1227	09-009 804-05	33	33	4805	09-400 065-00	53	18
131	09-009 815-08	51	16	1231	09-009 048-09	19	27	4805	09-400 065-00	53	34
153	09-009 819-55	51	15	1231	09-009 048-09	23	25	4806	09-009 807-13	43	9
178	09-009 600-03	51	5	1234	09-009 048-23	43	32	4818	09-009 732-56	47	37
179	09-009 071-00	51	14	1333	09-009 048-27	35	57	4904	09-009 612-31	49	12
200	09-009 815-07	51	10	1435	09-009 048-63	7	25	4906	09-009 807-14	45	12
233-CA	09-009 619-24	53	23	1448	09-009 054-64	13	9	4906	09-009 807-14	45	15
233-CA	09-009 619-24	53	23	1457	09-009 048-64	15	7	4906	09-009 807-14	49	16
272	09-009 612-01	49	31	1458	09-009 048-66	39	8	4908	09-009 732-57	47	39
282	09-009 048-05	51	6	1458	09-009 048-66	39	25	5012	09-009 065-32	7	6
284	09-009 048-25	51	7	1459	09-009 053-73	7	26	5012	09-009 065-32	9	48
285	09-009 048-26	51	8	1459	09-009 053-73	11	3	5012	09-009 065-32	19	43
293B	09-400 769-00	53	27	1459	09-009 053-73	11	18	5012	09-009 065-32	41	7
293B	09-400 769-00	53	27	1459	09-009 053-73	35	33	5022	09-009 068-68	15	12
293C	09-400 770-00	53	26	1459	09-009 053-73	43	12	5022	09-009 068-68	17	29
293C	09-400 770-00	53	26	1732	09-009 048-67	25	44	5029	09-009 053-59	13	8
322	09-009 815-06	51	9	1998-2	09-009 048-69	21	6	5029	09-009 053-59	35	44
380A	09-009 807-04	53	6	1998-2	09-009 048-69	21	17	5030	09-009 053-60	35	29
380A	09-009 807-04	53	6	1998-2	09-009 048-69	31	25	5030	09-009 053-60	35	59
381-CA	09-009 612-14	53	9	2133-1	09-009 053-36	3	6	5050	09-009 732-58	13	24
381-CA	09-009 612-14	53	9	2133-1	09-009 053-36	3	8	5053	09-009 053-62	31	12
382-CA	09-009 815-13	53	11	2133-1	09-009 053-36	27	13	5053	09-009 053-62	47	8
382-CA	09-009 815-13	53	11	2133-1	09-009 053-36	29	20	5059	09-009 612-34	15	26
383-CA	09-009 815-16	53	19	2193	09-009 053-37	19	18	5060	09-009 053-64	9	22
383-CA	09-009 815-16	53	19	2193	09-009 053-37	23	18	5060	09-009 053-64	15	33
384	09-009 612-17	53	20	2193	09-009 053-37	25	5	5060	09-009 053-64	37	4
384	09-009 612-17	53	20	2193	09-009 053-37	35	27	5060	09-009 053-64	39	4
386	09-009 612-19	53	36	2285B	09-009 823-61	35	2	5077	09-009 054-69	43	39
386	09-009 612-19	53	36	2902	09-009 053-42	19	30	5077	09-009 054-69	43	41
403	09-009 732-44	47	29	2902	09-009 053-42	27	44	5078	09-009 053-69	5	3
404	09-009 732-45	47	31	2902	09-009 053-42	33	4	5082A	09-009 053-74	17	8
405	09-009 732-46	47	35	2905	09-009 823-33	7	30	5082A	09-009 053-74	19	8
406	09-009 732-47	47	30	2905	09-009 823-33	9	15	5082A	09-009 053-74	23	8
407	09-009 732-48	47	33	2905	09-009 823-33	9	17	5084	09-009 053-76	25	32
408	09-009 732-49	47	34	2905	09-009 823-33	9	46	5084	09-009 053-76	27	15
409	09-009 732-50	47	34	2905	09-009 823-33	19	12	5084	09-009 053-76	33	18
410-JA	09-009 813-01	47	38	2905	09-009 823-33	25	46	5088	09-009 053-80	33	6
413	09-009 732-52	47	28	2905	09-009 823-33	29	37	5088	09-009 053-80	47	16
414	09-009 732-53	51	13	2905	09-009 823-33	31	4	5089	09-009 053-81	29	32
453	09-009 734-78	51	2	2905	09-009 823-33	37	40	5089	09-009 053-81	35	23
470	09-009 807-07	49	28	2905	09-009 823-33	39	53	5089	09-009 053-81	35	55
471	09-009 807-08	49	29	2905	09-009 823-33	43	4	5091	09-009 067-20	25	53
480	09-009 815-09	51	17	2906	09-009 612-23	47	11	5091	09-009 067-20	41	3
482	09-400 028-00	51	21	2913-1	09-009 054-67	5	27	5094	09-009 053-82	33	24
484	09-400 029-00	51	4	2921	09-009 053-46	35	25	5095	09-009 053-83	9	3
485	09-400 030-00	51	3	2921	09-009 053-46	35	51	5095	09-009 053-83	37	14
484B9C	09-400 773-00	53		2921	09-009 053-46	43	44	5095	09-009 053-83	39	11
486B9C	09-400 773-00	53		2921	09-009 053-46	43	48	5095	09-009 053-83	39	23
486C9C	09-400 774-00	53		3044	09-009 053-49	7	16	5104	09-009 600-23	43	24
486C9C	09-400 774-00	53		3044	09-009 053-49	31	9	5104	09-009 600-23	49	21
502-CA	09-009 815-14	53	15	3044	09-009 053-49	35	9	5111	09-009 807-16	43	6
502-CA	09-009 815-14	53	15	3044	09-009 053-49	45	8	5113	09-009 054-70	37	48
503-CA	09-009 815-12	53	1	3044	09-009 053-49	47	6	5113	09-009 054-70	39	62
503-CA	09-009 815-12	53	1	3091	09-009 053-50	7	20	5117	09-009 053-88	5	24
504-CA	09-400 779-00	53	16	3091	09-009 053-50	43	20	5117	09-009 053-88	9	9
504-CA	09-400 779-00	53	16	4009-1	09-009 053-53	5	17	5117	09-009 053-88	13	19
505-CA	09-400 781-00	53	4	4009-1	09-009 053-53	7	10	5117	09-009 053-88	17	13
505-CA	09-400 781-00	53	4	4009-1	09-009 053-53	7	34	5117	09-009 053-88	25	36
505ACA	09-400 780-00	53	5	4009-1	09-009 053-53	9	42	5117	09-009 053-88	25	42
505ACA	09-400 780-00	53	5	4009-1	09-009 053-53	19	48	5117	09-009 053-88	29	4
506	09-400 782-00	53	32	4009-1	09-009 053-53	27	11	5117	09-009 053-88	31	2
506	09-400 782-00	53	32	4009-1	09-009 053-53	33	22	5117	09-009 053-88	33	30
507	09-400 783-00	53	10	4009-1	09-009 053-53	45	6	5117	09-009 053-88	35	37
507	09-400 783-00	53	10	4012	09-009 612-25	47	32	5117	09-009 053-88	37	46
509	09-400 784-00	53	2	4012	09-009 612-25	53	24	5117	09-009 053-88	39	10
509	09-400 784-00	53	2	4012	09-009 612-25	53	28	5117	09-009 053-88	39	60
512	09-400 785-00	53	13	4012	09-009 612-25	53	24	5118	09-009 053-89	25	49
512	09-400 785-00	53	13	4012	09-009 612-25	53	28	5118	09-009 053-89	37	21
527-CA		53	30	4014	09-009 612-27	53	21	5118	09-009 053-89	39	17
527-CA		53	30	4014	09-009 612-27	53	21	5118	09-009 053-89	43	15
527ACA		53	31	4021	09-400 786-00	53	17	5118	09-009 053-89	47	12
527ACA		53	31	4021	09-400 786-00	53	17	5137	09-009 053-91	17	9
908	09-400 032-00	51	1	4022	09-400 787-00	53	14	51388	09-009 067-17	37	43
1174	09-009 067-44	7	19	4022	09-400 787-00	53	35	51388	09-009 067-17	39	56
1174	09-009 067-44	15	36	4022	09-400 787-00	53	14	5142	09-009 053-94	5	22
1174	09-009 067-44	47	43	4022	09-400 787-00	53	35	5142	09-009 053-94	9	11
1175-2	09-009 048-13	23	31	4117	09-400 787-00	53	33	5145	09-009 600-26	37	15
1175-2	09-009 048-13	27	25	4117	09-400 787-00	53	33	5146	09-009 053-95	5	11
1175-2	09-009 048-13	27	30	4117	09-400 788-00	49	5				

INDEX

PART NO.	PFAFF-NO	PAGE	NO. REF.	PART NO.	PFAFF-NO	PAGE	NO. REF.	PART NO.	PFAFF-NO	PAGE	NO. REF.
5184	09-009 054-02	47	4	5497	09-009 612-60	13	4	201880	09-009 813-83	17	11
5198	09-009 054-04	9	2	5501	09-009 618-31	17	37	202045	12-500 190-45	37	49
5205	09-009 069-93	27	42	5501	09-009 618-31	17	40	202045	12-500 190-45	39	63
5231	09-009 054-77	27	35	5503	09-009 732-59	35	8	202058	09-009 601-63	45	25
5238	09-009 067-49	29	22	5504	09-009 804-07	33	36	*202174	09-009 612-71	15	17
5276	09-009 601-09	49	23	5515	09-009 807-19	43	19	*202174	09-009 612-71	15	23
5282	09-009 612-36	19	33	5519	09-009 732-60	19	14	*202174	09-009 612-71	19	45
5284	09-009 067-39	21	3	5519	09-009 732-60	23	12	*202174	09-009 612-71	21	11
5284	09-009 067-39	21	14	5522	09-009 732-61	13	25	*202174	09-009 612-71	21	22
5292	09-009 064-89	9	36	5523	09-009 732-62	13	23	*202175	09-009 601-64	5	6
5292	09-009 064-89	15	16	5534	09-009 807-20	49	27	*202175	09-009 601-64	15	9
5292	09-009 064-89	15	22	5535	09-009 807-21	17	15	*202175	09-009 601-64	15	21
5292	09-009 064-89	17	22	5535	09-009 807-21	17	19	*202175	09-009 601-64	19	40
5292	09-009 064-89	17	24	5543	09-009 807-22	45	18	*202176	26-536 302-03	41	10
5292	09-009 064-89	19	37	5543	09-009 807-22	45	21	202199	17-518 010-51	37	25
5292	09-009 064-89	21	10	5543	09-009 807-22	45	23	202199	17-518 010-51	39	20
5292	09-009 064-89	21	21	5543	09-009 807-22	45	27	202199	17-518 010-51	39	28
5292	09-009 064-89	25	19	5543	09-009 807-22	45	31	202199	17-518 010-51	39	35
5292	09-009 064-89	25	56	5546	09-009 732-64	19	23	202286	09-009 051-75	19	19
5292	09-009 064-89	31	30	5546	09-009 732-64	23	22	202286	09-009 051-75	19	24
5292	09-009 064-89	35	12	5568	09-009 732-65	29	28	202286	09-009 051-75	23	19
5292	09-009 064-89	35	21	5589	09-009 732-66	9	20	202286	09-009 051-75	23	23
5299	09-009 067-14	35	27	5594	09-009 732-67	31	16	202286	09-009 051-75	47	13
5316	09-009 601-16	25	26	5594	09-009 732-67	31	22	202287A	09-009 051-76	37	44
5316	09-009 601-16	31	19	5594	09-009 732-67	31	27	202287A	09-009 051-76	39	57
5317	09-009 601-17	27	18	5594	09-009 732-67	33	14	*202295	09-009 066-42	33	25
5328	09-009 071-11	5	10	5594	09-009 732-67	35	14	*202295	09-009 066-42	51	19
5328	09-009 071-11	13	2	5595	09-009 732-68	5	13	*202295	09-009 066-42	68	
5328	09-009 071-11	17	35	5596	09-009 732-69	35	16	*202295	09-009 066-42	69	
5328	09-009 071-11	35	31	5597	09-009 732-70	29	25	*202295	09-009 066-42	70	
5328	09-009 071-11	35	49	5597	09-009 732-70	33	20	*202295	09-009 066-42	71	
5328	09-009 071-11	43	16	7102	09-400 792-00	53	12	*202295	09-009 066-42	72	
5332A	09-009 813-11	5	28	7102	09-400 792-00	53	12	*202295	09-009 066-42	73	
5345	09-009 070-23	41	12	9029	09-009 734-85	49	2	*202295	09-009 066-42	74	
5346	09-009 068-79	27	9	9030	09-008 823-63	49	30	*202295	09-009 066-42	75	
5346	09-009 067-95	3	11	9050	09-009 815-93	49	13	202340	09-009 612-73	33	28
5357	09-009 067-95	11	33	137906	09-009 068-42	7	3	202451	09-009 051-81	35	24
5357	09-009 067-95	17	33	137906	09-009 068-42	9	40	202577	09-009 052-61	15	20
5376	09-009 612-37	11	5	167066	09-009 601-53	47	17	202645	09-009 054-98	35	41
5376	09-009 612-37	11	7	167066	09-009 601-53	47	20	202647A	09-009 065-79	35	46
5376	09-009 612-37	11	9	167066	09-009 601-53	47	27	202875	09-009 601-76	7	7
5376	09-009 612-37	11	13	167066	09-009 601-53	47	44	202875	09-009 601-76	19	15
5376	09-009 612-37	11	20	*179257-05	91-179 257-05	37	36	202875	09-009 601-76	23	13
5376	09-009 612-37	11	22	192130	09-009 612-66	7	14	204006	09-009 601-82	5	32
5376	09-009 612-37	11	24	198192	09-009 605-10	9	18	204010	14-018 570-01	13	5
5376	09-009 612-37	11	28	200136	09-009 054-86	37	22	204052A	09-009 064-62	25	30
5380	09-009 601-47	43	22	200136	09-009 054-86	39	18	204052A	09-009 064-62	31	13
5380	09-009 601-47	49	20	200136	09-009 054-86	39	26	204084-2	09-009 055-52	25	14
5408	09-009 070-03	19	35	200136	09-009 054-86	39	30	204107	09-009 067-58	23	17
5426	09-009 612-38	49	25	200144	09-009 612-67	39	33	204114	09-009 064-01	27	33
5427	09-009 611-79	25	18	200149	09-009 048-73	5	14	204115	09-009 064-02	27	22
5434A	09-009 823-62	5	29	200152	09-009 069-37	37	24	204115	09-009 064-02	27	34
5437	09-009 606-28	25	12	200152	09-009 069-37	39	19	204115	09-009 064-02	29	11
5441	09-009 601-52	23	15	200152	09-009 069-37	39	27	204115	09-009 064-02	31	34
5446	09-009 807-18	17	17	200152	09-009 069-37	39	31	204128A	09-009 601-83	27	14
5453	09-009 612-40	47	41	200155	09-009 069-37	39	34	204129A	09-009 601-84	27	12
5455	09-009 612-41	27	6	200155	09-009 065-56	41	9	204146	09-009 065-81	15	30
5457	09-009 612-42	11	11	200555	09-009 071-03	9	35	204184	09-009 067-19	39	7
5457	09-009 612-42	11	15	200555	09-009 071-03	43	30	204185	09-009 067-40	25	3
5457	09-009 612-42	11	26	201002	09-009 601-58	3	9	204185	09-009 067-40	37	16
5457	09-009 612-42	11	30	201022	09-009 049-09	31	14	204185	09-009 067-40	39	12
5457	09-009 612-42	15	28	201037	09-009 049-22	17	4	204274	09-009 064-69	21	8
5457	09-009 612-42	25	23	201056	09-009 049-35	15	6	204274	09-009 064-69	21	19
5457	09-009 612-42	25	28	201068	09-009 049-44	19	4	204293	09-009 602-07	13	26
5457	09-009 612-42	27	3	201086	09-009 049-57	23	4	204319	09-009 065-97	13	3
5457	09-009 612-42	27	8	201089	09-009 049-60	23	11	204439A	09-009 602-09	27	17
5457	09-009 612-42	33	10	*201121A	09-009 050-06	33	5	204466	09-009 607-37	41	4
5457	09-009 612-42	35	6	*201121A	09-009 050-06	68		204585	09-009 602-15	45	9
5461	09-009 612-44	13	13	*201121A	09-009 050-06	69		204657	09-009 812-08	19	10
5461	09-009 612-44	15	31	*201121A	09-009 050-06	70		204657	09-009 812-08	19	36
5461	09-009 612-44	25	7	*201121A	09-009 050-06	71		204657	09-009 812-08	23	10
5461	09-009 612-44	25	21	*201121A	09-009 050-06	72		204667	09-009 068-19	47	18
5461	09-009 612-44	33	12	*201121A	09-009 050-06	74		204737A	09-009 824-62	13	1
5476	09-009 612-45	53	3	*201121A	09-009 050-06	75		204754A	09-009 814-34	25	31
5476	09-009 612-45	53	3	*201121A	09-009 050-06	75		204756	09-009 068-26	25	33
5480	09-009 612-47	7	32	*201127	09-009 054-43	33	31	204757	09-009 068-27	25	34
5481	09-009 612-48	35	3	*201127	09-009 054-43	73		204888	09-009 602-49	43	23
5482	09-009 612-49	5	18	201156	09-009 050-20	35	54	205113A	09-009 820-16	37	23
5483	09-009 612-50	7	15	201185	09-009 050-38	7	11	205418	09-009 612-76	27	16
5484-HC	09-009 612-51	17	31	201185	09-009 050-38	25	47	205466A	09-009 823-66	49	1
5485	09-009 612-52	15	3	201185	09-009 050-38	31	5	205467	09-009 603-76	49	9
5486	09-009 612-53	25	38	201185	09-009 050-38	41	13	205468-JA	09-009 603-77	49	14
5486	09-009 612-53	31	7	201191	09-009 050-43	47	5	205469-JA	09-009 603-78	49	15
5488	09-009 612-54	23	29	201252	09-009 050-73	53	7	205470-JA	09-009 815-05	49	11
5488	09-009 612-55	7	22	201252	09-009 050-73						

INDEX

PART NO.	PF AFF-NO	PAGE	NO.	PART NO.	PF AFF-NO	PAGE	NO.	PART NO.	PF AFF-NO	PAGE	NO.
			REF.				REF.				REF.
210586	09-009 617-44	23	27	211360	09-009 732-96	70		212019	09-009 733-62	29	19
210679	09-009 617-74	5	26	211360	09-009 732-96	71		212020	09-009 733-63	29	21
210679	09-009 617-74	5	35	211360	09-009 732-96	72		212021	09-009 733-64	29	6
210680	09-009 617-75	47	2	211360	09-009 732-96	73		212025	09-009 733-65	29	3
210681	09-009 617-76	47	3	211360	09-009 732-96	74		212026	09-009 733-66	29	5
210682	09-009 617-77	47	7	211360	09-009 732-96	75		212028	09-009 733-67	27	1
210683	09-009 617-78	43	33	211361	09-009 801-05	71		212035	09-009 733-71	31	26
210683	09-009 617-78	47	9	211362	09-009 801-06	71		212036	09-009 733-72	29	9
210684	09-009 617-79	43	31	211369	09-009 732-97	37	29	212037	09-009 733-73	3	22
210684	09-009 617-79	47	10	211369	09-009 732-97	39	40	212038	09-009 733-74	3	23
210685	09-009 617-80	47	1	211385	09-009 732-98	3	10	212039	09-400 152-00	31	29
210686	09-009 617-81	47	14	211389-CD	09-009 823-82	5	9	212042	09-009 733-78	31	10
210687	09-009 617-82	47	15	211392	09-009 733-04	17	32	212047	09-009 733-80	35	17
210700	09-009 617-93	25	43	211401	09-009 734-97	23	36	212048	09-009 733-81	3	7
210701	09-009 732-83	39	21	211507	09-009 801-60	69		212049	09-009 733-82	35	18
210721	09-009 618-55	19	49	211507	09-009 801-60	70		212050	09-009 733-83	35	5
210724	09-009 618-30	17	36	211507	09-009 801-60	72		212052	09-009 733-85	35	13
210724	09-009 618-30	68		211507	09-009 801-60	73		212068	09-009 733-95	75	
210724	09-009 618-30	68		211507	09-009 801-60	74		212069	09-009 733-96	35	50
210724	09-009 618-30	70		211526	09-009 733-09	13	14	212070-BF	09-009 733-97	75	
210724	09-009 618-30	71		211527	09-009 733-10	13	10	212133	09-009 734-04	75	
210724	09-009 618-30	72		211528	09-009 733-11	13	18	212140	09-009 734-05	29	33
210724	09-009 618-30	73		211529	09-009 733-12	13	15	212143	09-009 734-06	29	34
210724	09-009 618-30	74		211530	09-009 733-13	13	12	212144	09-009 734-07	29	8
210724	09-009 618-30	75		211531	09-009 733-14	37	3	212145	09-009 734-08	29	7
210725	09-009 618-33	23	28	211531	09-009 733-14	39	3	212146	09-009 734-09	29	35
210728	09-009 617-96	35	11	211533	09-009 733-15	3	14	212147	09-009 734-10	29	36
210731	09-009 618-51	11	14	211557	09-009 732-30	35	56	212148	09-009 734-11	39	1
210731	09-009 618-51	11	29	211636	09-009 733-16	35	1	*212149	09-009 734-12	39	9
210734	09-009 618-53	11	25	211639	09-009 733-18	41	8	212152	09-009 734-13	37	32
210744	09-009 618-37	39	32	211649	09-009 733-19	15	29	212152	09-009 734-13	39	45
210750	09-009 618-26	17	25	211652	09-009 733-21	11	10	212153	09-009 734-14	37	33
210751	09-009 618-49	17	26	211654-T	09-009 824-65	21	5	212153	09-009 734-14	39	46
210756	09-009 804-06	33	35	211654-T	09-009 824-65	21	16	212154	09-009 734-15	3	20
210758	09-009 804-08	33	37	211655	09-009 733-24	21	2	212179	09-009 734-32	25	57
210759	09-009 804-09	33	38	211657	09-009 733-25	35	45	212181-BF	09-009 734-33	75	
*210766	09-009 823-85	41	5	211698	09-009 733-28	9	49	*212186	09-009 734-34	15	5
210784	09-009 620-42	74		211698A	09-009 807-77	9	50	212188	09-009 734-35	37	30
210795	09-009 620-53	73		211698B	09-009 811-94	9	51	212188	09-009 734-35	39	42
210796	09-009 620-54	69		211702	09-009 733-30	9	31	212215	09-009 802-28	68	
210796	09-009 620-54	73		211719	09-009 733-31	68		212215	09-009 802-28	69	
210796	09-009 620-54	75		211719	09-009 733-31	69		212215	09-009 802-28	70	
210797	09-009 620-55	69		211719	09-009 733-31	70		212215	09-009 802-28	71	
210797	09-009 620-55	73		211719	09-009 733-31	72		212215	09-009 802-28	72	
210801	09-009 620-58	75		211719	09-009 733-31	73		212215	09-009 802-28	73	
210801	09-009 620-58	75		211719	09-009 733-31	74		212215	09-009 802-28	74	
210804	09-009 620-61	69		211719	09-009 733-31	75		212215	09-009 802-28	75	
210804	09-009 620-61	70		211720	09-009 802-26	71		212215A	09-009 807-89	71	
210804	09-009 620-61	73		211771	09-009 807-78	33	32	*212281A	09-009 824-91	5	34
210804	09-009 620-61	73		211771	09-009 807-78	71		212287	09-009 734-37	47	21
210804	09-009 620-61	74		211794	09-009 804-02	9	32	*212325-CD	09-009 824-81	3	12
210804	09-009 620-61	75		211799-CD	09-009 813-16	9	1	212400	09-009 734-38	29	13
210805	09-009 621-59	69		211800	09-009 804-39	9	5	212404	09-009 734-39	29	23
210805	09-009 621-59	70		211801	09-009 804-37	9	6	212405	09-009 734-40	29	26
210805	09-009 621-59	73		211802A	09-009 823-89	25	10	212408	09-009 734-42	33	13
210805	09-009 621-59	74		211804	09-009 733-33	25	11	212409	09-009 734-43	33	17
210805	09-009 621-59	75		211823	09-009 733-34	35	19	212410	09-009 734-44	33	19
210806	09-009 620-62	69		211840	09-009 733-35	9	47	212412A	09-009 807-93	15	14
210806	09-009 620-62	70		211844	09-009 733-36	69		212413	09-009 734-47	15	19
210806	09-009 620-62	73		211844	09-009 733-36	70		212416	09-009 734-48	31	1
210806	09-009 620-62	74		211844	09-009 733-36	71		212419	09-009 734-51	31	11
210806	09-009 620-62	75		211844	09-009 733-36	72		212420	09-009 734-52	35	22
210809	09-009 620-65	72		211844	09-009 733-36	73		212430	09-009 807-94	43	14
210809	09-009 620-65	75		211844	09-009 733-36	74		212431	09-009 807-95	43	18
210881	09-009 618-41	7	17	211844	09-009 733-36	75		212432	09-009 807-96	43	17
210883	09-009 618-42	7	1	211874-TA	09-009 807-79	75		212433	09-009 807-97	43	3
210898	09-009 618-27	17	41	211875-TA	09-009 801-93	75		212434	09-009 804-43	43	11
210922	09-009 819-06	17	39	211879	09-009 733-40	47	23	212435	09-009 804-44	43	10
210923	09-009 818-28	17	42	211880	09-009 733-41	43	46	212436	09-009 806-84	43	7
210928A91	09-009 823-87	21	12	211880	09-009 733-41	47	24	212436	09-009 806-84	45	10
210929A91	09-009 824-88	21	1	211926-T	09-009 824-67	21	4	212437	09-009 807-98	43	5
210930	09-009 618-32	17	38	211926-T	09-009 824-67	21	15	212438	09-009 734-53	35	26
210955	09-009 618-77	43	37	211929-BF	09-009 811-85	75		212439	09-009 734-54	35	28
211264	09-009 803-93	47	40	*211941	09-009 733-46	35	39	212440	09-009 734-55	29	1
211265	09-009 806-17	47	42	211946	09-009 733-47	43	47	212441	09-009 807-99	49	18
211300	09-009 732-85	7	4	211946	09-009 733-47	47	25	212442	09-009 808-01	49	19
211301	12-305 174-15	25	39	211949	09-009 733-48	43	49	212443	09-009 808-02	49	22
211301	12-305 174-15	31	8	211958	09-009 733-49	9	21	212444	09-009 808-03	49	26
*211313	09-009 820-19	9	7	211959-BD	09-009 813-18	9	19	212445	09-009 734-56	29	30
211314	09-009 732-87	25	48	211995	09-009 735-12	19	32	212446	09-009 734-57	29	31
211345ABD	09-009 824-89	13	22	212001-CD	09-009 823-92	3	1	212447	09-009 734-58	29	27
211358	09-009 732-95	17	20	212004ACD	09-009 824-90	5	8	212448	09-009 734-59	29	14
211358	09-009 732-95	68		212005	09-009 733-54	9	14	212449	09-009 734-60	29	15
211358	09-009 732-95	69		212006	09-009 733-55	9	12	*21			

PART NO.	PFAFF-NO	PAGE	NO. REF.	PART NO.	PFAFF-NO	PAGE	NO. REF.	PART NO.	PFAFF-NO	PAGE	NO. REF.
205764	09-009 612-87	49	7	210091	09-009 613-72	11	23	210199	09-009 614-63	39	38
205765	09-009 612-88	49	8	210091	09-009 613-72	11	27	210200	09-009 614-64	37	18
206128-2	09-009 612-90	27	39	210092	09-009 613-73	19	22	210200	09-009 614-64	39	14
206129	09-009 612-91	27	49	210092	09-009 613-73	23	21	210201-CD	09-009 814-80	37	19
206180	09-009 612-92	19	21	210093	09-009 613-74	19	25	210201-FD	09-009 815-71	39	15
206180	09-009 612-92	33	8	210093	09-009 613-74	23	24	210202	09-009 614-66	39	41
206233	09-009 070-13	37	17	210099	09-009 613-78	19	16	210204	09-009 614-68	39	44
206233	09-009 070-13	39	13	210100	09-009 613-79	19	17	210205	09-009 614-80	39	43
206233	09-009 070-13	51	18	210100	09-009 613-79	27	10	210206	09-009 732-79	39	22
206336	09-009 604-60	49	6	210101	09-009 613-80	3	15	210208	09-009 614-71	39	36
206337	09-009 612-93	49	10	210102	09-009 613-81	3	16	210211	09-009 614-73	37	42
206337	09-009 612-93	49	17	210102	09-009 613-81	3	28	210211	09-009 614-73	39	55
206431	09-009 070-62	37	20	210103	09-009 613-82	19	28	210212	09-009 614-74	37	47
206431	09-009 070-62	39	16	210104	09-009 613-83	21	13	210212	09-009 614-74	39	61
*206468	09-009 820-01	37	8	210105-2	09-009 824-77	21	9	210213	09-009 614-75	41	1
207341-JA	09-009 823-94	45	14	210105-2	09-009 824-77	21	20	210214	09-009 614-76	41	2
207344-JA	09-009 823-95	45	17	*210107	09-009 823-97	21	7	210215	09-009 614-77	41	6
207345-JA	09-009 823-96	45	26	*210107	09-009 823-97	21	18	210223	09-009 614-83	9	23
207346	09-009 807-35	45	28	210109	09-009 613-88	19	34	210225	09-009 614-85	9	30
207350-JA	09-009 824-63	45	20	210110	09-009 613-89	3	17	210228-PC	09-009 807-41	11	17
207924	09-400 145-00	35	7	210112A	09-009 824-64	19	46	210228-PD	09-009 807-40	11	2
208009	09-009 070-87	9	34	210113	09-009 613-92	19	47	210229	09-009 614-87	11	4
208168	09-009 604-71	27	45	210114	09-009 613-93	19	41	210229	09-009 614-87	11	19
208173	09-009 604-72	5	30	210115	09-009 613-94	19	42	210231	09-009 614-89	15	27
208173	09-009 604-72	19	38	210117	09-009 613-95	7	33	210232	09-009 614-90	15	13
208235	09-009 606-51	25	24	210118	09-009 613-96	19	39	210233	09-009 614-91	3	3
208235	09-009 606-51	27	40	210122	09-009 613-99	23	20	210234	09-009 614-92	3	2
208235	09-009 606-51	33	16	210123	09-009 614-00	23	16	210235	09-009 614-93	15	8
208245	09-009 612-96	7	24	210124	09-009 614-01	3	24	210236	09-009 614-94	15	11
208411	09-009 607-41	25	8	210125	09-009 614-02	3	25	210237A-2	09-009 614-95	15	15
208415	09-009 607-44	25	9	210127	09-009 614-04	25	15	210238-2	09-009 614-96	15	10
208447	09-009 607-58	17	2	210128A	09-009 815-66	25	20	210239	09-009 614-97	15	1
208447	09-009 607-58	19	2	210129	09-009 614-06	25	16	210240	09-009 614-98	15	2
208447	09-009 607-58	23	2	210130	09-009 614-07	25	17	210241	09-009 614-99	15	4
208448	09-009 607-59	17	3	210136	09-009 614-11	25	6	210242	09-009 615-00	3	4
208448	09-009 607-59	19	3	210137	09-009 614-12	25	1	210264	09-009 615-20	17	12
208448	09-009 607-59	23	3	210138	09-009 614-13	25	4	210267	09-009 615-22	19	20
208449	09-009 607-60	17	7	210139	09-009 614-14	25	2	210297	09-009 615-49	3	21
208449	09-009 607-60	19	7	210140	09-009 614-15	25	13	210314	09-009 615-64	33	9
208449	09-009 607-60	23	7	210141A	09-009 807-39	25	22	210319	09-009 615-68	17	6
208450	09-009 607-61	17	5	210143	09-009 614-18	3	27	210319	09-009 615-68	19	6
208450	09-009 607-61	19	5	210144	09-009 614-19	27	2	210319	09-009 615-68	23	6
208450	09-009 607-61	23	5	210145	09-009 614-20	27	4	210323	09-009 615-71	35	20
208525-B	09-009 807-37	35	48	210146	09-009 614-21	27	5	210328	09-009 615-75	29	2
208537	09-009 607-73	35	38	210147	09-009 614-22	27	20	210335	09-009 615-80	35	4
208579	09-009 612-98	33	2	210148	09-009 614-23	27	21	210343	09-009 615-87	27	24
208592	09-009 607-92	19	44	210148	09-009 614-23	29	10	210349	09-009 615-93	19	11
208599	09-009 607-95	35	43	210148	09-009 614-23	31	32	210350	09-009 615-94	19	13
208687	09-009 732-77	39	5	210152	09-009 614-24	27	7	210353	09-009 615-97	23	35
208744	09-009 817-02	9	28	210153	09-009 614-25	27	32	210365	09-009 616-04	68	
208747	09-009 603-37	9	26	210154	09-009 614-26	27	19	210365	09-009 616-04	69	
208774	09-009 612-99	35	40	210155	09-009 614-27	27	31	210365	09-009 616-04	70	
209287	09-009 807-38	45	19	210156	09-009 614-28	27	38	210365	09-009 616-04	72	
210002	09-009 613-02	5	4	210157	09-009 614-29	27	41	210365	09-009 616-04	73	
210003	09-009 613-03	5	31	210158	09-009 614-30	27	43	210365	09-009 616-04	74	
210003	09-009 613-03	5	33	210159	09-009 614-31	27	48	210366	09-009 620-33	68	
210005	09-009 613-04	5	23	210160	09-009 614-32	27	46	210366	09-009 620-33	69	
210006	09-009 613-05	7	31	210161	09-009 614-33	25	25	210366	09-009 620-33	73	
210007	09-009 613-06	7	29	210162	09-009 614-34	25	27	210366	09-009 620-33	74	
210020	09-009 613-12	7	13	210163	09-009 614-35	25	29	210371	09-009 616-07	75	
210021	09-009 618-04	7	21	210164	09-009 614-36	3	26	210374	09-009 616-10	75	
210022	09-009 613-13	7	2	210166	09-009 614-37	25	35	210445-BF	09-009 616-58	75	
210022	09-009 613-13	7	27	210167	09-009 614-38	25	37	210503	09-009 617-03	75	
210023	09-009 613-14	7	23	210167	09-009 614-38	31	6	*210510	09-009 617-04	37	39
210024	09-009 613-15	7	5	210168	09-009 614-39	25	40	*210510	09-009 617-04	39	52
210025	09-009 613-16	7	8	210170	09-009 614-40	25	41	210511	09-009 617-05	15	25
210025	09-009 613-16	7	12	210171	09-009 614-41	25	45	210517	09-009 617-09	35	36
210025	09-009 613-16	7	28	210171	09-009 614-41	31	3	210520	09-009 617-12	37	50
210026-CB	09-009 824-87	7	18	210172	09-009 614-42	25	51	210520	09-009 617-12	39	58
210027-CB	09-009 824-75	7	9	210173	09-009 614-43	11	6	210521	09-009 617-13	37	45
210028-CB	09-009 815-10	9	8	210173	09-009 614-43	11	21	210521	09-009 617-13	39	59
210035	09-009 613-27	9	4	210175	09-009 614-45	33	11	210523	09-009 617-14	49	4
210042	09-009 613-31	9	33	210178A	09-009 814-56	33	3	210528	09-009 617-16	5	15
210043	09-009 613-32	9	37	210179	09-009 614-49	33	21	210529-BA	09-009 812-91	17	1
210044	09-009 613-33	9	45	210180	09-009 614-50	33	23	210529-BA	09-009 812-91	17	10
210045	09-009 613-34	9	43	210183	09-009 614-51	33	29	210530-BA	09-009 812-90	23	1
210046	09-009 613-35	9	41	210184	09-009 614-52	33	26	210531-BA	09-009 812-92	19	1
210047	09-009 613-36	9	38	*210188	09-009 614-55	39	2	210532	09-009 617-20	25	55
210055	09-009 613-43	13	20	210190	09-009 614-57	37	28	210533	09-009 617-21	25	54
210056	09-009 613-44	13	16	210190	09-009 614-57	39	39	210534	09-009 617-22	25	52
210057	09-009 613-45	3	5	*210191		39	49	210535	09-009 617-23	25	50
210057	09-009 613-45	13	17	*210192	09-009 614-59	37	37	210539	09-009 617-25	41	11
210058	09-009 613-46	13	21	*210192	09-009 614-59	39	50	210569-BF	91-009 812-25	74	
210062	09-009 613-49	13	7	210193	09-009 614-60	37	35	210574-BF	09-009 617-32	69	
210067	09-009 613-54	3	19	210193	09-009 614-60	39	48	210574-BF	09-009 617-32	70	
210068	09-009 613-55	3	18	210194	09-009 614-61	37	38	210574-BF	09-009 617-32	73	
210069	09-009 613-56	15	24	210194	09-009 614-61	39	51	210574-BF	09-009 617-32	74	
210069	09-009 613-56	33	7	210198	09-009 614-62	37	26	210574-BF	09-009 617-32	75	
210091	09-009 613-72	11	8	210198	09-009 614-62	39	37	210585	09-009 617-43	19	26
210091	09-009 613-72	11	12	210199	09-009 614-63	37	27	210585	09-009 617-43	23	26

Notice) Parts with mark * are not for sale

PART NO.	PFAFF-NO	PAGE	NO. REF.	PART NO.	PFAFF-NO	PAGE	NO. REF.	PART NO.	PFAFF-NO	PAGE	NO. REF.
212484	09-009 808-08	45	11	212764-50	09-009 808-88	73					
212485	09-009 808-09	45	16	212766-30	09-009 808-89	73					
212486	09-009 806-34	45	22	212766-30	09-009 808-89	74					
212487	09-009 808-10	45	13	212766-40	09-009 808-90	73					
*212489ACD	09-009 823-70	5	7	212766-40	09-009 808-90	74					
212492	09-009 808-11	45	29	212766-50	09-009 808-91	73					
212493-JA	08-009 823-71	45	30	212766-50	09-009 808-91	74					
212502	09-009 804-45	23	34	212766A30	09-009 808-92	74					
212503	09-009 804-31	17	28	212766A50	09-009 808-93	74					
212504	09-009 804-32	17	27	212766A50	09-009 808-94	74					
212572-BF	09-009 804-50	69		212768-10F	09-009 808-95	73					
212572-BF	09-009 804-50	70		212768-10F	09-009 808-95	74					
212572-BF	09-009 804-50	73		212774-40	09-009 809-01	71					
212572-BF	09-009 804-50	74		212774-50	09-009 809-02	71					
212600	09-009 808-23	43	13	212778B25	09-009 824-70	71					
212601	09-009 808-24	43	21	212778B35	09-009 824-71	71					
212602	09-009 808-25	43	29	212778B45	09-009 824-72	71					
212603	09-009 808-26	43	34	212781	09-009 613-61	69					
212604	09-009 808-27	43	25	212781	09-009 613-61	70					
212606	09-009 806-39	43	27	212781	09-009 613-61	71					
212607	09-009 808-28	43	28	212781	09-009 613-61	72					
212609-91	09-009 808-29	9	16	212781	09-009 613-61	73					
212634	09-009 808-30	37	41	212781	09-009 613-61	74					
212634	09-009 808-30	39	54	212781	09-009 613-61	75					
212644	09-009 804-51	68		212785	09-009 804-83	15	34				
212644	09-009 804-51	69		212786-91	09-009 804-84	15	35				
212644	09-009 804-51	70		*212821-CD		3	13				
212644	09-009 804-51	72		212938	09-009 824-05	43	42				
212644	09-009 804-51	73		212939	09-009 824-06	43	43				
212644	09-009 804-51	74		212972A91	09-009 820-02	37	1				
212644	09-009 808-32	31	21	*212976	09-009 820-03	37	2				
212650	09-009 804-52	31	31	212978-91	09-009 820-04	37	5				
212651	09-009 808-35	31	18	*212979	09-009 820-05	37	6				
212652	09-009 804-53	31	15	*212980	09-009 820-06	37	7				
212653	09-009 808-34	31	24	212981	09-009 820-07	37	9				
212655	09-009 808-34	43	1	212983-91	09-009 820-08	37	10				
212655	09-009 808-34	43	2	212987	09-009 820-09	13	11				
212655A91	08-009 824-01	43	2	212998	09-009 823-74	37	31				
212657B	09-009 808-38	11	16	213222A	09-009 823-75	33	1				
212658	09-009 804-54	43	40	213513	09-009 824-73	68					
212658A	09-009 824-02	43	45								
212659	09-009 806-38	43	35	213514-30	09-009 823-23	68					
212660	09-009 808-39	43	38	213514-40	09-009 824-47	68					
212668	09-009 804-59	35	58	213514-50	09-009 824-48	68					
212669A	09-009 808-43	35	32	213542-30	09-009 824-49	68					
212670B	09-009 808-44	11	1	213542-40	09-009 824-50	68					
212673-30	09-009 804-62	68		213548-40	09-009 823-38	68					
212673-30	09-009 804-62	69		213548-50	09-009 824-51	68					
212673-40	09-009 804-63	68		213550-13F	09-009 824-52	71					
212673-40	09-009 804-63	69		213567-16F	09-009 824-53	71					
212673-50	09-009 804-64	69		213570-10F	09-009 824-54	68					
212673A30	09-009 808-45	70		213571-16F	09-009 824-55	68					
212673A40	09-009 808-46	70		213572-16F	09-009 824-56	68					
212673A50	09-009 808-47	70		213573-16F	09-009 824-57	68					
212673B30	09-009 824-43	71		213574-13F	09-009 824-57	68					
212673B40	09-009 824-44	71		213575-13F	09-009 824-58	68					
212673B50	09-009 824-45	71		213576-30	09-009 824-59	68					
212677-10F	09-009 804-65	68		213576-40	09-009 824-60	68					
212677-10F	09-009 804-65	69		213576-50	09-009 824-61	68					
212677-10F	09-009 804-65	70		213578A	09-009 823-78	37	11				
212677-10F	09-009 804-65	72		213579	09-009 823-79	37	12				
212677A10F	09-009 824-46	71		*230047	09-400 154-00	5	25				
212704-13F	09-009 804-74	74		240052	91-179 447-05	5	5				
212705	09-009 808-60	35	47	240102	09-400 167-00	13	6				
212719A	09-009 808-61	35	35	240148	09-009 813-80	15	18				
212721	09-009 804-75	17	16	240172	09-009 814-64	35	10				
212722	09-009 808-63	17	44	252531	09-400 264-00	31	20				
212722A	09-009 808-62	17	18	300248	09-009 070-98	33	34				
212723	09-009 808-65	17	43	301373	09-009 802-27	68					
212723A	09-009 808-64	17	14	303067	12-501 170-45	49	24				
212726	09-009 804-78	23	32	303487	09-009 734-75	37	34				
212727	09-009 806-47	23	14	303487	09-009 734-75	39	47				
212728	09-009 806-89	19	29	307003	09-009 734-76	29	29				
212730-30	09-009 808-66	71		307003	09-009 734-76	31	17				
212730-40	09-009 808-67	71		307003	09-009 734-76	31	23				
212730-50	09-009 808-68	71		307003	09-009 734-76	31	28				
212731-25	09-009 808-71	71		307003	09-009 734-76	33	15				
212731-35	09-009 808-72	71		307003	09-009 734-76	35	15				
212731-45	09-009 808-73	71		9A3001	09-009 807-24	5	2				
212736-50	09-009 808-75	72		9A3002	09-009 814-81	37	51				
212738-40	09-009 808-76	72									
212740-13F	09-009 808-77	72									
212757-40	09-009 811-95	69									
212757-50	09-009 808-83	69									
212759-16F	09-009 808-84	72									
212759-16F	09-009 808-84	75									
212760-13F	09-009 806-92	68									
212761-40	09-009 804-82	74									
212763-10F	09-009 808-85	74									
212764-30	09-009 808-86	73									
212764-40	09-009 808-87	73									

Notice! Parts with mark ※: are not for sale.