

brother

SL-2110

零部件表 PARTS LIST

单针自动切线平缝机 SINGLE NEEDLE STRAIGHT LOCK STITCHER WITH THREAD TRIMMER

型号牌的读解法 Description of model plate

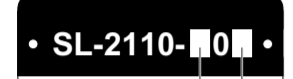

- 3 用于中厚布料
Medium-weight materials
- 5 用于厚布料
Heavy-weight materials
- 3 切线 + 倒缝
Thread Trimmer + Quick Reverse
- 4 切线 + 倒缝 + 扫线
Thread Trimmer + Quick Reverse + Thread Wiper

1. 本手册是根据截止至 2006 年 9 月的资料为基准而编制的。
2. 零部件设计若有变动, 恕不另行通知。
3. 以组件为单位供应的零部件是用虚线框出。
4. 在图中数字后带有 “+” 符号的是指由于机种不同其零部件也不同, 请参考相关的零部件表。
5. 零部件表中的零部件序号中有 “Ga.” 时, 由于机种不同其零部件也不同, 请参考 “Ga. 工模具一览表”。

1. This list was prepared based on information available in September 2006.
2. Parts are subject to changes in design without prior notice.
3. Parts supplied as complete assemblies are circled by a dotted line.
4. If the symbol “+” is found at the end of number in the figuree, refer to the parts list, because specification differs.
5. If the symbol “Ga.” is found in CODE column in list, refer to item the “Ga. Gauge parts list”, because specification differs.

A. 机体部分 / Machine body

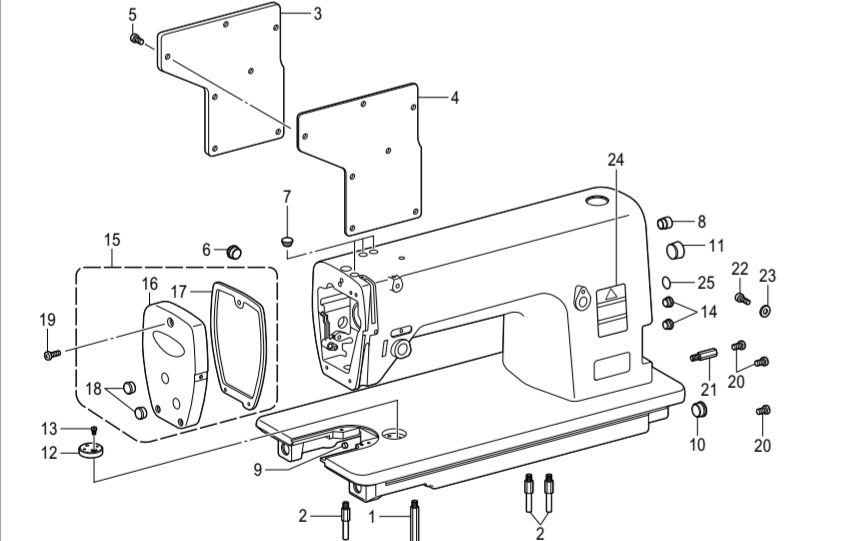

参照号	零部件序号	数量	零部件名称	NAME OF PARTS
1	104829121	1	机壳长支撑杆	BED LEG, L
2	104830121	3	机壳短支撑杆	BED LEG, S
3	S39560121	1	后盖板	SIDE PLATE
4	S02605000	1	后盖板垫片	REAR COVER PACKING
5	062681012	7	螺钉 SM3.37-40X10	SCREW PAN SM3.37-40X10
6	104449001	1	橡皮塞 15.5	RUBBER CAP, 15.5
7	104450101	3	橡皮塞 8	RUBBER CAP, 8
8	104832001	1	橡皮塞 10.7	RUBBER CAP, 10.7
9	142274101	1	橡皮塞 4.2	RUBBER CAP, 4.2
10	108520001	1	橡皮塞 19.8	RUBBER CAP, 19.8
11	104451101	1	橡皮塞 23.9	RUBBER CAP, 23.9
12	SA8137001	1	定位板	RULER PLATE
13	062670612	1	螺钉 SM3.57-40X6	SCREW PAN SM3.57-40X6
14	104450101	2	橡皮塞 8	RUBBER CAP, 8
15	SA8138001	1	面板组件	FACE PLATE ASSY
16	SA8139001	1	面板	FACE PLATE
17	SA8140001	1	面板垫片	FACE PLATE PACKING
18	104449001	2	橡皮塞 15.5	RUBBER CAP, 15.5
19	062671212	3	螺钉 SM3.57-40X12	SCREW PAN SM3.57-40X12
20	062760812	3	螺钉 SM5.95-28X8	SCREW PAN SM5.95-28X8
21	157969021	1	螺母	STUD
22	062680812	1	螺钉 SM4.37-40X8	SCREW PAN SM4.37-40X8
23	100645003	1	垫圈	WASHER
24	SA2041001	1	操作注意标签 (中/英)	LABEL, CAUTION CHINESE/ENGLISH
25	S37060021	1	接地标记	LABEL, GROUNDING

B. 针杆·挑线杆装置 / Needle bar and thread take-up mechanism

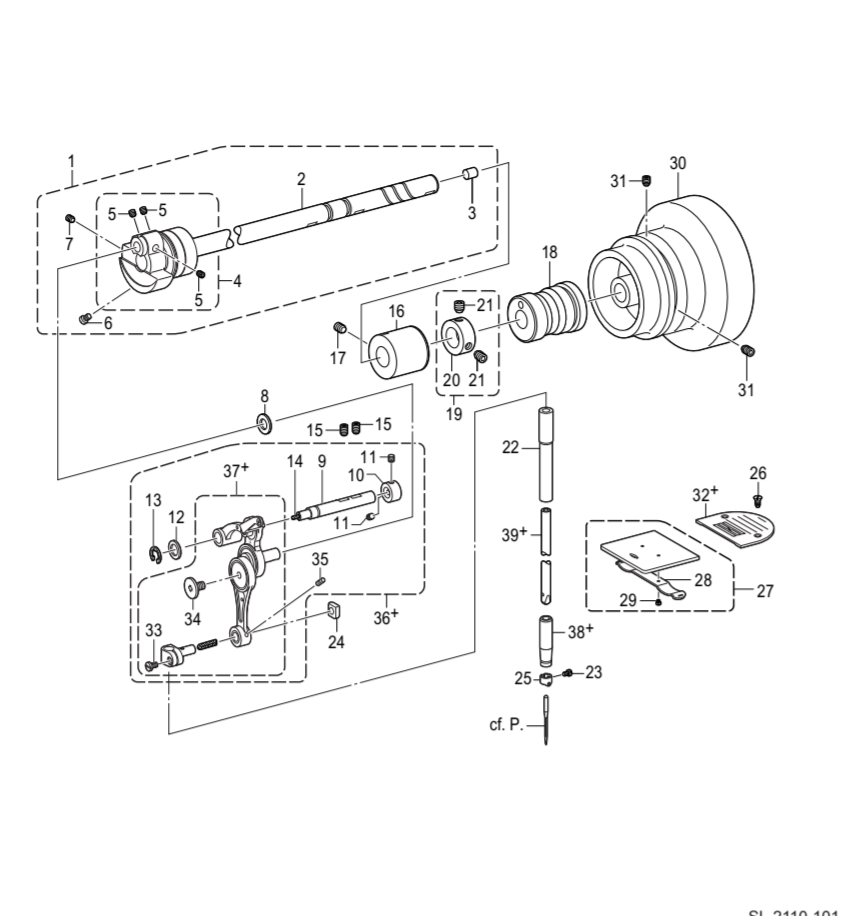

参照号	零部件序号	数量	零部件名称	NAME OF PARTS
1	SA8141001	1	上轴组件	UPPER SHAFT ASSY
2	SA8142001	1	上轴	UPPER SHAFT
3	156641001	1	橡皮塞 7.4	RUBBER CAP, 7.4
4	SA8143001	1	挑线杆曲柄组件	THREAD TAKE-UP CRANK ASSY
5	014770632	3	螺钉 SM6.35-40X6	SET SCREW SOCKET SM6.35-40X6
6	104449001	1	螺母 SM7.14-28	SCREW, SM7.14-28
7	014771032	1	固定螺钉 SM6.35-40X10	SET SCREW SOCKET SM6.35-40X10
8	SA8145001	1	垫圈	WASHER
9	SA1124001	1	挑线杆支撑杆	THREAD TAKE-UP SUPPORT SHAFT
10	SA1125001	1	紧圈	SET SCREW COLLAR
11	012400432	2	螺钉 M4X4	SET SCREW SOCKET (FT) M4X4
12	SA2181001	1	垫圈	WASHER
13	048080342	1	挡圈 E6	RETAINING RING E6
14	S32958000	1	油毡	WICK
15	014761030	2	螺钉 SM5.95-28X10	SET SCREW SOCKET SM5.95-28X10
16	SA8146001	1	上轴轴套 M	UPPER SHAFT BUSH M
17	014760632	1	螺钉 SM5.95-28X6	SET SCREW SOCKET SM5.95-28X6
18	S02562401	1	上轴右轴套	UPPER SHAFT BUSH, R
19	SA8147001	1	紧圈组件	SET SCREW COLLAR ASSY
20	147763121	1	上轴紧圈	SET SCREW COLLAR
21	014770632	2	螺钉 SM6.35-40X6	SET SCREW SOCKET SM6.35-40X6
22	SA8148001	1	针杆上轴套	NEEDLE BAR BUSH U
23	140553102	1	固定螺钉 SM3.18	SET SCREW, SM3.18
24	102630021	1	针杆接头滑块	NEEDLE BAR THREAD GUIDE SLIDE BLOCK
25	151594001	1	针杆过线环	NEEDLE BAR THREAD GUIDE
26	100032004	2	平头螺钉 SM4.37-40X8	SCREW, FLAT SM4.37-40X8
27	180018151	1	推板组件	SLIDE PLATE ASSY
28	114561001	1	推板簧	SPRING, PLATE
29	122771032	1	螺钉 SM2.38	SCREW, SM2.38
30	S02538129	1	主动轮	PULLEY
31	014761030	2	螺钉 SM5.95-28X10	SET SCREW SOCKET SM5.95-28X10
32	* Ga.	1	针板	NEEDLE PLATE
33	140004001	1	螺钉 SM3.57-40X7	SCREW, SM3.57-40X7
34	SA2422001	1	螺钉 SM3.57-40X6L	SCREW, SM3.57L
35	SA8436001	1	油毡	FELT
36	SA8017001	1	<用于-003> 针杆连接杆总组件	<For -003> NEEDLE BAR CONNECTING ROD UNIT
37	SA8018001	1	针杆连接杆	NEEDLE BAR CONNECTING ROD ASSY
38	SA8149001	1	针杆下轴套	NEEDLE BAR BUSH D
39	S58891001	1	针杆 DB <用于 DB 针>	NEEDLE BAR, DB <用于 DB 针>
39	S58892001	1	针杆 DP <用于 DP 针>	NEEDLE BAR, DP <用于 DP 针>
36	SA8023001	1	<用于-005> 针杆连接杆总组件	<For -005> NEEDLE BAR CONNECTING ROD UNIT
37	SA8024001	1	针杆连接杆	NEEDLE BAR CONNECTING ROD ASSY
38	SA8182001	1	针杆下轴套	NEEDLE BAR BUSH D
39	SA8183001	1	针杆	NEEDLE BAR

C. 倒缝开关装置 / Quick reverse switch mechanism

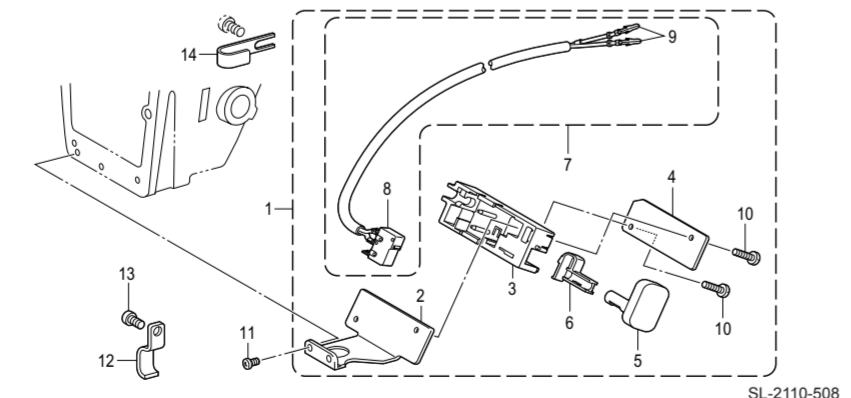

参照号	零部件序号	数量	零部件名称	NAME OF PARTS
1	SA8190001	1	R-调节器组件	REVERSE ACTUATOR ASSY
2	SA8191001	1	R-开关支撑	REVERSE SWITCH SUPPORT
3	SA7295001	1	倒缝开关安装架	REVERSE SWITCH BRACKET
4	SA8192001	1	R-开关盖	REVERSE SWITCH COVER
5	SA4098101	1	按钮	ACTUATOR
6	SA4099001	1	R-开关弹簧	REVERSE SWITCH SPRING
7	S32906000	1	R-开关组件	REVERSE SWITCH ASSY
8	S32907000	1	微动开关	MICRO SWITCH
9	143549000	2	接头插针	TERMINAL PIN, MALE
10	002201203	2	螺钉 M3X12	SCREW, PAN M3X12
11	062670612	2	螺钉 SM3.57-40X6	SCREW PAN SM3.57-40X6
12	SA8193001	1	电线夹 UZ	CORD HOLDER UZ
13	062670612	2	螺钉 SM3.57-40X6	SCREW PAN SM3.57-40X6
14	S02704021	1	电线夹	CORD HOLDER
1	S02554021	1	送布连杆	LEVEL FEED CONNECTING ROD
2	156948021	1	送布连杆挡圈	HOLDER
3	108960002	2	螺钉 SM3.57	SCREW, FLAT SM3.57
4	S05898121	1	针距调节器组件	LEVEL FEED REGULATOR ASSY
5	156950220	1	针距调节器	LEVEL FEED REGULATOR
6	156951021	2	曲柄连杆短销	FEED LINK STUD
7	014680632	2	螺钉 SM4.37-40X6	SET SCREW SOCKET SM4.37-40X6
8	156952021	1	曲柄连杆短销	FEED ROCKER LINK ASSY
9	156954021	1	曲柄长连杆组件	FEED ROCKER ARM LINK ASSY
10	156956021	1	曲柄长连杆销	LINK SHAFT
11	144458001	1	螺钉 SM3.57-40X4.5	SET SCREW SOCKET SM3.57-40X4.5
12	156957120	1	送布曲柄	FEED ROCKER ARM
13	062711412	1	螺钉 SM4.76-32X14	SCREW PAN SM4.76-32X14
14	156958021	1	送布曲柄销	FEED ROCKER ARM SHAFT
15	014680632	1	螺钉 SM4.37-40X6	SET SCREW SOCKET SM4.37-40X6
16	158021122	1	针距调节器连杆组件	F-REGULATOR CONNECT. ROD ASSY
17	15696121	1	偏心销	PIN
18	048060342	1	挡圈 E6	RETAINING RING E6
19	120990001	1	螺钉 SM4.37-40X8	SET SCREW, (CP) SM4.37-40X8
20	156967121	1	针距调节轴 L	FEED REGULATOR SHAFT, L
21	118734021	1	针距调节器轴套	FEED REGULATOR SHAFT WASHER
22	118735021	1	垫圈	WASHER
23	014760632	2	螺钉 SM5.95-28X6	SET SCREW SOCKET SM5.95-28X6
24	156969121	1	针距座	LEVEL FEED REGULATOR SHAFT WASHER
25	156970021	1	垫圈	WASHER
26	S02556021	1	垫圈	WASHER
27	048070342	1	挡圈 E7	RETAINING RING E7
28	014761030	1	螺钉 SM5.95-28X10	SET SCREW SOCKET SM5.95-28X10
29	151308121	1	连杆轴 12.5	STUD, 12.5
30	SA7264001	1	固定螺钉 SM4.37-40X4	SET SCREW, SOCKET (CP) SM4.37-40X4
31	S02557120	1	侧轴轴套	LEVER
32	S07959001	1	螺钉 SM4.76-32X14	BOLT, SOCKET SM4.76-32X14
33	151308121	1	连杆轴 12.5	STUD, 12.5
34	SA7264001	1	固定螺钉 SM4.37-40X4	SET SCREW, SOCKET (CP) SM4.37-40X4
35	SA8195001	1	倒缝换线杆组件	REVERSE STITCHING LEVER ASSY
36	S02561001	1	拉簧销	SPRING HOOK PIN
37	S33681001	1	倒缝换线轴	SHAFT, R-LEVER
38	147504221	1	挡圈	SPACER
39	025100132	1	平垫圈 S10	WASHER PLAIN S 10
40	048080342	1	挡圈 E8	RETAINING RING E8
41	S33680001	1	O 型密封圈	O RING
42	062670712	3	螺钉 SM3.57-40X7	SCREW PAN SM3.57-40X7
43	S02562021	1	拉簧钩	SPRING HOOK
44	S02563001	1	复位圈	SPRING, EXTENSION
45	153132020	1	尼龙管 L=13.5	NYLON TUBE, L=13.5
46	145502021	1	定位销	POSITIONING PIN
47	100328001	1	止动弹簧	NOTCH SPRING
48	S02568121	1	送布轴	FEED ROCKER SHAFT
49	S31014020	1	轴套 19.3	BUSH 19.3
50	156243021	1	送布轴轴套垫圈	THRUST RING
51	048150142	1	轴用挡圈 C15	RETAINING RING EXTERNAL C15
52	SA8150001	1	紧圈组件	SET SCREW COLLAR ASSY
53	014770632	2	螺钉 SM6.35-40X6	SET SCREW SOCKET SM6.35-40X6
54	156244020	1	牙架曲柄	FEED ROCKER BRACKET ARM
55	062681212	2	螺钉 SM4.37-40X12	SCREW PAN SM4.37-40X12
56	S02569121	1	牙架组件	FEED BAR ASSY
57	S02573020	1	垫圈	WASHER
58	S25349021	1	牙架曲柄偏心轴	FEED BAR STUD
59	158722021	1	垫圈 4.2	WASHER PLAIN 4.2
60	120990001	2	螺钉 SM4.37-40X8	SET SCREW, (CP) SM4.37-40X8
61	100080004	2	螺钉 SM3.18-44X5.5	SCREW, SM3.18-44X5.5
62	S02574121	1	抬牙轴	FEED LIFTING ROCKER SHAFT
63	S31014020	1	轴套 19.3	BUSH 19.3
64	156243021	1	送布轴轴套垫圈	THRUST RING
65	048150142	1	轴用挡圈 C15	RETAINING RING EXTERNAL C15
66	180322021	1	抬压叉组件	FEED LIFTING ARM ASSY
67	062681412	1	螺钉 SM4.37-40X14	SCREW PAN SM4.37-40X14
68	SA8157001	1	紧圈组件	SET SCREW COLLAR ASSY
69	014770632	2	螺钉 SM6.35-40X6	SET SCREW SOCKET SM6.35-40X6
70	S02575020	1	牙架曲柄	F-LIFTING ROCK SHAFT CRANK
71	062711212	1	螺钉 SM4.76-32X12	SCREW PAN SM4.76-32X12
72	147509021	1	螺钉 SM7.14	SCREW, SM7.14
73	104680002	1	螺母 SM7.14	NUT 7.14
74	118758021	1	抬牙连杆	CONNECTING ROD, V-FEEDING
75	156990021	1	上轴紧圈挡板	FEED CAM STOPPER
76	062670412	1	螺钉 SM3.57-40X4	SCREW PAN SM3.57-40X4
77	S02578121	1	倒缝换线杆限位板	REVERSE STITCHING LEVER PLATE
78	100511023	1	螺栓 SM4.76	SCREW, SM4.76
79	S04228001	1	针距座拉簧环	SPRING HOOK
80	* Ga.	1	送布牙	FEED DOG
81	014761030	2	螺钉 SM5.95-28X10	SET SCREW SOCKET SM5.95-28X10
82	S21514221	1	螺钉 SM4.76	SCREW, SM4.76
83	108549001	1	O 形圈	O RING
84	014760632	2	螺钉 SM5.95-28X6	SET SCREW SOCKET SM5.95-28X6
85	047200642	1	弹簧销 AW2	PIN SPRING ROLL AW2
86	SA8155001	1	<用于-003> 水平偏心轮 (带螺钉)	<For -003> LEVEL FEED ECCENTRIC WHEEL W/IS
87	S02558201	1	拉簧	EXTENSION SPRING
88	S31015021	1	针距标盘组件	STITCH LENGTH DIAL ASSY
89	SA8158001	1	上下偏心轮组件	F-LIFT ECCENTRIC WHEEL W/ISCREW
86	SA8184001	1	<用于-005> 水平偏心轮 (带螺钉)	<For -005> LEVEL FEED ECCENTRIC WHEEL W/IS
87	S03818101	1	拉簧 H	EXTENSION SPRING, H
88	S31018021	1	针距标盘组件	STITCH LENGTH DIAL ASSY 5
89	SA8185001	1	上下偏心轮组件	F-LIFT ECCENTRIC WHEEL W/ISCREW

D. 送料装置 / Feed mechanism

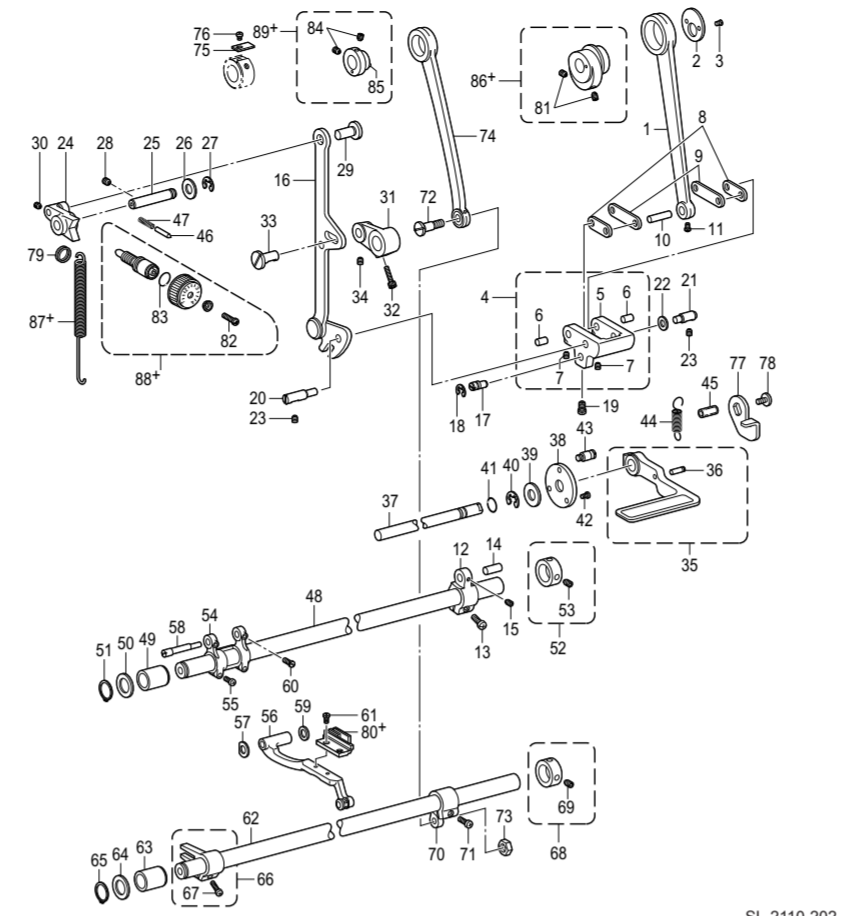

参照号	零部件序号	数量	零部件名称	NAME OF PARTS
1	S02554021	1	送布连杆	LEVEL FEED CONNECTING ROD
2	156948021	1	送布连杆挡圈	HOLDER
3	108960002	2	螺钉 SM3.57	SCREW, FLAT SM3.57
4	S05898121	1	针距调节器组件	LEVEL FEED REGULATOR ASSY
5	156950220	1	针距调节器	LEVEL FEED REGULATOR
6	156951021	2	曲柄连杆短销	FEED LINK STUD
7	014680632	2	螺钉 SM4.37-40X6	SET SCREW SOCKET SM4.37-40X6
8	156952021	1	曲柄连杆短销	FEED ROCKER LINK ASSY
9	156954021	1	曲柄长连杆组件	FEED ROCKER ARM LINK ASSY
10	156956021	1	曲柄长连杆销	LINK SHAFT
11	144458001	1	螺钉 SM3.57-40X4.5	SET SCREW SOCKET SM3.57-40X4.5
12	156957120	1	送布曲柄	FEED ROCKER ARM
13	062711412	1	螺钉 SM4.76-32X14	SCREW PAN SM4.76-32X14
14	156958021	1	送布曲柄销	FEED ROCKER ARM SHAFT
15	014680632	1	螺钉 SM4.37-40X6	SET SCREW SOCKET SM4.37-40X6
16	158021122	1	针距调节器连杆组件	F-REGULATOR CONNECT. ROD ASSY
17	15696121	1	偏心销	PIN
18	048060342	1	挡圈 E6	RETAINING RING E6
19	120990001	1	螺钉 SM4.37-40X8	SET SC

H. 切线装置 / Thread trimmer mechanism

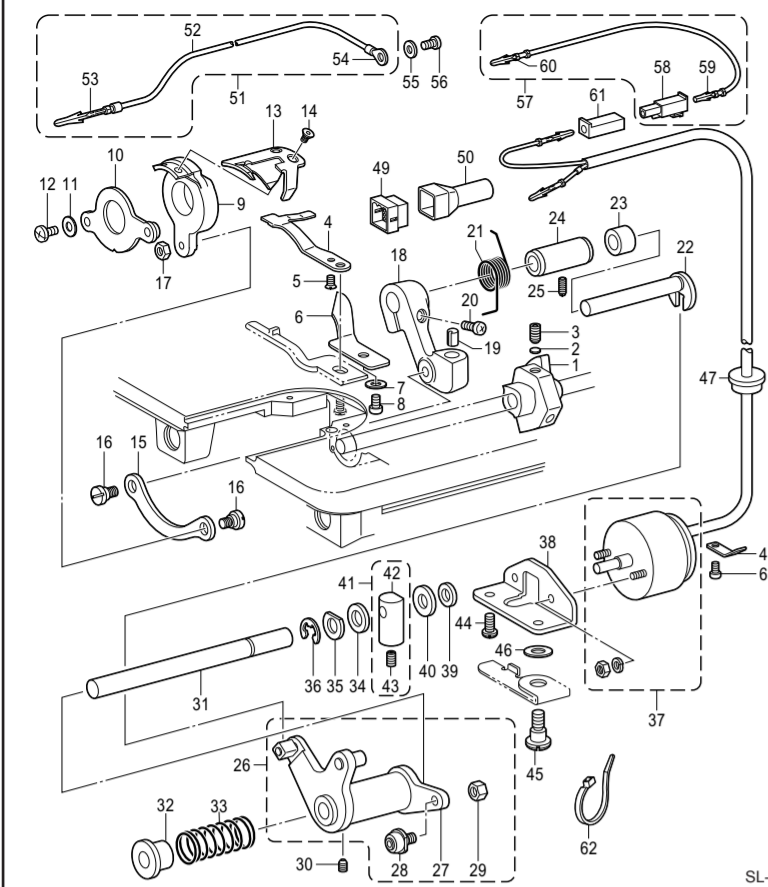

SL-2110-403

参照号	零部件序号	数量	零部件名称	NAME OF PARTS
1	S00337021	1	切线凸轮	THREAD TRIMMER CAM
2	154567020	1	衬垫 5.3	SPACER, 5.3
3	014771032	2	固定螺钉 SM6.35-40X10	SET SCREW SOCKET SM6.35-40X10
4	S02637001	1	固定刀	FIXED KNIFE
5	102843004	1	平头螺钉 SM3.57	SCREW, FLAT SM3.57
6	S02643001	1	分线器	LOWER THREAD FEEDER
7	100645003	1	垫圈	WASHER
8	062680812	1	螺钉 SM4.37-40X8	SCREW PAN SM4.37-40X8
9	154570001	1	刀架	MOVABLE KNIFE HOLDER
10	154571001	1	刀架压板组件	KNIFE HOLDER PRESSER ASSY
11	100645003	2	垫圈	WASHER
12	060681212	2	螺钉 SM4.37-40X12	SCREW BIND SM4.37-40X12
13	S02645001	1	动力	MOVABLE KNIFE
14	148537101	2	螺钉 SM4.37	SCREW, FLAT (W/SOCKET) SM4.37
15	154570023	1	刀架连接杆	THREAD TRIMMER CONNECTING ROD
16	151987022	2	螺钉 SM4.37	SHOULDER SCREW, SM4.37
17	102571003	1	螺母 SM4.37	NUT, SM4.37
18	SA8245001	1	切线杆	THREAD TRIMMER LEVER
19	SA7285001	1	手杆定位	LEVER STOPPER
20	062711412	1	螺钉 SM7.76-32X14	SCREW PAN SM7.76-32X14
21	154579001	1	弹簧	SPRING
22	S02647021	1	切刀驱动曲柄轴	FORKED SHAFT
23	S02648021	1	曲柄套	COLLAR
24	154581021	1	叉轴轴套	FORKED SHAFT BUSH

25	121007001	1	螺钉 SM4.37	SCREW
26	S58962101	1	切线凸轮杆组件	THREAD TRIMMER CAM LEVERUNIT
27	S58963001	1	切线凸轮杆组件	THREAD TRIMMER CAM LEVER ASSY
28	SA2258001	1	轴套	ROLLER SHAFT, C ASSY
29	105234003	1	螺母 SM4.37	NUT SM4.37
30	014770632	1	螺钉 SM6.35-40X6	SET SCREW SOCKET SM6.35-40X6
31	154533221	1	切刀驱动轴	THREAD TRIMMER CAM LEVER SHAFT
32	154584020	1	挡圈	COLLAR
33	154595001	1	切线凸轮复位弹簧	SPRING, EXTENSION
34	154596000	1	减震器	CUSHION
35	110367001	1	垫圈 8	WASHER, PLAIN SPECIAL 8
36	048060342	1	挡圈 E6	RETAINING RING E6
37	S02815009	1	切线电磁铁	THREAD TRIMMER SOLENOID
38	154598021	1	切线电磁铁架	THREAD TRIMMER SOLENOID BASE
39	154599001	1	电磁铁缓冲垫圈	SOLENOID CUSHION
40	S02652021	1	垫圈	WASHER
41	S28386021	1	电磁驱动臂组件	SOLENOID LEVER ASSY
42	S02654021	1	电磁驱动臂	SOLENOID LEVER
43	014680632	1	螺钉 SM4.37-40X6	SET SCREW SOCKET SM4.37-40X6
44	110201001	1	螺钉 SM6.35	SCREW, SM6.35
45	S02655022	1	螺钉 SM6.35	SHOULDER SCREW, SM6.35
46	153559021	1	平垫圈	WASHER, PLAIN
47	146020001	1	电枢衬套	CORD BUSH
48	S02657121	1	油线夹板	CORD HOLDER
49	153969000	1	尼龙接头 12P	NYLON CONNECTOR, 12P
50	S03815001	1	接头套 6	CONNECTOR CAP, 6
51	S02682001	1	地线组件	GROUND WIRE ASSY
52	S02683000	1	地线	GROUND WIRE
53	S04328000	1	接头插针 L	TERMINAL PIN, L, MALE
54	204589001	1	接头插针 4.5X14	TERMINAL, 4.5X14
55	S02745021	1	垫圈	WASHER
56	062680663	1	螺钉 SM4.37-40X6	SCREW PAN SM4.37-40X6
57	S11210000	1	W 线 S 组件	W-CORD ASSY, S
58	S11684000	1	接头 3191-01R1	CONNECTOR, 3191-01R1
59	143548000	1	接头插芯	TERMINAL PIN, FEMALE
60	143549000	1	接头插针	TERMINAL PIN, MALE
61	S11683000	1	接头 3191-01P1	CONNECTOR, 3191-01P1
62	S04159000	1	线夹 1M	BAND 1M
63	062670612	1	螺钉 SM3.57-40X6	SCREW PAN SM3.57-40X6

J. 膝控提升装置 / Knee lifter mechanism

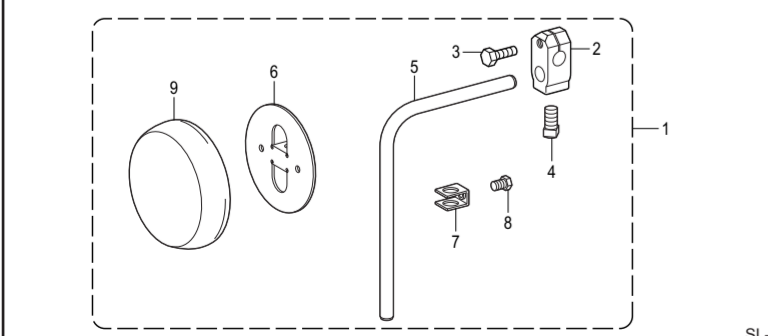

SL-2110-203

参照号	零部件序号	数量	零部件名称	NAME OF PARTS
1	S35821021	1	膝控提升组件	KNEE LIFTER ASSY
2	146039121	1	膝控提升架	KNEE LIFTER BRACKET
3	100463021	1	四方型螺栓 SM7.94	BOLT, SQUARE SM7.94
4	S35820021	1	螺栓 SM5.95X20	BOLT, SM5.95X20
5	104619022	1	膝控提升轴杆	KNEE LIFTER BAR
6	S34756021	1	膝控提升板	KNEE LIFTER PLATE
7	114987021	1	膝控提升板	KNEE LIFTER PLATE STOPPER
8	110087021	1	螺栓 SM5.95-28X8	BOLT, SM5.95-28X8
9	S31885001	1	膝控提升板盖	KNEE LIFTER PLATE COVER

K. 穿线装置 / Threading mechanism

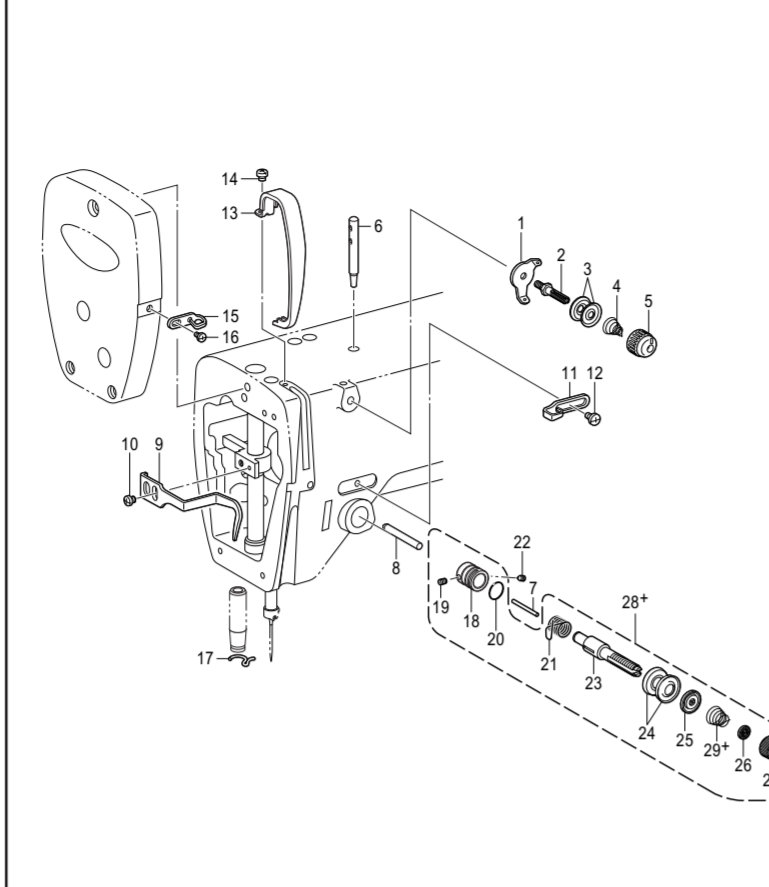

SL-2110-401

参照号	零部件序号	数量	零部件名称	NAME OF PARTS
1	SA2362001	1	小夹线过线器	THREAD GUIDE
2	S45563001	1	夹线螺钉	THREAD GUIDE TENSION STUD
3	144504001	2	小夹线板	THREAD GUIDE DISC
4	SA2358101	1	小夹线弹簧 B	PRE-TENSION SPRING B
5	SA6187001	1	预紧螺母	THREAD TENSION NUT
6	147557101	1	过线针	SPOOL PIN
7	150551020	1	松线轴	TENSION RELEASE PIN
8	SA8178001	1	松线杆	TENSION RELEASE STUD
9	SA8177001	1	线导向	THREAD GUIDE P-BAR BRACKET
10	062880812	1	螺钉 SM4.37-40X8	SCREW PAN SM4.37-40X8
11	145522101	1	衬套线钩 R	ARM THREAD GUIDE, R
12	S19056001	1	螺钉 SM3.57-40X6	SCREW BIND SM3.57-40X6
13	S58910001	1	接线杆罩	THREAD TAKE-UP COVER
14	062880812	1	螺钉 SM4.37-40X8	SCREW PAN SM4.37-40X8
15	S02617001	1	面板线钩	FACE PLATE THREAD GUIDE
16	060670612	1	螺钉 SM3.57-40X6	SCREW BIND SM3.57-40X6
17	100573001	1	针杆线钩	THREAD GUIDE, D
18	SA40938001	1	夹线杆托架	THREAD TENSION BRACKET
19	100402004	1	固定螺钉 SM3.57	SET SCREW, SM3.57
20	114294001	1	O 形密封圈	O-RING

21	S02620301	1	接线弹簧	THREAD TAKE-UP SPRING
22	S55976001	1	固定螺钉 SM5.95	SET SCREW, SM5.95
23	116922001	1	夹线螺钉	TENSION STUD
24	145446021	2	夹线盘	DISC, TENSION
25	159805001	1	夹线压盘	TENSION DISC PRESSER
26	S12441001	1	止动垫圈	WASHER
27	S31032001	1	压线螺母	TENSION NUT
28	S55654221	1	夹线器组件	THREAD TENSION BRACKET ASSY
29	S04632101	1	夹线弹簧	TENSION SPRING
30	S04632101	1	夹线弹簧	THREAD TENSION BRACKET ASSY
31	S25456021	1	垫圈	TENSION SPRING
32	S02681101	1	插销	PLUNGER PIN
33	060400516	1	螺钉 M4X5	SCREW BIND M4X5
34	146288021	1	插销	THREAD WIPER STUD COLLAR
35	025750132	1	平垫圈 S5.56	WASHER, PLAIN S, S5.56
36	SA1207000	1	橡皮垫圈	SPACER RUBBER
37	149097000	1	清音垫	SILENT SHEET

L. 针位检测装置 / Synchronizer

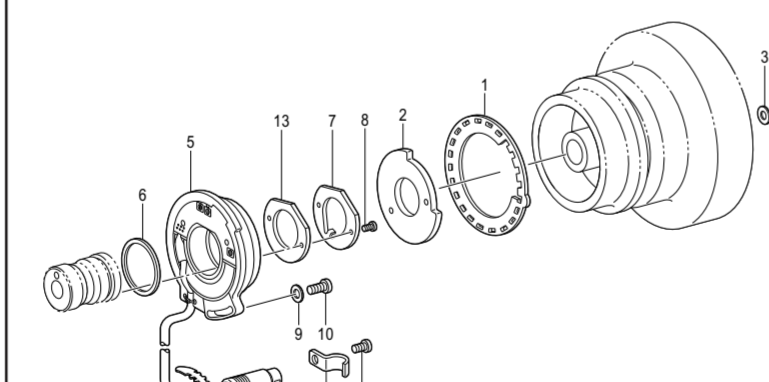

SL-2110-501

参照号	零部件序号	数量	零部件名称	NAME OF PARTS
1	SA8437001	1	速度控制板 24	SPEED COMMAND PLATE, 24
2	SA8438001	1	针上位置板	NEEDLE UPPER POSITIONING PLATE
3	100845003	2	垫圈	WASHER
4	062681612	2	螺钉 SM4.37-40X16	SCREW PAN SM4.37-40X16
5	SA8439001	1	针位检测器 #18-2 X	SYNCHRONIZER #18-2 X
6	SA8440001	1	针位检测器垫片	SYNCHRONIZER PACKING
7	SA8441001	1	针位检测器撑板	SYNCHRONIZER SUPPORT
8	062630712	2	螺钉 SM2.38-56X7	SCREW PAN SM2.38-56X7
9	113431022	1	垫圈	WASHER, PLAIN
10	062711012	1	螺钉 SM4.76-32X10	SCREW PAN SM4.76-32X10
11	140647121	1	电线固定夹	CORD HOLDER
12	062670612	1	螺钉 SM3.57-40X6	SCREW PAN SM3.57-40X6
13	SA8442001	1	针位检测器撑板垫片	SYNCHRONIZER SUPPORT PACKING

M. 扫线装置 / Thread wiper mechanism

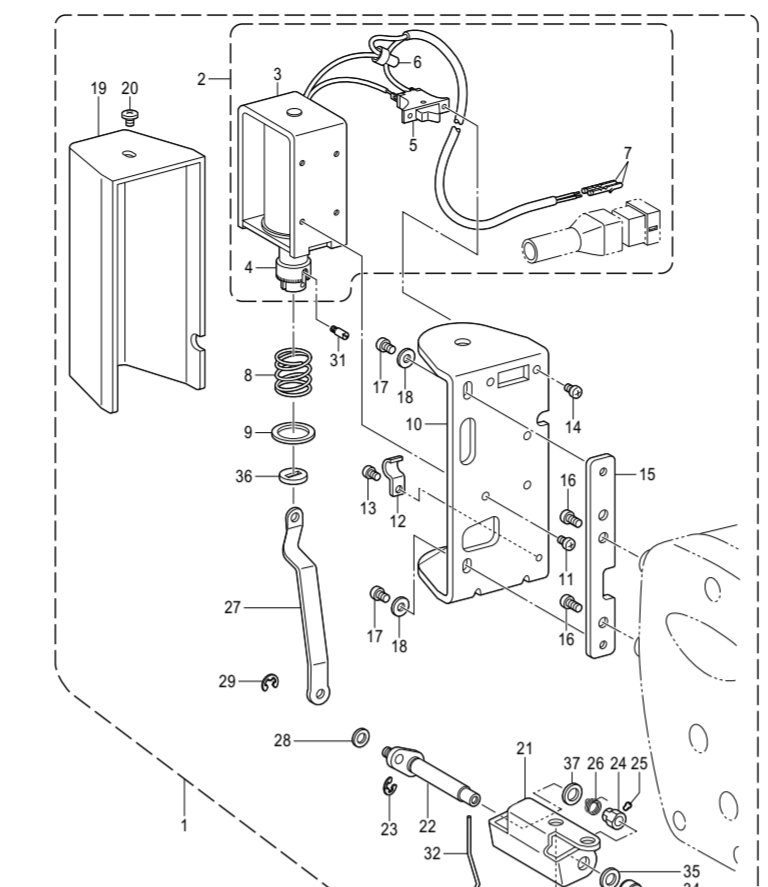

SL-2110-405

参照号	零部件序号	数量	零部件名称	NAME OF PARTS
1	SA8491001	1	<用于-40J>	<For-40J>
2	S41202151	1	扫线装置组合件	THREAD WIPER DEVICE ASSY
3	S41203051	1	扫线电磁铁组件	THREAD WIPER SOLENOID ASSY
4	SA1204050	1	扫线电磁铁	THREAD WIPER SOLENOID
5	S02664051	1	弹性垫圈	PLUNGER RUBBER
6	S02665051	1	扫线开关	THREAD WIPER SWITCH
7	S02665051	1	电磁接头	TERMINAL CONNECTOR
8	143549050	2	接头插针	TERMINAL PIN, MALE
9	S41206001	1	扫线弹簧	THREAD WIPER SPRING
10	S41205001	1	平垫圈	WASHER, PLAIN
11	S25449321	1	电磁铁安装板	SOLENOID SETTING PLATE
12	062300616	3	螺钉 M3X6	SCREW PAN M3X6
13	1406947121	1	垫圈	WASHER, PLAIN
14	062300616	1	螺钉 M3X6	SCREW PAN M3X6
15	062300616	2	螺钉 M3X6	SCREW PAN M3X6
16	S33609121	1	电磁铁安装架	SOLENOID SETTING BASE
17	062681012	2	螺钉 SM4.37-40X10	SCREW PAN SM4.37-40X10
18	062400616	2	螺钉 M4X6	SCREW PAN M4X6
19	026040236	2	平垫圈 M4	WASHER, PLAIN M4
20	S33610121	1	O 形圈	SOLENOID COVER

21	060400616	1	螺钉 M4X6	SCREW BIND M4X6
22	S02672022	1	扫线轴架	THREAD WIPER SUPPORT
23	S25452021	1	扫线轴轴架组件	THREAD WIPER CRANK ASSY
24	048040342	1	挡圈 E4	RETAINING RING E4
25	S25454021	1	螺帽螺母	SET SCREW, SM4.37
26	S25279101	1	螺钉 M3.5-5	SET SCREW (CP) M3.5-5
27	S02676001	1	扫线弹簧	WIPER SPRING
28	SA8189001	1	扫线连杆	THREAD WIPER LINK
29	110735022	1	垫圈	WASHER
30	048030342	1	挡圈 E3	RETAINING RING E3
31	S09890001	2	螺栓 SM4.37-40X8	BOLT, SOCKET SM4.37-40X8
32	S25456021	1	垫圈	WASHER, VFS 6.5
33	S02681101	1	插销	PLUNGER PIN
34	060400516	1	螺钉 M4X5	SCREW BIND M4X5
35	146288021	1	插销	THREAD WIPER STUD COLLAR
36	025750132	1	平垫圈 S5.56	WASHER, PLAIN S, S5.56
37	SA1207000	1	橡皮垫圈	SPACER RUBBER
38	149097000	1	清音垫	SILENT SHEET

N. 倒缝装置 / Quick reverse mechanism

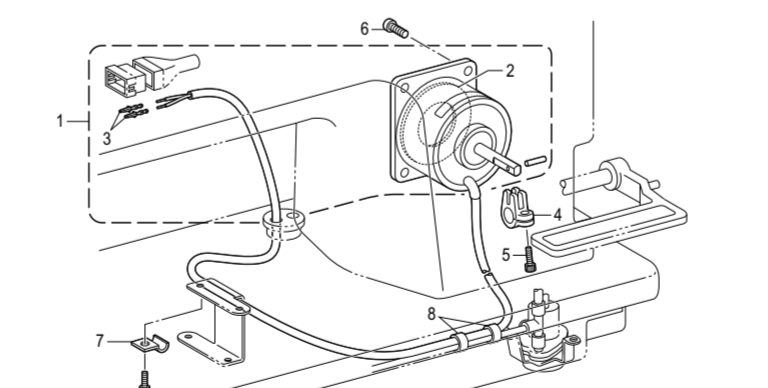

SL-2110-205

参照号	零部件序号	数量	零部件名称	NAME OF PARTS
1	S02597019	1	倒缝电磁铁组件	QUICK REVERSE SOLENOID ASSY
2	157981000	1	衬垫	CUSHION
3	143549000	2	接头插针	TERMINAL PIN, MALE
4	S02600000	1	电磁铁接头	SOLENOID LEVER
5	S07959001	1	螺钉 SM4.76-32X14	BOLT, SOCKET SM4.76-32X14
6	062711012	4	螺钉 SM4.76-32X10	SCREW PAN SM4.76-32X10
7	140647121	1	电线固定夹	CORD HOLDER
8	146253000	2	固定圈	TUBE

74	SA8256011	1	机针组 (2 枚) #11	NEEDLE 2PIECE ASSY #11
74	SA8256014	1	机针组 (2 枚) #14	NEEDLE 2PIECE ASSY #14
74	SA8256022	1	机针组 (2 枚) #22	NEEDLE 2PIECE ASSY #22
74	SA8257011	1	机针组 (2 枚) #11	NEEDLE 2PIECE ASSY #11
74	SA8257014	1	机针组 (2 枚) #14	NEEDLE 2PIECE ASSY #14

75	146290021	1	<用于-10J>	<For-10J>
76	117132001	1	楔芯	<For-10J>
76	117132001	1	<用于-10J>	<For-10J>
76	117132001	1	楔芯	<For-10J>

77	S36122205	1	<用于中国>	<For China only>
77	S36122205	1	V 形皮带 M 白色 40-49	V-BELT M WHITE, 40-49

P. 附件 / Accessories

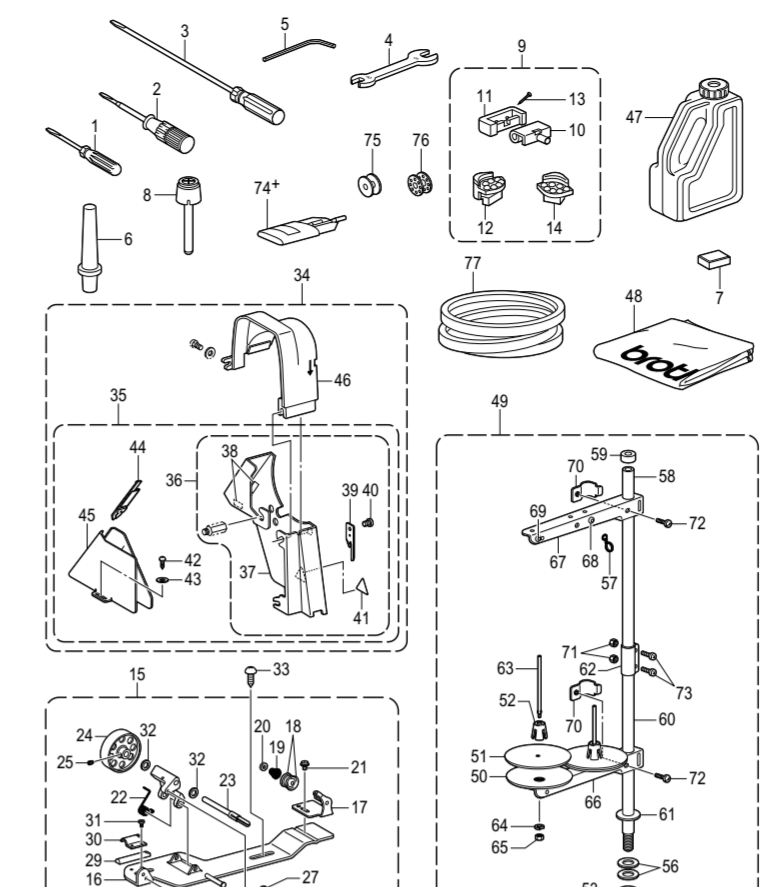

SL-2110-910

参照号	零部件序号	数量	零部件名称	NAME OF PARTS
1	142443021	1	小起子 1.9X52	SCREW-DRIVER, 1.9X52
2	118837021	1	起子 3.4X70	SCREW-DRIVER, 3.4X70
3	101572101	1	起子 5.5X190	SCREW-DRIVER, 5.5X190
4	100887021	1	双头扳手 8X9	WRENCH, 8X9
5	142002001	1	内六角扳手 2	HEXAGONAL WRENCH, 2
6	S06055029	1	机头螺母 S	HEAD REST, S
7	112525020	1	磁块	MAGNET
8	S09634020	1	膝控提升顶杆	KNEE LIFTER COMPLYING BAR
9	S80028221	1	橡胶衬套	RUBBER HINGE ASSY
10	143882021	2	机头衬套	HEAD HINGE
11	143910029	2	橡胶衬套	RUBBER CUSHION
12	S53567201			