

S-7000DD

零件手册
PARTS BOOK

电脑直接驱动自动切线平缝机

SINGLE NEEDLE DIRECT DRIVE STRAIGHT LOCK STITCHER
WITH THREAD TRIMMER

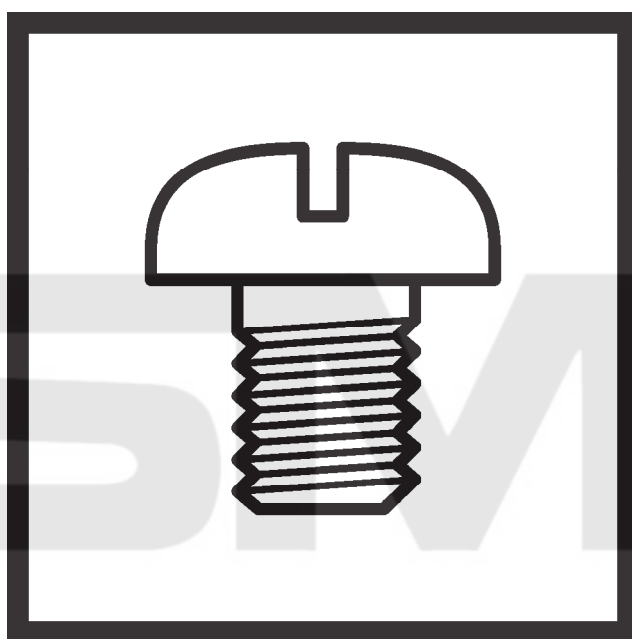

brother[®]

最新的零部件情报请参考(Parts Navigation).
The latest parts information, refer to the Parts Navigation.

<http://partsbook.brother.co.jp/partsnavi/chn/>
<http://partsbook.brother.co.jp/partsnavi/eng/>

型号牌的读解法

•S-7000DD-■0■•

3. 用于轻薄布料到中厚布料

3A. 用于中厚布料

5. 用于厚布料

3. 倒缝

4. 倒缝+扫线

Description of model plate

•S-7000DD-□□0□□•

3. Light-weight and Medium-weight materials

3A. Medium-weight materials

5. Heavy-weight materials

3. Quick Reverse

4. Quick Reverse + Thread Wiper

零件手册的使用说明

1. 本手册是根据截止至2013年5月的资料为基准而编制的。
2. 零部件设计若有变动，恕不另行通知。
3. 以组件为单位供应的零部件是用虚线框出。
4. 零件图册中数字(REF.NO)右上角带有“+”号的零件属多规格零件，详细请见零件清单。

目 录

A. 机体部分	1
B. 针杆和挑线杆装置	3
C. 压脚装置	5
D. 送料装置	7
E. 膝控提升装置	11
F. 倒缝装置	13
G. 旋梭装置	15
H. 供油润滑装置	17
J. 穿线装置	19
K. 绕线装置	21
L. 切线装置	23
M. 松线装置	25
N. 扫线装置 (-40□零部件或选购件)	27
P1. 控制箱	29
P2. 控制箱	31
Q. 倒缝开关装置	33
R. 电气部品	35
S. 马达装置和操作盘	37
Z. 附件	39
Wa. 警告标签	41
Ga. 工模具一览表	43
索引	44

Notes for using this parts book

1. This book was prepared based on information available in May 2013.
2. Parts are subject to changes in design without prior notice.
3. Parts supplied as complete assemblies are circled by a dotted line.
4. The part which has the symbol "+" on its number (REF.NO) in the figure differs depending on the specification. For details, refer to the parts list.

CONTENTS

A. Machine body	1
B. Needle bar and thread take-up mechanism	3
C. Presser foot mechanism	5
D. Feed mechanism	7
E. Knee lifter mechanism	11
F. Quick reverse mechanism	13
G. Rotary hook mechanism	15
H. Lubrication	17
J. Threading mechanism	19
K. Bobbin winder mechanism	21
L. Thread trimmer mechanism	23
M. Tension release mechanism	25
N. Thread wiper mechanism (-40[] or option parts)	27
P1. Control box	29
P2. Control box	31
Q. Quick reverse switch mechanism	33
R. Power supply equipment	35
S. Motor mechanism and operation panel	37
Z. Accessories	39
Wa. Warning labels	41
Ga. Gauge parts list	43
Index	44

A. 机体部分 / Machine body

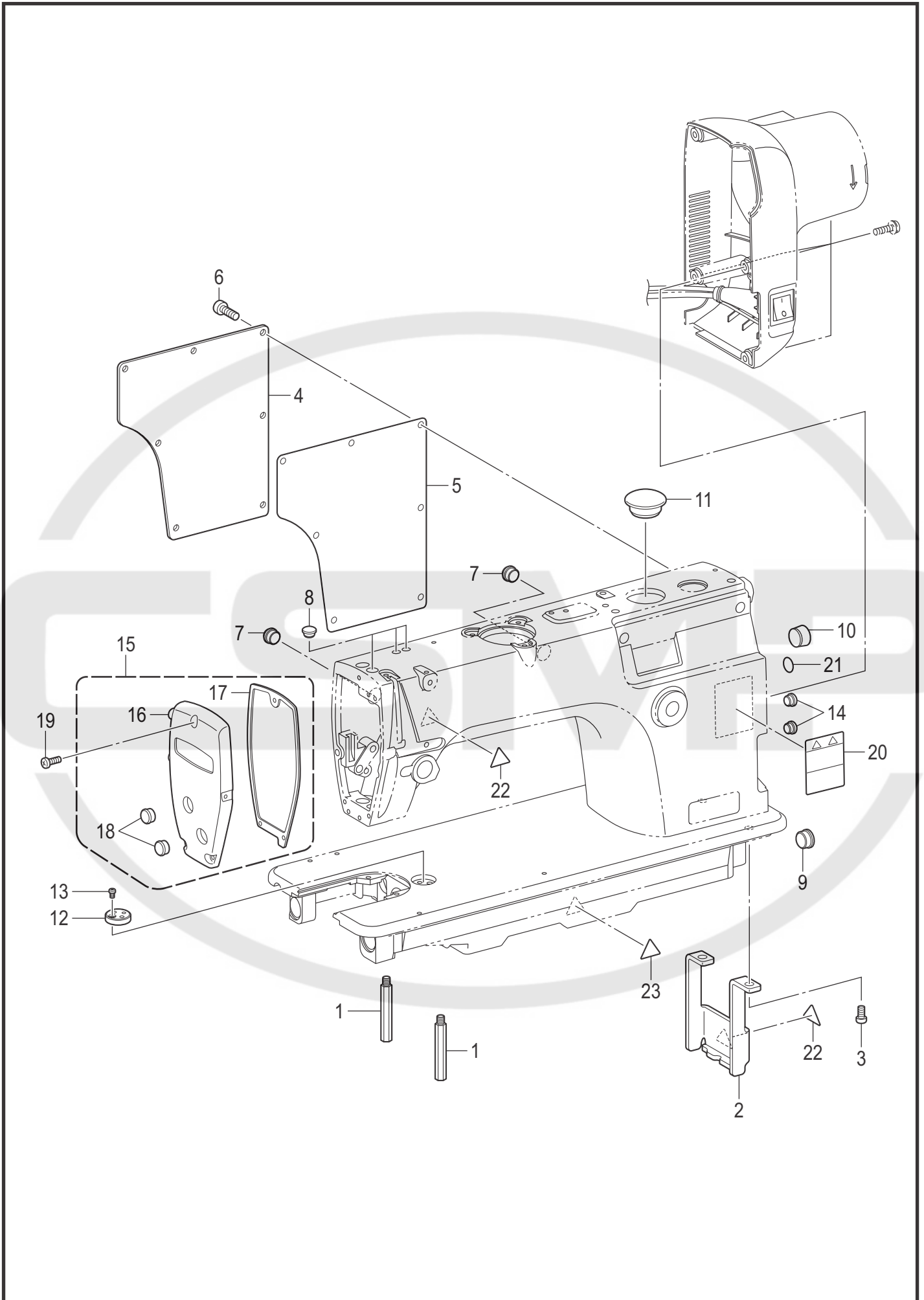

S-7000DD-050

A. 机体部分 / Machine body

参照号	零部件序号	数量	零部件名称	NAME OF PARTS	RM
1	SB3440001	2	脚柱L	STAND L	
2	SB3441001	1	脚柱R	STAND R	
3	062061016	2	螺钉 M6X10	SCREW PAN M6X10	
4	SB3433001	1	后侧盖	SIDE PLATE	
5	SB3434001	1	后侧板衬垫	REAR COVER PACKING	
6	062501216	7	螺钉 M5X12	SCREW PAN M5X12	
7	104449001	2	橡皮塞 15.5	RUBBER CAP, 15.5	
8	104450101	3	橡皮塞 8	RUBBER CAP, 8	
9	108520001	1	橡皮塞 19.8	RUBBER CAP, 19.8	
10	SB3986001	1	橡皮塞 17.9	RUBBER CAP 17.9	
11	SB3442001	1	橡皮塞 37.8	RUBBER CAP 37.8	
12	SB3850001	1	定位板	RULER PLATE	
13	062400616	1	螺钉 M4X6	SCREW PAN M4X6	
14	104450101	2	橡皮塞 8	RUBBER CAP, 8	
15	SB3435001	1	面板组件	FACE PLATE ASSY	
16	SB3436001	1	面板	FACE PLATE	
17	SB3437001	1	面板垫片	FACE PLATE PACKING	
18	104449001	2	橡皮塞 15.5	RUBBER CAP, 15.5	
19	062671212	3	螺钉 SM3.57-40X12	SCREW PAN SM3.57-40X12	
20	SA9826001	1	操作注意标签	LABEL CAUTION	
21	S37060021	1	接地标记	LABEL, GROUNDING	
22	SA9957001	2	警告标记	INJURY MARK	
23	SA9957002	1	警告标记	INJURY MARK	

B. 针杆和挑线杆装置 / Needle bar and thread take-up mechanism

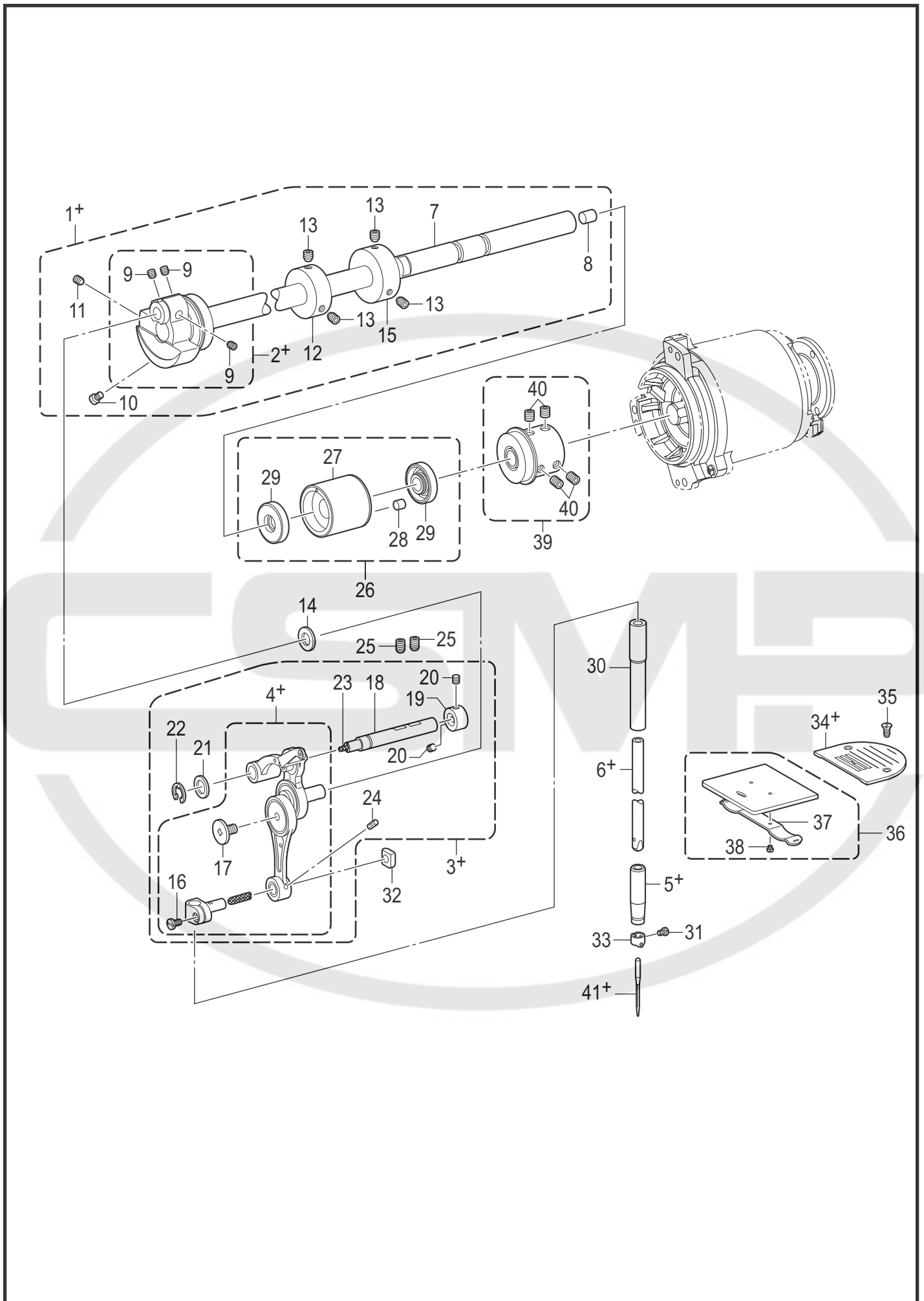

B. 针杆和挑线杆装置 / Needle bar and thread take-up mechanism

参照号	零部件序号	数量	零部件名称	NAME OF PARTS	RM
1+	SB3445001	1	<用于-□03. -□03A> 上轴组件	<For -□03, -□03A> UPPER SHAFT ASSY	
2+	SB3447001	1	挑线杆曲柄组件	THREAD TAKE-UP CRANK ASSY	
3+	SB3770001	1	针杆连杆总组件	NEEDLE BAR CONNECTING ROD UNIT	
4+	SB3771001	1	针杆连杆组件	NEEDLE BAR CONNECTING ROD ASSY	
5+	SB3783001	1	针杆轴套 D	NEEDLE BAR BUSH D	
6+	SB3912001	1	针杆 DB <用于DB机针>	NEEDLE BAR DB <FOR DB NEEDLE>	
6+	SB4084001	1	针杆 DP <用于DP机针>	NEEDLE BAR DP <FOR DP NEEDLE>	
			<用于-□05>	<For -□05>	
1+	SB4074001	1	上轴组件	UPPER SHAFT ASSY	
2+	SB4039001	1	挑线杆曲柄组件	THREAD TAKE-UP CRANK ASSY	
3+	SB3777001	1	针杆连杆总组件	NEEDLE BAR CONNECTING ROD UNIT	
4+	SB3778001	1	针杆连杆组件	NEEDLE BAR CONNECTING ROD ASSY	
5+	SB3784001	1	针杆轴套 D	NEEDLE BAR BUSH D	
6+	SB3913001	1	针杆	NEEDLE BAR	
7	SB3446201	1	上轴	UPPER SHAFT	
8	SB2407001	1	橡皮塞 6.4	RUBBER CAP 6.4	
9	014770632	3	螺钉 SM6.35-40X6	SET SCREW SOCKET SM6.35-40X6	
10	SB3769001	1	螺钉 SM7.14-28	SCREW SM7.14-28	
11	014771032	1	固定螺钉 SM6.35-40X10	SET SCREW SOCKET SM6.35-40X10	
12	SB3449001	1	绕线驱动轮	BOBBIN WINDER DRIVING WHEEL	
13	014771032	4	固定螺钉 SM6.35-40X10	SET SCREW SOCKET SM6.35-40X10	
14	SA8145001	1	垫圈	WASHER	
15	SB4492001	1	上轴轮	UPPER SHAFT WHEEL	
16	140004001	1	螺钉 SM3.57-40X7	SCREW, SM3.57-40X7	
17	SA2422001	1	螺钉 SM3.57-40X6L	SCREW, SM3.57L	
18	SB3775001	1	挑线杆支撑轴	THREAD TAKE-UP SUPPORT SHAFT	
19	SB3776001	1	紧圈	SET SCREW COLLAR	
20	012400536	2	螺钉 M4X5	SET SCREW SOCKET (FT) M4X5	
21	SA2161001	1	垫圈	WASHER	
22	048060342	1	挡圈 E6	RETAINING RING E6	
23	S32958000	1	油线	WICK	
24	SA8436001	1	油毡	FELT	
25	012060636	2	螺钉 M6X6	SET SCREW SOCKET (FT) M6X6	
26	SB3851201	1	上轴轴套M组件	UPPER SHAFT BUSH M ASSY	
27	SB3455201	1	上轴轴套M	UPPER SHAFT BUSH M	
28	142274101	1	橡皮塞 4.2	RUBBER CAP, 4.2	
29	101487000	2	油封	OIL SEAL	
30	SB3782001	1	针杆轴套 U	NEEDLE BAR BUSH U	
31	140553102	1	固定螺钉 SM3.18	SET SCREW, SM3.18	
32	SB3458001	1	针杆导向滑块	NEEDLE BAR GUIDE SLIDE BLOCK	
33	151594001	1	针杆过线环	NEEDL BAR THREAD GUIDE	
			<用于-□03>	<For -□03>	
34+	111859301	1	针板 E18	NEEDLE PLATE E18	
			<用于-□03欧洲. -□03A>	<For -□03 Europe, -□03A>	
34+	145971101	1	针板 B18	NEEDLE PLATE B18	
			<用于-□05>	<For -□05>	
34+	150792101	1	针板 H26	NEEDLE PLATE H26	
35	SB4190001	2	螺钉 SM4.37-40X8	SCREW FLAT SM4.37-40X8	
36	180018151	1	推板组件	SLIDE PLATE ASSY	
37	114561001	1	推板簧	SPRING, PLATE	
38	SA9523001	2	螺钉 SM2.38	SCREW SM2.38	
39	SB3977001	1	接头组件	JOINT ASSY	
40	S23651001	4	固定螺钉 M6X6	SET SCREW SOCKET (FT) M6X6	
			<用于-□03. -□03A>	<For -□03, -□03A>	
41+		1	机针DBX1...(#11)	NEEDLE DBX1...(#11)	
41+		1	机针DBX1...(#14)	NEEDLE DBX1...(#14)	
41+		1	机针DPX5...(#11)	NEEDLE DPX5...(#11)	
			<用于-□05>	<For -□05>	
41+		1	机针DBX1...(#22)	NEEDLE DBX1...(#22)	
41+		1	机针DPX5...(#22)	NEEDLE DPX5...(#22)	

C. 压脚装置 / Presser foot mechanism

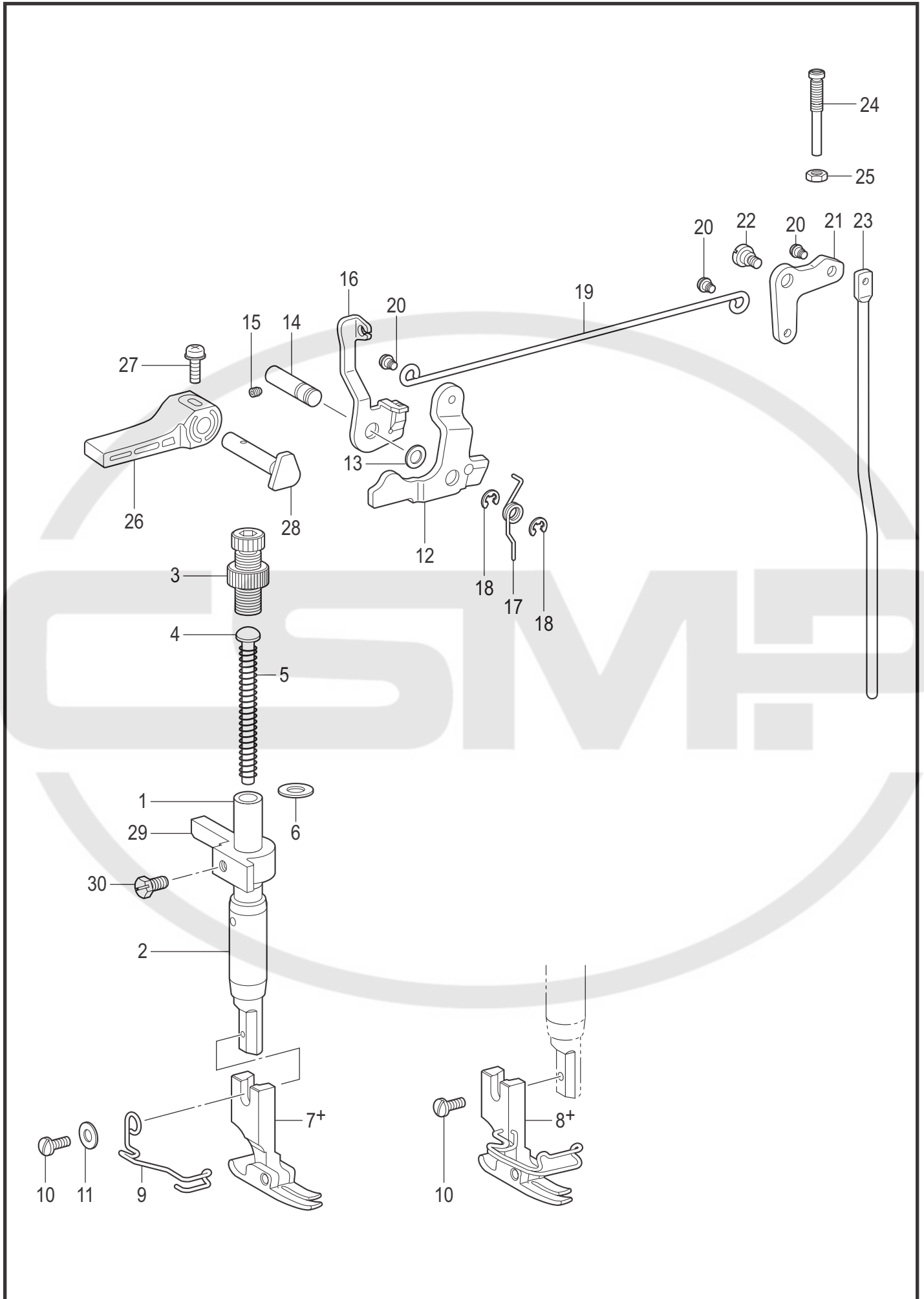

C. 压脚装置 / Presser foot mechanism

参照号	零部件序号	数量	零部件名称	NAME OF PARTS	RM
1	111466121	1	压紧杆	PRESSER BAR	
2	SB3785001	1	压紧杆轴套	PRESSER BAR BUSH	
3	SB2267002	1	调压螺拴组件	PRESSER ADJUSTING SCREW ASSY	
4	SB3786001	1	弹簧导杆	SPRING GUIDE	
5	141728001	1	压杆弹簧	PRESSER BAR SPRING	
6	140407021	1	垫圈	WASHER	
			<使用螺钉固定护指器>	<Finger guard screwed type>	
			<用于-□03>	<For -□03>	
7+	153037221	1	压脚组件	PRESSER FOOT ASSY	
			<用于-□05>	<For -□05>	
7+	150789121	1	压脚组件	PRESSER FOOT ASSY	
9	150384101	1	护指器	FINGER GUARD	
11	025350132	1	平垫圈 S3.5	WASHER PLAIN S 3.5	
			<护指器一体式>	<Finger guard integral type>	
			<用于-□03, -□03A>	<For -□03, -□03A>	
8+	S36902001	1	压脚组件	PRESSER FOOT ASSY W/F-G	
			<用于-□05>	<For -□05>	
8+	S36903001	1	压脚组件	PRESSER FOOT ASSY W/F-G	
10	S13385001	1	螺钉 SM3.57-40X10	SCREW, SM3.57-40X10	
12	145580001	1	膝控提升左杠杆	LIFTER LEVER P-BAR	
13	109763022	1	垫圈	WASHER	
14	SA8152001	1	膝控提升杆短轴	PRESSER BAR LIFTER SHAFT	
15	012500536	1	螺钉 M5X5	SET SCREW SOCKET (FT) M5X5	
16	S02546402	1	松线架	TENSION RELEASE PLATE	
17	S46736001	1	弹簧	W-CLAMP LIFTER LEVER SPRING	
18	048040342	2	挡圈 E4	RETAINING RING E4	
19	SB3463001	1	膝控连杆	KNEE LIFTER CONNECTING ROD	
20	SB3878001	3	轴位螺钉 SM4.76	SHOULDER SCREW SOCKET SM4.76	
21	SB3461001	1	膝控提升手杆	KNEE LIFTER LEVER	
22	145480121	1	轴位螺钉 SM6.35	SHOULDER SCREW, SM6.35	
23	SB3460001	1	膝控提升杆	KNEE LIFTER BAR	
24	SB4016001	1	调整螺钉 6	ADJUSTING SCREW 6	
25	021060306	1	六角螺母 M6	NUT 3 M6	
26	S31006002	1	抬压脚扳手	LIFTING LEVER	
27	S39051001	1	螺钉(带垫圈)M3.5X12	SCREW, PAN (S/P W) M3.5X12	
28	S31952021	1	压紧杆扳手曲柄	PRESSER BAR LIFTER CRANK	
29	SB4285001	1	压紧杆导架	PRESSER BAR GUIDE BRACKET	
30	142403001	1	螺钉 SM5.95-28X10	BOLT, (CP) SM5.95-28X10	

D. 送料装置 / Feed mechanism

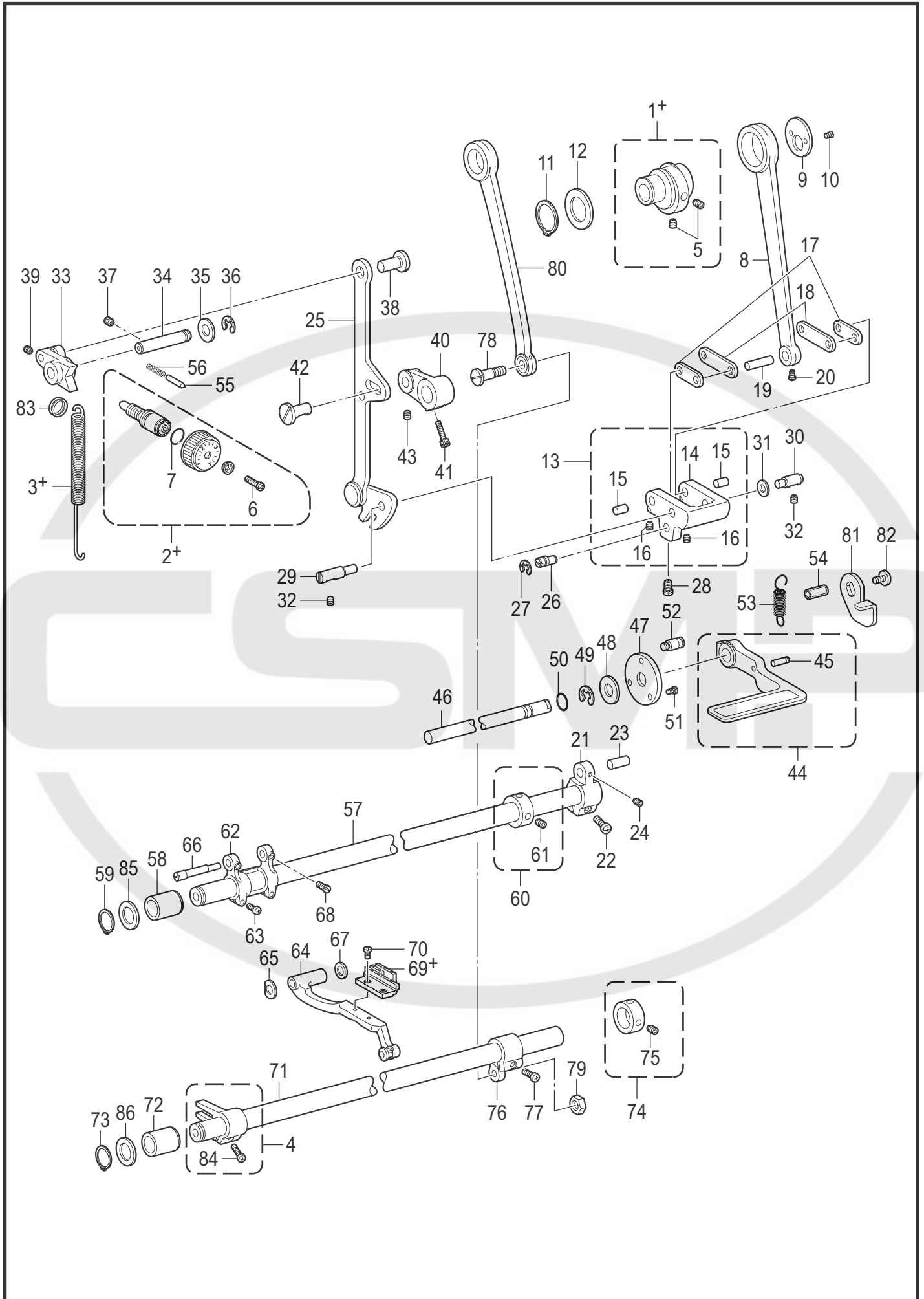

D. 送料装置 / Feed mechanism

参照号	零部件序号	数量	零部件名称	NAME OF PARTS	RM
			<用于-□03>	<For -□03>	
1+	SB3465001	1	偏心轮带螺钉 3	ECCENTRIC WHEEL W/S 3	
2+	SB3472001	1	针距标盘组件 3	STITCH LENGTH DIAL ASSY 3	
3+	S02558201	1	拉簧	EXTENSION SPRING	
			<用于-□03A, -□05>	<For -□03A, -□05>	
1+	SB3467001	1	偏心轮带螺钉 5	ECCENTRIC WHEEL W/S 5	
2+	SB3475001	1	针距标盘组件 5	STITCH LENGTH DIAL ASSY 5	
3+	S03818101	1	拉簧H	EXTENSION SPRING, H	
4	180322021	1	抬压叉组件	FEED LIFTING ARM ASSY	
5	014771032	2	固定螺钉 SM6.35-40X10	SET SCREW SOCKET SM6.35-40X10	
6	SA4494001	1	螺钉 SM4.76	SCREW SM4.76	
7	108549001	1	O形圈	O RING	
8	S02554021	1	送布连杆	LEVEL FEED CONNECTING ROD	
9	156948021	1	送布连杆挡圈	HOLDER	
10	108960002	2	螺钉 SM3.57	SCREW, FLAT SM3.57	
11	SB3469001	1	轴用挡圈 C21	RETAINING RING EXTERNAL C21	
12	SB2314001	1	垫圈 21.5X31.5	WASHER 21.5X31.5	
13	SB3787001	1	切换器组件	LEVEL FEED REGULATOR ASSY	
14	SB3788001	1	切换器	LEVEL FEED REGULATOR	
15	156951021	2	曲柄连杆短销	FEED LINK STUD	
16	014680632	2	螺钉 SM4.37-40X6	SET SCREW SOCKET SM4.37-40X6	
17	156952021	1	曲柄短连杆组件	FEED ROCKER LINK ASSY	
18	156955021	2	曲柄长连杆	FEED ROCKER ARM LINK	
19	156956021	1	曲柄长连杆销	LINK SHAFT	
20	144458001	1	螺钉 SM3.57-40X4.5	SET SCREW SM3.57-40X4.5	
21	156957120	1	送布曲柄	FEED ROCKER ARM	
22	062711412	1	螺钉 SM4.76-32X14	SCREW PAN SM4.76-32X14	
23	156958021	1	送布曲柄销	FEED ROCK ARM SHAFT	
24	014680632	1	螺钉 SM4.37-40X6	SET SCREW SOCKET SM4.37-40X6	
25	158021122	1	针距调节器连杆组件	F-REGULATOR CONNECT. ROD ASSY	
26	156966121	1	偏心销	PIN	
27	048060342	1	挡圈 E6	RETAINING RING E6	
28	120990001	1	螺钉 SM4.37-40X8	SET SCREW, (CP) SM4.37-40X8	
29	SB3789001	1	切换器轴 L	FEED REGULATOR SHAFT L	
30	SB3790001	1	切换器轴	FEED REGULATOR SHAFT	
31	118735002	1	垫圈	WASHER	
32	012060636	2	螺钉 M6X6	SET SCREW SOCKET (FT) M6X6	
33	156969121	1	针距座	FEED REGULATOR	
34	SB3791001	1	送布调节器轴	FEED REGULATOR SHAFT	
35	S02556021	1	垫圈	WASHER	
36	048070342	1	挡圈 E7	RETAINING RING E7	
37	012060636	1	螺钉 M6X6	SET SCREW SOCKET (FT) M6X6	
38	SB3792001	1	连杆轴 12.5	STUD 12.5	
39	S47264001	1	固定螺钉 SM4.37-40X4	SET SCREW, SOCKET (CP) SM4.37	
40	S02557120	1	倒缝操纵杆曲柄	LEVER	
41	S07959001	1	螺钉 SM4.76-32X14	BOLT, SOCKET SM4.76-32X14	
42	SB3792001	1	连杆轴 12.5	STUD 12.5	
43	S47264001	1	固定螺钉 SM4.37-40X4	SET SCREW, SOCKET (CP) SM4.37	
44	SA8186002	1	倒缝扳手组件	REVERSE STITCHING LEVER ASSY	
45	S02561021	1	拉簧销	SPRING HOOK PIN	
46	SB3793001	1	倒缝扳手轴	SHAFT R-LEVER	
47	147504221	1	挡圈	SPACER	
48	025100132	1	平垫圈 S10	WASHER PLAIN S 10	
49	048080342	1	挡圈 E8	RETAINING RING E8	
50	S33680001	1	O型密封圈	O RING	
51	062670712	3	螺钉 SM3.57-40X7	SCREW PAN SM3.57-40X7	
52	S02562021	1	拉簧钉	SPRING HOOK	
53	S02563001	1	复位簧	SPRING, EXTENSION	
54	153132020	1	尼龙管 L=13.5	NYLON TUBE L=13.5	
55	145502021	1	定位销	POSITIONING PIN	
56	100328001	1	止动销弹簧	NOTCH SPRING	

D. 送料装置 / Feed mechanism

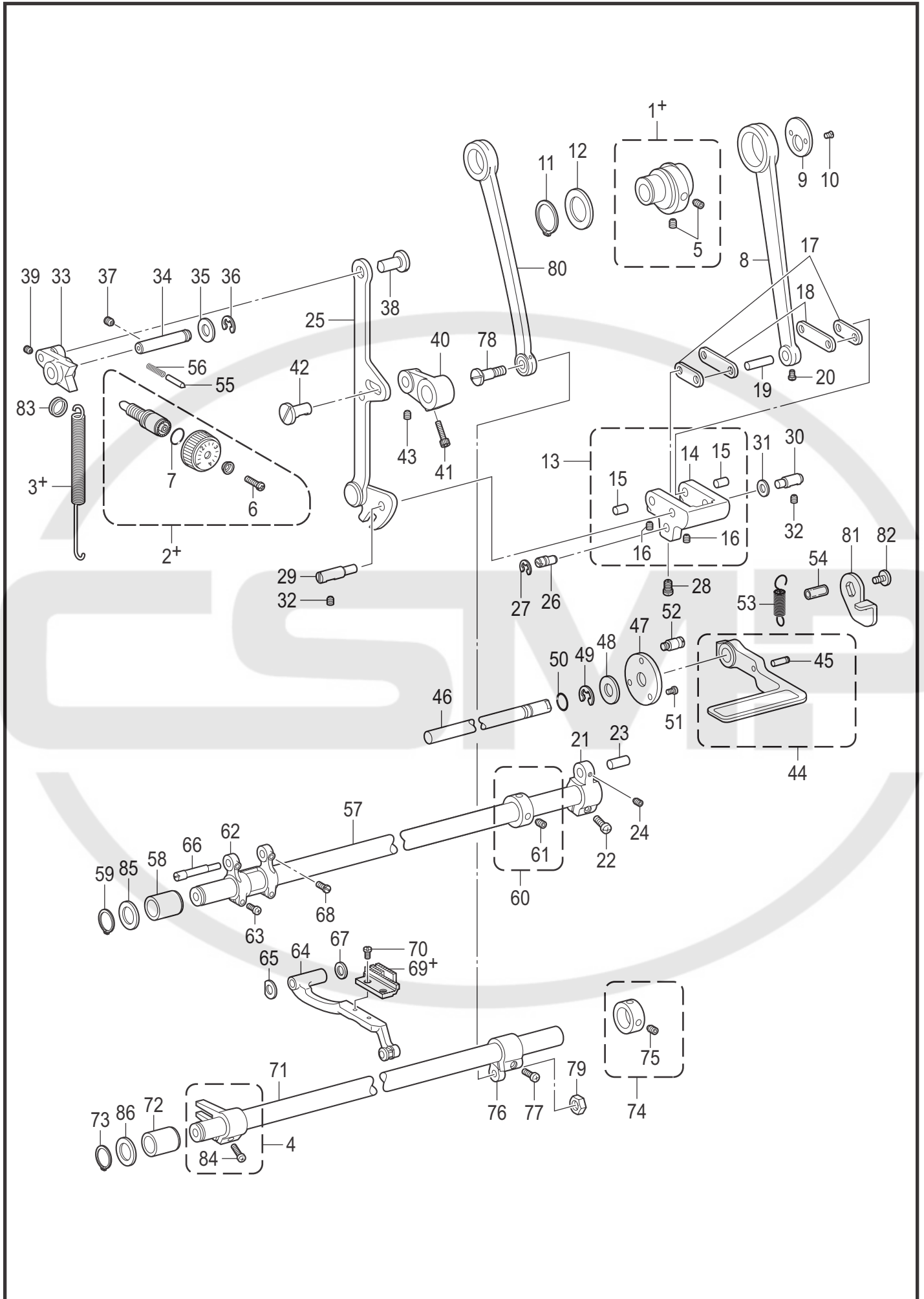

D. 送料装置 / Feed mechanism

参照号	零部件序号	数量	零部件名称	NAME OF PARTS	RM
57	SB3477101	1	水平送布轴	FEED ROCKER SHAFT	
58	S31014020	1	轴套 19.3	BUSH 19.3	
59	048150142	1	轴用挡圈 C15	RETAINING RING EXTERNAL C15	
60	SB3870001	1	紧圈组件	SET SCREW COLLAR ASSY	
61	014770632	2	螺钉 SM6.35-40X6	SET SCREW SOCKET SM6.35-40X6	
62	156244020	1	牙架曲柄	FEED ROCKER BRACKET ARM	
63	062681212	2	螺钉 SM4.37-40X12	SCREW PAN SM4.37-40X12	
64	SB3794001	1	送布台组件	FEED BAR ASSY	
65	S02573020	1	垫圈	WASHER	
66	SB3464001	1	牙架销	FEED BAR STUD	
67	158722021	1	垫圈 4.2	WASHER PLAIN 4.2	
68	120990001	2	螺钉 SM4.37-40X8	SET SCREW, (CP) SM4.37-40X8	
69+	111860121	1	<用于-□03> 送布牙	<For -□03> FEED DOG	
69+	S02742001	1	<用于-□03欧洲, -□03A> 送布牙	<For -□03 Europe, -□03A> FEED DOG	
69+	150793021	1	<用于-□05> 送布牙	<For -□05> FEED DOG	
70	100080004	2	螺钉 SM3.18-44X6.5	SCREW, SM3.18-44X6.5	
71	SB3478101	1	抬牙轴	FEED LIFTING ROCKER SHAFT	
72	S31014020	1	轴套 19.3	BUSH 19.3	
73	048150142	1	轴用挡圈 C15	RETAINING RING EXTERNAL C15	
74	SB3870001	1	紧圈组件	SET SCREW COLLAR ASSY	
75	014770632	2	螺钉 SM6.35-40X6	SET SCREW SOCKET SM6.35-40X6	
76	S02575020	1	抬牙曲柄	F-LIFTING ROCK SHAFT CRANK	
77	062711212	1	螺钉 SM4.76-32X12	SCREW PAN SM4.76-32X12	
78	147509021	1	轴位螺钉 SM7.14	SHOULDER SCREW SM7.14	
79	104689002	1	螺母 SM7.14	NUT 7.14	
80	118758021	1	抬牙连杆	CONNECTING ROD, V-FEEDING	
81	S02578121	1	倒缝操纵杆限位板	REVERSE STITCHING LEVER PLATE	
82	100511123	1	螺钉 SM4.76	SCREW SM4.76	
83	S04228001	1	针距座拉簧环	SPRING HOOK	
84	062681412	1	螺钉 SM4.37-40X14	SCREW PAN SM4.37-40X14	
85	156243021	1	送布轴轴套垫圈	THRUST RING	
86	156243021	1	送布轴轴套垫圈	THRUST RING	

E. 膝控提升装置 / Knee lifter mechanism

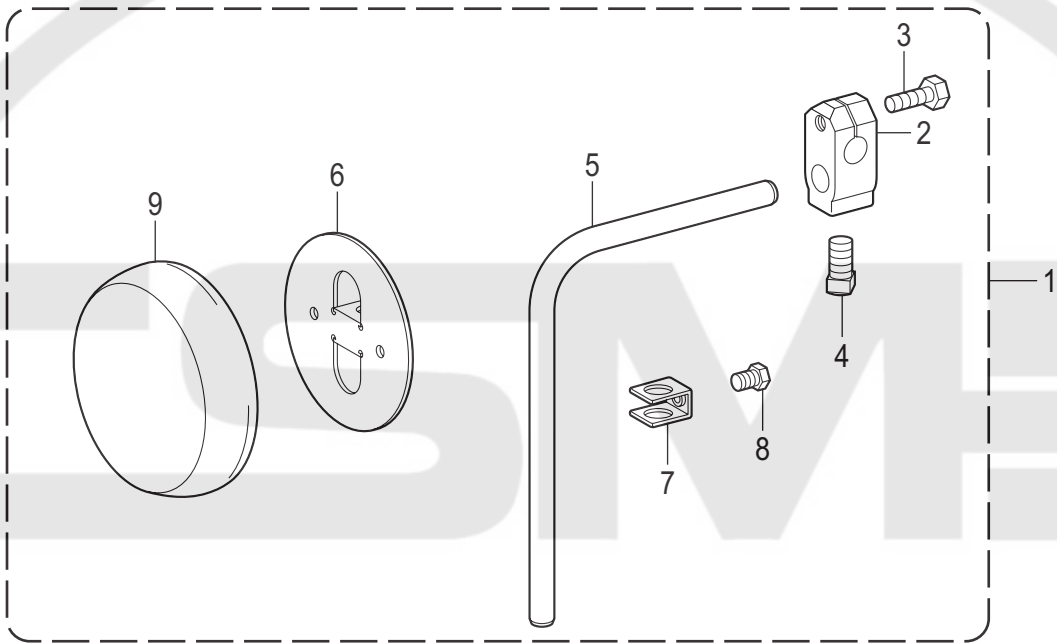

E. 膝控提升装置 / Knee lifter mechanism

参照号	零部件序号	数量	零部件名称	NAME OF PARTS	RM
1	SB3854001	1	膝控组件	KNEE LIFTER ASSY	
2	SB1603001	1	碰块弯杆接头	KNEE LIFTER BRACKET	
3	SB1604001	1	螺栓 M6X15	BOLT 6X15	
4	SB1605001	1	螺栓 M6X24	BOLT 6X24	
5	SB3480001	1	膝控弯管	KNEE LIFTER BAR	
6	SB1607001	1	膝控碰块	KNEE LIFTER PLATE	
7	SB1609001	1	碰块架	KNEE LIFTER PLATE STOPPER	
8	SB1610001	1	螺栓 M6X12	BOLT 6X12	
9	SB1611001	1	膝控碰块垫	KNEE LIFTER PLATE COVER	

F. 倒缝装置 / Quick reverse mechanism

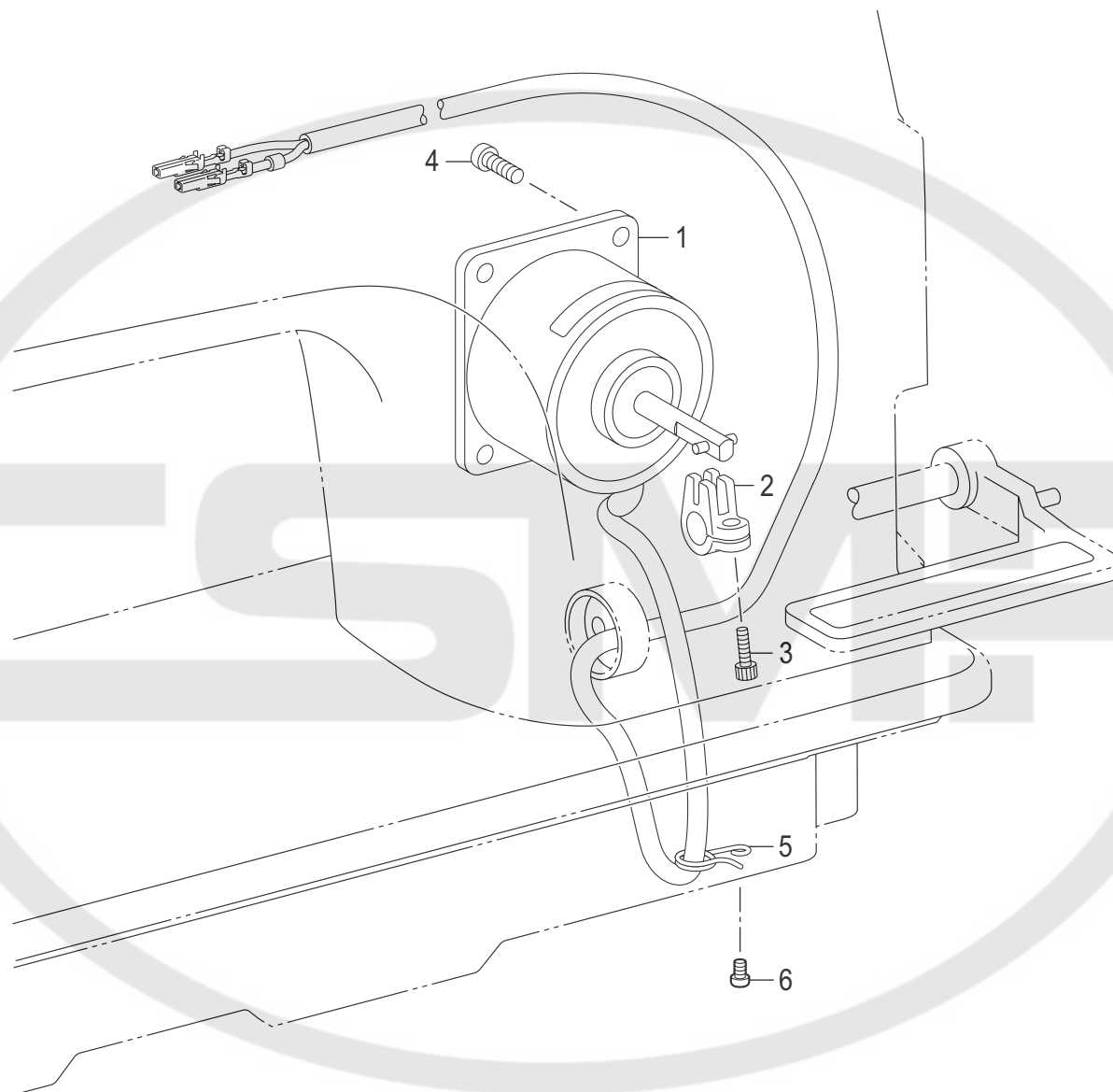

F. 倒缝装置 / Quick reverse mechanism

参照号	零部件序号	数量	零部件名称	NAME OF PARTS	RM
1	SB4022001	1	倒缝电磁铁	QUICK REVERSE SOLENOID	
2	S02600100	1	电磁铁拨叉	SOLENOID LEVER	
3	S07959001	1	螺钉 SM4.76-32X14	BOLT, SOCKET SM4.76-32X14	
4	062401216	3	螺钉 M4X12	SCREW PAN M4X12	
5	SB3993001	1	电线导向	HARNESS HOLDER	
6	062400616	1	螺钉 M4X6	SCREW PAN M4X6	

S-7000DD-205

G. 旋梭装置 / Rotary hook mechanism

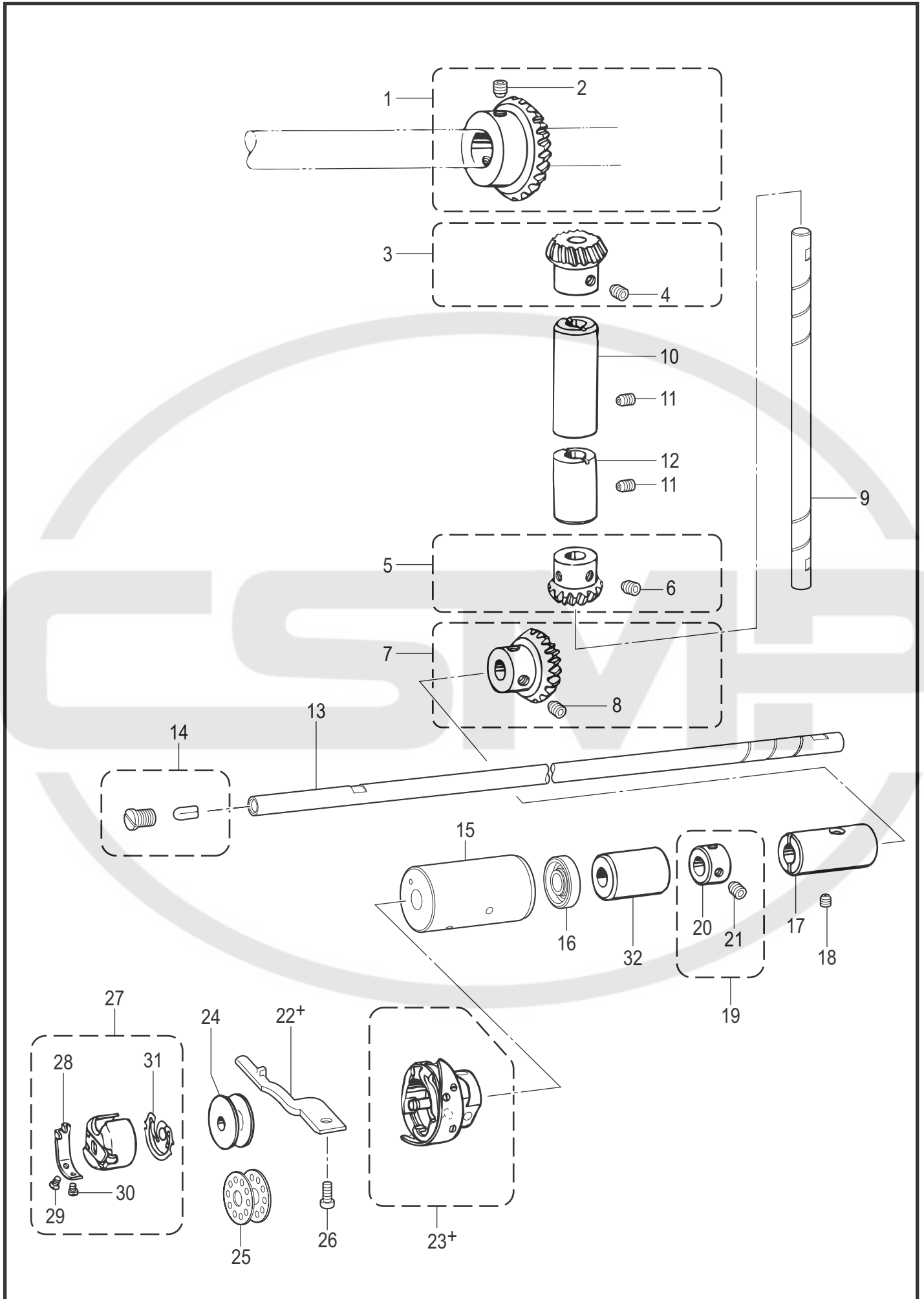

G. 旋梭装置 / Rotary hook mechanism

参照号	零部件序号	数量	零部件名称	NAME OF PARTS	RM
1	SA8159001	1	上轴伞齿轮组件	UPPER SHAFT BEVEL GEAR ASSY	
2	014770632	2	螺钉 SM6.35-40X6	SET SCREW SOCKET SM6.35-40X6	
3	SA8160001	1	竖轴伞齿轮组件 U	VERTICAL BEVEL GEAR ASSY U	
4	014770632	2	螺钉 SM6.35-40X6	SET SCREW SOCKET SM6.35-40X6	
5	SA8161001	1	竖轴伞齿轮组件 D	VERTICAL BEVEL GEAR ASSY D	
6	014770632	2	螺钉 SM6.35-40X6	SET SCREW SOCKET SM6.35-40X6	
7	SA8162001	1	下轴伞齿轮组件	LOWER SHAFT BEVEL GEAR ASSY	
8	014770632	2	螺钉 SM6.35-40X6	SET SCREW SOCKET SM6.35-40X6	
9	SB3490101	1	竖轴	VERTICAL SHAFT	
10	142708120	1	竖轴上轴套	VERTICAL SHAFT BUSH, U	
11	012060636	2	螺钉 M6X6	SET SCREW SOCKET (FT) M6X6	
12	SB3856001	1	竖轴下轴套	VERTICAL SHAFT BUSH D	
13	SB3491001	1	旋梭轴	ROTARY HOOK SHAFT	
14	SA9945201	1	油盖螺钉组件	SCREW CAP W/HOLE ASSY	
15	SB3493001	1	泵轴套	PUMP BUSH	
16	SA9684001	1	油封	OIL SEAL	
17	104520020	1	下轴右轴套	LOWER SHAFT BUSH, R	
18	012060636	1	螺钉 M6X6	SET SCREW SOCKET (FT) M6X6	
19	SB3796001	1	紧圈组件	SET SCREW COLLAR ASSY	
20	SB3797001	1	紧圈	SET SCREW COLLAR	
21	014770632	2	螺钉 SM6.35-40X6	SET SCREW SOCKET SM6.35-40X6	
22+	S02602021	1	<用于-□03, -□03A> 旋梭定位钩	<For -□03, -□03A> HOOK STOPPER	
23+	SB1305001	1	盒装旋梭组件 SB3338	ROTARY HOOK ASSY W/BOX SB3338	
24	146290021	1	梭芯	BOBBIN	
22+	159324021	1	<用于-□05> 旋梭定位钩	<For -□05> HOOK STOPPER	
23+	SB1677001	1	盒装旋梭组件 SB1678	ROTARY HOOK ASSY W/BOX SB1678	
25	117132001	1	梭芯	BOBBIN	
26	SA8903001	1	螺钉 M4X12	SCREW M4X12	
27	S06573001	1	梭心套组件	BOBBIN CASE ASSEMBLY	
28	183388001	1	梭芯套调整簧片	TENSION SPRING	
29	183389001	1	梭芯套调整螺钉	ADJUSTING SCREW	
30	183390001	1	固定螺钉	SET SCREW	
31	S06594001	1	空转防止弹簧	SPRING, ANTI-SPIN	
32	S31027020	1	下轴中轴套	LOWER SHAFT BUSH, M	

H. 供油润滑装置 / Lubrication

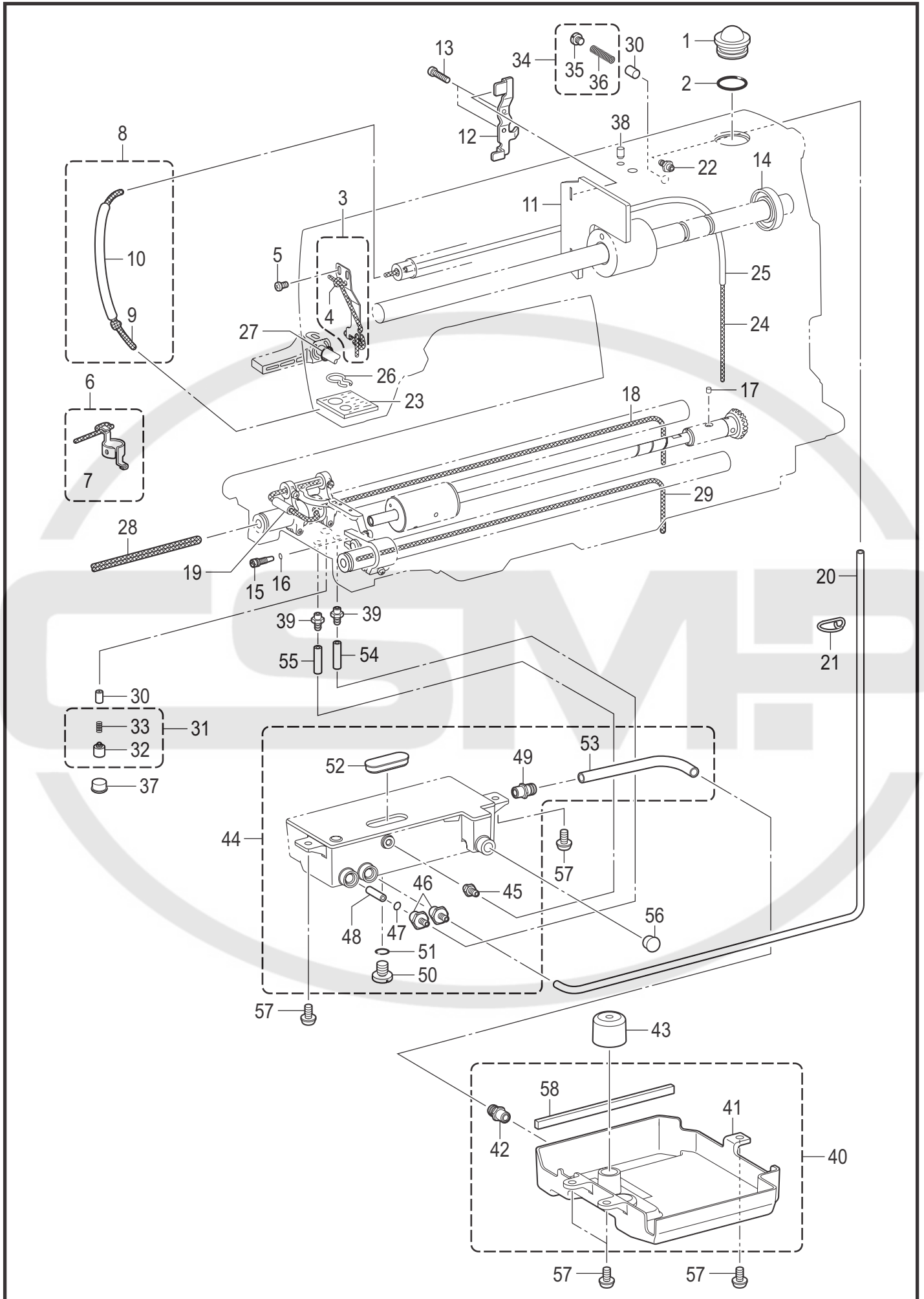

H. 供油润滑装置 / Lubrication

参照号	零部件序号	数量	零部件名称	NAME OF PARTS	RM
1	S02606020	1	油窗	OIL GAUGE WINDOW	
2	081014670	1	O形圈 PW14	O RING PW14	
3	SB3524001	1	油线夹组件 U	WICK HOLDER U ASSY	
4	SB3500001	1	油线 2X2	WICK 2X2	
5	062670616	2	螺钉 SM3.57-40X6	SCREW PAN SM3.57-40X6	
6	SA8167101	1	油线夹组件 D	WICK HOLDER D ASSY	
7	SA8169001	1	油线 2X2	WICK	
8	SB3501001	1	油管组件	TUBE ASSY	
9	SB3502001	1	油线 2X2	WICK 2X2	
10	SB3857001	1	维尼龙管 L=95	VINYL TUBE L=95	
11	SB3503001	1	油线挡板	OIL STOPPER PLATE	
12	SB3504001	1	油线挡板支架	OIL STOPPER PLATE SUPPORT	
13	062401616	2	螺钉 M4X16	SCREW PAN M4X16	
14	SB4015001	1	油封	OIL SEAL	
15	SB4527101	1	调节螺钉	ADJUSTING SCREW	
16	081004870	1	O形圈 S4	O RING S4	
17	107155001	1	油毡	FELT	
18	SB3505001	1	油线	WICK	
19	S40016001	1	油管 2X25	OIL TUBE 2X25	
20	SB3507001	1	维尼龙管	VINYL TUBE	
21	SB3992001	1	油管导向	TUBE GUIDE	
22	S25382001	1	供油口	OIL FEEDING PIPE	
23	S38769000	1	油毡	FELT	
24	SB3512001	1	油线	WICK	
25	SB3511001	1	维尼龙管	VINYL TUBE	
26	145737021	1	滤油毡压簧	FELT SUPPORT	
27	081004070	1	O形圈 P4	O RING P4	
28	S43669000	1	油线 8L=320	WICK, 8 L=320	
29	SB3514001	1	油线 4X4	WICK 4X4	
30	144875001	2	柱塞	PLUNGER	
31	SB3496001	1	泵盖螺钉组件	CAP SCREW PUMP ASSY	
32	SB3985001	1	泵盖螺钉	CAP SCREW PUMP	
33	S52764001	1	弹簧	SPRING COMPRESSION	
34	SB3522001	1	泵盖螺钉组件	PUMP CAP SCREW ASSY	
35	SB3523001	1	泵盖螺钉	CAP SCREW PUMP	
36	S52764001	1	弹簧	SPRING COMPRESSION	
37	104821001	1	橡皮塞 10.5	RUBBER CAP, 10.5	
38	SB2407001	1	橡皮塞 6.4	RUBBER CAP 6.4	
39	S25382001	2	供油口	OIL FEEDING PIPE	
40	SB3554201	1	油盖组件	OIL COVER ASSY	
41	SB3515001	1	油盖	OIL COVER	
42	SB4447101	1	供油口 12.2	OIL FEEDING PIPE 12.2	
43	SB3517001	1	膝控提升杆橡皮塞	KNEE LIFTER BAR RUBBER CAP	
44	SB3526101	1	油箱总组件	OIL TANK UNIT	
45	S25382001	1	供油口	OIL FEEDING PIPE	
46	SA8989001	2	供油口	OIL FEEDING PIPE	
47	081006670	1	O形圈 PW6	O RING PW6	
48	SA8987001	1	过滤毡	FILTER	
49	SB4447101	1	供油口 12.2	OIL FEEDING PIPE 12.2	
50	SA1303101	1	螺钉8	SCREW M8	
51	081008070	1	O形圈 P8	O RING P8	
52	SA8991001	1	橡皮塞35-12	RUBBER CAP 35-12	
53	SB3508001	1	维尼龙管	VINYL TUBE	
54	SB3509001	1	维尼龙管	VINYL TUBE	
55	SB4037001	1	维尼龙管	VINYL TUBE	
56	104450101	1	橡皮塞 8	RUBBER CAP, 8	
57	0A4501206	5	螺钉(带垫圈) M5X12DA	SCREW PAN (S/P WASHER) M5X12	
58	SB4448101	1	油盖垫片	OIL COVER PACKING	

S-7000DD-350

J. 穿线装置 / Threading mechanism

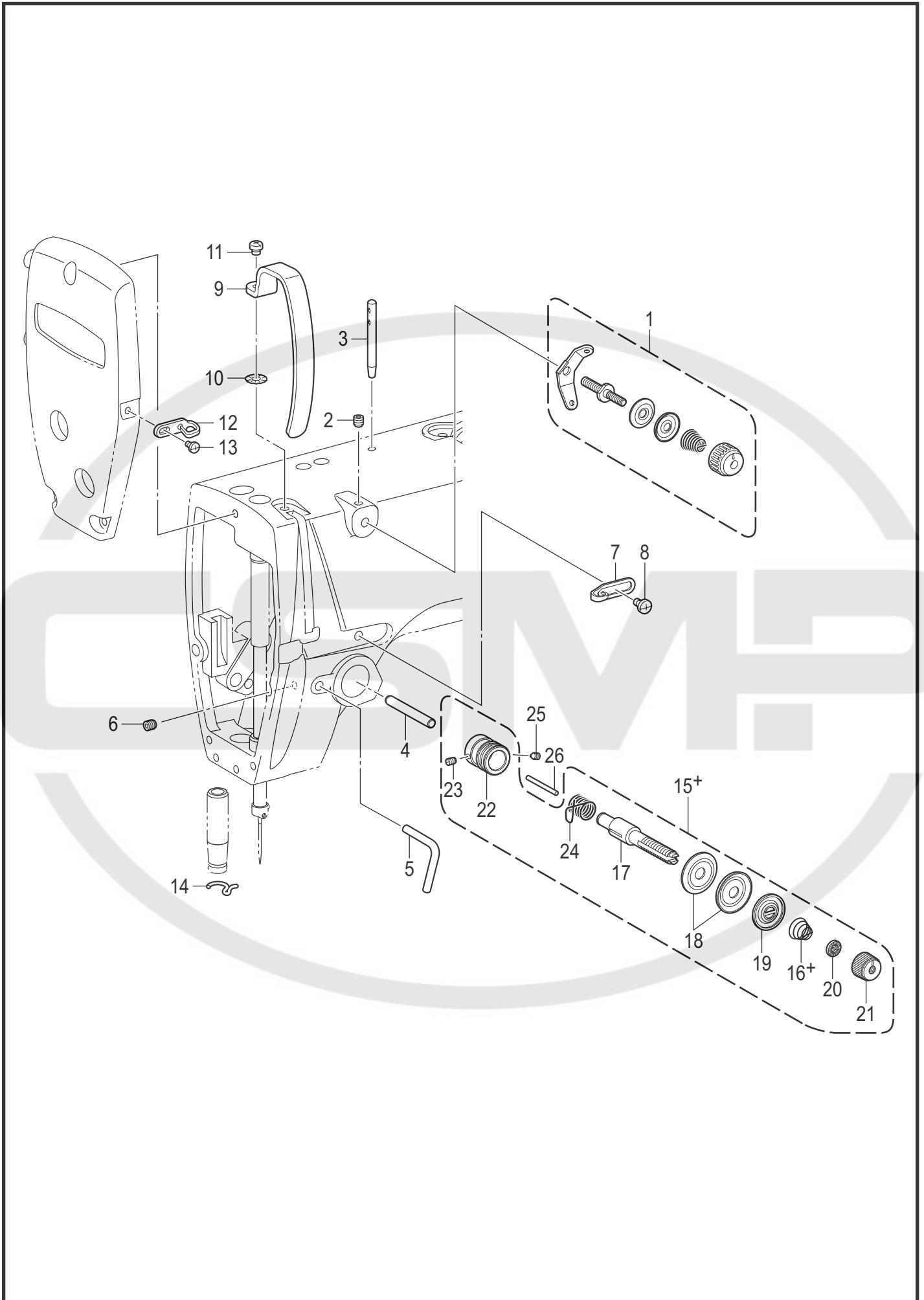

J. 穿线装置 / Threading mechanism

参照号	零部件序号	数量	零部件名称	NAME OF PARTS	RM
1	SB3483001	1	小夹线组件	PRE-TENSION ASSY	
2	012500536	1	螺钉 M5X5	SET SCREW SOCKET (FT) M5X5	
3	SB3595001	1	穿线杆	SPOOL PIN	
4	SA8178001	1	松线杆	TENSION RELEASE STUD	
5	SB3530001	1	线导向	ARM THREAD GUIDE	
6	012500536	1	螺钉 M5X5	SET SCREW SOCKET (FT) M5X5	
7	SA1345001	1	机壳线导向R	ARM THREAD GUIDE, R	
8	060500616	1	螺钉 M5X6	SCREW BIND M5X6	
9	SA9854001	1	挑线杆防护罩	THREAD TAKE-UP LEVER COVER	
10	SB0544001	1	止动圈	WASHER	
11	062500816	1	螺钉 M5X8	SCREW PAN M5X8	
12	S02617001	1	面板线钩	FACE PLATE THREAD GUIDE	
13	060350616	1	螺钉 M3.5X6	SCREW BIND M3.5X6	
14	SB3798001	1	线导向	THREAD GUIDE D	
15+	SB3572001	1	<用于-□03, -□03A> 夹线器组件	<For -□03, -□03A> THREAD TENSION BRACKET ASSY	
16+	104525102	1	夹线弹簧	TENSION SPRING	
15+	SB3574001	1	<用于-□05> 夹线器组件	<For -□05> THREAD TENSION BRACKET ASSY	
16+	S04632102	1	夹线弹簧	TENSION SPRING	
17	116922101	1	夹线螺杆	TENSION STUD	
18	145446021	2	夹线盘	DISC TENSION	
19	SB3618001	1	压线圈	TENSION DISC PRESSER	
20	SB4216001	1	止动垫圈	WASHER	
21	SB4038001	1	夹线螺母	TENSION NUT	
22	SB1600001	1	夹线器基座	THREAD TENSION BRACKET	
23	100402004	1	固定螺钉 SM3.57	SET SCREW SM3.57	
24	S02620401	1	挑线弹簧	THREAD TAKE-UP SPRING	
25	SA1229101	1	螺钉 M6X6	SET SCREW (FT) M6X6	
26	150551020	1	松线销	TENSION RELEASE PIN	

K. 绕线装置 / Bobbin winder mechanism

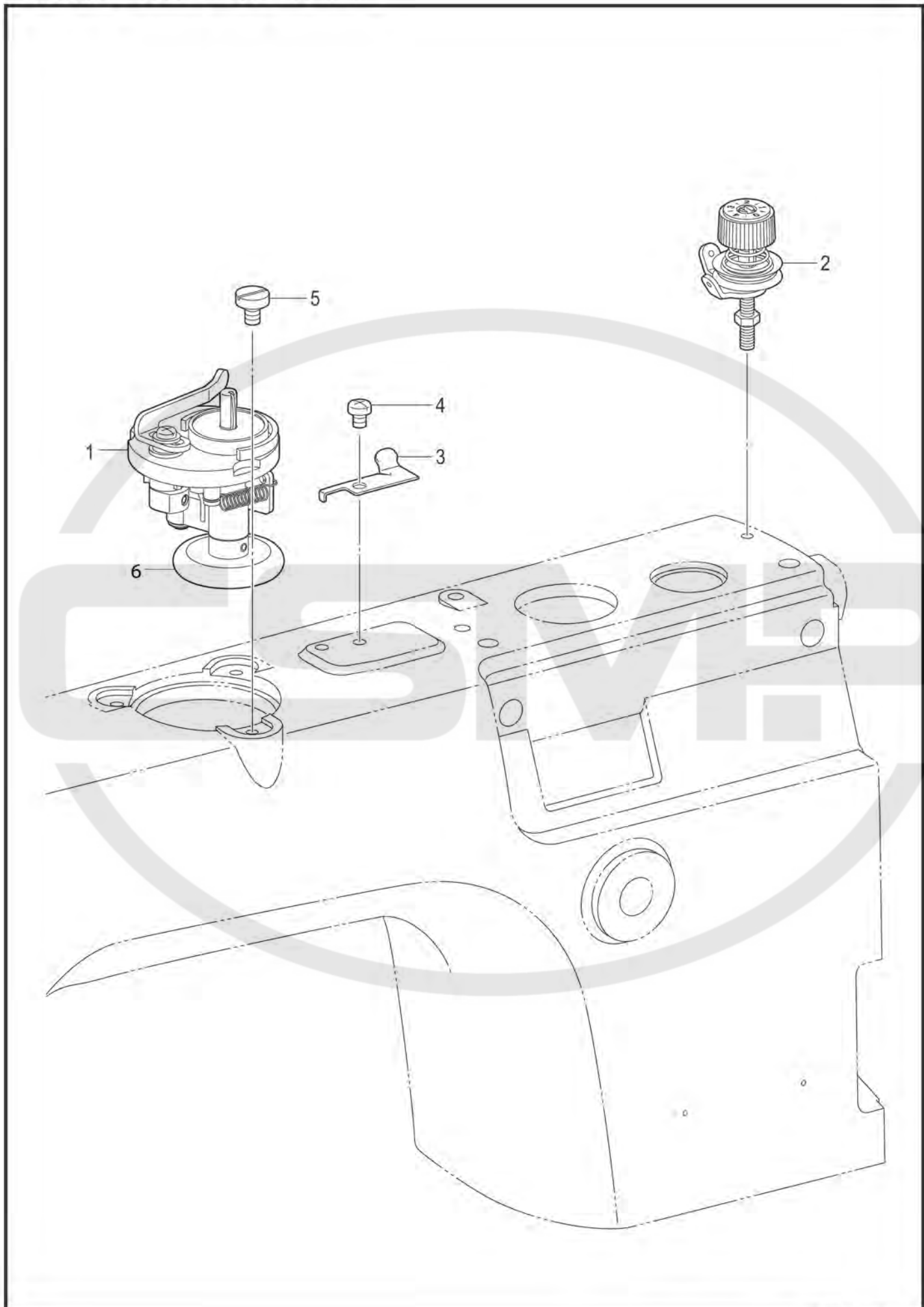

S-7000DD-402

K. 绕线装置 / Bobbin winder mechanism

参照号	零部件序号	数量	零部件名称	NAME OF PARTS	RM
1	SB3529101	1	绕线器组件	BOBBIN WINDER UNIT	
2	SB3571101	1	绕线器夹线组件	BOBBIN WINDER TENSION ASSY	
3	SA1360101	1	切刀	KNIFE	
4	062500616	1	螺钉 M5X6	SCREW PAN M5X6	
5	SB3619001	1	固定螺钉	BOBBIN WINDER FIXED SCREW	
6	SA8503001			BOBBIN WINDER RUBBER RING	

L. 切线装置 / Thread trimmer mechanism

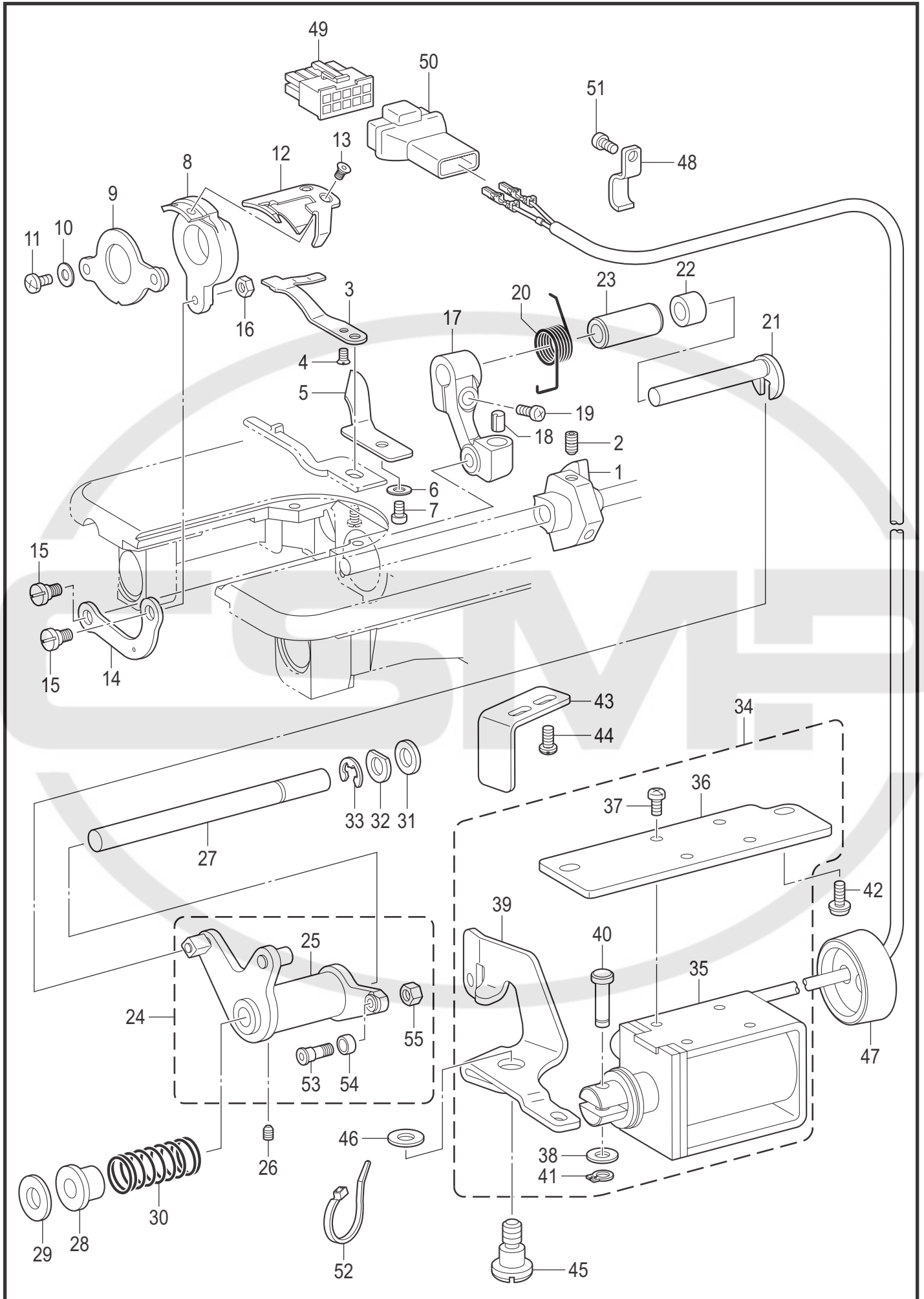

S-7000DD-403

L. 切线装置 / Thread trimmer mechanism

参照号	零部件序号	数量	零部件名称	NAME OF PARTS	RM
1	S00337021	1	切线凸轮	THREAD TRIMMER CAM	
2	014771032	2	固定螺钉 SM6.35-40X10	SET SCREW SOCKET SM6.35-40X10	
3	S02637101	1	固定刀	FIXED KNIFE	
4	102843004	1	平头螺钉 SM3.57	SCREW, FLAT SM3.57	
5	S02643001	1	分线器	LOWER THREAD FINGER	
6	100645003	1	垫圈	WASHER	
7	062400616	1	螺钉 M4X6	SCREW PAN M4X6	
8	SB3556001	1	刀架	MOVABLE KNIFE HOLDER	
9	SB3799001	1	刀架压板组件	KNIFE HOLDER PRESSER ASSY	
10	100645003	2	垫圈	WASHER	
11	060401216	2	螺钉 M4X12	SCREW BIND M4X12	
12	S02645001	1	动刀	MOVABLE KNIFE	
13	148537101	2	螺钉 SM4.37	SCREW, FLAT (W/SOCKET) SM4.37	
14	SB3557001	1	切线连杆	THREAD TRIMMER CONNECTING ROD	
15	151987022	2	轴位螺钉 SM4.37	SHOULDER SCREW, SM4.37	
16	105234003	1	螺母 SM4.37	NUT SM4.37	
17	SB3558001	1	切线手杆	THREAD TRIMMER LEVER	
18	SA7285101	1	手杆定位	LEVER STOPPER	
19	062501416	1	螺钉 M5X14	SCREW PAN M5X14	
20	SB3559001	1	弹簧	SPRING EXTENSION	
21	SB3802001	1	切刀驱动曲柄轴	FORKED SHAFT	
22	S02648021	1	曲柄轴套	COLLAR	
23	SB3803001	1	叉轴轴套	FORKED SHAFT BUSH	
24	SB3852001	1	切线凸轮杆总组件	THREAD TRIMMER CAM LEVER UNIT	
25	SB3853001	1	切线凸轮杆组件	THREAD TRIMMER CAM LEVER ASSY	
26	012060636	1	螺钉 M6X6	SET SCREW SOCKET (FT) M6X6	
27	154593321	1	切刀驱动轴	THREAD TRIMMER CAM LEVER SHAFT	
28	154594020	1	挡圈	COLLAR	
29	S25434000	1	橡皮垫圈	RUBBER CUSHION	
30	154595001	1	切线凸轮复位弹簧	SPRING, EXTENSION	
31	154596000	1	减震垫圈	CUSHION	
32	110367001	1	垫圈 8	WASHER, PLAIN SPECIAL 8	
33	048060342	1	挡圈 E6	RETAINING RING E6	
34	SB3563001	1	切线电磁铁组件	THREAD TRIMMER SOLENOID ASSY	
35	SB3568001	1	切线电磁铁	THREAD TRIMMER SOLENOID	
36	SB3569001	1	电磁铁安装板	SOLENOID BASE	
37	062400816	4	螺钉 M4X8	SCREW PAN M4X8	
38	026050136	1	平垫圈 S5	WASHER PLAIN S 5	
39	SB3564001	1	电磁铁杆	SOLENOID LEVER	
40	SA9716001	1	销	PIN	
41	048050142	1	轴用挡圈 C5	RETAINING RING EXTERNAL C5	
42	062501016	2	螺钉 M5X10	SCREW PAN M5X10	
43	SB3565001	1	电磁铁杆定位板	SOLENOID STOPPER	
44	062400616	2	螺钉 M4X6	SCREW PAN M4X6	
45	SB3566001	1	轴位螺钉 M6	SHOULDER SCREW M6	
46	155559021	1	平垫圈	WASHER PLAIN	
47	SB3567001	1	橡皮塞 25.5	RUBBER CAP 25.5	
48	SA1388101	1	线夹	CORD HOLDER	
49	A10369001	1	插头 5557-12R	CONNECTOR 5557-12R	
50	SB4490001	1	插头套	SOLENOID CONNECTOR CAP	
51	060400616	1	螺钉 M4X6	SCREW BIND M4X6	
52	S04159000	3	线夹1M	BAND 1M	
53	SB3804001	1	滚轮轴 C	ROLLER SHAFT C	
54	SB3805001	1	滚轮	ROLLER	
55	105234003	1	螺母 SM4.37	NUT SM4.37	

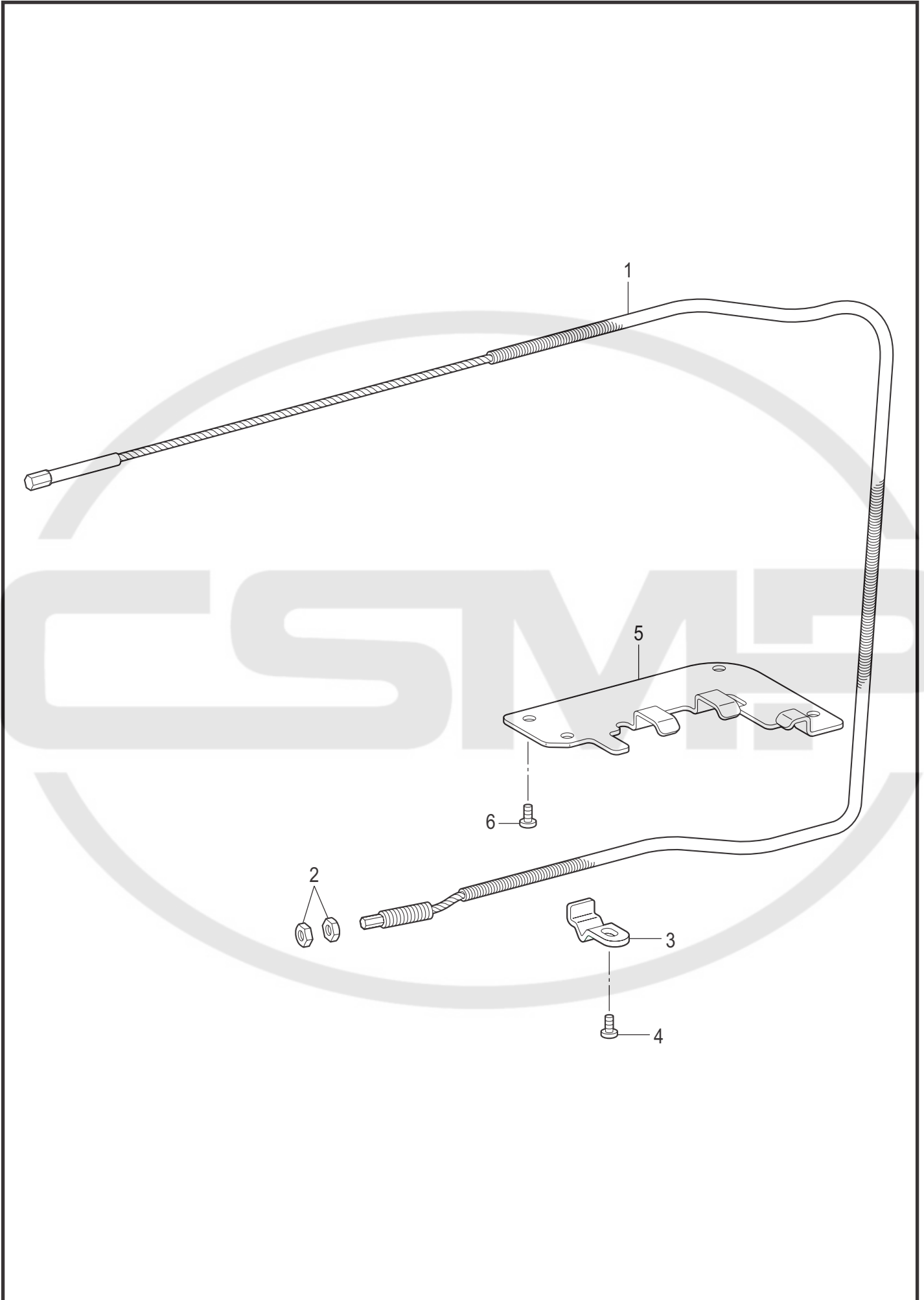

M. 松线装置 / Tension release mechanism

参照号	零部件序号	数量	零部件名称	NAME OF PARTS	RM
1	SB3576001	1	松线钢绳	TENSION RELEASE WIRE	
2	SB3877001	2	螺母 SM4.76	NUT SM4.76	
3	SB3999101	1	钢绳固定板	WIRE HOLDER	
4	062400616	1	螺钉 M4X6	SCREW PAN M4X6	
5	SB3575001	1	钢绳导向板	WIRE HOLDER	
6	062400616	4	螺钉 M4X6	SCREW PAN M4X6	

S-7000DD-404

N. 扫线装置 (-40□ 零部件或选购件) / Thread wiper mechanism (-40□ or option parts)

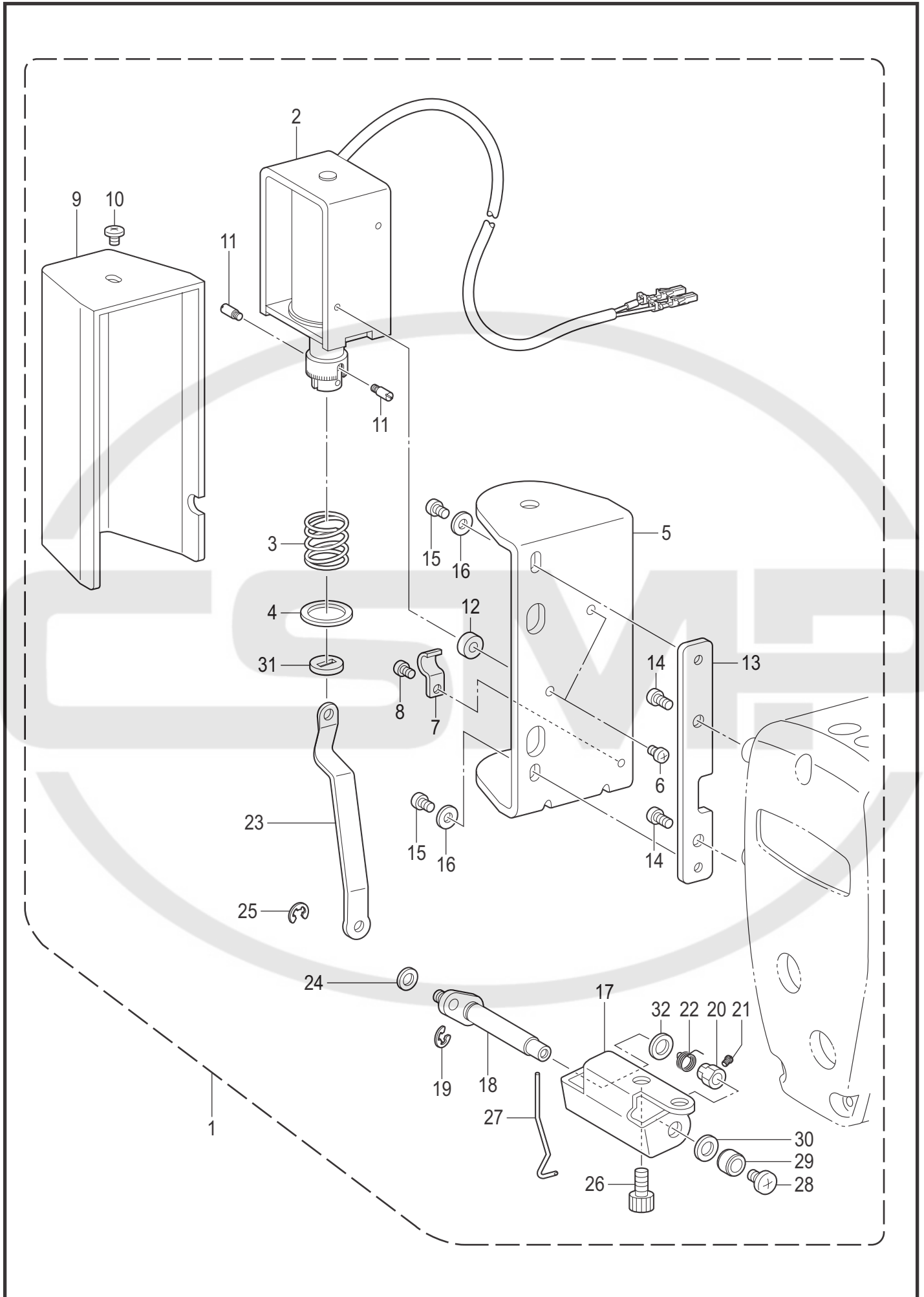

N. 扫线装置 (-40□零部件或选购件) / Thread wiper mechanism (-40□ or option parts)

参照号	零部件序号	数量	零部件名称	NAME OF PARTS	RM
1	SB4310001	1	扫线装置组件	THREAD WIPER DEVICE ASSY	
2	SB4201001	1	挡线电磁铁	THREAD WIPER SOLENOID	
3	SA9771001	1	挡线弹簧	THREAD WIPER SPRING	
4	S41205001	1	平垫圈	WASHER, PLAIN	
5	SB0609001	1	电磁铁安装板	SOLENOID SETTING PLATE	
6	062301016	2	螺钉 M3X10	SCREW PAN M3X10	
7	140647121	1	电线固定夹	CORD HOLDER	
8	062300616	1	螺钉 M3X6	SCREW PAN M3X6	
9	S33610122	1	电磁铁罩	SOLENOID COVER	
10	060400616	1	螺钉 M4X6	SCREW BIND M4X6	
11	S25456021	2	柱塞销	PLUNGER PIN	
12	SB0611001	2	垫圈	SPACER	
13	SB0610001	1	电磁铁安装架	SOLENOID SETTING BASE	
14	062681012	2	螺钉 SM4.37-40X10	SCREW PAN SM4.37-40X10	
15	062400616	2	螺钉 M4X6	SCREW PAN M4X6	
16	026040236	2	平垫圈 M4	WASHER PLAIN M 4	
17	S02672022	1	挡线轴架	THREAD WIPER SUPPORT	
18	S25452021	1	挡线曲柄轴组件	THREAD WIPER CRANK ASSY	
19	048040342	1	挡圈 E4	RETAINING RING E4	
20	S25454021	1	螺纹紧圈	SET SCREW COLLAR	
21	S25279101	1	螺钉 M3.5-5	SET SCREW (CP) M3.5-5	
22	S02678001	1	挡线弹簧	WIPER SPRING	
23	SA8189001	1	挡线连杆	THREAD WIPER LINK	
24	110735022	1	垫圈	WASHER	
25	048030342	1	挡圈 E3	RETAINING RING E3	
26	S59890001	2	螺栓SM4.37-40X8	BOLT, SOCKET SM4.37-40X8	
27	S02681101	1	挡线钩	THREAD WIPER	
28	060400516	1	螺钉 M4X5	SCREW BIND M4X5	
29	146288021	1	挡线轴挡圈	THREAD WIPER STUD COLLAR	
30	025750132	1	平垫圈 S 5.56	WASHER PLAIN S SM5.56	
31	S41207000	1	橡皮垫圈	SPACER RUBBER	
32	149097000	1	消音垫	SILENT SHEET	

P1. 控制箱 / Control box

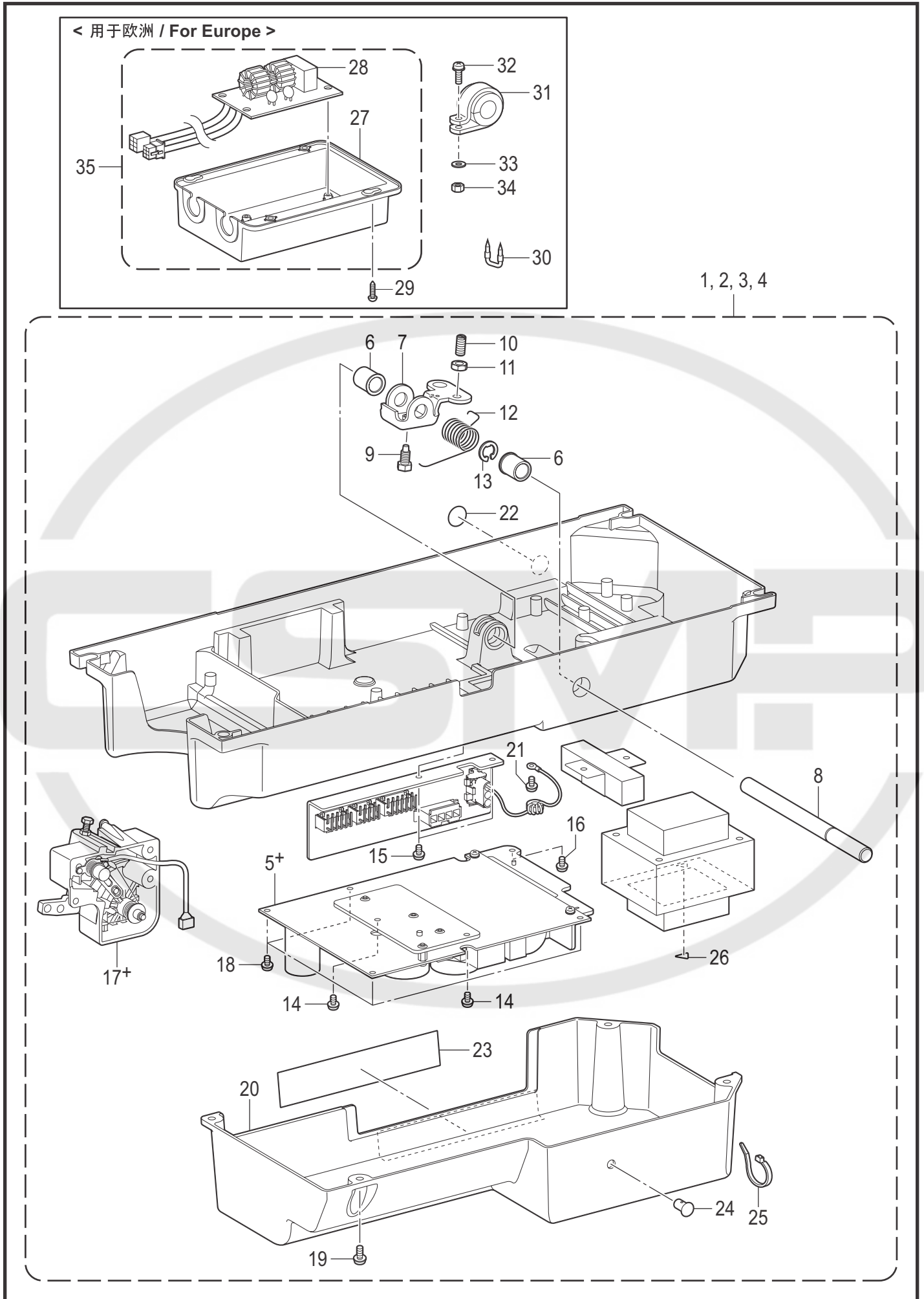

P1. 控制箱 / Control box

参照号	零部件序号	数量	零部件名称	NAME OF PARTS	RM
1	SB4580001	1	<用于中国> 备用7000DD控制箱组件 CN	<For China> 7000DD BOX ASSY CN SUPPLY	
2	SB4581001	1	<用于一般出口> 备用7000DD控制箱组件 EX	<For General> 7000DD BOX ASSY EX SUPPLY	
3	SB4582001	1	<用于美洲> 备用7000DD控制箱组件 US	<For the Americas> 7000DD BOX ASSY US SUPPLY	
4	SB4583001	1	<用于欧洲> 备用7000DD控制箱组件 CE	<For Europe> 7000DD BOX ASSY CE SUPPLY	
5+	SB4584001	1	<用于中国> 备用主基板组件 CN	<For China> MAIN PCB ASSY CN SUPPLY	
5+	SB4585001	1	<用于中国以外> 备用主基板组件 EX	<Except for China> MAIN PCB ASSY EX SUPPLY	
6	149578020	2	轴套	BUSH	
7	SB3584001	1	膝控	KNEE LIFTER	
8	SB3585001	1	膝控横轴	KNEE LIFTER SHAFT	
9	SB3586001	1	螺栓 SM5.95	BOLT SM5.95	
10	SB3587001	1	固定螺钉 SM5.95	SET SCREW SM5.95	
11	100022004	1	螺母 SM5.95	NUT SM5.95	
12	SB3588001	1	复位弹簧	TWIST SPRING	
13	146293001	1	挡圈 E10	RETAINING RING E10	
14	0A4400806	2	螺钉(带垫圈) M4X8DA	SCREW PAN (S/P WASHER) M4X8	
15	0A4400806	2	螺钉(带垫圈) M4X8DA	SCREW PAN (S/P WASHER) M4X8	
16	0A4400806	1	螺钉(带垫圈) M4X8DA	SCREW PAN (S/P WASHER) M4X8	
17+	SB3816101	1	<用于中国> 踏板控制器组件 CN	<For China> TREADLE UNIT CN	
17+	SB3817201	1	<用于一般出口> 踏板控制器组件 EX	<For General> TREADLE UNIT EX	
17+	SB4587101	1	<用于美洲和欧洲> 踏板控制器组件 US	<For the Americas and Europe> TREADLE UNIT US	
18	0A5501206	4	螺钉(带垫圈) M5X12	SCREW PAN (S/P WASHER) M5X12	
19	0A5501206	4	螺钉(带垫圈) M5X12	SCREW PAN (S/P WASHER) M5X12	
20	SB3589001	1	箱盖	BOX COVER	
21	0A4400806	1	螺钉(带垫圈) M4X8DA	SCREW PAN (S/P WASHER) M4X8	
22	S37060001	1	接地标记	LABEL, GROUNDING	
23	SA9725001	1	感电标签 36 X 150	LABEL ELECTRICAL SHOCK 36X150	
24	SB3872001	1	箱盖销	BOX COVER PIN	
25	SB4155001	1	线夹	BAND	
26	SB0827001	1	高温标志	HIGH TEMP LABEL	
27	SA9564001	1	<用于欧洲> CE滤波器座罩	<For Europe> CE FILTER CASE	
28	SA9565001	1	CE滤波器基板组件	CE FILTER PCB ASSY	
29	032461606	4	木螺钉 M4.5X16	WOOD SCREW ROUND 2 M4.5X16	
30	200190001	5	U形卡钉	STAPLE 10X20	
31	S52164000	2	衰减器 NFC-28	CORE: NFC-28	
32	0A5401605	2	螺钉(带垫圈) M4X16	SCREW PAN (S/P WASHER) M4X16	
33	025040236	2	平垫圈 M4	WASHER PLAIN M 4	
34	021400106	2	六角螺母 M4	NUT 1 M4	
35	SA9559001	1	CE滤波器组件	CE FILTER BOX ASSY	

1+

< 用于 单相 100V / 110V
For Single phase 100V / 110V >

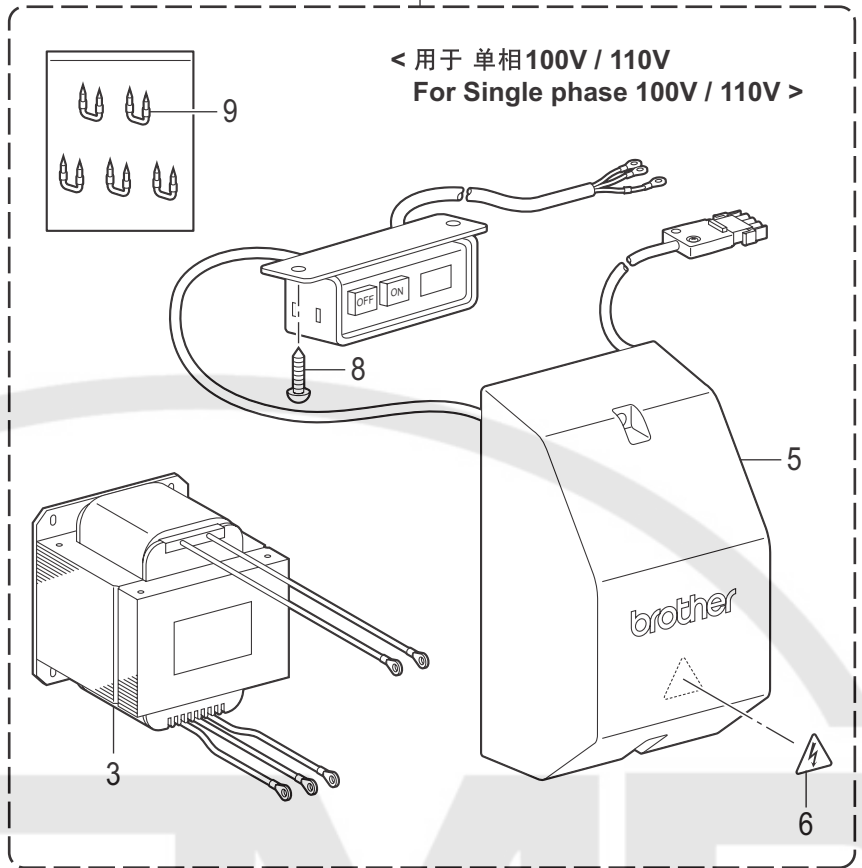
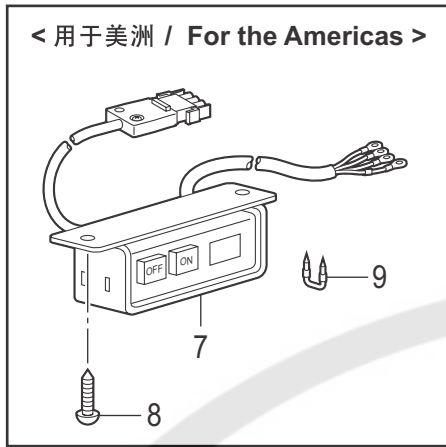

2+

< 用于 三相 380V / 400V
For Three phase 380V / 400V >

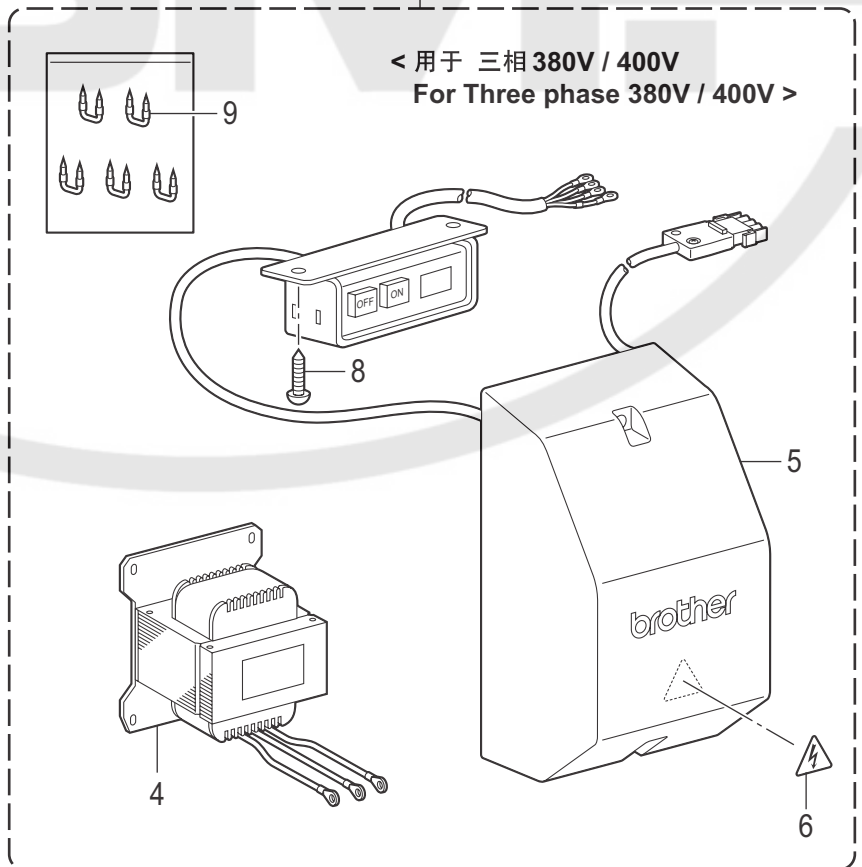
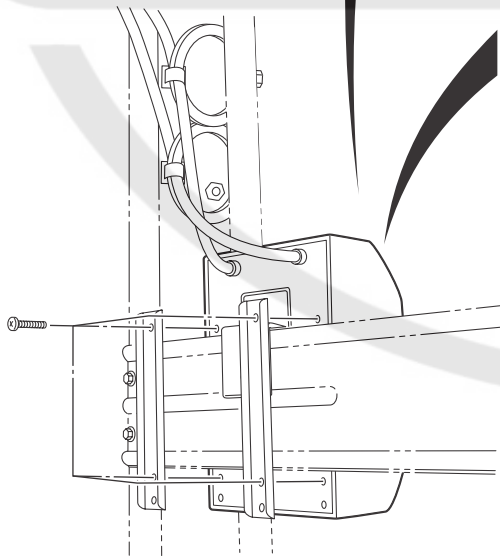

P2. 控制箱 / Control box

参照号	零部件序号	数量	零部件名称	NAME OF PARTS	RM
1+	BMP3010-0000000-AST1	1	<用于100V> 变压器箱	<For 100V> TRANSFORMER BOX	
1+	BMP3010-0000000-2ST1	1	<用于110V> 变压器箱	<For 110V> TRANSFORMER BOX	
2+	BMP3010-0000000-3ST4	1	<用于380V> 变压器箱	<For 380V> TRANSFORMER BOX	
2+	BMP3010-0000000-4ST4	1	<用于400V> 变压器箱	<For 400V> TRANSFORMER BOX	
3	SA9923001	1	<用于单相 100V/110V> 变压器 100/110/220V	<For Single phase 100V/110V> TRANSFORMER 100/110/220V	
4	SA9901001	1	<用于三相 380V/400V> 变压器 400/230V	<For Three phase 380V/400V> TRANSFORMER 400/230V	
5	SA9896001	1	变压器罩盖	TR BOX COVER	
6	SA9914001	1	感电标签 25 X 28	LABEL ELECTRICAL SHOCK 25X28	
7	SA9831001	1	<用于美洲> 电源开关组件 SJT#2	<For the Americas> POWER SWITCH ASSY SJT#2	
8	032461606	2	木螺钉 M4.5X16	WOOD SCREW ROUND 2 M4.5X16	
9	200190001	5	U形卡钉	STAPLE 10X20	

S-7000DD-502

Q. 倒缝开关装置 / Quick reverse switch mechanism

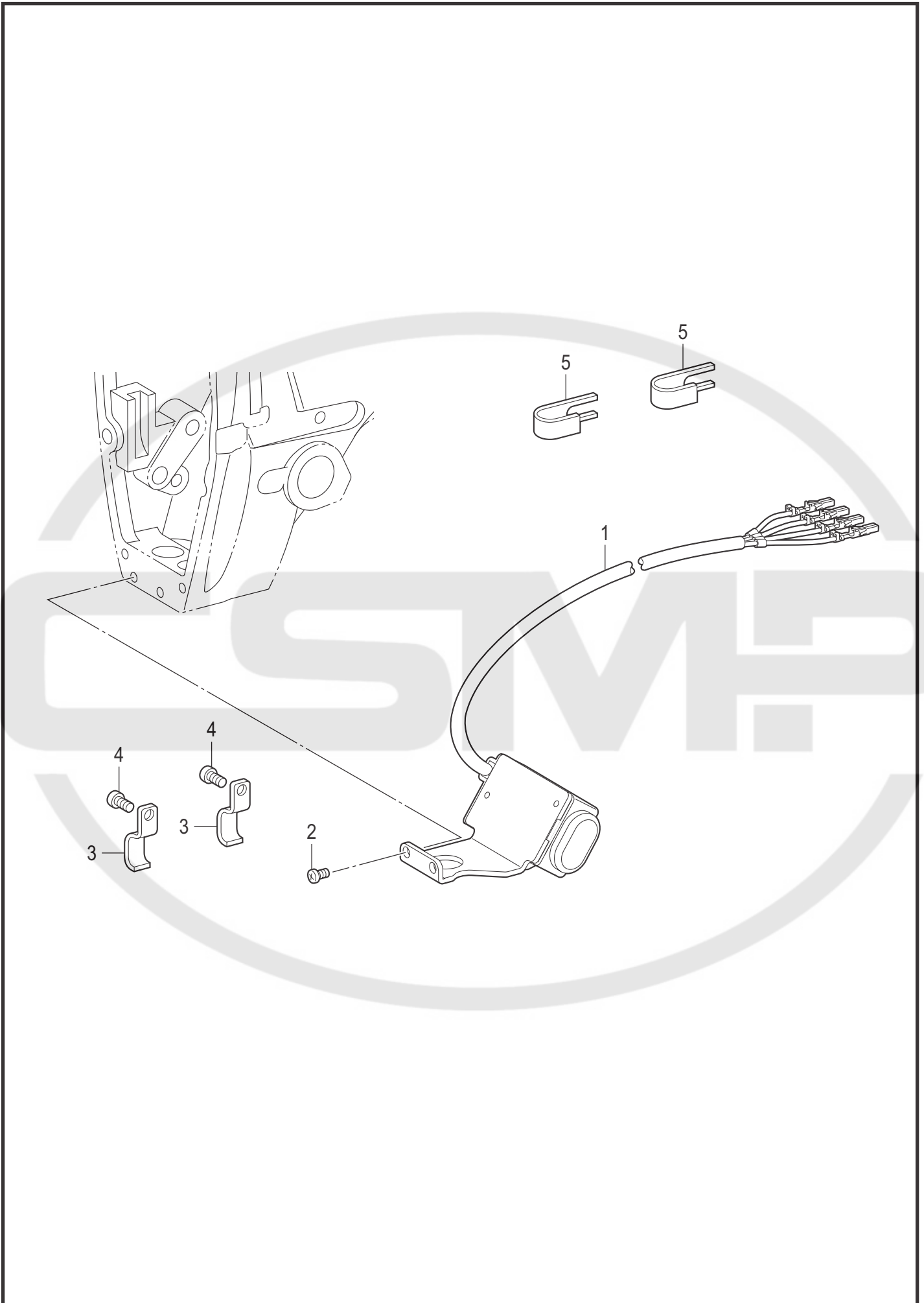

S-7000DD-508

Q. 倒缝开关装置 / Quick reverse switch mechanism

参照号	零部件序号	数量	零部件名称	NAME OF PARTS	RM
1	SB4086001	1	LED倒缝开关组件	LED REVERSE SW ASSY	
2	062670612	2	螺钉 SM3.57-40X6	SCREW PAN SM3.57-40X6	
3	SA8193001	2	电线夹 U2	CORD HOLDER U2	
4	062670612	2	螺钉 SM3.57-40X6	SCREW PAN SM3.57-40X6	
5	SB2408101	2	电线夹	CORD HOLDER	

S-7000DD-508

< 用于欧洲和美洲以外 / Except for Europe and the Americas >

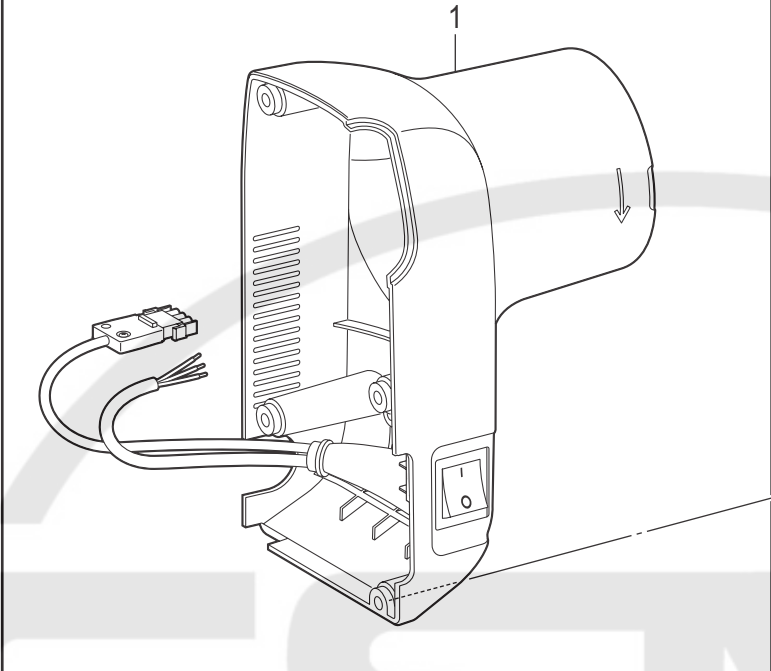

< 用于欧洲和美洲 / For Europe and the Americas >

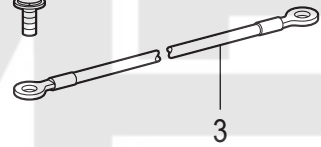
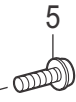
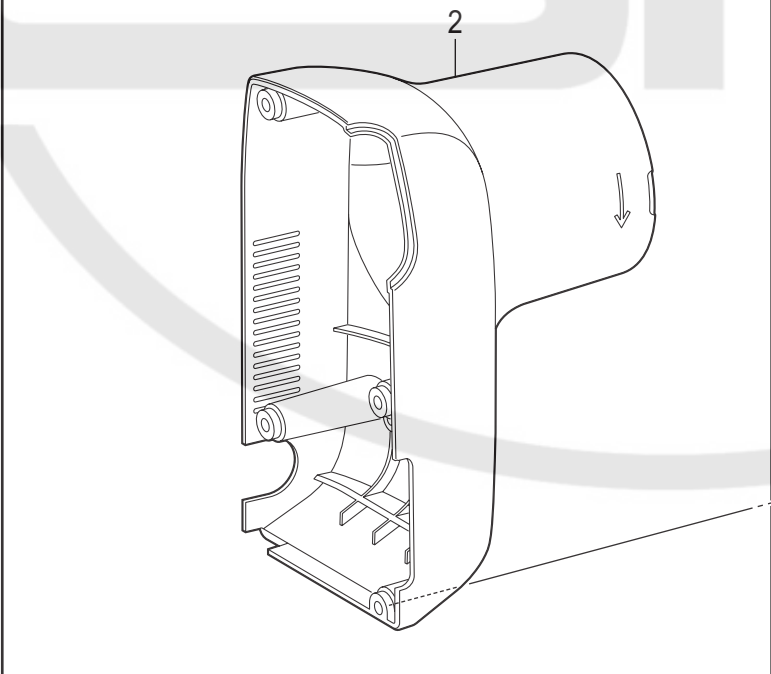

R. 电气部品 / Power supply equipment

参照号	零部件序号	数量	零部件名称	NAME OF PARTS	RM
1	SB3834001	1	<用于欧洲和美洲以外> 马达罩盖组件	<Except for Europe and the Americas> MOTOR COVER ASSY	
2	SB3620001	1	<用于欧洲和美洲> 马达罩盖 EX	<For Europe and the Americas> MOTOR COVER EX	
3	SB3621001	1	接地线	GROUND WIRE	
4	0A4400806	1	螺钉(带垫圈) M4X8DA	SCREW PAN (S/P WASHER) M4X8	
5	0A4501606	4	螺钉(带垫圈) M5X16DA	SCREW PAN (S/P WASHER) M5X16	

S-7000DD-515

S. 马达装置和操作盘 / Motor mechanism and operation panel

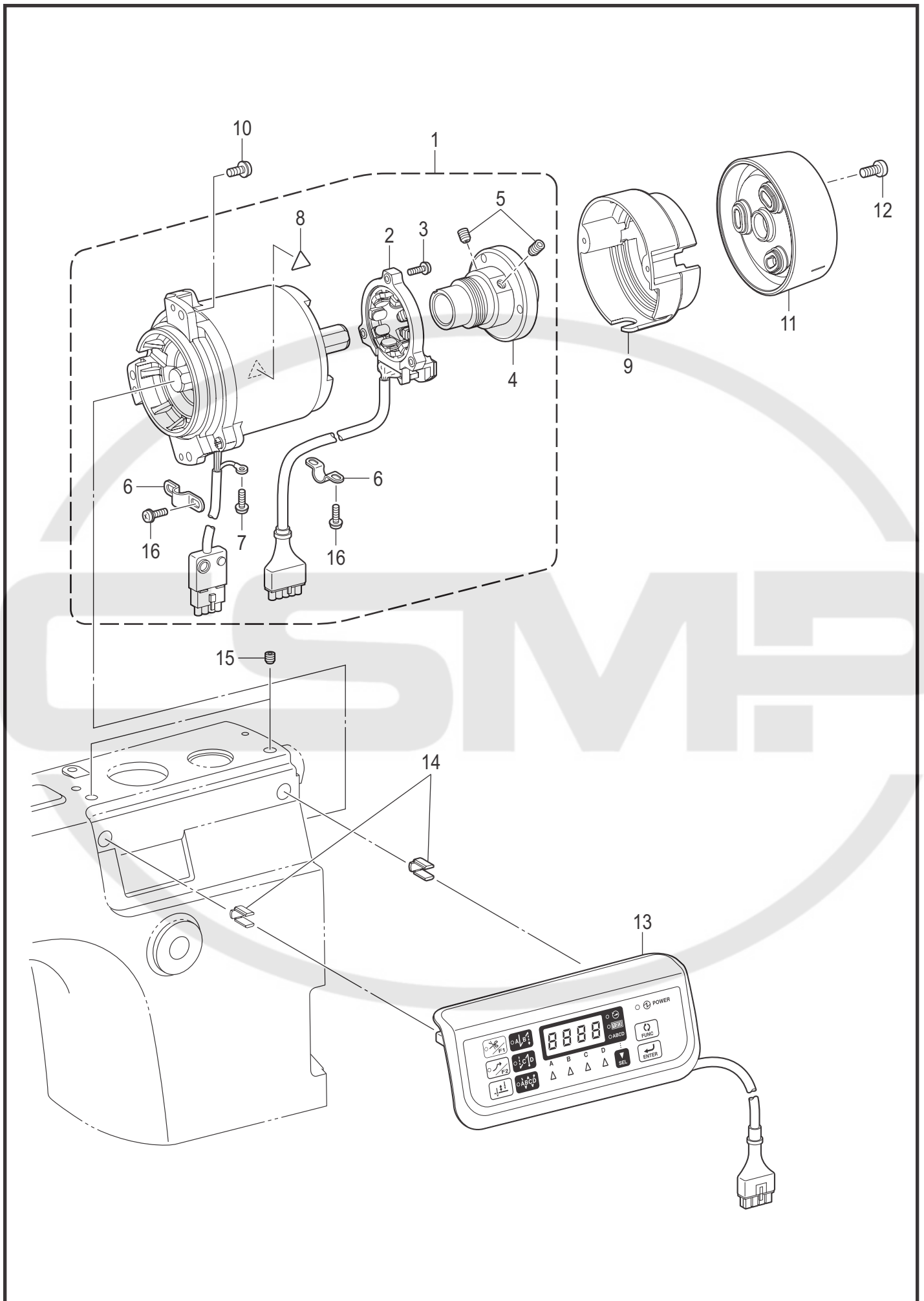

S. 马达装置和操作盘 / Motor mechanism and operation panel

参照号	零部件序号	数量	零部件名称	NAME OF PARTS	RM
1	SB4311001	1	备用马达(7000DD)组件	MOTOR 7000DD SUPPLY	
2	SB3609001	1	传感定子组件	RESOLVER STATOR ASSY	
3	0A4301206	3	螺钉(带垫圈) M3X12DA	SCREW PAN (S/P WASHER) M3X12	
4	SB2315001	1	上带轮保持架组件	PULLEY HOLDER ASSY	
5	012501032	2	螺钉 M5X10	SET SCREW SOCKET (FT) M5X10	
6	SB2317001	2	线夹	CORD HOLDER	
7	0A4400806	1	螺钉(带垫圈) M4X8DA	SCREW PAN (S/P WASHER) M4X8	
8	SB0827001	1	高温标志	HIGH TEMP LABEL	
9	SB3247001	1	传感定子罩	RESOLVER COVER	
10	0A4501606	3	螺钉(带垫圈) M5X16DA	SCREW PAN (S/P WASHER) M5X16	
11	SB4154001	1	上轮	PULLEY	
12	060501016	3	螺钉 M5X10	SCREW BIND M5X10	
13	SB3652201	1	操作盘组件	PANEL ASSY	
14	SB3655001	2	操作盘支座	PANEL SUPPORT	
15	012500536	2	螺钉 M5X5	SET SCREW SOCKET (FT) M5X5	
16	0A4300806	4	螺钉(带垫圈) M3X8DA	SCREW PAN (S/P WASHER) M3X8	

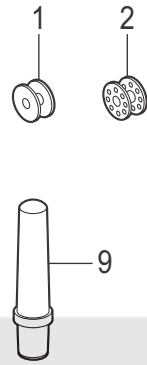
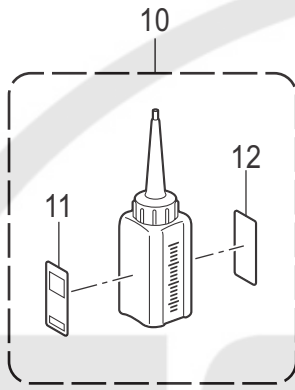
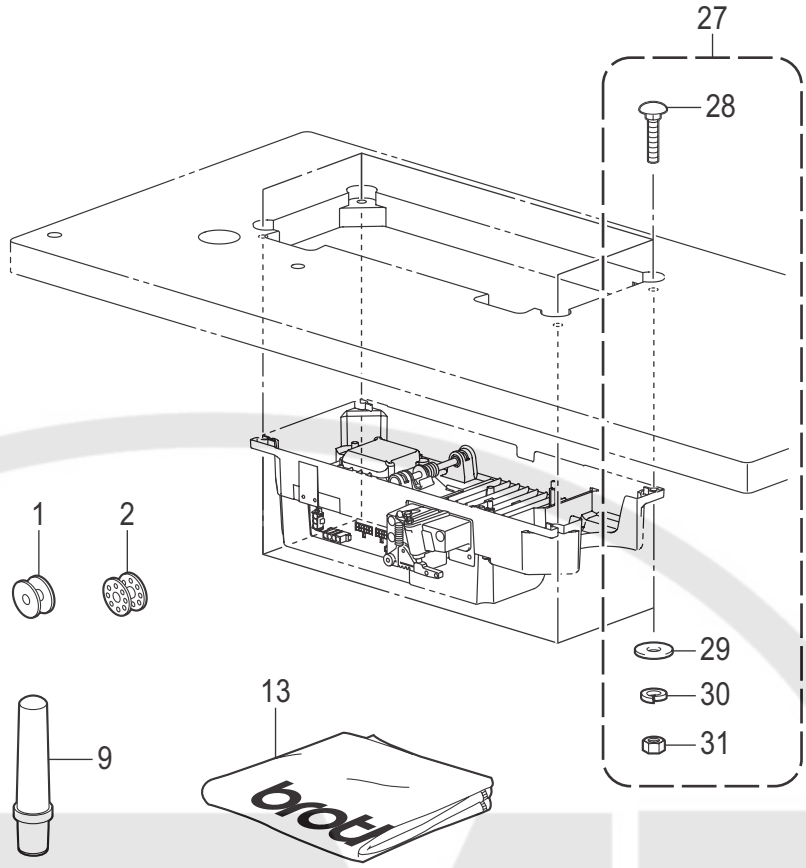
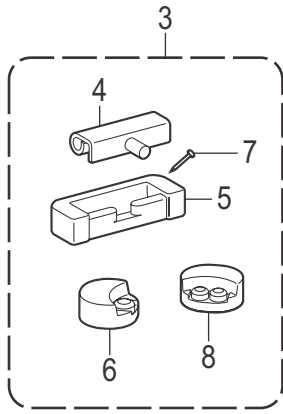



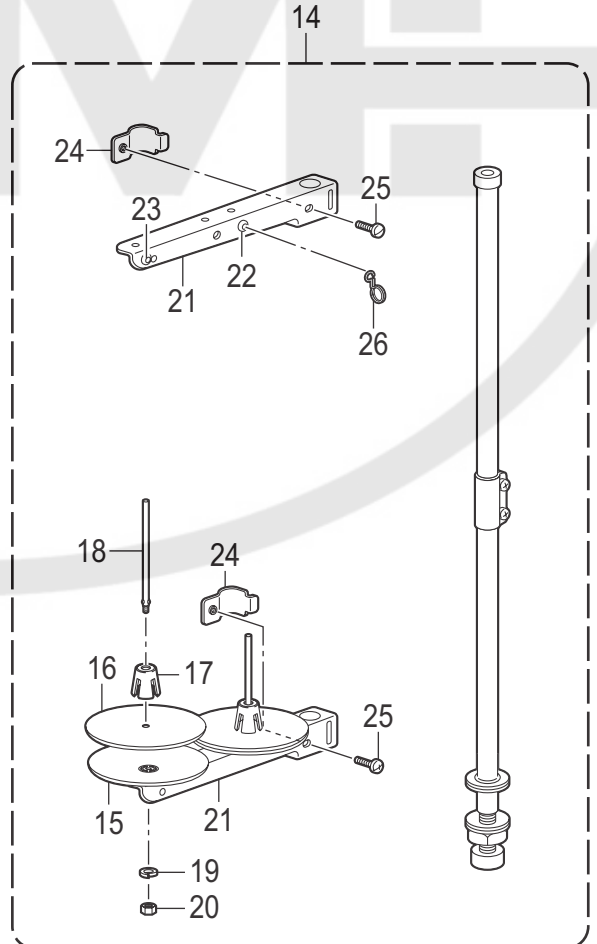
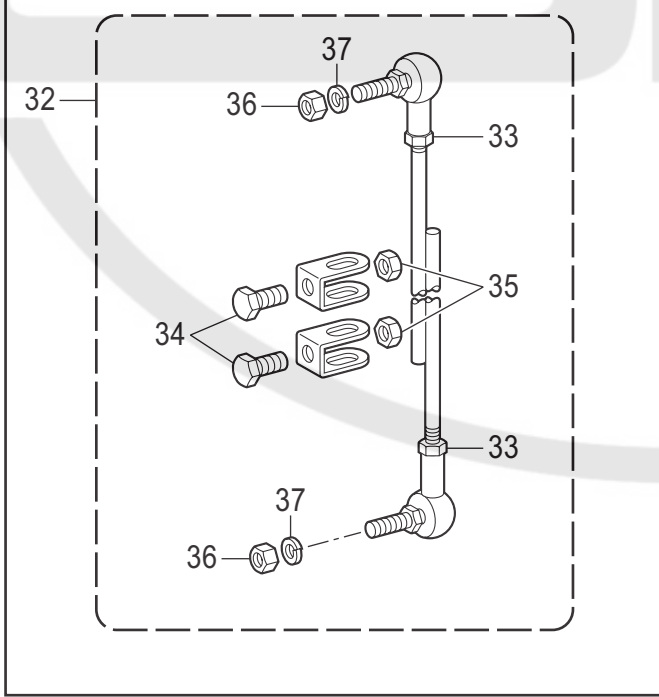

< 选购件 / Option parts >

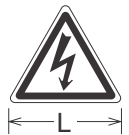

Z. 附件 / Accessories

参照号	零部件序号	数量	零部件名称	NAME OF PARTS	RM
1	146290021	1	<用于-□03, -□03A> 梭芯	<For -□03, -□03A> BOBBIN	
2	117132001	1	<用于-□05> 梭芯	<For -□05> BOBBIN	
3	SB3622001	1	橡胶铰链组件	RUBBER HINGE ASSY	
4	SB3627001	2	机头铰链	HEAD HINGE	
5	SB3628001	2	机头铰链套	RUBBER CUSHION	
6	SB3623101	2	头部防震垫	HEAD CUSHION	
7	109714020	4	钉	NAIL	
8	SB4018101	2	头部防震垫	HEAD CUSHION	
9	SB3629001	1	机头撑杆 S	HEAD REST S	
10	SA8239201	1	油壶组件	OIL TANK ASSY	
11	SB1270001	1	油壶警示标贴 英文	OIL WARNING LABEL EN	
12	SB1271001	1	油壶警示标贴 日文	OIL WARNING LABEL JP	
13	SB3876001	1	机头罩	HEAD COVER	
14	SB3928001	1	线架组件 2DR	COTTON STAND ASSY 2DR	
15	S51283001	2	垫圈	SPOOL STAND BASE	
16	SB4114001	2	线盘软垫	SPOOL MAT	
17	S51282101	2	线轴缓冲架	SPOOL CUSHION	
18	150179023	2	线轴 B	SPOOL SHAFT B	
19	SB4117001	2	弹簧垫圈 2-5	WASHER SPRING 2-5	
20	SB4119001	2	螺母 M5	NUT 2 M5	
21	SA6607001	2	过线架 2	SPOOL HOLDER 2	
22	150183000	2	过线管套	THREAD HANGER BASE	
23	142990001	2	过线架上过线管	THREAD BUSH	
24	SA6609001	2	过线架定位	SPOOL HOLDER SUPPORTER	
25	062061603	2	螺钉 M6X16	SCREW PAN M6X16	
26	S02747101	1	弹簧	SPRING	
27	SB3625001	1	螺栓组件	BOLT SQUARE ASSY	
28	SB3626001	4	螺栓 M8X46	BOLT M8X46	
29	SB4243001	4	平垫圈 L8	WASHER PLAIN L 8	
30	028080242	4	弹簧垫圈 2-8	WASHER SPRING 2-8	
31	021080202	4	螺母 M8	NUT 2 M8	
32	S40765001	1	<选购件> 连杆组件	<Option parts> CONNECTING ROD ASSY	
33	021060106	2	螺母 M6	NUT 1 M6	
34	017081606	2	六角螺栓 M8X16	BOLT M8X16	
35	021080106	2	六角螺母 M8	NUT 1 M8	
36	S36119021	2	螺母 M6	NUT 1 M6	
37	S36121021	2	弹簧垫圈 2-6	WASHER SPRING 2-6	

Wa. 警告标签 / Warning labels

警告标签 / Warning labels	零部件名称 / Name of parts	尺寸 / Size(mm)	零部件序号 / Code
	<p>感电标签 36 X 150 Label electrical shock 36 X 150</p>	<p>36 X 150</p>	<p>SA9725-001</p>
	<p>感电标签 25 X 28 Label electrical shock 25 X 28</p>	<p>L=28.4</p>	<p>SA9914-001</p>
	<p>操作注意标签 Label caution</p>	<p>56 X 43</p>	<p>SA9826-001</p>
	<p>警告标记 Injury mark</p>	<p>L=16</p>	<p>SA9957-001</p>
	<p>警告标记 Injury mark</p>	<p>L=25</p>	<p>SA9957-002</p>
	<p>高温标志 High temp label</p>	<p>L=16</p>	<p>SB0827-001</p>
	<p>接地标记 Label, grounding</p>	<p>φ 12</p>	<p>S37060-001</p>

Wa. 警告标签 / Warning labels

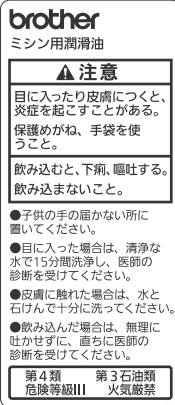
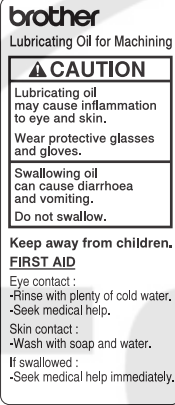
警告标签 / Warning labels	零部件名称 / Name of parts	尺寸 / Size(mm)	零部件序号 / Code
	<p>油壶警告标贴 日文 Oil warning label JP</p>	<p>68 X 30</p>	<p>SB1271-001</p>
	<p>油壶警告标贴 英文 Oil warning label EN</p>	<p>68 X 30</p>	<p>SB1270-001</p>

Ga. 工模具一览表 / Gauge parts list

规格 / Specification	出口国 / Destination	针板 / Needle plate		送布牙 / Feed dog	压脚组件 / Presser foot assy
		记号 / Mark			
-□03	一般出口国, 美洲, 中国 / For General export, the Americas & China	E18	111859301	111860121	153037221
	欧洲 / For Europe	B18 无倒角	145971101	S02742001	S36902001
-□03A	中国 / For China	B18 无倒角	145971101	S02742001	S36902001
-□05	一般出口国, 美洲, 中国 / For General export, the Americas & China	H26	150792101	150793021	150789121
	欧洲 / For Europe	H26	150792101	150793021	S36903001

S-7000DD-Ga



CODE	REF.NO	Page	CODE	REF.NO	Page	CODE	REF.NO	Page	CODE	REF.NO	Page
012060636	B -25	4	062400616	A -13	2	105234003	L -55	24	153132020	D -54	8
	D -32	8		F -6	14	107155001	H -17	18	154593321	L -27	24
	D -37	8		L -7	24	108520001	A -9	2	154594020	L -28	24
	G -11	16		L -44	24	108549001	D -7	8	154595001	L -30	24
	G -18	16		M -4	26	108960002	D -10	8	154596000	L -31	24
	L -26	24		M -6	26	109714020	Z -7	40	155559021	L -46	24
012400536	B -20	4		N -15	28	109763022	C -13	6	156243021	D -85	10
012500536	C -15	6	062400816	L -37	24	110367001	L -32	24		D -86	10
	J -2	20	062401216	F -4	14	110735022	N -24	28	156244020	D -62	10
	J -6	20	062401616	H -13	18	111466121	C -1	6	156948021	D -9	8
	S -15	38	062500616	K -4	22	111859301	B -34+	4	156951021	D -15	8
012501032	S -5	38	062500816	J -11	20		Ga	43	156952021	D -17	8
014680632	D -16	8	062501016	L -42	24	111860121	D -69+	10	156955021	D -18	8
	D -24	8	062501216	A -6	2		Ga	43	156956021	D -19	8
014770632	B -9	4	062501416	L -19	24	114561001	B -37	4	156957120	D -21	8
	D -61	10	062670612	Q -2	34	116922101	J -17	20	156958021	D -23	8
	D -75	10		Q -4	34	117132001	G -25	16	156966121	D -26	8
	G -2	16	062670616	H -5	18		Z -2	40	156969121	D -33	8
	G -4	16	062670712	D -51	8	118735002	D -31	8	158021122	D -25	8
	G -6	16	062671212	A -19	2	118758021	D -80	10	158722021	D -67	10
	G -8	16	062681012	N -14	28	120990001	D -28	8	159324021	G -22+	16
	G -21	16	062681212	D -63	10		D -68	10	180018151	B -36	4
014771032	B -11	4	062681412	D -84	10	140004001	B -16	4	180322021	D -4	8
	B -13	4	062711212	D -77	10	140407021	C -6	6	183388001	G -28	16
	D -5	8	062711412	D -22	8	140553102	B -31	4	183389001	G -29	16
	L -2	24	081004070	H -27	18	140647121	N -7	28	183390001	G -30	16
017081606	Z -34	40	081004870	H -16	18	141728001	C -5	6	200190001	P1 -30	30
021060106	Z -33	40	081006670	H -47	18	142274101	B -28	4		P2 -9	32
021060306	C -25	6	081008070	H -51	18	142403001	C -30	6	A10369001	L -49	24
021080106	Z -35	40	081014670	H -2	18	142708120	G -10	16	BMP3010-0000000-2ST1		
021080202	Z -31	40	0A4300806	S -16	38	142990001	Z -23	40		P2 -1+	32
021400106	P1 -34	30	0A4301206	S -3	38	144458001	D -20	8	BMP3010-0000000-3ST4		
025040236	P1 -33	30	0A4400806	P1 -14	30	144875001	H -30	18		P2 -2+	32
025100132	D -48	8		P1 -15	30	145446021	J -18	20	BMP3010-0000000-4ST4		
025350132	C -11	6		P1 -16	30	145480121	C -22	6		P2 -2+	32
025750132	N -30	28		P1 -21	30	145502021	D -55	8	BMP3010-0000000-AST1		
026040236	N -16	28		R -4	36	145580001	C -12	6		P2 -1+	32
026050136	L -38	24		S -7	38	145737021	H -26	18	S00337021	L -1	24
028080242	Z -30	40	0A4501206	H -57	18	145971101	B -34+	4	S02546402	C -16	6
032461606	P1 -29	30	0A4501606	R -5	36		Ga	43	S02554021	D -8	8
	P2 -8	32		S -10	38	146288021	N -29	28	S02556021	D -35	8
048030342	N -25	28	0A5401605	P1 -32	30	146290021	G -24	16	S02557120	D -40	8
048040342	C -18	6	0A5501206	P1 -18	30		Z -1	40	S02558201	D -3+	8
	N -19	28		P1 -19	30	146293001	P1 -13	30	S02561021	D -45	8
048050142	L -41	24	100022004	P1 -11	30	147504221	D -47	8	S02562021	D -52	8
048060342	B -22	4	100080004	D -70	10	147509021	D -78	10	S02563001	D -53	8
	D -27	8	100328001	D -56	8	148537101	L -13	24	S02573020	D -65	10
	L -33	24	100402004	J -23	20	149097000	N -32	28	S02575020	D -76	10
048070342	D -36	8	100511123	D -82	10	149578020	P1 -6	30	S02578121	D -81	10
048080342	D -49	8	100645003	L -6	24	150179023	Z -18	40	S02600100	F -2	14
048150142	D -59	10		L -10	24	150183000	Z -22	40	S02602021	G -22+	16
	D -73	10	101487000	B -29	4	150384101	C -9	6	S02606020	H -1	18
060350616	J -13	20	102843004	L -4	24	150551020	J -26	20	S02617001	J -12	20
060400516	N -28	28	104449001	A -7	2	150789121	C -7+	6	S02620401	J -24	20
060400616	L -51	24		A -18	2		Ga	43	S02637101	L -3	24
	N -10	28	104450101	A -8	2	150792101	B -34+	4	S02643001	L -5	24
060401216	L -11	24		A -14	2		Ga	43	S02645001	L -12	24
060500616	J -8	20		H -56	18	150793021	D -69+	10	S02648021	L -22	24
060501016	S -12	38	104520020	G -17	16		Ga	43	S02672022	N -17	28
062061016	A -3	2	104525102	J -16+	20	151594001	B -33	4	S02678001	N -22	28
062061603	Z -25	40	104689002	D -79	10	151987022	L -15	24	S02681101	N -27	28
062300616	N -8	28	104821001	H -37	18	153037221	C -7+	6	S02742001	D -69+	10
062301016	N -6	28	105234003	L -16	24		Ga	43		Ga	43

索引 / Index

CODE	REF.NO	Page	CODE	REF.NO	Page	CODE	REF.NO	Page	CODE	REF.NO	Page
S02747101	Z -26	40	SA8145001	B -14	4	SB2314001	D -12	8	SB3563001	L -34	24
S03818101	D -3+	8	SA8152001	C -14	6	SB2315001	S -4	38	SB3564001	L -39	24
S04159000	L -52	24	SA8159001	G -1	16	SB2317001	S -6	38	SB3565001	L -43	24
S04228001	D -83	10	SA8160001	G -3	16	SB2407001	B -8	4	SB3566001	L -45	24
S04632102	J -16+	20	SA8161001	G -5	16		H -38	18	SB3567001	L -47	24
S06573001	G -27	16	SA8162001	G -7	16	SB2408101	Q -5	34	SB3568001	L -35	24
S06594001	G -31	16	SA8167101	H -6	18	SB3247001	S -9	38	SB3569001	L -36	24
S07959001	D -41	8	SA8169001	H -7	18	SB3433001	A -4	2	SB3571101	K -2	22
	F -3	14	SA8178001	J -4	20	SB3434001	A -5	2	SB3572001	J -15+	20
S13385001	C -10	6	SA8186002	D -44	8	SB3435001	A -15	2	SB3574001	J -15+	20
S23651001	B -40	4	SA8189001	N -23	28	SB3436001	A -16	2	SB3575001	M -5	26
S25279101	N -21	28	SA8193001	Q -3	34	SB3437001	A -17	2	SB3576001	M -1	26
S25382001	H -22	18	SA8239201	Z -10	40	SB3440001	A -1	2	SB3584001	P1 -7	30
	H -39	18	SA8436001	B -24	4	SB3441001	A -2	2	SB3585001	P1 -8	30
	H -45	18	SA8903001	G -26	16	SB3442001	A -11	2	SB3586001	P1 -9	30
S25434000	L -29	24	SA8987001	H -48	18	SB3445001	B -1+	4	SB3587001	P1 -10	30
S25452021	N -18	28	SA8989001	H -46	18	SB3446201	B -7	4	SB3588001	P1 -12	30
S25454021	N -20	28	SA8991001	H -52	18	SB3447001	B -2+	4	SB3589001	P1 -20	30
S25456021	N -11	28	SA9523001	B -38	4	SB3449001	B -12	4	SB3595001	J -3	20
S31006002	C -26	6	SA9559001	P1 -35	30	SB3455201	B -27	4	SB3609001	S -2	38
S31014020	D -58	10	SA9564001	P1 -27	30	SB3458001	B -32	4	SB3618001	J -19	20
	D -72	10	SA9565001	P1 -28	30	SB3460001	C -23	6	SB3619001	K -5	22
S31027020	G -32	16	SA9684001	G -16	16	SB3461001	C -21	6	SB3620001	R -2	36
S31952021	C -28	6	SA9716001	L -40	24	SB3463001	C -19	6	SB3621001	R -3	36
S32958000	B -23	4	SA9725001	P1 -23	30	SB3464001	D -66	10	SB3622001	Z -3	40
S33610122	N -9	28		Wa	41	SB3465001	D -1+	8	SB3623101	Z -6	40
S33680001	D -50	8	SA9771001	N -3	28	SB3467001	D -1+	8	SB3625001	Z -27	40
S36119021	Z -36	40	SA9826001	A -20	2	SB3469001	D -11	8	SB3626001	Z -28	40
S36121021	Z -37	40		Wa	41	SB3472001	D -2+	8	SB3627001	Z -4	40
S36902001	C -8+	6	SA9831001	P2 -7	32	SB3475001	D -2+	8	SB3628001	Z -5	40
	Ga	43	SA9854001	J -9	20	SB3477101	D -57	10	SB3629001	Z -9	40
S36903001	C -8+	6	SA9896001	P2 -5	32	SB3478101	D -71	10	SB3652201	S -13	38
	Ga	43	SA9901001	P2 -4	32	SB3480001	E -5	12	SB3655001	S -14	38
S37060001	P1 -22	30	SA9914001	P2 -6	32	SB3483001	J -1	20	SB3769001	B -10	4
	Wa	41		Wa	41	SB3490101	G -9	16	SB3770001	B -3+	4
S37060021	A -21	2	SA9923001	P2 -3	32	SB3491001	G -13	16	SB3771001	B -4+	4
S38769000	H -23	18	SA9945201	G -14	16	SB3493001	G -15	16	SB3775001	B -18	4
S39051001	C -27	6	SA9957001	A -22	2	SB3496001	H -31	18	SB3776001	B -19	4
S40016001	H -19	18		Wa	41	SB3500001	H -4	18	SB3777001	B -3+	4
S40765001	Z -32	40	SA9957002	A -23	2	SB3501001	H -8	18	SB3778001	B -4+	4
S41205001	N -4	28		Wa	41	SB3502001	H -9	18	SB3782001	B -30	4
S41207000	N -31	28	SB0544001	J -10	20	SB3503001	H -11	18	SB3783001	B -5+	4
S43669000	H -28	18	SB0609001	N -5	28	SB3504001	H -12	18	SB3784001	B -5+	4
S46736001	C -17	6	SB0610001	N -13	28	SB3505001	H -18	18	SB3785001	C -2	6
S47264001	D -39	8	SB0611001	N -12	28	SB3507001	H -20	18	SB3786001	C -4	6
	D -43	8	SB0827001	P1 -26	30	SB3508001	H -53	18	SB3787001	D -13	8
S51282101	Z -17	40		S -8	38	SB3509001	H -54	18	SB3788001	D -14	8
S51283001	Z -15	40		Wa	41	SB3511001	H -25	18	SB3789001	D -29	8
S52164000	P1 -31	30	SB1270001	Z -11	40	SB3512001	H -24	18	SB3790001	D -30	8
S52764001	H -33	18		Wa	42	SB3514001	H -29	18	SB3791001	D -34	8
	H -36	18	SB1271001	Z -12	40	SB3515001	H -41	18	SB3792001	D -38	8
S59890001	N -26	28		Wa	42	SB3517001	H -43	18		D -42	8
SA1229101	J -25	20	SB1305001	G -23+	16	SB3522001	H -34	18	SB3793001	D -46	8
SA1303101	H -50	18	SB1600001	J -22	20	SB3523001	H -35	18	SB3794001	D -64	10
SA1345001	J -7	20	SB1603001	E -2	12	SB3524001	H -3	18	SB3796001	G -19	16
SA1360101	K -3	22	SB1604001	E -3	12	SB3526101	H -44	18	SB3797001	G -20	16
SA1388101	L -48	24	SB1605001	E -4	12	SB3529101	K -1	22	SB3798001	J -14	20
SA2161001	B -21	4	SB1607001	E -6	12	SB3530001	J -5	20	SB3799001	L -9	24
SA2422001	B -17	4	SB1609001	E -7	12	SB3554201	H -40	18	SB3802001	L -21	24
SA4494001	D -6	8	SB1610001	E -8	12	SB3556001	L -8	24	SB3803001	L -23	24
SA6607001	Z -21	40	SB1611001	E -9	12	SB3557001	L -14	24	SB3804001	L -53	24
SA6609001	Z -24	40	SB1677001	G -23+	16	SB3558001	L -17	24	SB3805001	L -54	24
SA7285101	L -18	24	SB2267002	C -3	6	SB3559001	L -20	24	SB3816101	P1 -17+	30

CODE	REF.NO	Page	CODE	REF.NO	Page	CODE	REF.NO	Page	CODE	REF.NO	Page
SB3817201	P1 - 17+	30									
SB3834001	R - 1	36									
SB3850001	A - 12	2									
SB3851201	B - 26	4									
SB3852001	L - 24	24									
SB3853001	L - 25	24									
SB3854001	E - 1	12									
SB3856001	G - 12	16									
SB3857001	H - 10	18									
SB3870001	D - 60	10									
	D - 74	10									
SB3872001	P1 - 24	30									
SB3876001	Z - 13	40									
SB3877001	M - 2	26									
SB3878001	C - 20	6									
SB3912001	B - 6+	4									
SB3913001	B - 6+	4									
SB3928001	Z - 14	40									
SB3977001	B - 39	4									
SB3985001	H - 32	18									
SB3986001	A - 10	2									
SB3992001	H - 21	18									
SB3993001	F - 5	14									
SB3999101	M - 3	26									
SB4015001	H - 14	18									
SB4016001	C - 24	6									
SB4018101	Z - 8	40									
SB4022001	F - 1	14									
SB4037001	H - 55	18									
SB4038001	J - 21	20									
SB4039001	B - 2+	4									
SB4074001	B - 1+	4									
SB4084001	B - 6+	4									
SB4086001	Q - 1	34									
SB4114001	Z - 16	40									
SB4117001	Z - 19	40									
SB4119001	Z - 20	40									
SB4154001	S - 11	38									
SB4155001	P1 - 25	30									
SB4190001	B - 35	4									
SB4201001	N - 2	28									
SB4216001	J - 20	20									
SB4243001	Z - 29	40									
SB4285001	C - 29	6									
SB4310001	N - 1	28									
SB4311001	S - 1	38									
SB4447101	H - 42	18									
	H - 49	18									
SB4448101	H - 58	18									
SB4490001	L - 50	24									
SB4492001	B - 15	4									
SB4527101	H - 15	18									
SB4580001	P1 - 1	30									
SB4581001	P1 - 2	30									
SB4582001	P1 - 3	30									
SB4583001	P1 - 4	30									
SB4584001	P1 - 5+	30									
SB4585001	P1 - 5+	30									
SB4587101	P1 - 17+	30									

brother®

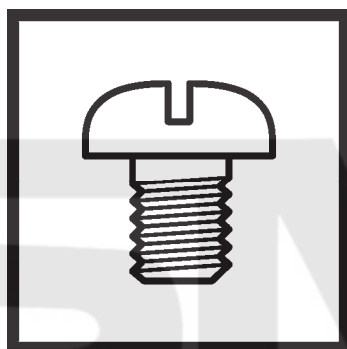

零件手册
PARTS BOOK

BROTHER INDUSTRIES, LTD. <http://www.brother.com/>
1-5, Kitajizoyama, Noda-cho, Kariya 448-0803, Japan. Phone : 81-566-95-0088

© 2013 Brother Industries, Ltd. All Rights Reserved.

S-7000DD
SB4302-001.C/E
2013.05.B (1)