

RH-981A

パーツブック
PARTS BOOK

電子鳩目穴かがりミシン

ELECTRONIC EYELET BUTTON HOLDER

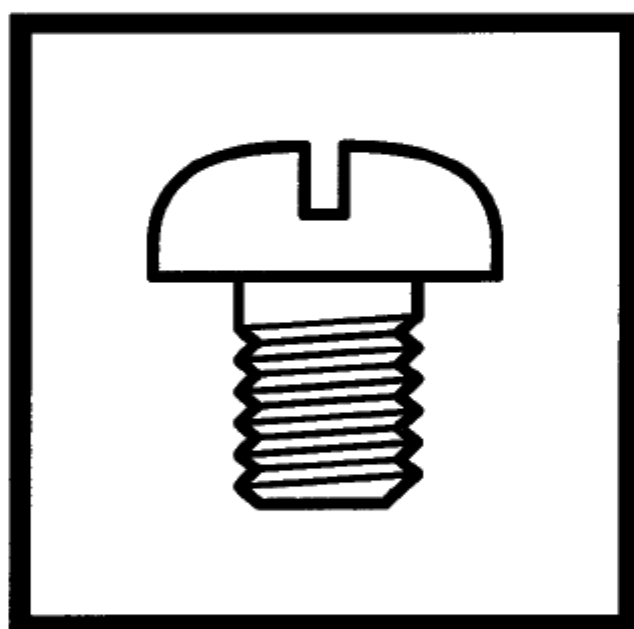

brother®

BROTHER INDUSTRIES, LTD.

• RH-981A-XXXX •

MADE IN JAPAN

00 : 紳士服、婦人服 / Men's clothes and ladies' clothes

01 : 紳士服、婦人服 / Men's clothes and ladies' clothes

02 : ジーンズ、ワーキング / Jeans and work clothes

52 : ジーンズ、ワーキング / Jeans and work clothes

パーツブックご利用に際して

1. この本は、2002年5月のデータに基づいて作成されたものです。
2. 部品は予告なしに設計変更される場合があります。
3. 組単位で補給する部品は、 破線で示しております。
4. 部品コード欄が*となっている場合は、仕様別部品一覧表(P89～P93)でお調べください。

目 次

A.	主体関係	1	S.	上糸切り関係.....	47
B.	針棒・天秤関係	5	T	針位置検出器関係.....	47
C.	上軸関係	9	U1.	コントロールボックス関係	49
D.	針振関係	9	U2.	コントロールボックス関係	53
E.	針棒揺動関係	11	V1.	空圧関係.....	57
F1.	押エ関係	13	V2.	空圧関係.....	61
F2.	押エ関係	15	W.	電装品関係	65
F3.	押エ関係 (ジーンズ仕様)	17	X.	布制御関係.....	67
G.	送り関係	21	Y.	踏板関係.....	71
H.	カッター関係	25	AA1.	付属装置関係.....	73
J.	テンションプリー関係	27	AA2.	付属装置関係.....	77
K.	下軸関係	27	AA3.	付属装置関係.....	79
L1.	二重環ルーバ関係.....	29	AA4.	付属装置関係.....	83
L2.	二重環ルーバ関係.....	33	Z.	付属品関係	85
M.	ルーバ関係.....	35	Sp1.	仕様別部品一覧表	89
N.	スプレダー関係.....	35	Sp2.	仕様別部品一覧表	91
P.	給油潤滑関係	37	Sp3.	仕様別部品一覧表	92
Q.	糸通シ関係	39	Sp4.	仕様別部品一覧表	93
R1.	糸切り関係.....	43	Wa.	警告ラベル	94
R2.	糸切り関係 (ジーンズ仕様)	45			

Notes for using this parts book

1. This book was prepared based on information available in May 2002.
2. Parts are subject to changes in design without prior notice.
3. Parts supplied as complete assemblies are circled by a dotted line [].
4. If the symbol * is found in the " Parts No." column, refer to the different parts lists, gauge parts list on page 89-93.

CONTENTS

A.	Machine body.....	1	S.	Upper thread trimmer mechanism.....	47
B.	Needle bar and thread take-up mechanism	5	T	Synchronizer.....	47
C.	Upper shaft mechanism.....	9	U1.	Control box mechanism.....	49
D.	Zigzag mechanism.....	9	U2.	Control box mechanism.....	53
E.	Needle bar rocking mechanism.....	11	V1.	Air pressure mechanism.....	57
F1.	Presser foot mechanism.....	13	V2.	Air pressure mechanism.....	61
F2.	Presser foot mechanism.....	15	W.	Power supply equipment mechanism...	65
F3.	Presser foot mechanism (Jeans spec.).....	17	X.	Cloth control system mechanism.....	67
G.	Feed mechanism.....	21	Y.	Foot switch pedal mechanism.....	71
H.	Cutter mechanism.....	25	AA1.	Attachment set.....	73
J.	Tension pulley mechanism.....	27	AA2.	Attachment set.....	77
K.	Lower shaft mechanism.....	27	AA3.	Attachment set.....	79
L1.	Double chain stitch looper mechanism.....	29	AA4.	Attachment set.....	83
L2.	Double chain stitch looper mechanism.....	33	Z.	Accessories.....	85
M.	Looper mechanism.....	35	Sp1.	Different parts list.....	89
N.	Double chain stitch looper mechanism.....	35	Sp2.	Different parts list.....	91
P.	Lubrication.....	37	Sp3.	Different parts list.....	92
Q.	Threading mechanism.....	39	Sp4.	Different parts list.....	93
R1.	Thread trimmer mechanism.....	43	Wa.	Index	94
R2.	Thread trimmer mechanism (Jeans spec.)..	45			

A. 主体関係 / Machine body

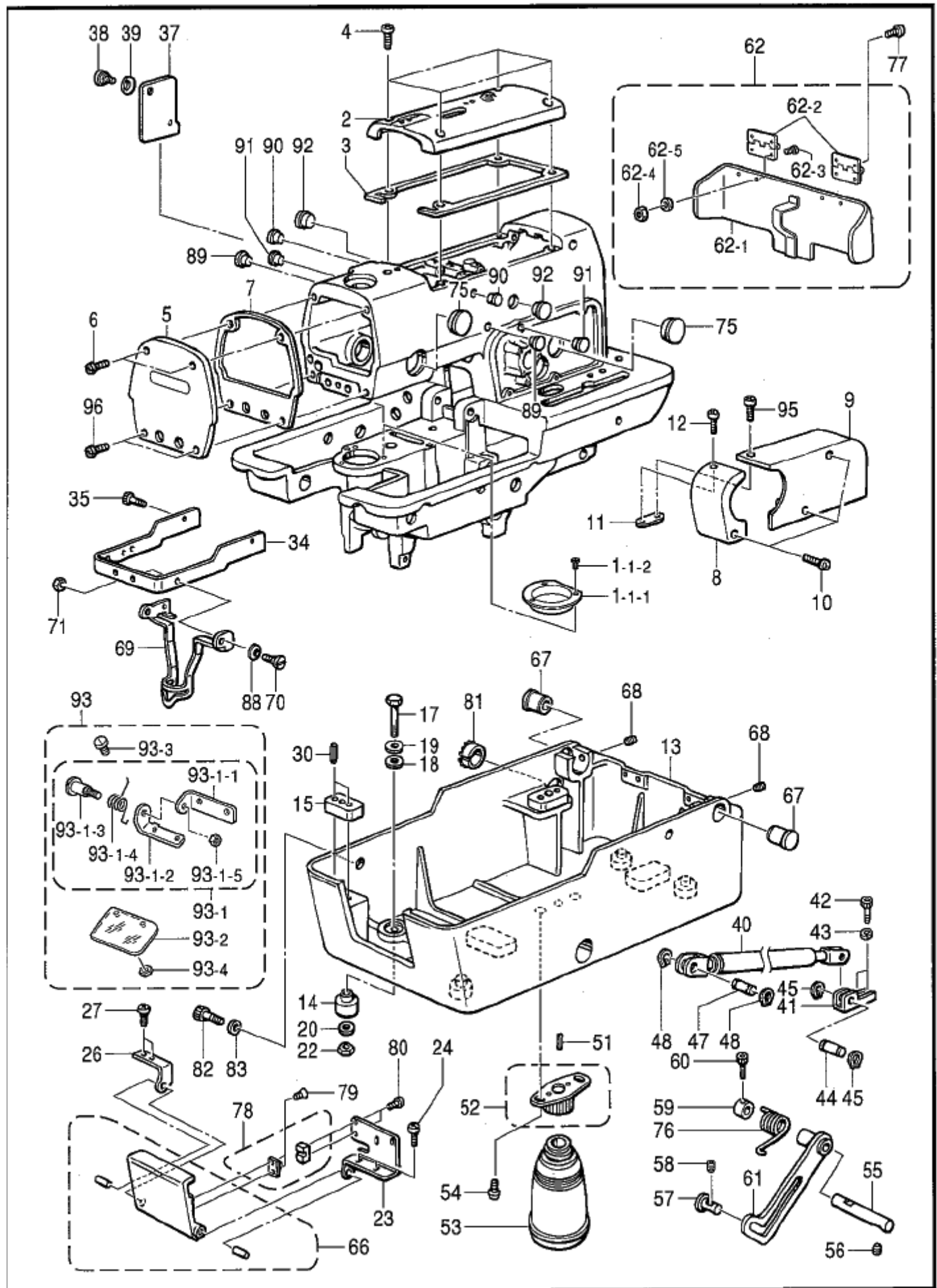

A. 主体関係 / Machine body

REF.NO	CODE	QTY	ヒンメイ	NAME OF PARTS	RM
1-1-1	S51215001	1	レスト ^タ イタル	BUSH, LOOPER BASE	
1-1-2	S23616101	3	シメネジ ^{4X10}	SCREW, M4X10	
2	S35232009	1	ウツタ	TOP COVER	
3	S35231000	1	ウツタハ ^{ツキン}	PACKING, ;TOP COVER	
4	062501202	4	ナ ^ハ コM5X12	SCREW, PAN M5X12	
5	S35230009	1	メンタ	FACE PLATE	
6	062500804	2	ナ ^ハ コ5X8	SCREW, PAN M5X8	
7	S35229000	1	メンタハ ^{ツキン}	PACKING, ;FACE PLATE	
8	S35227009	1	ベルトカバー ^{-F}	BELT COVER, F	
9	S35228009	1	ベルトカバー ^{-R}	BELT COVER, R	
10	062501202	3	ナ ^ハ コM5X12	SCREW, PAN M5X12	
11	S35226001	1	ベルトカバー ^{-サエ}	BELT COVER SUPPORT	
12	062400812	1	ナ ^ハ コ4X8	SCREW, PAN M4X8	
13	S34956209	1	ベッド ^{タイ}	BED BASE	
14	158827009	4	ベッド ^{クッションA}	BED BASE CUSHION, A	
15	S35225000	4	ベッド ^{クッション}	BED BASE CUSHION	
17	S21728001	4	ボルト ^{6X80}	BOLT, M6X80	
18	159458009	4	ゴムシート	RUBBER SHEET	
19	115947001	4	ワッシャ ^ネ	WASHER, PLAIN 6.35	
20	025060332	4	ワッシャ ^ネ 16	WASHER, PLAIN L 6	
22	021060102	4	ナット ^{1.6}	NUT, 1 M6	
23	S35203001	1	カバー ^{-サエ}	COVER SUPPORT PLATE, R	
24	062400812	2	ナ ^ハ コ4X8	SCREW, PAN M4X8	
26	S35224001	1	カバー ^{-サエ}	COVER SUPPORT PLATE, L	
27	062400812	2	ナ ^ハ コ4X8	SCREW, PAN M4X8	
30	047502242	8	スプリング ^{ピンAW5}	PIN, SPRING ROLL AW5	
34	S35223101	1	カバー ^{ウカ}	COVER	
35	018400832	4	ボルト ^{4X8}	BOLT, SOCKET M4X8	
37	S35222001	1	カバー ^窓	COVER, ;Z-WINDOW	
38	S35221001	1	ダンネジ ^{M4}	SHOULDER SCREW, M4	
39	107017002	1	ワッシャ ^ネ	WASHER, WAVE SPRING 6.45	
40	S35201000	1	GSスプリング	GS-SPRING	
41	S35220101	1	GSサポーター	SUPPORT PLATE, ;GS	
42	018501222	2	ボルト ^{5X12}	BOLT, SOCKET M5X12	
43	028050242	2	ワッシャ ^ネ 2-5	WASHER, SPRING 2-5	
44	S35219001	1	GSサポーター	SUPPORT PIN, R ;GS	
45	048080142	2	リテーニング ^{リングC8}	RETAINING RING, C8	
47	S35218001	1	GSサポーター	SUPPORT PIN, F ;GS	
48	048080142	2	リテーニング ^{リングC8}	RETAINING RING, C8	
51	047502242	1	スプリング ^{ピンAW5}	PIN, SPRING ROLL AW5	
52	154465001	1	ハイキヤツフ ^{サエ}	DUST OILER SUPPORT ASSY	
53	114486002	1	オイル ^{タイ}	OILER	
54	062500812	2	ナ ^ハ コ5X8	SCREW, PAN M5X8	
55	S35217001	1	ピン ^{レバ} -サエ ^ク	SUPPORT SHAFT, ;H-LEVER	
56	014060632	1	セット ^ネ 6X6	SET SCREW, SOCKET (CP) M6X6	
57	S35216001	1	ピン ^{レバ} -サエ ^ク	SHAFT, ;H-LEVER	
58	014060632	1	セット ^ネ 6X6	SET SCREW, SOCKET (CP) M6X6	
59	S35215001	1	セット ^ネ	SET SCREW COLLAR	
60	018061236	1	ボルト ^{6X12}	BOLT, SOCKET M6X12	
61	S17965001	1	ヘッド ^{サポーター}	HEAD SUPPORT LEVER	
62	S46496009	1	ベッド ^{カバー} -クミ	BED BASE COVER ASSY	
62-1	S46497009	1	ベッド ^{カバー}	BED BASE COVER	
62-2	S44204000	2	スプリング ^{ジョイント}	HINGE, SPRING	
62-3	062300616	4	ナ ^ハ コM3X6	SCREW, PAN M3X6	
62-4	021300206	4	ナット ²	NUT, 2 M3	
62-5	025030232	4	ワッシャ ^ネ 3	WASHER, PLAIN M 3	
66	S35211009	1	フロント ^{カバー} -クミ	FRONT COVER ASSY	
67	S35207001	2	ピン ^B	HINGE, B	
68	014060632	2	セット ^ネ 6X6	SET SCREW, SOCKET (CP) M6X6	
69	S35206201	1	フィン ^{ガード}	FINGER GUARD	
70	S35221001	2	ダンネジ ^{M4}	SHOULDER SCREW, M4	

A. 主体関係 / Machine body

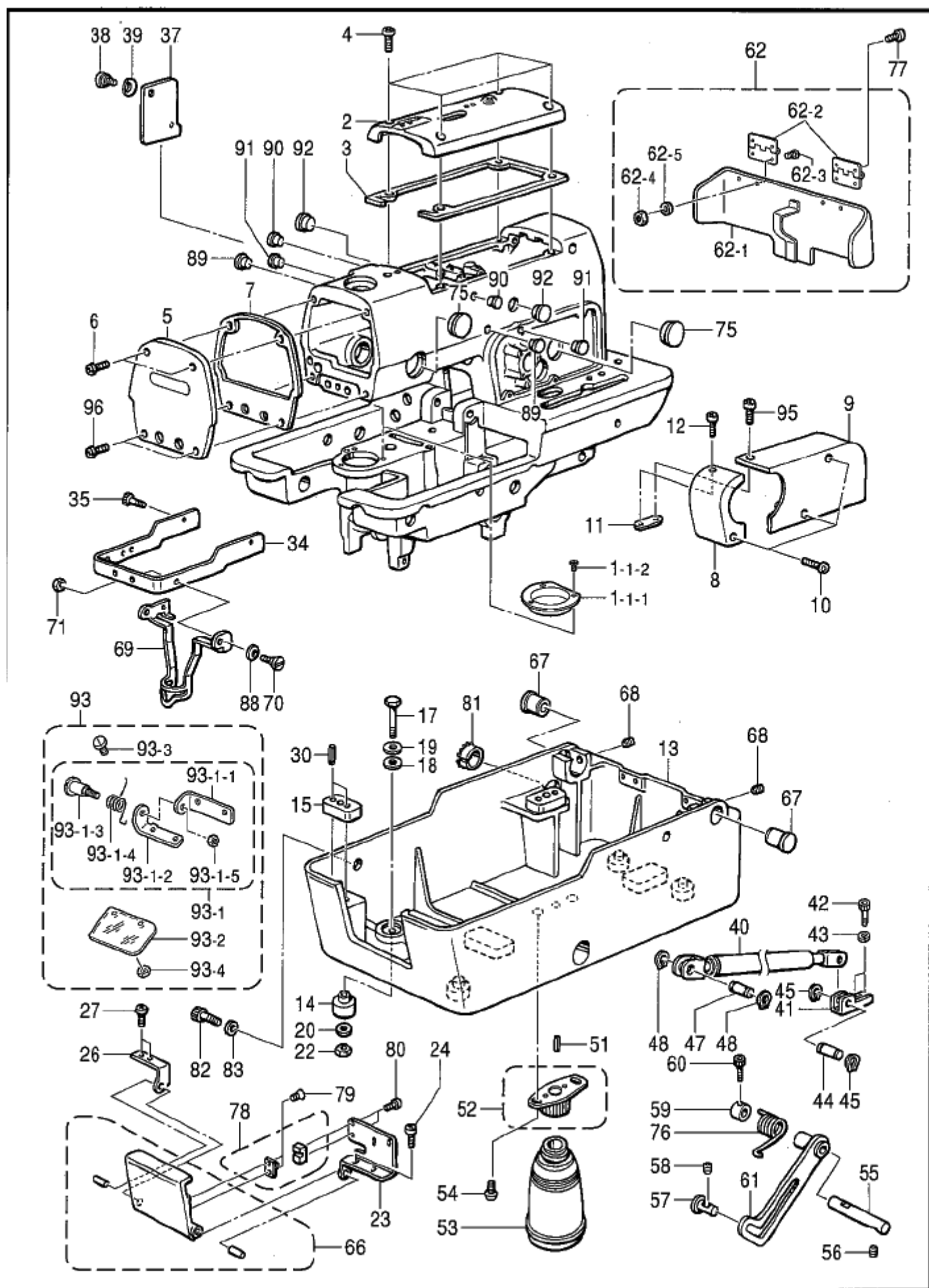

A . 主体関係 / Machine body

REF.NO	CODE	Q'TY	ヒンメイ	NAME OF PARTS	RM
71	021400202	2	2ｼﾞﾅﾌﾞﾄ4	NUT, 2 M4	
75	150607000	2	ｺﾞﾑｾﾝ32.8	RUBBER CAP, 32.8	
76	S35204001	1	ﾊﾞｯﾄﾞﾋﾝｼﾞﾊﾞﾈ	SPRING	
77	062300512	4	ﾊﾟﾆｰｺ3X5	SCREW, PAN M3X5	
78	S33899000	1	ﾎｰﾙｷｯﾂｸﾞﾙﾐ	BALL CATCH ASSY	
79	004300513	2	ﾌﾗｯﾄｺ3X5	SCREW, FLAT M3X5	
80	062300616	2	ﾊﾟﾆｰｺM3X6	SCREW, PAN M3X6	
81	S35202000	1	ｼﾞｻﾞｲﾌﾞｯｼﾞ	BUSH, ;UNIVERSAL	
82	018082036	1	ｱｯﾊﾞﾙﾄ8X20	BOLT, SOCKET M8X20	
83	025080132	1	ﾋﾗｻﾞｶﾞﾈｼヨｳ8	WASHER, PLAIN S 8	
88	107017002	2	ﾅﾐﾊﾞﾈｻﾞｶﾞﾈ	WASHER, WAVE SPRING 6.45	
89	117936001	1	ｺﾞﾑｾﾝ9.4	RUBBER CAP, 9.4	
90	158437001	2	ｺﾞﾑｾﾝ10	RUBBER CAP, 10	
91	S32264001	2	ｺﾞﾑｾﾝ11.5	RUBBER CAP, 11.5	
92	150756000	2	ｺﾞﾑｾﾝ18.5	RUBBER CAP, 18.5	
93	S37084001	1	ｱｲｶﾞｰﾄﾞｸﾞﾙﾐ	EYE GUARD ASSY	
93-1	S37085001	1	ｱｲｶﾞｰﾄﾞﾄﾘｯﾌﾟｲﾀｸﾞﾙﾐ	SETTING PLATE ASSY, ;E-GUIDE	
93-1-1	S37086001	1	ｱｲｶﾞｰﾄﾞﾄﾞﾀﾞｲ	EYE GUARD BRACKET	
93-1-2	S34844001	1	ｱｲｶﾞｰﾄﾞﾄﾘｯﾌﾟｲﾀ	SETTING PLATE, ;E-GUARD	
93-1-3	S36071001	1	ｱｲｶﾞｰﾄﾞｼﾞｬﾝﾈｼﾞ	SCREW	
93-1-4	S36070001	1	ｱｲｶﾞｰﾄﾞﾄﾞﾄﾞｼﾊﾞﾈ	SPRING, ;EYE GUARD	
93-1-5	106129002	1	ﾅｯﾄ3.57	NUT, SM3.57	
93-2	153098000	1	ｱｲｶﾞｰﾄﾞ	EYE GUARD	
93-3	100257010	2	ｼﾞﾒﾈｼﾞ3.57	SCREW, SM3.57X6	
93-4	106129002	2	ﾅｯﾄ3.57	NUT, SM3.57	
95	062400812	1	ﾊﾟﾆｰｺ4X8	SCREW, PAN M4X8	
96	062500804	2	ﾊﾟﾆｰｺ5X8	SCREW, PAN M5X8	

B. 針棒・天桿關係 / Needle bar and thread take-up mechanism

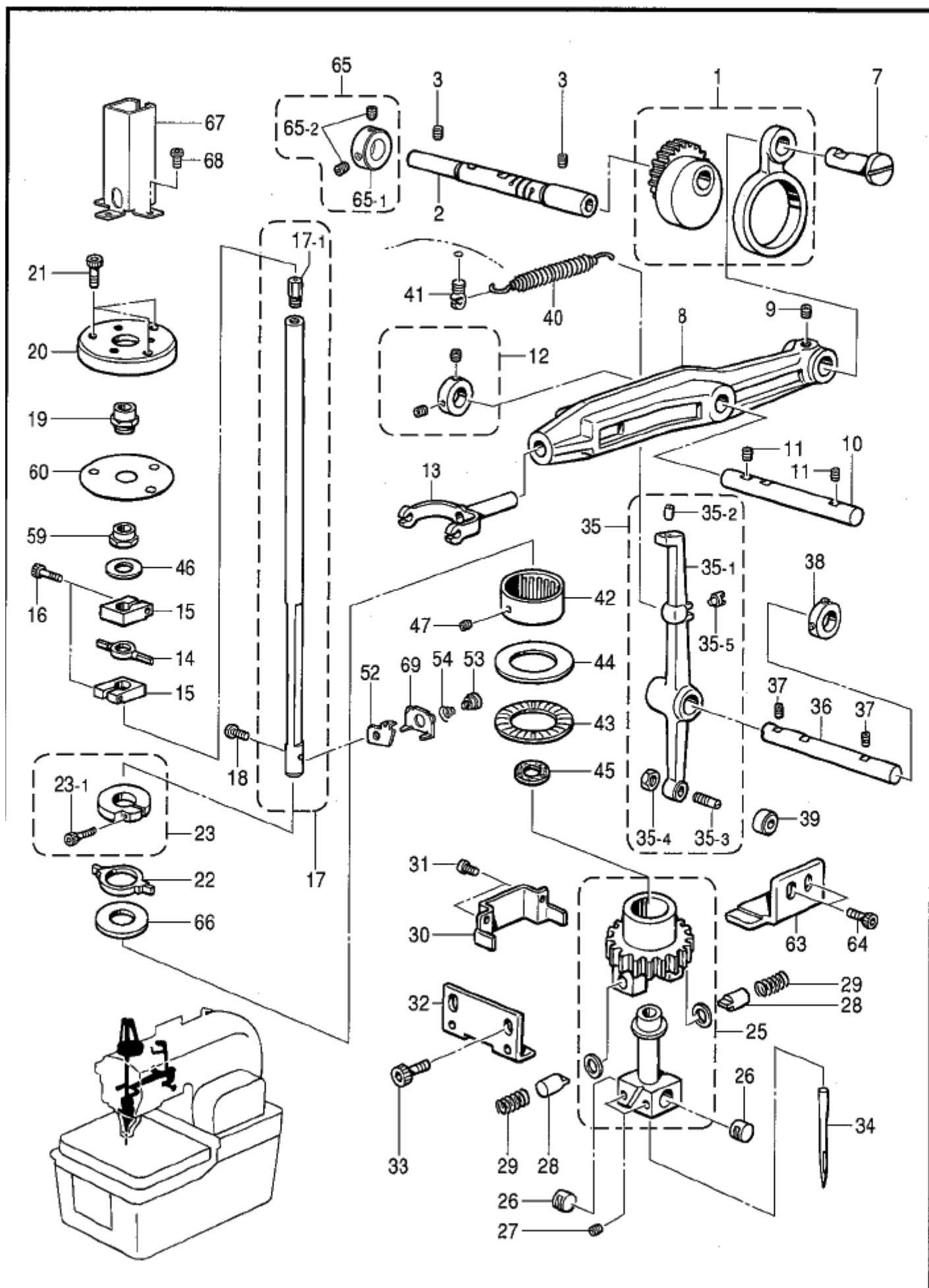

B. 針棒・天秤関係 / Needle bar and thread take-up mechanism

REF.NO	CODE	QTY	ヒンメイ	NAME OF PARTS	RM
1	S35346101	1	外`ウツト`クミ	DRIVING ROD ASSY	
2	S35339101	1	外`ウツト`ウキ`ヤシ`ク	SHAFT, ;D-GEAR	
3	014060632	2	ア`ナクホ`ミ6X6	SET SCREW, SOCKET (CP) M6X6	
7	S35340001	1	外`ウツト`ピン	PIN	
8	S35337101	1	外`ウツト`ウレバ`クミ	N-BAR DRIVING LEVER ASSY	
9	014060632	1	ア`ナクホ`ミ6X6	SET SCREW, SOCKET (CP) M6X6	
10	S35338001	1	外`ウツト`ウレバ`シ`ク	SHAFT, ;D-LEVER	
11	014060632	2	ア`ナクホ`ミ6X6	SET SCREW, SOCKET (CP) M6X6	
12	S35335001	1	セツト`カネ`クミ	SET SCREW COLLAR ASSY	
13	S35334001	1	外`ウツト`ヨコ`ク	NEEDLE BAR YOKE	
14	S35333001	1	外`ウツト`ウスイ`ハイリンク	LEVEL FEED LINK, ;N-BAR	
15	S35332001	2	外`ウツト`ウタ`キ	NEEDLE BAR CLAMP	
16	018301236	2	ア`ナクホ`ボルト`3X12	BOLT, SOCKET M3X12	
17	S35331101	1	外`ウツト`ウキ`クミ	NEEDLE BAR ASSY	
17-1	S35150001	1	外`ウツト`ウキ`クミ	NEEDLE BAR YARN FEEDER	
18	140553102	1	ア`タマツキ`ボルト`メネジ`3.18	SET SCREW, SM3.18	
19	S35148001	1	外`ウツト`ウメタ`ル	BUSH, U ;N-BAR	
20	S51195001	1	外`ウツト`ウメタ`ル`ボサ`イ`B	HOLDER BASE, B ;N-BUSH	
21	018402032	3	ア`ナクホ`ボルト`4X20	BOLT, SOCKET M4X20	
22	S35144001	1	外`ウツト`ウスイ`ハイリンク	LEVEL FEED LINK, ;N-BAR	
23	S37432001	1	外`ウツト`ウツク`タ`キ`クミ	BLOCK CLAMP ASSY, ;N-BAR	
23-1	018301632	1	ア`ナクホ`ボルト`3X16	BOLT, SOCKET M3X16	
25	S35142001	1	外`ウツト`ウツク`タ`キ`クミ	NEEDLE BAR BLOCK ASSY	
26	S35138001	2	外`ウツト`ウツク`タ`キ`クミ	GUIDE COLLAR, ;N-BAR	
27	153675001	2	ア`ナクホ`ボルト`4.37	SET SCREW, SOCKET SM4.37	
28	S35137001	2	外`ウツト`ウツク`タ`キ`クミ	GUIDE, ;N-BAR	
29	S35136001	2	外`ウツト`ウツク`タ`キ`クミ	SPRING	
30	S35135001	1	外`ウツト`ウツク`タ`キ`クミ	SUPPORT PLATE, ;N-BAR GUIDE	
31	062300616	2	外`ウツト`ウツク`タ`キ`クミ	SCREW, PAN M3X6	
32	S35134001	1	外`ウツト`ウツク`タ`キ`クミ	SUPPORT, A ;GEAR	
33	018501036	2	ア`ナクホ`ボルト`5X10	BOLT, SOCKET M5X10	
34	S35133016	1	<-00, 上糸切り用> ミシン`ハリ`DOX558`...`<#16>	<For-00,Upper thread trimmer> NEEDLE, DOX558 (#16)	
34	S35133014	1	<-01, 上下糸切り用> ミシン`ハリ`DOX558`...`<#14>	<For-01,Upper & lower thread trimmer> NEEDLE, DOX558 (#14)	
34	S35133018	1	<-02, ジーンズ仕様> ミシン`ハリ`DOX558`...`<#18>	<For-02, jeans specification> NEEDLE, DOX558 (#18)	
35	S35132101	1	テン`ビ`ン`クミ	THREAD TAKE-UP LEVER ASSY	
35-1	S35131001	1	テン`ビ`ン`クミ	THREAD TAKE-UP LEVER	
35-2	S35130001	1	テン`ビ`ン`クミ	THREAD GUIDE	
35-3	S35129001	1	テン`ビ`ン`カム`コ`シ`ク	ROLLER SHAFT	
35-4	021500303	1	ナツト`3`M5	NUT, 3 M5	
35-5	S35911101	1	テン`ビ`ン`クミ	SPRING BASE	
36	S35128001	1	テン`ビ`ン`クミ	SUPPORT SHAFT	
37	014060632	2	ア`ナクホ`ミ6X6	SET SCREW, SOCKET (CP) M6X6	
38	S23612051	1	セツト`カネ`クミ	SET SCREW COLLAR ASSY	
39	S35127001	1	テン`ビ`ン`カム`コ`シ`ク	CAM ROLLER, ;T/TAKE-UP	
40	S35126001	1	テン`ビ`ン`クミ	SPRING	
41	S35078001	1	ハ`ネ`カ`ク	SPRING HOOK	
42	S35125000	1	シ`ク`ウ`タ`25/20	BEARING, 25/20	
43	S35124000	1	スラスト`ハ`ア`リ`ン`ク	BEARING, ;THRUST	
44	S35123000	1	スラスト`ワ`シ`ヤ`	WASHER, ;THRUST	
45	S35122000	1	外`ウツト`ウツク`タ`キ`クミ	FELT	
46	S35121000	1	外`ウツト`ウツク`タ`キ`クミ	FELT, ;N-BAR	
47	148294001	1	ア`ナクホ`ボルト`3.57`クミ`ミ	SET SCREW, SOCKET (CP) SM3.57	
52	S41310001	1	外`ウツト`ウツク`タ`キ`クミ	GUIDE, A	
53	141514002	1	ハ`サ`ミ`タ`ン`ネ`ジ`	SHOULDER SCREW	

B. 針棒・天秤關係 / Needle bar and thread take-up mechanism

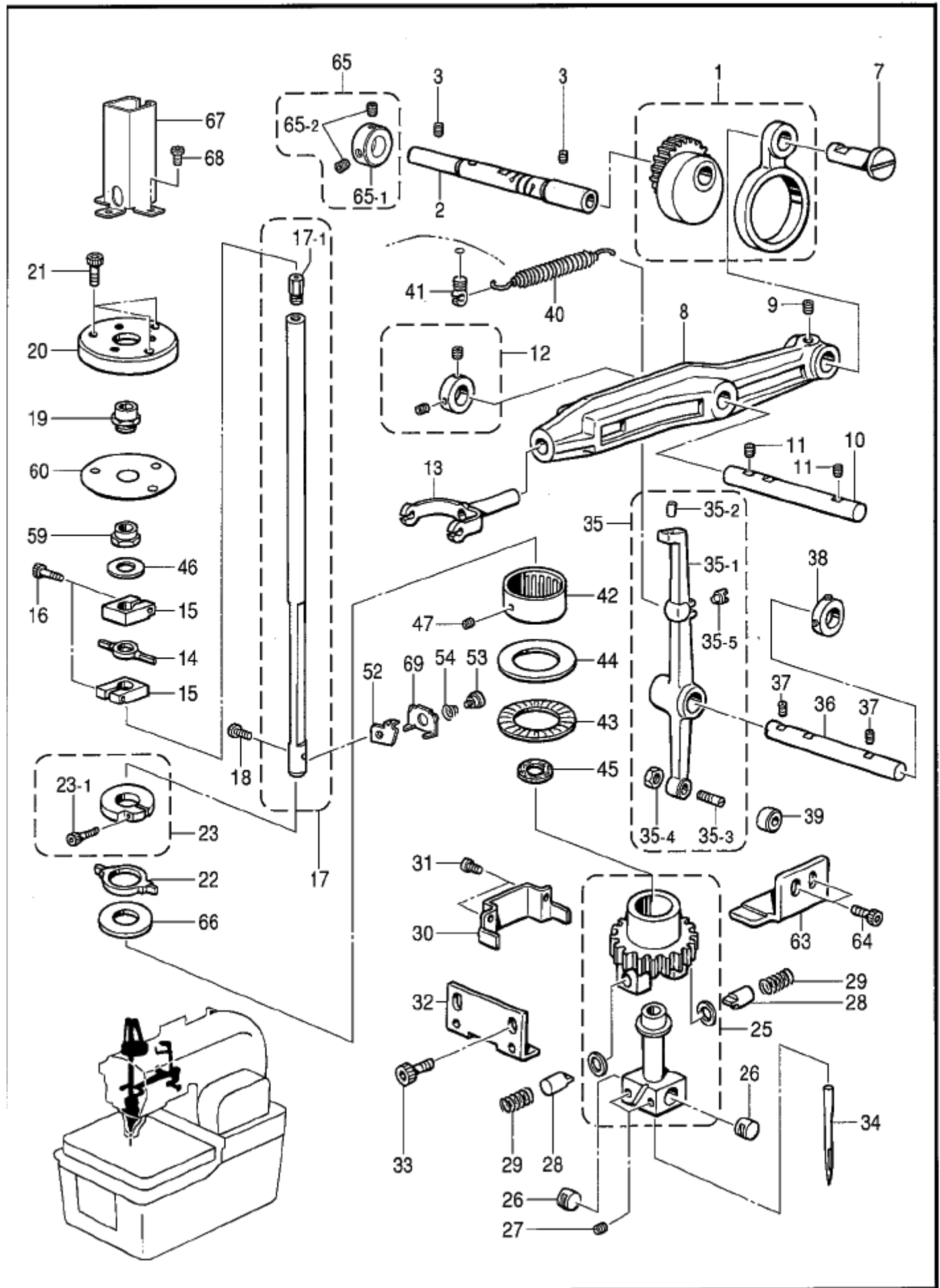

B . 針棒・天秤関係 / Needle bar and thread take-up mechanism

REF.NO	CODE	QTY	ヒンメイ	NAME OF PARTS	RM
54	S35118001	1	ハリトチヨウシハネ	TENSION SPRING	
59	S35117001	1	ハリホケメタルナツト	NUT, U ;N-B/BUSH	
60	S35116001	1	ハリホケメタルイタハネ	SPRING, PLATE	
63	S35114001	1	ハリホケキヤサIB	SUPPORT, B ;GEAR	
64	018400832	2	アナホルト4X8	BOLT, SOCKET M4X8	
65-1	S17608009	1	セツトカラー	SET SCREW COLLAR	
65-2	014060632	2	アナホクミ6X6	SET SCREW, SOCKET (CP) M6X6	
66	S35113001	1	ハリホケウフロックカラー	COLLAR, ;N-BAR BLOCK	
67	S51194001	1	ハリホケガード	NEEDLE BAR GUARD	
68	018400632	3	アナホルト4X6	BOLT, SOCKET M4X6	
69	S41251001	1	ハリトサエイタ	HOLDER PLATE, A ;N-THREAD	

C. 上軸關係 / Upper shaft mechanism

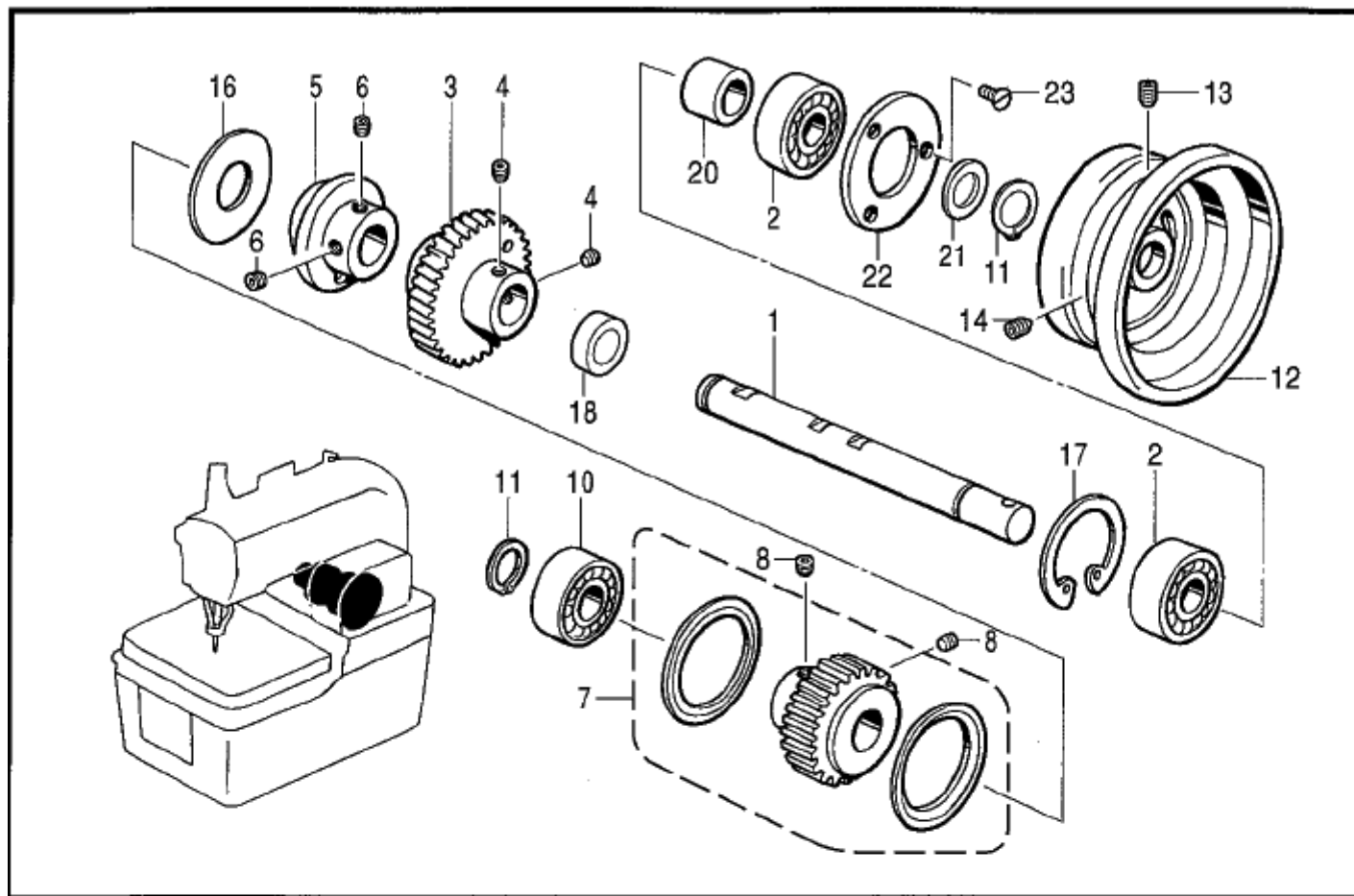

118-981-109

D. 針振關係 / Zigzag mechanism

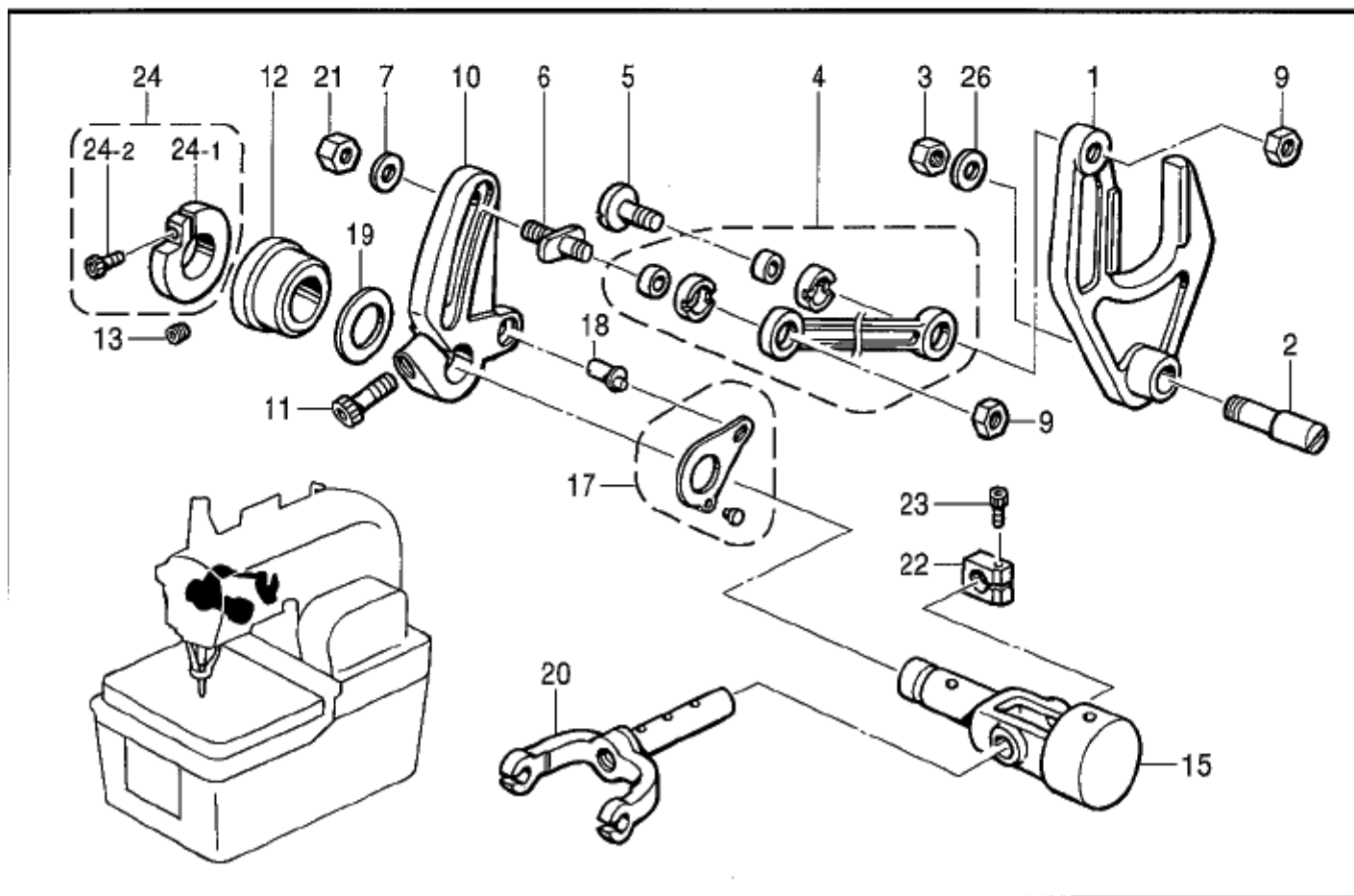

118-981-110

C . 上軸関係 / Upper shaft mechanism

REF.NO	CODE	Q'TY	ヒンメイ	NAME OF PARTS	RM
1	S43710001	1	ウツシク	UPPER SHAFT	
2	072620260	2	タマシクウケ6202VVC2	BALL BEARING, 6202VVC2	
3	S35247001	1	ハリホウキヤ	GEAR, ;N-BAR	
4	S23651001	2	アナヒラ6X6ホノメ	SET SCREW, SOCKET (FT) M6X6	
5	S35246001	1	ハリフリカム	ZIGZAG CAM	
6	S23651001	2	アナヒラ6X6ホノメ	SET SCREW, SOCKET (FT) M6X6	
7	S35245001	1	ウツシクTフーリクミ	TENSION PULLEY ASSY, ;U-SHAFT	
8	S23651001	2	アナヒラ6X6ホノメ	SET SCREW, SOCKET (FT) M6X6	
10	076002450	1	タマシクウケ6002DD	BALL BEARING, 6002DD	
11	048150142	2	トメワシクヨウC15	RETAINING RING, EXTERNAL C15	
12	S43708009	1	フーリクミ	PULLEY ASSY	
13	014060632	1	アナホミ6X6	SET SCREW, SOCKET (CP) M6X6	
14	016061031	1	アナホリ 6X10	SET SCREW, SOCKET (CN) M6X10	
16	S35249001	1	スラストサカネ	WASHER, ;THRUST	
17	048350242	1	トメワシクヨウC35	RETAINING RING, INTERNAL C35	
18	S43711000	1	ウツシクカラー	COLLAR, ;U-SHAFT	
20	151998000	1	ヘアリングカサ	BEARING COLLAR	
21	116920001	1	オクリシクスラストリング	RING, THRUST	
22	141276001	1	タマシクウケフタS	BALL BEARING CAP, S	
23	102843004	3	サラネシ 3.57	SCREW, FLAT SM3.57	

118-981-109

D . 針振り関係 / Zigzag mechanism

REF.NO	CODE	Q'TY	ヒンメイ	NAME OF PARTS	RM
1	S35264001	1	ハリフリフタマタ	ZIGZAG FORK	
2	S35263101	1	ハリフリフタマタササエピン	SUPPORT PIN, ;Z-FORK	
3	021080306	1	ナツト3シユ8	NUT, 3 M8	
4	S35262001	1	ハリフリレンカクミ	CONNECTING ROD ASSY, ;ZIGZAG	
5	S35260001	1	タンネシ M6	SHOULDER SCREW, M6	
6	S35259001	1	ハリフリクランクタンネシ	SHOULDER SCREW, ;Z-CRANK	
7	155559001	1	ヒラサカネ	WASHER, PLAIN	
9	021060102	2	ナツト1シユ6	NUT, 1 M6	
10	S35258001	1	ハリフリクランク	ZIGZAG CRANK	
11	018062022	1	アナホリ 6X20	BOLT, SOCKET M6X20	
12	S35257000	1	クランクシクメタル	BUSH, ;C-SHAFT	
13	014060632	1	アナホミ 6X6	SET SCREW, SOCKET (CP) M6X6	
15	S35256001	1	ハリフリヨウトウシク	ROCKER SHAFT, ;ZIGZAG	
17	S35255001	1	ハリイッチヨウセツイタクミ	N-POSITION CONTROL PLATE ASSY	
18	S35252001	1	ハリフリハンシピン	PIN, ;Z-ECCENTRIC	
19	148727001	1	スパーサ-0.6	SPACER, 0.6	
20	S35250001	1	ハリフリウテ	ZIGZAG LEVER	
21	S35251001	1	ナツト6	NUT, M6	
22	S35332001	1	ハリホウタキ	NEEDLE BAR CLAMP	
23	018301236	1	アナホリ 3X12	BOLT, SOCKET M3X12	
24	S37432001	1	ハリホウアロツクダキクミ	BLOCK CLAMP ASSY, ;N-BAR	
24-1	S35143001	1	ハリホウアロツクダキ	BLOCK CLAMP, ;N-BAR	
24-2	018301632	1	アナホリ 3X16	BOLT, SOCKET M3X16	
26	153596001	1	サカネ	WASHER	

118-981-110

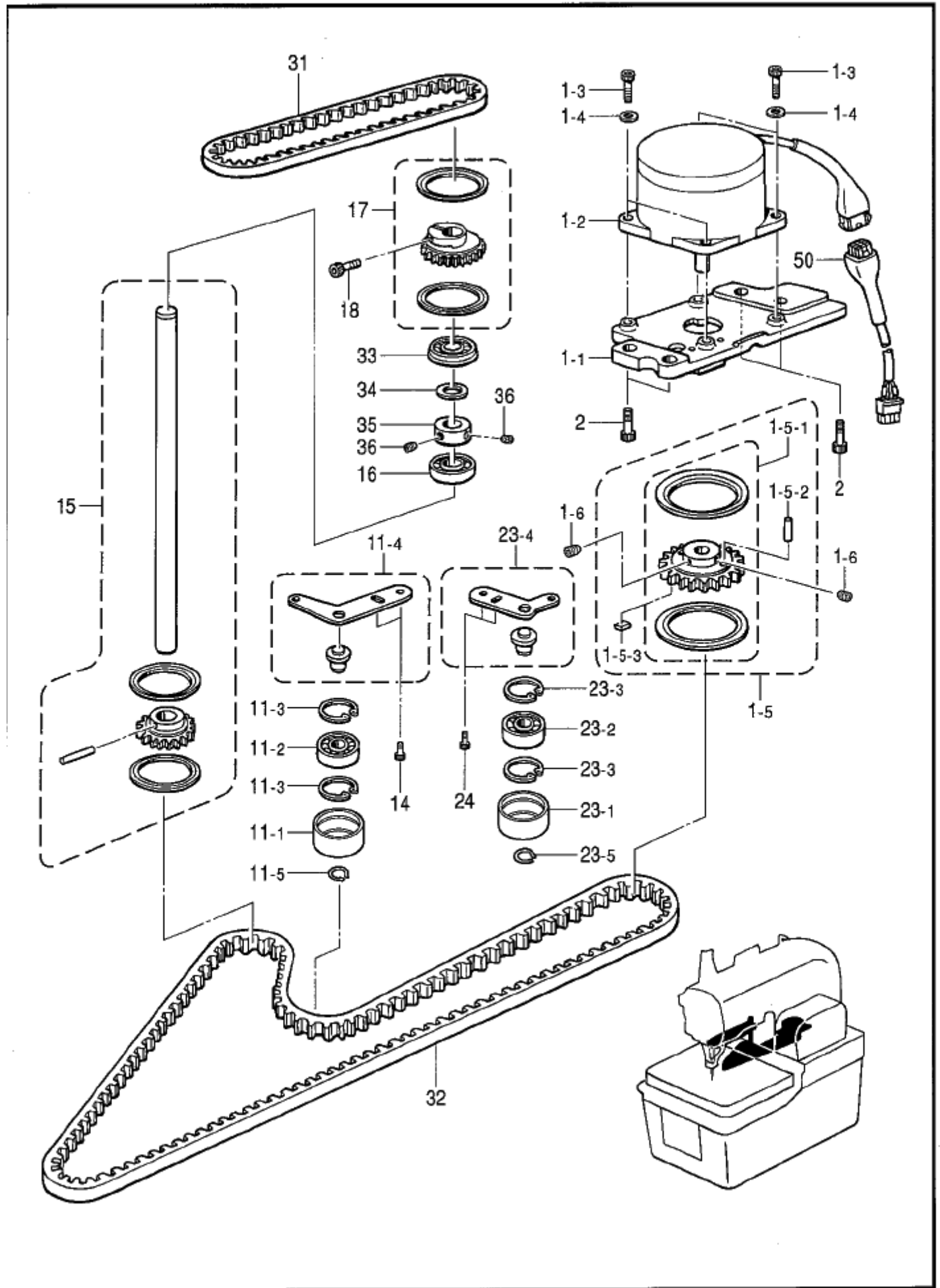

E. 針棒揺動関係 / Needle bar rocking mechanism

REF.NO	CODE	QTY	品名	NAME OF PARTS	RM
1-1	S35276101	1	モータベース	MOTOR BASE	
1-2	S43285000	1	パルスモータRクミ	PULSE MOTOR ASSY, R	
1-3	018501422	4	アナボルト5X14	BOLT, SOCKET M5X14	
1-4	025050232	4	ヒラサガネチユウ5	WASHER, PLAIN M 5	
1-5	S35283001	1	ハリカイトウフーリクミ	NEEDLE ROTATION PULLEY ASSY	
1-5-1	S35435000	1	ハリカイトウフーリクミ	NEEDLE ROTATION PULLEY ASSY, M	
1-5-2	S35282000	1	ニトヒン5X23.8	NEEDLE PIN, ;5X23.8	
1-5-3	128652001	1	マグネットREC16W	MAGNET REC16W	
1-6	014060632	2	アナボルトM6X6	SET SCREW, SOCKET (CP) M6X6	
2	018061622	4	アナボルト6X16	BOLT, SOCKET M6X16	
11	S35291101	1	テンションプーリDクミ	TENSION PULLEY ASSY, D	
11-1	S35284101	1	テンションプーリ	TENSION PULLEY	
11-2	076000800	1	タマシクウケ6000ZZ	BALL BEARING, 6000ZZ	
11-3	048260242	2	トメワアチヨウC26	RETAINING RING, INTERNAL C26	
11-4	S35290001	1	テンションプーリウテDクミ	TENSION PULLEY ARM ASSY, D	
11-5	048100142	1	トメワシクウケC10	RETAINING RING, EXTERNAL C10	
14	018400832	2	アナボルト4X8	BOLT, SOCKET M4X8	
15	S35296001	1	レースカイトウシククミ	DRIVING LOOPER SHAFT ASSY	
16	072620180	1	タマシクウケ6201ZZ	BALL BEARING, 6201ZZ	
17	S35297000	1	テジクテフーリUクミ	T-PULLEY ASSY, U ;V-SHAFT	
18	018401636	1	アナボルト4X16	BOLT, SOCKET M4X16	
23	S35288101	1	テンションプーリUクミ	TENSION PULLEY ASSY, U	
23-1	S35284101	1	テンションプーリ	TENSION PULLEY	
23-2	076000800	1	タマシクウケ6000ZZ	BALL BEARING, 6000ZZ	
23-3	048260242	1	トメワアチヨウC26	RETAINING RING, INTERNAL C26	
23-4	S35287001	1	テンションプーリウテUクミ	ARM ASSY, U ;T-PULLEY	
23-5	048100142	1	トメワシクウケC10	RETAINING RING, EXTERNAL C10	
24	018400832	2	アナボルト4X8	BOLT, SOCKET M4X8	
31	S35300000	1	タイミンクハルトU	TIMING BELT, U	
32	S35299000	1	タイミンクハルトD	TIMING BELT, D	
33	076001850	1	タマシクウケ6001ZZ	BALL BEARING, 6001ZZ	
34	142627001	1	サガネ	WASHER	
35	S35302001	1	セットカラー	SET SCREW COLLAR	
36	014060632	2	アナボルトM6X6	SET SCREW, SOCKET (CP) M6X6	
50	S43349100	1	パルスモータコードR	PULSE MOTOR CORD, R	

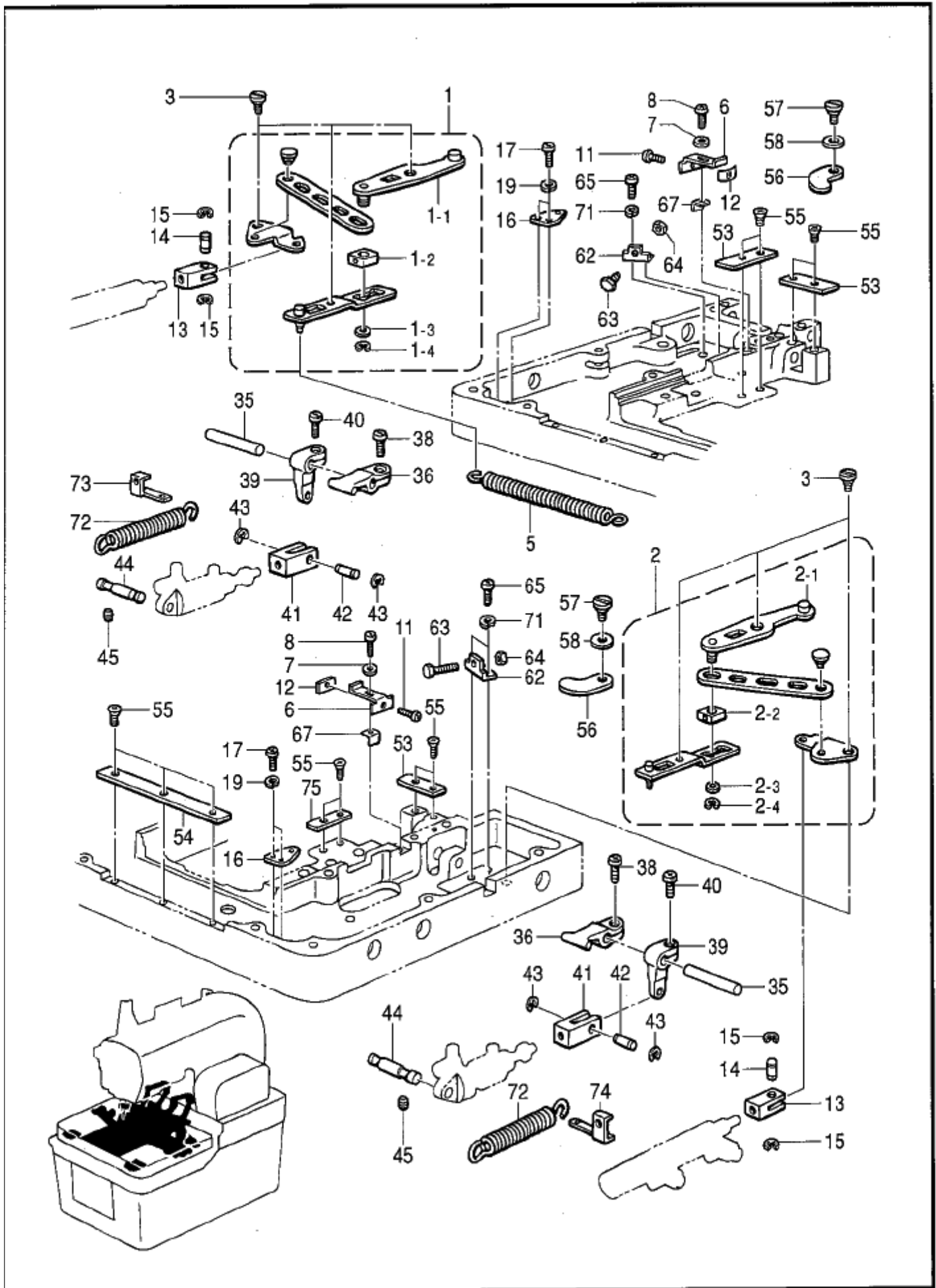

F1 . 押工関係 / Presser foot mechanism

REF.NO	CODE	Q'TY	ヒンメイ	NAME OF PARTS	RM
1	S34957001	1	ヒラキレカンLクミ	OPENING CONNECTING ROD ASSY, L	
1-1	S34965001	1	シテンレハ ^レ フ ^レ ートL	FULCRUM LEVER PLATE, L	
1-2	102630001	1	ハリホ ^ク アンナイカクマ	SLIDE BLOCK, N-BAR GUIDE	
1-3	109763002	1	サ ^カ ネ	WASHER	
1-4	048050342	1	トメワE5	RETAINING RING, E5	
2	S34963001	1	ヒラキレカンRクミ	OPENING CONNECTING ROD ASSY, R	
2-1	S34964001	1	シテンレハ ^レ フ ^レ ートR	FULCRUM LEVER PLATE, R	
2-2	102630001	1	ハリホ ^ク アンナイカクマ	SLIDE BLOCK, N-BAR GUIDE	
2-3	109763002	1	サ ^カ ネ	WASHER	
2-4	048050342	1	トメワE5	RETAINING RING, E5	
3	S34966001	6	ダンネシ ^ン M4	SHOULDER SCREW, M4	
5	S35429001	1	ヒラキハ ^ネ	SPRING, EXTENSION	
6	S34967001	2	ヒラキストツハ ^イ タ	STOPPER PLATE, ;OPENING	
7	025040232	2	ヒラサ ^カ ネチユウ4	WASHER, PLAIN M 4	
8	062400812	2	ハ ^コ 4X8	SCREW, PAN M4X8	
11	062301016	2	ハ ^コ M3X10	SCREW, PAN M3X10	
12	S34968000	2	スピ ^ト ナツトM3	SPEED NUT, M3	
13	S34970001	2	ヒラキシリンタ ^{ロツト}	CYLINDER ROD, ;OPENING	
14	S34969001	2	シリンタ ^{ロツト} ピンB	ROD PIN, B ;CYLINDER	
15	048030342	4	トメワE3	RETAINING RING, E3	
16	S35169001	2	ヒラキシリンタ ^{ササ} エ	CYLINDER SUPPORT, ;OPENING	
17	062400812	4	ハ ^コ 4X8	SCREW, PAN M4X8	
19	028040242	4	ハ ^ネ サ ^カ ネ2.4	WASHER, SPRING 2-4	
35	S35239101	2	クランプ ^{レハ} シ ^ク	CLAMP LEVER SHAFT	
36	S35240001	2	クランプ ^{レハ} B	CLAMP LEVER, B	
38	062501202	2	ハ ^コ M5X12	SCREW, PAN M5X12	
39	S35303201	2	オサ ^イ クト ^{ウレハ}	DRIVING LEVER	
40	062501202	2	ハ ^コ M5X12	SCREW, PAN M5X12	
41	S35166001	2	オサ ^イ シリンタ ^{ロツト}	CLAMP CYLINDER ROD	
42	S35305001	2	シリンタ ^{ロツト} ピン	ROD PIN, ;CYLINDER	
43	048030342	4	トメワE3	RETAINING RING, E3	
44	S35304001	2	クランプ ^{シリンタ} ササ ^エ	CYLINDER SUPPORT, ;CLAMP	
45	014400532	2	アサ ^ク ホ ^ミ 4X5	SET SCREW, SOCKET (CP) M4X5	
53	S35321001	3	フ ^レ ートカ ^イ イ ^イ A	GUIDE PLATE, A	
54	S35322001	1	フ ^レ ートカ ^イ イ ^イ B	GUIDE PLATE, B	
55	S06696004	11	サラコネシ ^ン 3X6	SCREW, FLAT M3X6	
56	S35323001	2	フ ^レ ートオサ ^エ	PLATE PRESSER	
57	S35324001	2	ダンネシ ^ン M4	SHOULDER SCREW, M4	
58	S36345000	2	マ ^ケ ワツヤ ^ー	WASHER, BENDING	
62	S35327001	2	ヒラキシリンタ ^{ストツハ}	STOPPER, ;O-CYLINDER	
63	017401415	2	ホ ^{ルト} 4X14	BOLT, M4X14	
64	021400202	2	シユナツト4	NUT, 2 M4	
65	062400812	4	ハ ^コ 4X8	SCREW, PAN M4X8	
67	S35328001	2	ヒラキストツハ ^ア イ ^タ	STOPPER PLATE	
71	028040242	4	ハ ^ネ サ ^カ ネ2.4	WASHER, SPRING 2-4	
72	S35456001	2	オサ ^イ モ ^ト シ ^ハ ネ	SPRING	
73	S35457001	1	ハ ^ネ カ ^ク L	SPRING HOOK, L	
74	S35458001	1	ハ ^ネ カ ^ク R	SPRING HOOK, R	
75	S35321001	1	フ ^レ ートカ ^イ イ ^イ A	GUIDE PLATE, A	

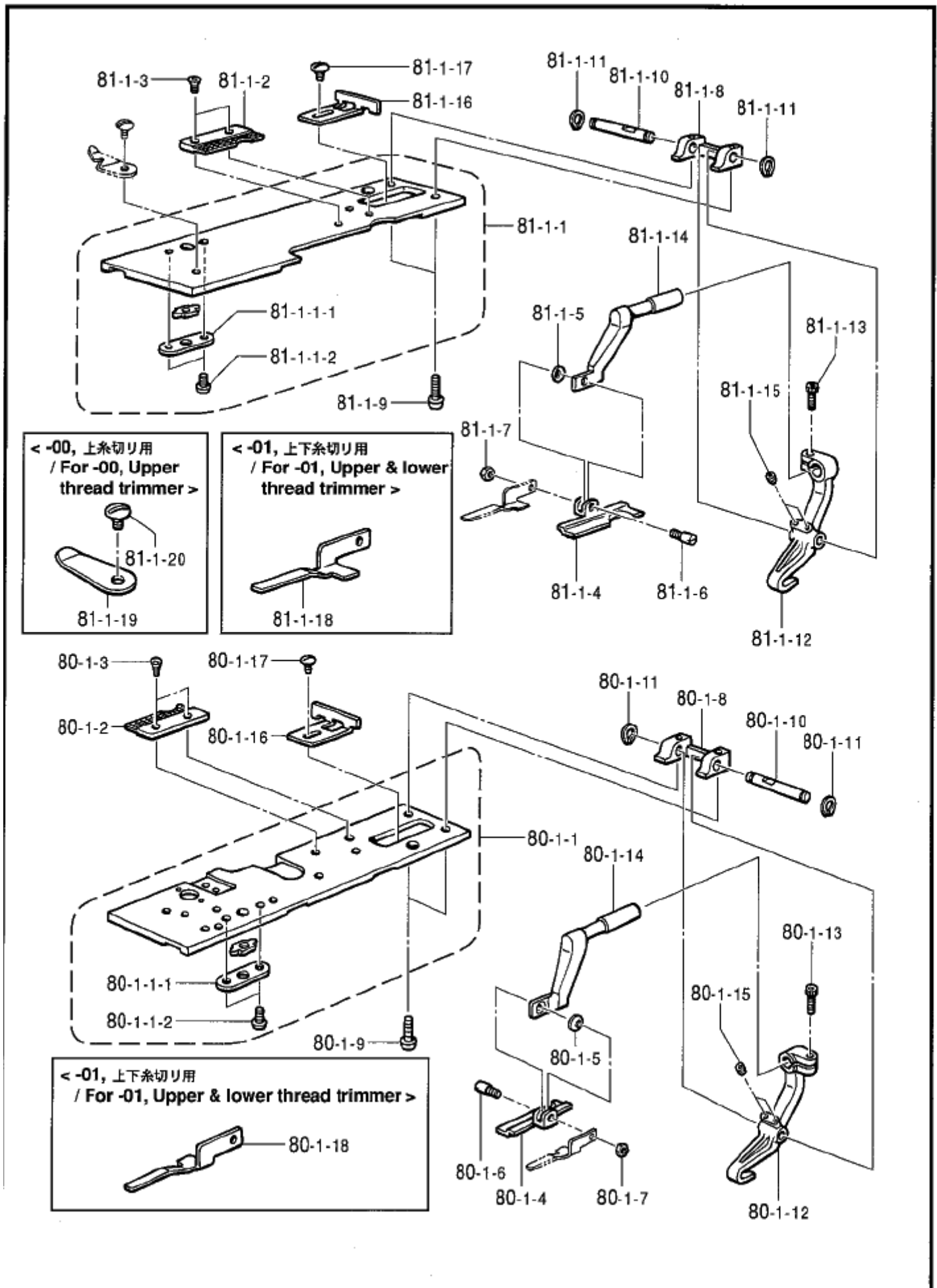

F2 . 押工関係 / Presser foot mechanism

REF.NO	CODE	Q'TY	品名	NAME OF PARTS	RM
			<-00, 上糸切り用>	<For-00, Upper thread trimmer>	
80-1	S35474401	1	オサエプレートRソクミ	WORK CLAMP PLATE SET, R	
80-1-1	S35318001	1	ヌノサエプレートRソクミ	WORK CLAMP PLATE ASSY, R	
80-1-2	S37684101	1	ハリイタR-50	NEEDLE PLATE, R-50	
80-1-4	S37680001	1	ヌノサエIR-50	WORK CLAMP, R-50	
			<-01, 上下糸切り用>	<For-01, Upper & lower thread trimmer>	
80-1	S35478401	1	オサエプレートRSソクミ	WORK CLAMP PLATE SET, RS	
80-1-1	S35319001	1	ヌノサエプレートRSソクミ	WORK CLAMP PLATE ASSY, RS	
80-1-2	S35309101	1	ハリイタR	NEEDLE PLATE, R	
80-1-4	S35452001	1	ヌノサエIRL	WORK CLAMP, RL	
80-1-18	S35330001	1	キシオサエイタR	WORK CLAMP PLATE, R	
80-1-1-1	S35316001	1	カコマサエイタ	SUPPORT PLATE, ;S-BLOCK	
80-1-1-2	060020416	2	ハイントM2X4	SCREW, BIND M2X4	
80-1-3	S06696004	2	サコネシ 3X6	SCREW, FLAT M3X6	
80-1-5	S35236000	1	マサガネ3.2	WASHER, BENDING 3.2	
80-1-6	S35235001	1	クランプサエピン	SUPPORT PIN, ;CLAMP	
80-1-7	021300302	1	3ユナツト3	NUT, 3 M3	
80-1-8	S35238001	1	クランプシクサ	SHAFT HOLDER, ;CLAMP	
80-1-9	062401016	2	ナハコ4X10	SCREW, PAN M4X10	
80-1-10	S35237001	1	クランプテンシク	FULCRUM SHAFT, ;CLAMP	
80-1-11	048050142	2	トワシクヨウC5	RETAINING RING, C5	
80-1-12	S35234201	1	クランプレバ-R	CLAMP LEVER, R	
80-1-13	018501236	1	アホネ5X12	BOLT, SOCKET M5X12	
80-1-14	S35167001	1	クランプア-R	CLAMP ARM, R	
80-1-15	014400532	2	アホネミ4X5	SET SCREW, SOCKET (CP) M4X5	
80-1-16	S35347000	1	ヌカイトR	CLOTH GUIDE, R	
80-1-17	S35326001	1	シメネシM3.5	SCREW, M3.5	
			<-00, 上糸切り用>	<For-00, Upper thread trimmer>	
81-1	S35475401	1	オサエプレートLソクミ	WORK CLAMP PLATE SET, L	
81-1-1	S35310001	1	ヌノサエプレートLソクミ	WORK CLAMP PLATE ASSY, L	
81-1-2	S37683101	1	ハリイタL-50	NEEDLE PLATE, L-50	
81-1-4	S37679001	1	ヌノサエIL-50	WORK CLAMP, L-50	
81-1-19	S38335000	1	イトホシイタ	THREAD HOLDING PLATE	
81-1-20	S35326001	1	シメネシM3.5	SCREW, M3.5	
			<-01, 上下糸切り用>	<For-01, Upper & lower thread trimmer>	
81-1	S35476401	1	オサエプレートLSソクミ	WORK CLAMP PLATE SET, LS	
81-1-1	S35317001	1	ヌノサエプレートLSソクミ	WORK CLAMP PLATE ASSY, LS	
81-1-2	S35308101	1	ハリイタL	NEEDLE PLATE, L	
81-1-4	S35453001	1	ヌノサエILL	WORK CLAMP, LL	
81-1-18	S35329001	1	キシオサエイタL	WORK CLAMP PLATE, L	
81-1-1-1	S35316001	1	カコマサエイタ	SUPPORT PLATE, ;S-BLOCK	
81-1-1-2	060020416	2	ハイントM2X4	SCREW, BIND M2X4	
81-1-3	S06696004	2	サコネシ 3X6	SCREW, FLAT M3X6	
81-1-5	S35236000	1	マサガネ3.2	WASHER, BENDING 3.2	
81-1-6	S35235001	1	クランプサエピン	SUPPORT PIN, ;CLAMP	
81-1-7	021300302	1	3ユナツト3	NUT, 3 M3	
81-1-8	S35238001	1	クランプシクサ	SHAFT HOLDER, ;CLAMP	
81-1-9	062401016	2	ナハコ4X10	SCREW, PAN M4X10	
81-1-10	S35237001	1	クランプテンシク	FULCRUM SHAFT, ;CLAMP	
81-1-11	048050142	2	トワシクヨウC5	RETAINING RING, C5	
81-1-12	S35233201	1	クランプレバ-L	CLAMP LEVER, L	
81-1-13	018501236	1	アホネ5X12	BOLT, SOCKET M5X12	
81-1-14	S35168001	1	クランプア-L	CLAMP ARM, L	
81-1-15	014400532	2	アホネミ4X5	SET SCREW, SOCKET (CP) M4X5	
81-1-16	S35348000	1	ヌカイトL	CLOTH GUIDE, L	
81-1-17	S35326001	1	シメネシM3.5	SCREW, M3.5	

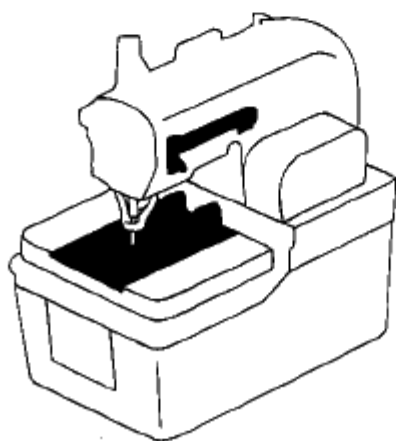
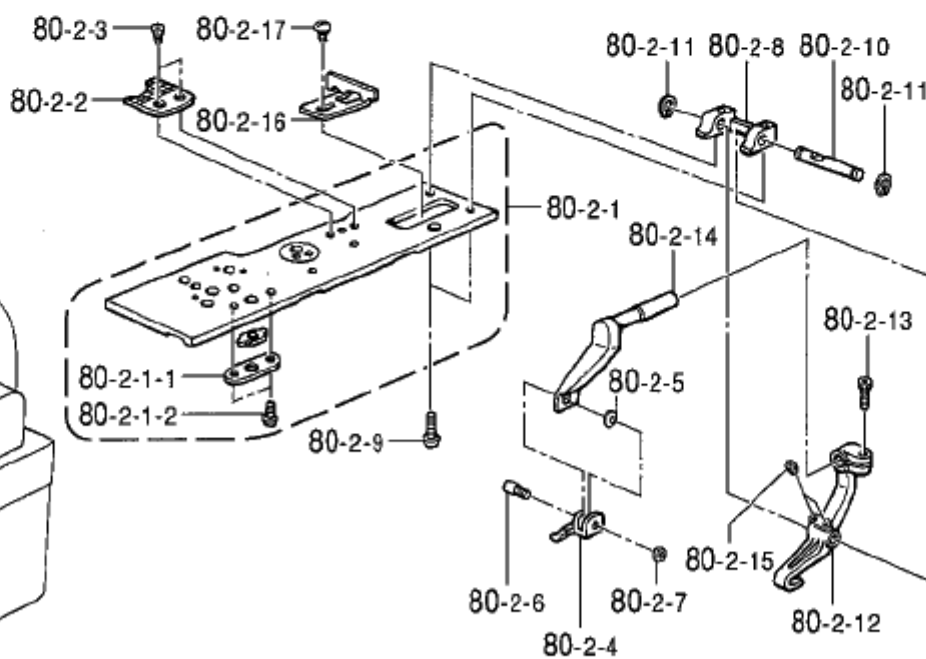
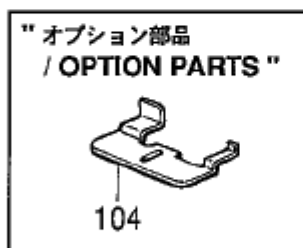
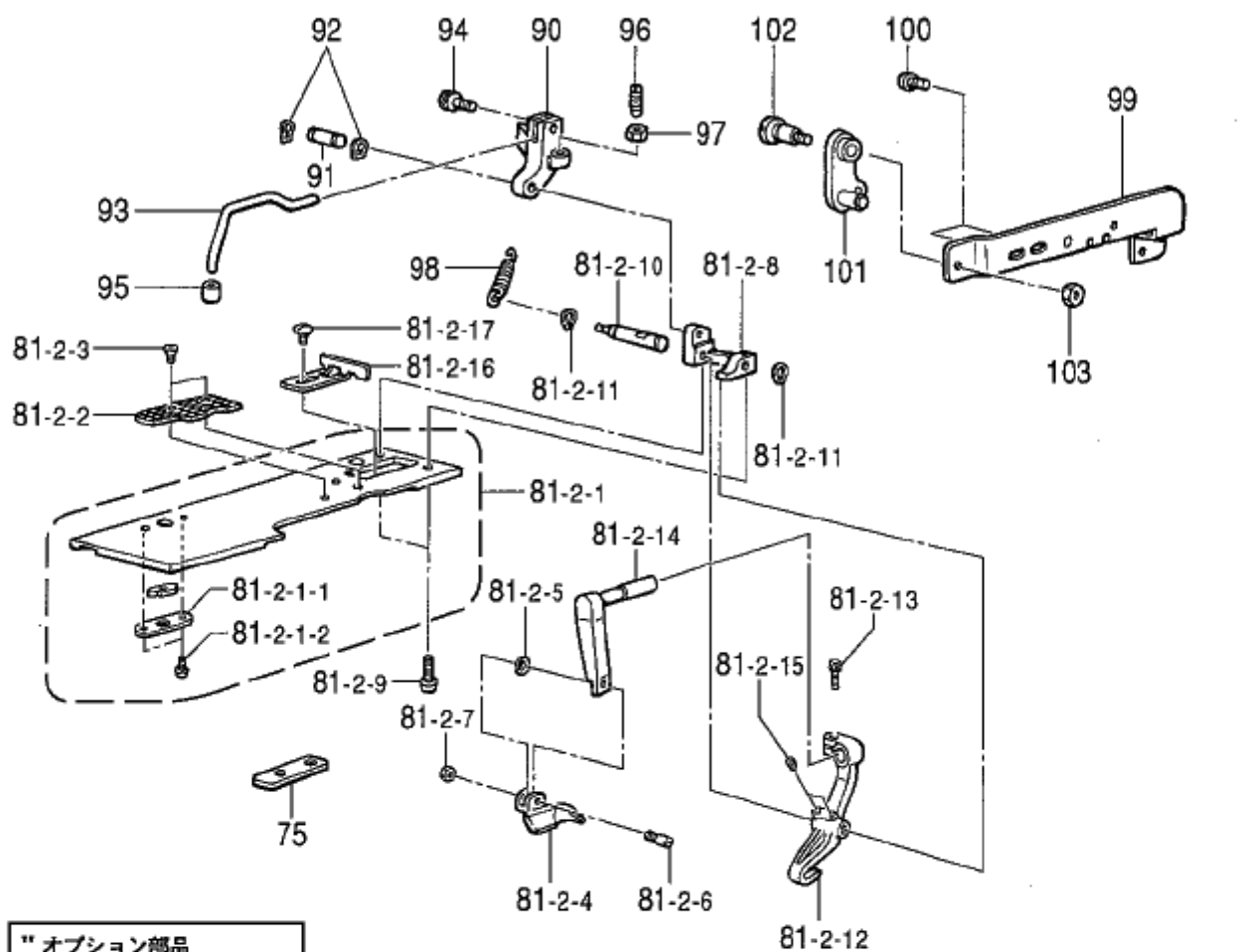

F3 . 押工関係 (ジーンズ仕様) / Presser foot mechanism (Jeans specification)

REF.NO	CODE	Q'TY	品名	NAME OF PARTS	RM
80-2	S37756401	1	<L1 14-18mm> オエア°レートJR1ソウクミ	<L1 14-18mm> WORK CLAMP PLATE SET, J R1	
80-2-2	S37644101	1	ハライ外1R	NEEDLE PLATE, R L1	
80-2-4	S37754001	1	ヌノオサIR-JL1	WORK CLAMP, R-J L1	
80-2	S37727401	1	<L2 18-22mm> オエア°レートJR2ソウクミ	<L2 18-22mm> WORK CLAMP PLATE SET, J R2	
80-2-2	S37646101	1	ハライ外2R	NEEDLE PLATE, R L2	
80-2-4	S37690001	1	ヌノオサIR-JL2	WORK CLAMP, R-J L2	
80-2	S37733401	1	<L3 22-26mm> オエア°レートJR3ソウクミ	<L3 22-26mm> WORK CLAMP PLATE SET, J R3	
80-2-2	S37648101	1	ハライ外3R	NEEDLE PLATE, R L3	
80-2-4	S37692001	1	ヌノオサIR-JL3	WORK CLAMP, R-J L3	
80-2	S37757401	1	<L4 26-30mm> オエア°レートJR4ソウクミ	<L4 26-30mm> WORK CLAMP PLATE SET, J R4	
80-2-2	S37650101	1	ハライ外4R	NEEDLE PLATE, R L4	
80-2-4	S37758001	1	ヌノオサIR-JL4	WORK CLAMP, R-J L4	
80-2	S40830101	1	<L5 28-32mm> オエア°レートJR5ソウクミ	<L5 28-32mm> WORK CLAMP PLATE SET, J R5	
80-2-2	S40822001	1	ハライ外5R	NEEDLE PLATE, R L5	
80-2-4	S41483001	1	ヌノオサIR-JL5	WORK CLAMP, R-J L5	
80-2	S41489101	1	<L6 32-36mm> オエア°レートJR6ソウクミ	<L6 32-36mm> WORK CLAMP PLATE SET, J R6	
80-2-2	S41479001	1	ハライ外6R	NEEDLE PLATE, R L6	
80-2-4	S41485001	1	ヌノオサIR-JL6	WORK CLAMP, R-J L6	
80-2	S41491101	1	<L7 36-40mm> オエア°レートJR7ソウクミ	<L7 36-40mm> WORK CLAMP PLATE SET, J R7	
80-2-2	S41481001	1	ハライ外7R	NEEDLE PLATE, R L7	
80-2-4	S41487001	1	ヌノオサIR-JL7	WORK CLAMP, R-J L7	
80-2-1	S37729101	1	<L1-L4 14-30mm> ヌノオサIA°レートJRクミ	<L1-L4 14-30mm> WORK CLAMP PLATE ASSY, JR	
80-2-1	S40828001	1	<L5-L7 28-40mm> ヌノオサIA°レートJRクミB	<L5-L7 28-40mm> WORK CLAMP PLATE ASSY, JR;B	
80-2-1-1	S35316001	1	カクコマサエイタ	SUPPORT PLATE, ;S-BLOCK	
80-2-1-2	060020416	2	ハ°イント°M2X4	SCREW, BIND M2X4	
80-2-3	S06696004	2	サヲコネシ° 3X6	SCREW, FLAT M3X6	
80-2-5	S35236000	1	ワ°サ°カ°ネ3.2	WASHER, BENDING 3.2	
80-2-6	S35235001	1	クランフ°ササヒ°ン	SUPPORT PIN, ;CLAMP	
80-2-7	021300302	1	3シユサツト3	NUT, 3 M3	
80-2-8	S35238001	1	クランフ°シ°クケ	SHAFT HOLDER, ;CLAMP	
80-2-9	062401016	2	ハ°コ4X10	SCREW, PAN M4X10	
80-2-10	S35237001	1	クランフ°シテンシ°ク	FULCRUM SHAFT, ;CLAMP	
80-2-11	048050142	2	トメワシ°クヨウC5	RETAINING RING, C5	
80-2-12	S35234201	1	クランフ°レハ°-R	CLAMP LEVER, R	
80-2-13	018501236	1	アサホ°ルト5X12	BOLT, SOCKET M5X12	
80-2-14	S37695001	1	<L1-L4 14-30mm> クランフ°ア°IR-J	<L1-L4 14-30mm> CLAMP ARM, R-J	
80-2-14	S40826001	1	<L5-L7 28-40mm> クランフ°ア°IR-J-B	<L5-L7 28-40mm> CLAMP ARM, R-J-B	
80-2-15	014400532	2	アサホ°ミ4X5	SET SCREW, SOCKET (CP) M4X5	

F3. 押工関係 (ジーンズ仕様) / Presser foot mechanism (Jeans specification)

REF.NO	CODE	QTY	ヒンメイ	NAME OF PARTS	RM
80-2-16	S35347000	1	ヌカイトR	CLOTH GUIDE, R	
80-2-17	S35326001	1	シメネジM3.5	SCREW, M3.5	
81-2	S37731301	1	<L1 14-18mm> オサエプレートJL1ソクミ	<L1 14-18mm> WORK CLAMP PLATE SET, J L1	
81-2-2	S37643201	1	ハリイタL1L	NEEDLE PLATE, L L1	
81-2-4	S37755001	1	ヌノサエL-JL1	WORK CLAMP, L-J L1	
81-2	S37728301	1	<L2 18-22mm> オサエプレートJL2ソクミ	<L2 18-22mm> WORK CLAMP PLATE SET, J L2	
81-2-2	S37645101	1	ハリイタL2L	NEEDLE PLATE, L2 L	
81-2-4	S37689001	1	ヌノサエL-JL2	WORK CLAMP, L-J L2	
81-2	S37735301	1	<L3 22-26mm> オサエプレートJL3ソクミ	<L3 22-26mm> WORK CLAMP PLATE SET, J L3	
81-2-2	S37647101	1	ハリイタL3L	NEEDLE PLATE, L L3	
81-2-4	S37691001	1	ヌノサエL-JL3	WORK CLAMP, L-J L3	
81-2	S37732301	1	<L4 26-30mm> オサエプレートJL4ソクミ	<L4 26-30mm> WORK CLAMP PLATE SET, J L4	
81-2-2	S37649101	1	ハリイタL4L	NEEDLE PLATE, L L4	
81-2-4	S37759001	1	ヌノサエL-JL4	WORK CLAMP, L-J L4	
81-2	S40831101	1	<L5 28-32mm> オサエプレートJL5ソクミ	<L5 28-32mm> WORK CLAMP PLATE SET, J L5	
81-2-2	S40823001	1	ハリイタL5L	NEEDLE PLATE, L L5	
81-2-4	S41484001	1	ヌノサエL-JL5	WORK CLAMP, L-J L5	
81-2	S41490101	1	<L6 32-36mm> オサエプレートJL6ソクミ	<L6 32-36mm> WORK CLAMP PLATE SET, J L6	
81-2-2	S41480001	1	ハリイタL6L	NEEDLE PLATE, L L6	
81-2-4	S41486001	1	ヌノサエL-JL6	WORK CLAMP, L-J L6	
81-2	S41492101	1	<L7 36-40mm> オサエプレートJL7ソクミ	<L7 36-40mm> WORK CLAMP PLATE SET, J L7	
81-2-2	S41482001	1	ハリイタL7L	NEEDLE PLATE, L L7	
81-2-4	S41488001	1	ヌノサエL-JL7	WORK CLAMP, L-J L7	
81-2-1	S37730001	1	<L1-L4 14-30mm> オサエプレートJLクミ	<L1-L4 14-30mm> WORK CLAMP PLATE ASSY, JL	
81-2-1	S35310001	1	<L5-L7 28-40mm> ヌノサエプレートLクミ	<L5-L7 28-40mm> WORK CLAMP PLATE ASSY, L	
81-2-1-1	S35316001	1	カクマササエイタ	SUPPORT PLATE, ;S-BLOCK	
81-2-1-2	060020416	2	バインドM2X4	SCREW, BIND M2X4	
81-2-3	S06696004	2	サラコネジ3X6	SCREW, FLAT M3X6	
81-2-5	S35236000	1	マゲサガネ3.2	WASHER, BENDING 3.2	
81-2-6	S35235001	1	クランプササエピン	SUPPORT PIN, ;CLAMP	
81-2-7	021300302	1	3シュナツ3	NUT, 3 M3	
81-2-8	S37712001	1	クランプジクウケ	CLAMP SHAFT HOLDER	
81-2-9	062401016	2	ナベコ4X10	SCREW, PAN M4X10	
81-2-10	S37711001	1	クランプシテンジク	CLAMP FULCRUM SHAFT	
81-2-11	048050142	2	トメジクヨウC5	RETAINING RING, C5	
81-2-12	S35233201	1	クランプレバーL	CLAMP LEVER, L	
81-2-13	018501236	1	アナボルト5X12	BOLT, SOCKET M5X12	

F3 . 押工関係 (ジーンズ仕様) / Presser foot mechanism (Jeans specification)

REF.NO	CODE	QTY	ヒンメイ	NAME OF PARTS	RM
81-2-14	S37694001	1	<L1-L4 14-30mm> クランプアームL-J	<L1-L4 14-30mm> CLAMP ARM, L-J	
81-2-14	S40827001	1	<L5-L7 28-40mm> クランプアームL-J-B	<L5-L7 28-40mm> CLAMP ARM, L-J-B	
81-2-15	014400532	2	アタネ M4X5	SET SCREW, SOCKET (CP) M4X5	
81-2-16	S35348000	1	ヌガイト L	CLOTH GUIDE, L	
81-2-17	S35326001	1	シメネジ M3.5	SCREW, M3.5	
75	S37693001	1	プレートガイドイタC	GUIDE PLATE, C	
90	S37714001	1	ボシヨサエテンタイ	FULCRUM BRACKET, ;AUX.CLAMP	
91	S37713001	1	ボシヨサエテンシク	FULCRUM SHAFT, ;AUX.CLAMP	
92	048050142	2	トメワシクヨウC5	RETAINING RING, C5	
93	S37718000	1	ボシヨサエウテ	AUXILIARY CLAMP ARM	
94	018401032	1	アタネ M4X10	BOLT, SOCKET M4X10	
95	S05356000	1	ボタンサア	BUTTON CLAMP, A	
96	S08808001	1	ストップネジ	STOPPER SCREW	
97	021660102	1	ナット M3.18	NUT, 1 SM3.18	
98	S37753001	1	ボシヨサエトシハネ	SPRING, EXTENSION	
99	S37744001	1	円筒ササエ	CYLINDER SUPPORT ASSY	
100	062400812	2	ナベコ M4X8	SCREW, PAN M4X8	
101	S37717101	1	ボシヨサエリンク	AUX. CLAMP LINK ASSY	
102	S34922101	1	ダンネジ M4	SHOULDER SCREW, M4	
103	021400202	1	2シユナット M4	NUT, 2 M4	
104	S37870000	1	"オプション部品" ヌガイト J	"OPTION PARTS" CLOTH GUIDE, J	

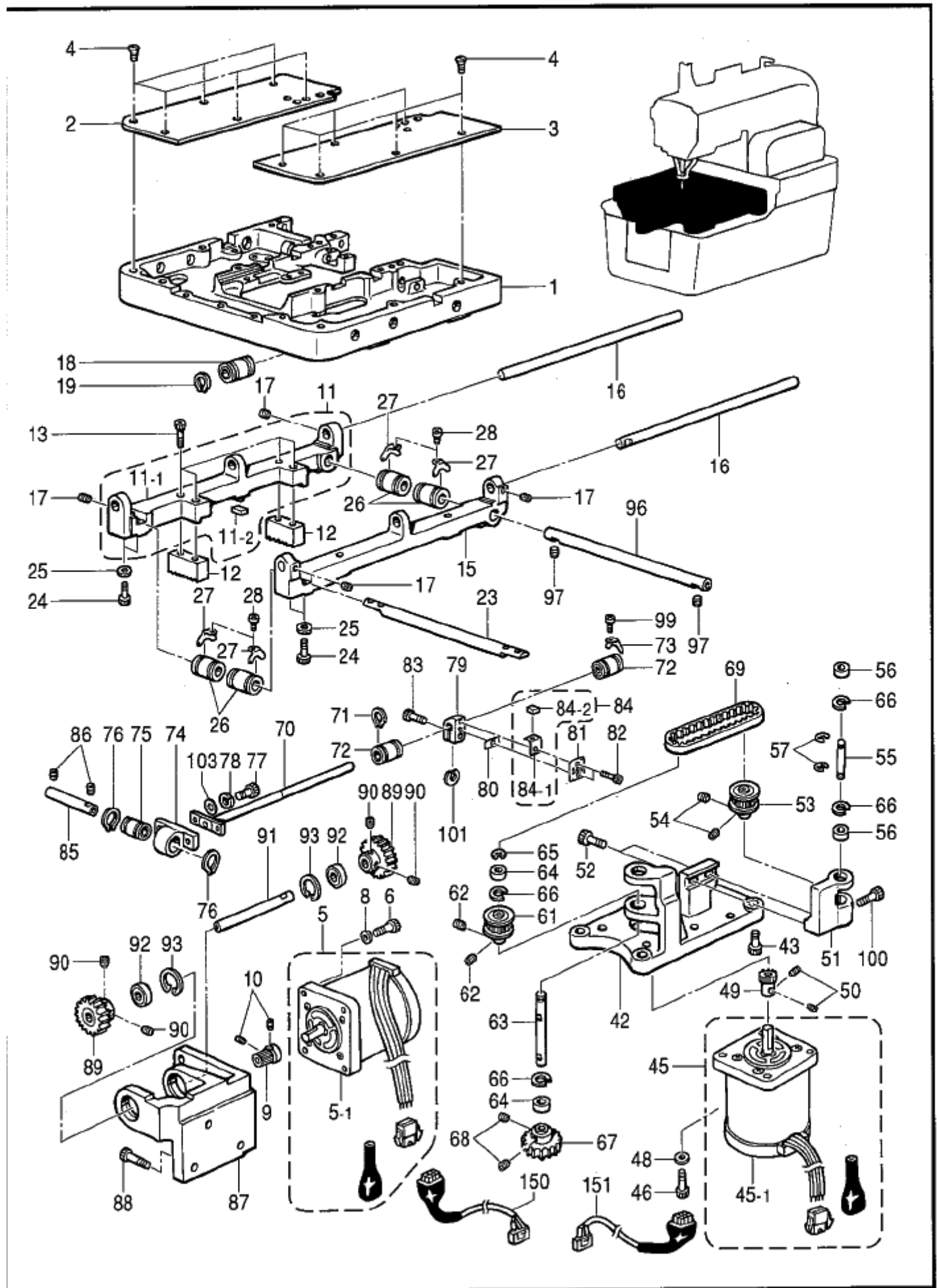

G. 送り関係 / Feed mechanism

REF.NO	CODE	Q'TY	ヒンメイ	NAME OF PARTS	RM
1	S34950209	1	オリタイ	FEED BRACKET	
2	S35176001	1	オリタイイカハ-L	FEED BRACKET COVER, L	
3	S35177001	1	オリタイイカハ-R	FEED BRACKET COVER, R	
4	S29410001	12	サネシ M4	SCREW, FLAT M4	
5	S43192200	1	ハルスモータXクミ	PULSE MOTOR ASSY, X	
5-1	S43193200	1	ハルスモータ103H7523	PULSE MOTOR, 103H7523	
6	018401622	4	アホルト4X16	BOLT, SOCKET M4X16	
8	025040132	4	ヒラサガネシヨウ4	WASHER, PLAIN S 4	
9	S43717201	1	クウキヤ15.75	GEAR, 15.75	
10	014770622	2	アトメネシ6.35クホミ	SET SCREW, SOCKET (CP) SM6.35	
11	S35181001	1	Xオクリンクウカクミ	X-FEED SHAFT HOLDER ASSY, L	
11-1	S35180000	1	XオクリンクウカL	X-FEED SHAFT HOLDER, L	
11-2	417526000	1	センサマグネット9	SENSOR MAGNET, 9	
12	S35178001	2	Xラック	X-RACK	
13	018501631	4	アホルト5X16	BOLT, SOCKET M5X16	
15	S35179000	1	XオクリンクウカR	X-FEED SHAFT HOLDER, R	
16	S35188001	2	Yオクリアンナインク	Y-FEED GUIDE SHAFT	
17	014060632	4	アホルトミ6X6	SET SCREW, SOCKET (CP) M6X6	
18	S12004000	4	リアブツシュ	LINEAR BUSH	
19	S02460001	8	トメワジクヨウC19	RETAINING RING, EXTERNAL C19	
23	S35182001	1	XオクリアンナインクA	X-FEED GUIDE SHAFT, A	
24	018401636	4	アホルト4X16	BOLT, SOCKET M4X16	
25	025040232	4	ヒラサガネシヨウ4	WASHER, PLAIN M 4	
26	S35183000	4	リアブツシュ12	LINEAR BUSH, 12	
27	S35184001	4	タマシクウケトメイタ	STOPPER, BALL BEARING	
28	062300416	4	ハネコM3X4	SCREW, PAN M3X4	
42	S43719001	1	YオクリハネSB	Y-FEED BASE, B	
43	018061622	4	アホルト6X16	BOLT, SOCKET M6X16	
45	S43194200	1	ハルスモータYクミ	PULSE MOTOR ASSY, Y	
45-1	S43193200	1	ハルスモータ103H7523	PULSE MOTOR, 103H7523	
46	018401622	4	アホルト4X16	BOLT, SOCKET M4X16	
48	025040132	4	ヒラサガネシヨウ4	WASHER, PLAIN S 4	
49	S43718001	1	クウキヤ25	DRIVING GEAR, 25	
50	014760622	2	アトメネシ5.95	SET SCREW, SOCKET SM5.95	
51	S35174001	1	YフーリササIL	Y-PULLEY SUPPORT, L	
52	018501422	2	アホルト5X14	BOLT, SOCKET M5X14	
53	S27844201	1	タイミングプーリア	TIMING PULLEY, A	
54	014770622	2	アトメネシ6.35クホミ	SET SCREW, SOCKET (CP) SM6.35	
55	S35186001	1	YフーリシクL	Y-PULLEY SHAFT, L	
56	530138001	2	マイクロベアリング8	MICRO BEARING, 8	
57	048060342	2	トメワE6	RETAINING RING, E6	
61	S27844201	1	タイミングプーリア	TIMING PULLEY, A	
62	014770622	2	アトメネシ6.35クホミ	SET SCREW, SOCKET (CP) SM6.35	
63	S35189001	1	YフーリシクR	Y-PULLEY SHAFT, R	
64	530138001	2	マイクロベアリング8	MICRO BEARING, 8	
65	048060342	1	トメワE6	RETAINING RING, E6	
66	048160242	4	トメワアナヨウC16	RETAINING RING, INTERNAL C16	
67	S43720001	1	アイドルキヤ40	IDLER GEAR, 40	
68	014060632	2	アホルトミ6X6	SET SCREW, SOCKET (CP) M6X6	
69	S10077100	1	Yタイミングベルト	Y-TIMING BELT	
70	S35190001	1	Yシク	Y-SHAFT	
71	S02460001	2	トメワジクヨウC19	RETAINING RING, EXTERNAL C19	
72	S12004000	2	リアブツシュ	LINEAR BUSH	
73	S35184001	1	タマシクウケトメイタ	STOPPER, BALL BEARING	
74	S35191001	1	ジクウケ	BALL BEARING	
75	S12004000	1	リアブツシュ	LINEAR BUSH	
76	S02460001	2	トメワジクヨウC19	RETAINING RING, EXTERNAL C19	
77	018061222	2	アホルト6X12	BOLT, SOCKET M6X12	
78	028060242	2	ハネサガネ2-6	WASHER, SPRING 2-6	
79	S31568000	1	Yクウシクホルダ	Y-DRIVING SHAFT HOLDER	
80	S10078001	1	Tベルトスペーサ	SPACER, T-BELT	

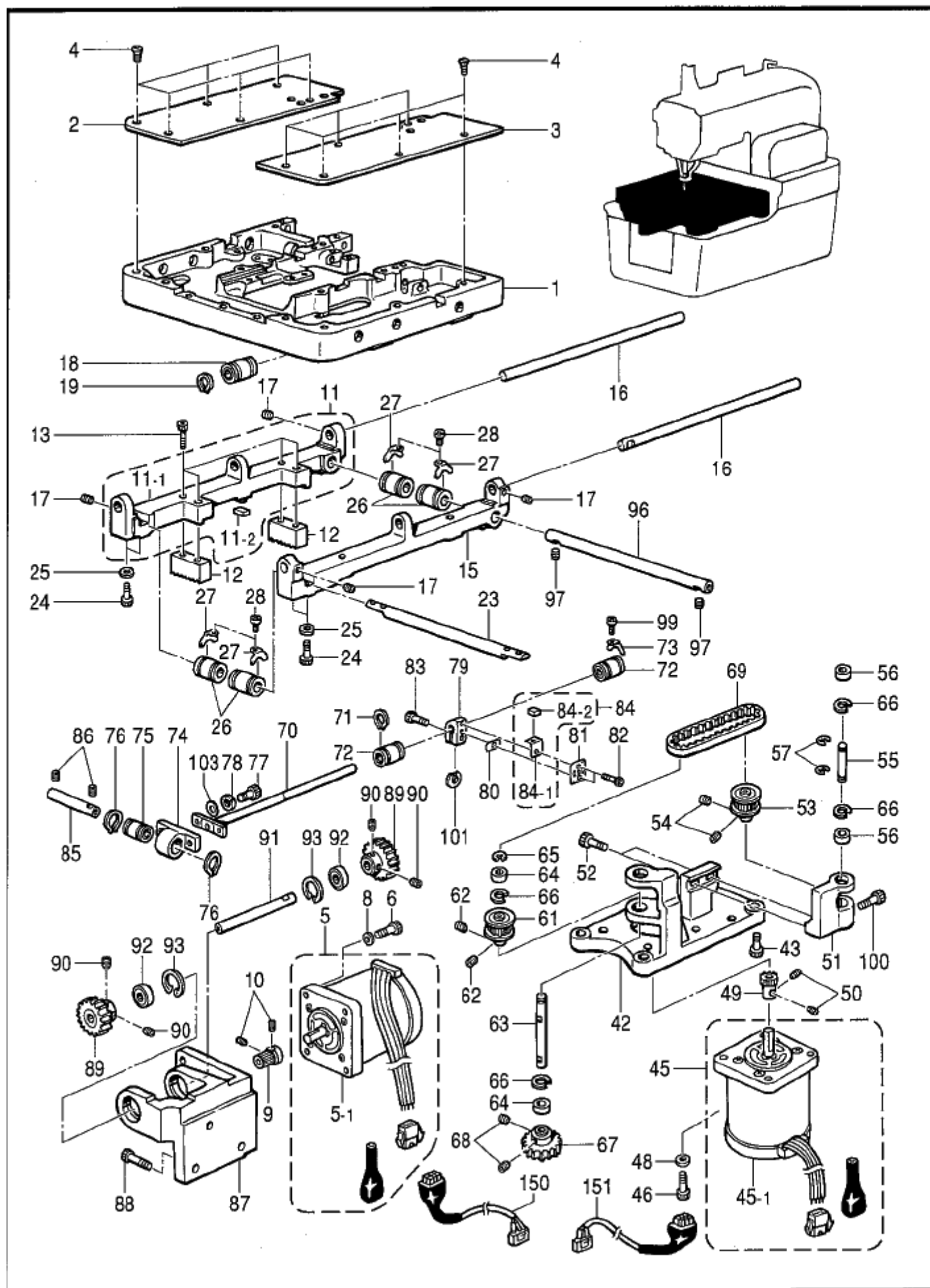

G. 送り関係 / Feed mechanism

REF.NO	CODE	QTY	ヒンメイ	NAME OF PARTS	RM
81	S10079101	1	ベルトホルダ	BELT HOLDER	
82	018680822	2	アボルト4.37X8	BOLT, SOCKET SM4.37X8	
83	018501631	1	アボルト5X16	BOLT, SOCKET M5X16	
84	S35192001	1	センサリイタミ	SENSOR PARTITION PLATE ASSY	
84-1	S35193000	1	センサリイタ	SENSOR PARTITION PLATE	
84-2	128652001	1	マグネットREC16W	MAGNET REC16W	
85	S35194001	1	Yガイドシャフト	Y-GUIDE SHAFT	
86	012500536	2	アヒラ5X5	SET SCREW, SOCKET (FT) M5X5	
87	S43749001	1	モータサヤB	MOTOR SUPPORT, B	
88	018061622	3	アボルト6X16	BOLT, SOCKET M6X16	
89	S35196100	2	アイドルギヤ	IDLER GEAR	
90	014060632	4	アボルト6X6	SET SCREW, SOCKET (CP) M6X6	
91	S35195001	1	アイドルギヤシャフト	GEAR SHAFT, ;IDLER	
92	076001800	2	タシクウケ6001ZZ	BALL-BEARING 6001ZZ(8482.10)	
93	048280242	2	トメアアヨウC28	RETAINING RING, INTERNAL C28	
96	S35187001	1	XオクリアンナイシクB	X-FEED GUIDE SHAFT, B	
97	014060632	2	アボルト6X6	SET SCREW, SOCKET (CP) M6X6	
99	062300416	1	ナットM3X4	SCREW, PAN M3X4	
100	018502022	1	アボルト5X20	BOLT, SOCKET M5X20	
101	148782001	1	スペーサ	SPACER	
103	025060232	2	ヒラサカネチユウ6	WASHER, PLAIN M 6	
150	S43347000	1	パルスモータコードX	PULSE MOTOR CORD, X	
151	S43348000	1	パルスモータコードY	PULSE MOTOR CORD, Y	

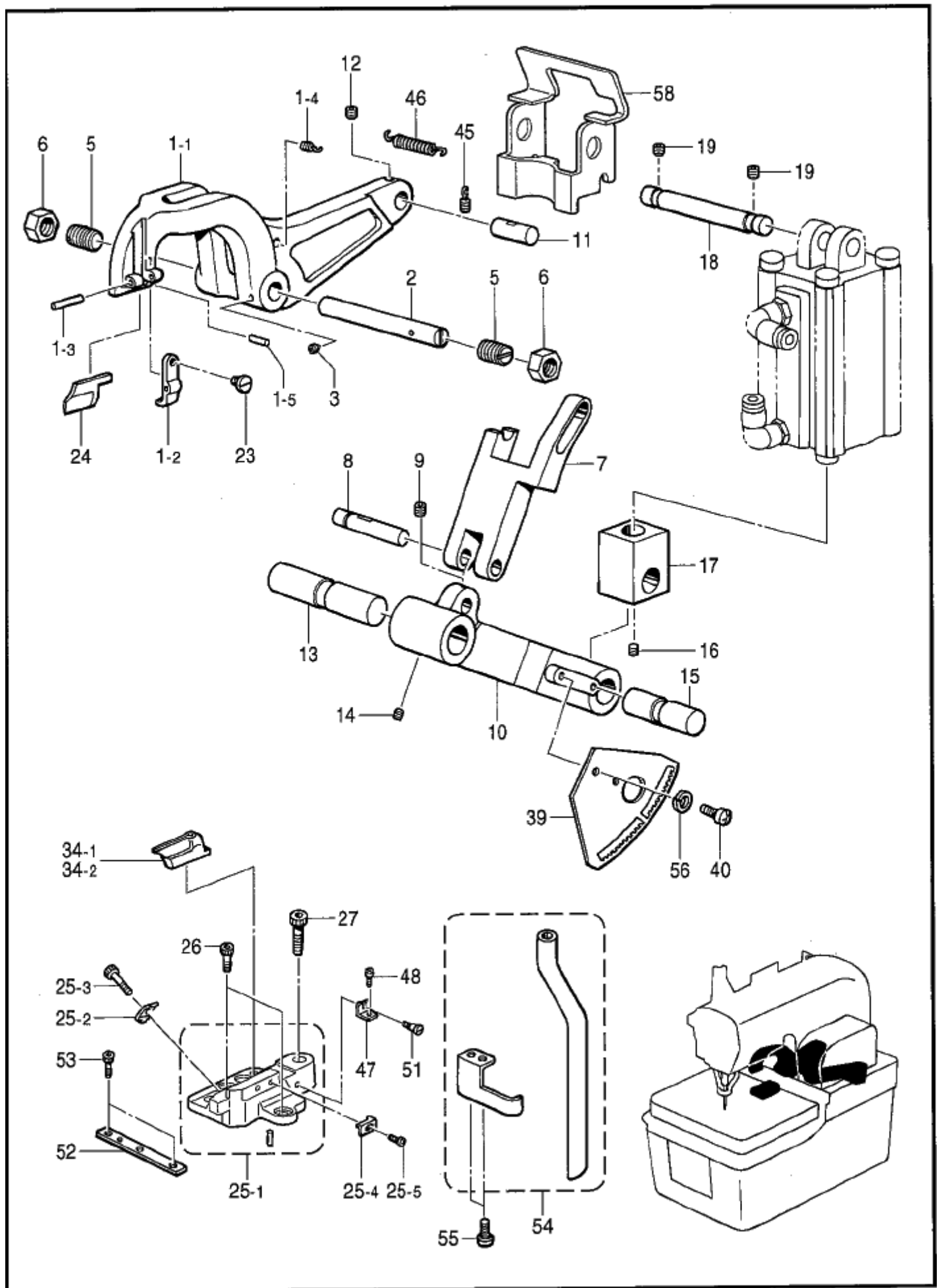

H. カッター関係 / Cutter mechanism

REF.NO	CODE	Q'TY	ヒンメイ	NAME OF PARTS	RM
1	S35074201	1	カッターウテ`クミ	CUTTER LEVER ASSY	
1-1	S35075201	1	カッターウテ`	CUTTER LEVER	
1-2	S35076101	1	カッターカートリッジ`サエ	CUTTER CARTRIDGE PRESSER	
1-3	S35077000	1	ニト`ルロ`ヲ4X25.8	NEEDLE ROLLER, 4X25.8	
1-4	S35078001	1	ハ`ネカク	SPRING HOOK	
1-5	S35079000	1	ニト`ルロ`ヲ3X11.8	NEEDLE ROLLER, 3X11.8	
2	S35080001	1	カッターウテ`シ`ク	CUTTER LEVER SHAFT	
3	016061031	1	アサカ`リ 6X10	SET SCREW, SOCKET (CN) M6X10	
5	S35081001	2	カッターウテ`サエネジ`	SUPPORT SCREW	
6	S35082001	2	3`ユサツト14	NUT, 3 M14	
7	S35088001	1	リンクA	LINK, A	
8	S35085001	1	リンクシ`クC	LINK SHAFT, C	
9	014060632	1	アサカ`ネ`ミ6X6	SET SCREW, SOCKET (CP) M6X6	
10	S35087001	1	リンクC	LINK, C	
11	S35086001	1	リンクシ`クB	LINK SHAFT, B	
12	014060632	1	アサカ`ネ`ミ6X6	SET SCREW, SOCKET (CP) M6X6	
13	S35083001	1	リンクシ`クA	LINK SHAFT, A	
14	014060632	1	アサカ`ネ`ミ6X6	SET SCREW, SOCKET (CP) M6X6	
15	S35084001	1	シリンダ`ロツト`シ`ク	CYLINDER ROD SHAFT	
16	014060632	1	アサカ`ネ`ミ6X6	SET SCREW, SOCKET (CP) M6X6	
17	S35089001	1	シリンダ`ロツト`	CYLINDER ROD	
18	S35090001	1	シリンダ`サエシ`ク	CYLINDER SUPPORT SHAFT	
19	014060632	2	アサカ`ネ`ミ6X6	SET SCREW, SOCKET (CP) M6X6	
23	S35091001	1	ツマミネジ`M5	KNOB SCREW, M5	
			<-00, 上糸切り用>	<For-00, Upper thread trimmer>	
24	S35093001	1	<-01, 上下糸切り用> ハンマー-38	<For-01, Upper & lower thread trimmer> HAMMER, 38	
			<-02, ジーンズ仕様>	<For-02, jeans specification>	
24	S37702001	1	<-52, フライインデクサー仕様> ハンマー-S12.....L1	<For-52, Fly indexer specification> HAMMER, S12.....L1	
24	S37704001	1	ハンマー-S16.....L2	HAMMER, S16.....L2	
24	S37706001	1	ハンマー-S20.....L3	HAMMER, S20.....L3	
24	S37708001	1	ハンマー-S24.....L4	HAMMER, S24.....L4	
24	S37197001	1	ハンマー-26L5	HAMMER, 26.....L5	
24	S37199001	1	ハンマー-30L6	HAMMER, 30.....L6	
24	S37201001	1	ハンマー-34L7	HAMMER, 34.....L7	
25	S35473301	1	メスト`タ`イソクミ	KNIFE BRACKET SET	
25-1	S35094301	1	メスト`タ`イクミ	KNIFE BRACKET ASSY	
25-2	S35097001	1	メソフ`ロツクサエ	KNIFE BLOCK HOLDER	
25-3	018501622	1	アサカ`ルト5X16	BOLT, SOCKET M5X16	
25-4	S35098000	1	フ`ロツクストップ`イ`タ	STOPPER PLATE, ;BLOCK	
25-5	062300416	1	ナハ`コM3X4	SCREW, PAN M3X4	
26	018501222	2	アサカ`ルト5X12	BOLT, SOCKET M5X12	
27	018062522	1	アサカ`ルト6X25	BOLT, SOCKET M6X25	
34-1	S35436101	1	メス2. 8X4. 3-50	KNIFE, 2.8X4.3-50	
34-2	S35437101	1	メス2. 8X4. 3-38	KNIFE, 2.8X4.3-38	
39	S45269001	1	カッターセンサー`キリイ`タS	PARTITION PLATE, ;C-SENSOR	
40	062400812	2	ナハ`コ4X8	SCREW, PAN M4X8	
45	S35078001	1	ハ`ネカク	SPRING HOOK	
46	142642001	1	サト`ウチヨウセツキ`キハ`ネ	SPRING, EXTENSION	
47	S35100001	1	メスチヨウセツサエ	KNIFE ADJUSTING SUPPORT	
48	062400812	1	ナハ`コ4X8	SCREW, PAN M4X8	
51	S35101001	1	メスチヨウセツネジ`	ADJUSTING SCREW	
52	S35102001	1	メスト`タ`イソクミ	KNIFE BRACKET GUIDE	
53	018400832	3	アサカ`ルト4X8	BOLT, SOCKET M4X8	
54	S35104001	1	メソハ`イフ`クミ	KNIFE PIPE ASSY	
55	062400812	2	ナハ`コ4X8	SCREW, PAN M4X8	
56	028040242	2	ハ`ネサ`カ`ネ2.4	WASHER, SPRING 2-4	
58	S43375000	1	メスウテ`カハ`-	KNIFE LEVER COVER	

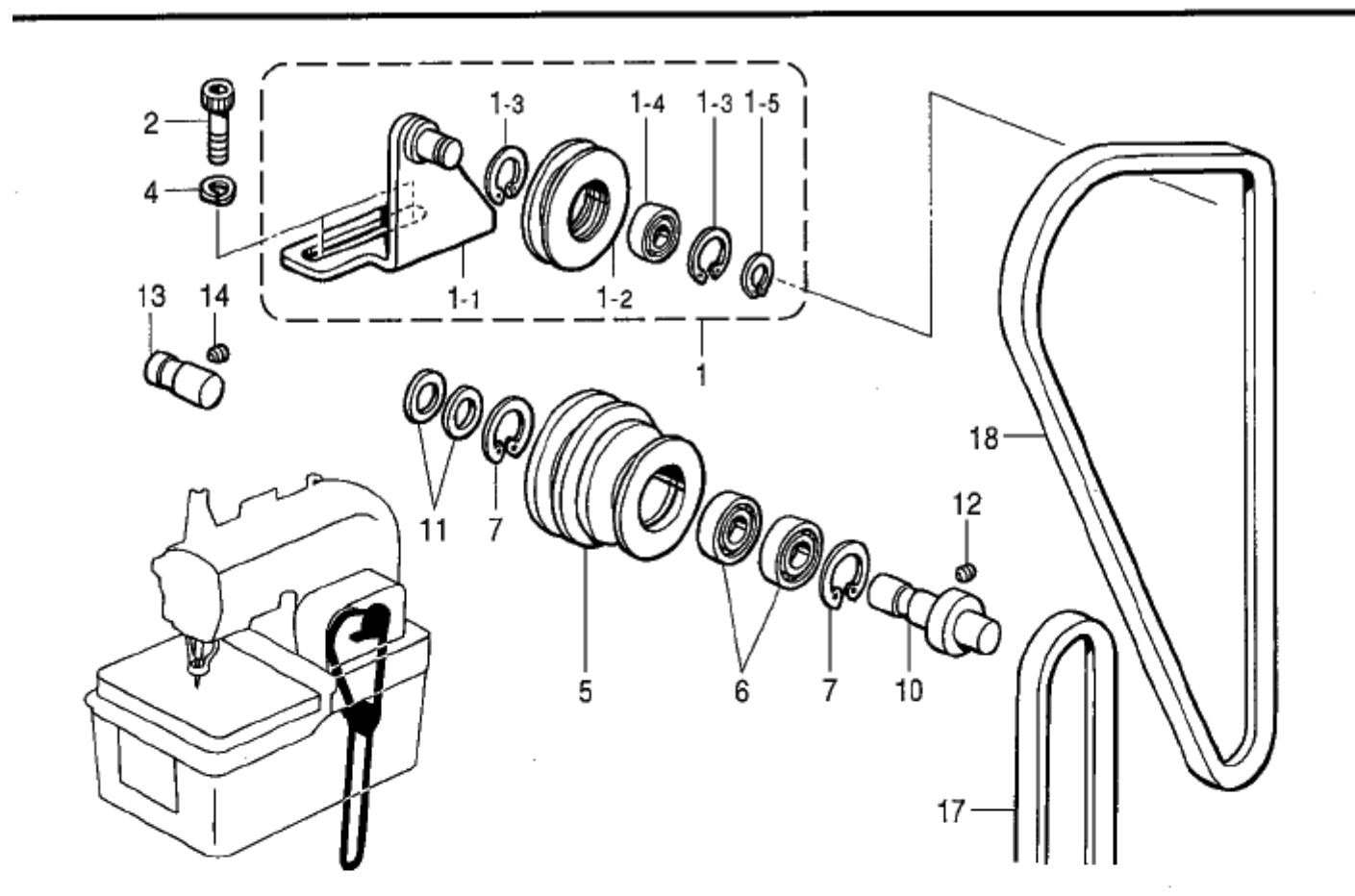

118-981-126

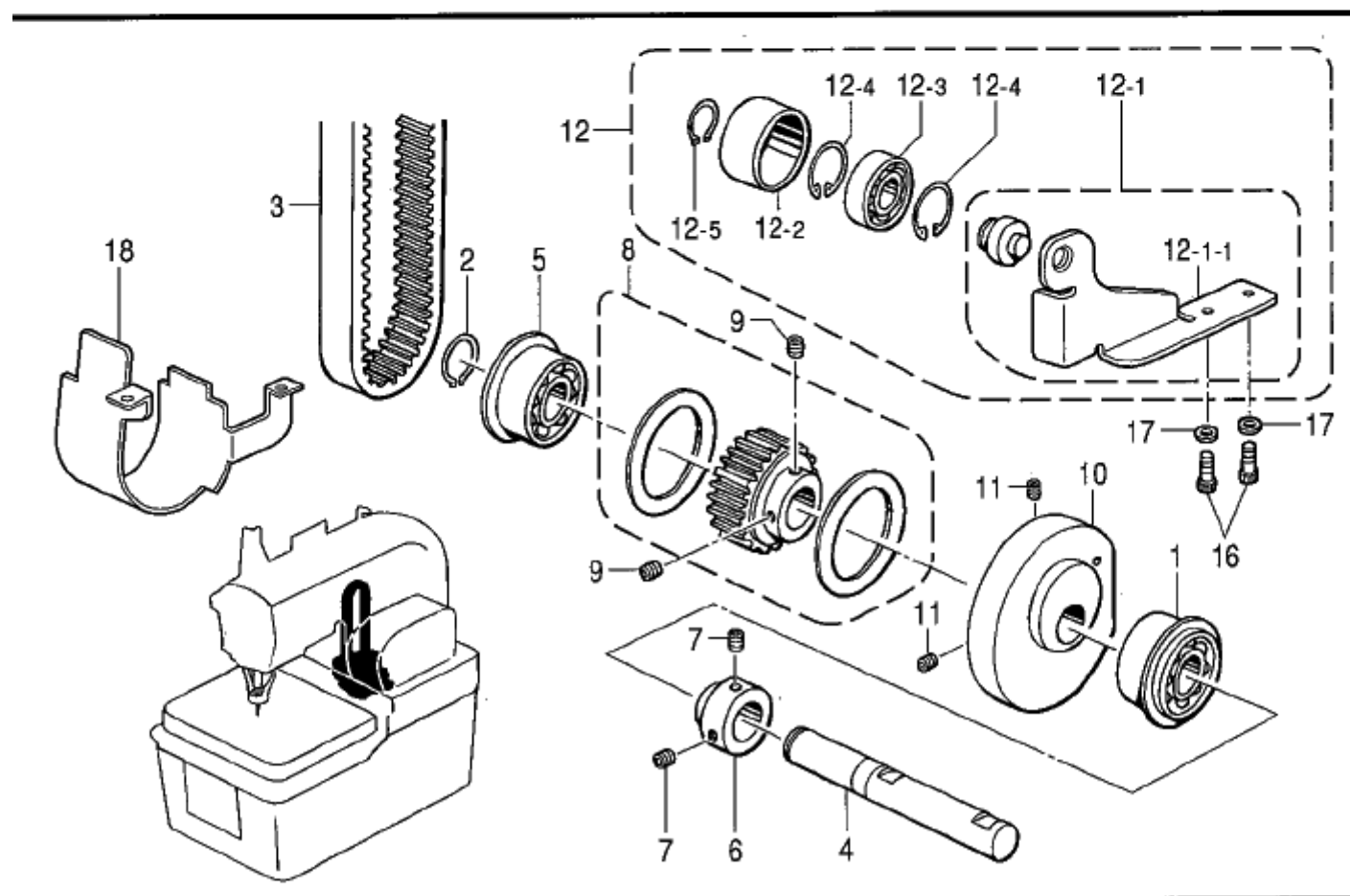

118-981-305

J. テンションプーリ関係 / Tension pulley mechanism

REF.NO	CODE	QTY	ヒンメイ	NAME OF PARTS	RM
1	S35112101	1	T7°-リクミ	TENSION PULLEY ASSY	
1-1	S35431101	1	T7°-リササエイタクミ	T-PULLEY SUPPORT PLATE ASSY	
1-2	S35110001	1	テンションプーリ	TENSION PULLEY	
1-3	048280242	2	トメワアサヨウC28	RETAINING RING, INTERNAL C28	
1-4	076001800	1	タマシクウケ6001ZZ	BALL-BEARING 6001ZZ(8482.10)	
1-5	048120142	1	トメワシクヨウC12	RETAINING RING, EXTERNAL C12	
2	018081622	2	アサホルト8X16	BOLT, SOCKET M8X16	
4	028080242	2	ハネサカネ2-8	WASHER, SPRING 2-8	
5	S35108001	1	アイトラフーリ	IDLER PULLEY	
6	076002800	2	タマシクウケ6002ZZ	BALL BEARING, 6002ZZ	
7	048320242	2	トメワアサヨウC32	RETAINING RING, INTERNAL C32	
10	S35107001	1	アイトラフーリシク	PULLEY SHAFT	
11	116920001	2	オクリシクスラストリング	RING, THRUST	
12	014060632	1	アサホルトM6X6	SET SCREW, SOCKET (CP) M6X6	
13	S35106001	1	ハットササシク	BED SUPPORT SHAFT	
14	014060632	1	アサホルトM6X6	SET SCREW, SOCKET (CP) M6X6	
17	S18707129	1	VベルトMシロ	BELT, VM ;WHITE	
18	S18707137	1	VベルトMシロ	BELT, VM ;WHITE	

118-981-126

K. 下軸関係 / Lower shaft mechanism

REF.NO	CODE	QTY	ヒンメイ	NAME OF PARTS	RM
1	076003850	1	タマシクウケ6003ZZ	BALL BEARING, 6003ZZ	
2	048150142	1	トメワシクヨウC15	RETAINING RING, EXTERNAL C15	
3	S35275100	1	タイミングベルト665	TIMING BELT, 665	
4	S35273001	1	シタシクカムシク	CAM SHAFT	
5	076202850	1	タマシクウケ6202ZZ	BALL BEARING, 6202ZZ	
6	S35274001	1	セツトカテー	SET SCREW COLLAR	
7	S23651001	2	アサヒ6X6ホソメ	SET SCREW, SOCKET (FT) M6X6	
8	S35272001	1	シタシクT7°-リクミ	TENSION PULLEY ASSY, ;L-SHAFT	
9	S23651001	2	アサヒ6X6ホソメ	SET SCREW, SOCKET (FT) M6X6	
10	S35270001	1	シタシクカム	LOWER SHAFT CAM	
11	S23651001	2	アサヒ6X6ホソメ	SET SCREW, SOCKET (FT) M6X6	
12	S35269101	1	テンションプーリクミ	TENSION PULLEY ASSY	
12-1	S35268101	1	テンションプーリウテクミ	ARM ASSY, ;T-PULLEY	
12-1-1	S35267101	1	テンションプーリウテ	ARM, ;T-PULLEY	
12-2	S35265001	1	テンションプーリ	TENSION PULLEY	
12-3	076001800	1	タマシクウケ6001ZZ	BALL-BEARING 6001ZZ(8482.10)	
12-4	048280242	2	トメワアサヨウC28	RETAINING RING, INTERNAL C28	
12-5	048120142	1	トメワシクヨウC12	RETAINING RING, EXTERNAL C12	
16	018502036	2	アサホルト5X20	BOLT, SOCKET M5X20	
17	025050232	2	ヒラサカネチエウ5	WASHER, PLAIN M 5	
18	S43376001	1	シタシクT7°-リカハ-	PULLEY COVER, ;L-SHAFT	

118-981-305

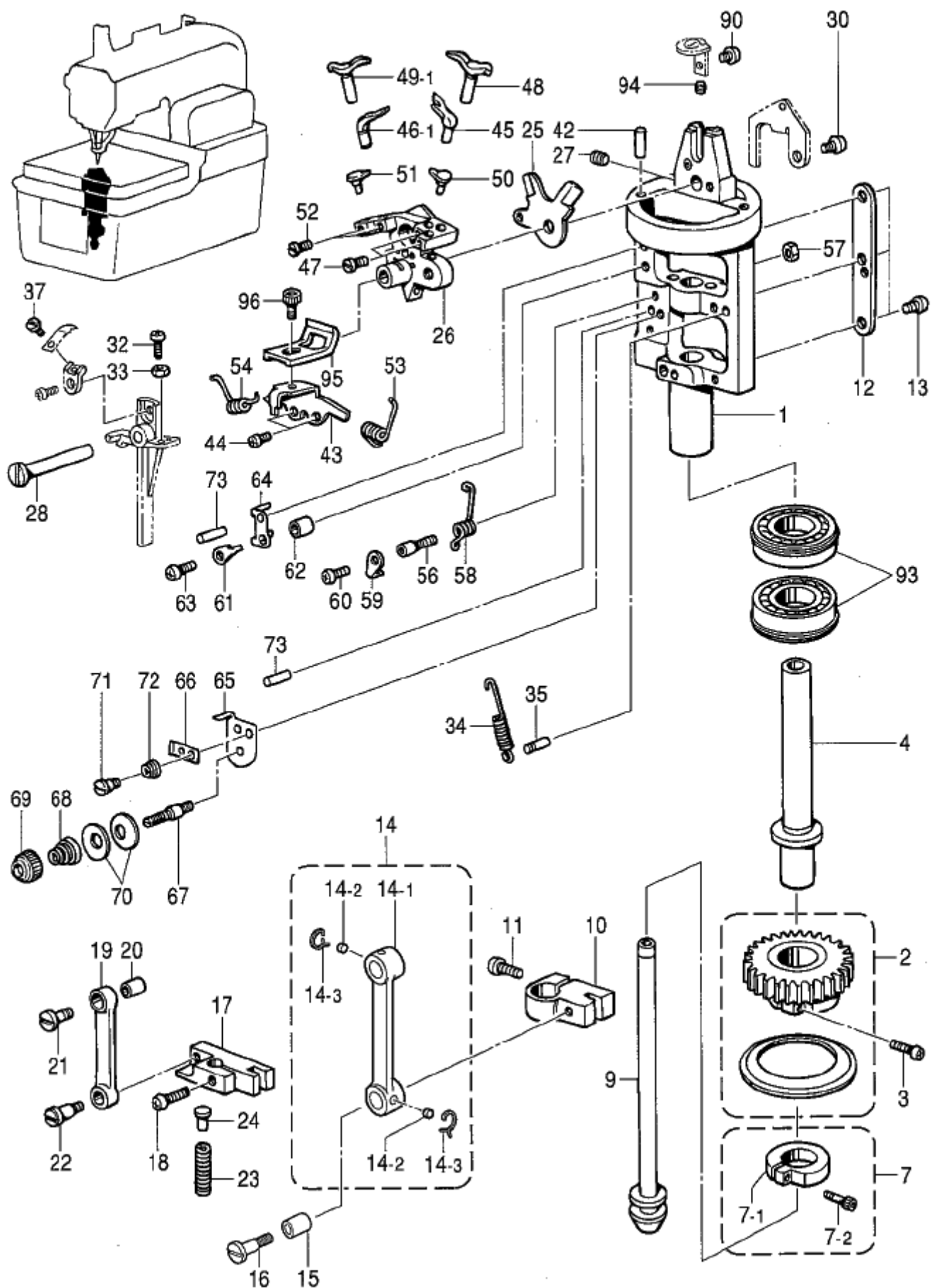

L1 . 二重環ルーバ関係 / Double chain stitch looper mechanism

REF.NO	CODE	Q'TY	ヒンメイ	NAME OF PARTS	RM
1	S34948101	1	レストタイ	LOOPER BASE	
2	S35007000	1	レスプーリクミ	LOOPER PULLEY ASSY	
3	062351615	1	ナハコ35X16	SCREW, PAN M3.5X16	
4	S35010001	1	ルーバークトウシク	DRIVING SHAFT, ;LOOPER	
7	S37432001	1	ハリホウフロクダキ	BLOCK CLAMP ASSY, ;N-BAR	
7-1	S35143001	1	ハリホウフロクダキ	BLOCK CLAMP, ;N-BAR	
7-2	018301632	1	アサホルト3X16	BOLT, SOCKET M3X16	
9	S35053001	1	スプレタリンクシク	LINK SHAFT, ;SPREADER	
10	S35011001	1	ルーバリンクシテン	LOOPER LINK CLAMP	
11	062501202	1	ナハコM5X12	SCREW, PAN M5X12	
12	S35012001	1	LSスライトアンナイ	LS-SLIDE GUIDE	
13	062300612	3	ナハコ3X6	SCREW, PAN M3X6	
14	S35015101	1	ルーバリンクソクミ	LOOPER LINK UNIT	
14-1	S52821001	1	ルーバリンククミ	LOOPER LINK ASSY	
14-2	S52832000	2	フェルト	FELT	
14-3	S52824001	2	フェルトオサエ	FELT SUPPORT	
15	SA0030001	2	ルーバリンクカラ	LOOPER LINK COLLAR	
16	SA0029001	2	ルーバリンクシメネジ	LOOPER LINK SCREW	
17	S35016001	1	スプレタリンクタイ	SPREADER LINK BASE	
18	062501202	1	ナハコM5X12	SCREW, PAN M5X12	
19	S35017001	1	スプレタカムリンク	CAM LINK, ;SPREADER	
20	S35018001	1	カムリンクカラ	COLLAR, ;CAM LINK	
21	S35014001	1	ダンネジM4	SHOULDER SCREW, M4	
22	S35019001	1	ダンネジM4	SHOULDER SCREW, M4	
23	S35020001	2	スプレタハネ	SPRING, COMPRESSION	
24	S35021000	2	スプレタハネアンナイ	SPRING GUIDE, ;SPREADER	
25	S35022101	1	スプレタサウカム	DRIVING CAM, ;SPREADER	
26	S35023001	1	LSホルダートタイ	LS-HOLDER BRACKET	
27	014060832	1	アサトメネジ6X8ホルミ	SCREW 6 X 8	
28	S35024101	1	ホルダサシク	SUPPORT SHAFT, ;HOLDER	
30	060400516	1	バインドM4X5	SCREW, BIND M4X5	
32	062301016	1	ナハコM3X10	SCREW, PAN M3X10	
33	021300302	1	3シユナツト3	NUT, 3 M3	
34	S35027001	1	ウイトキリハネ	SPRING, EXTENSION	
35	S35028000	1	ダウエルピン3X16	PIN, DOWEL 3X16	
37	105288001	1	シメネジ2.38	SCREW, SM2.38	
42	S35030001	1	イトアンナイハーフ	PIPE, ;TR-GUIDE	
43	S36860101	1	ハリウケササエ	SUPPORT, ;N-GUARD	
44	062300612	2	ナハコ3X6	SCREW, PAN M3X6	
45	S35410001	1	ルーバR	LOOPER, R	
46-1	S35411001	1	アイルーバ	EYE LOOPER	
47	S35032101	2	シメネジ2.6X5.5	SCREW, M2.6X5.5	
48	S35412101	1	スプレタR	SPREADER, R	
49-1	S35413101	1	スプレタL	SPREADER, L	
50	S35034001	1	スプレタストップR	STOPPER, R ;SPREADER	
51	S35033001	1	スプレタストップL	STOPPER, L ;SPREADER	
52	S35032101	2	シメネジ2.6X5.5	SCREW, M2.6X5.5	
53	S35035101	1	スプレタハネR	SPRING, TWIST ;R	
54	S35036101	1	スプレタハネL	SPRING, TWIST ;L	
56	S35037001	1	ハネアンナイシク	GUIDE SHAFT, ;SPRING	
57	021400202	1	2シユナツト4	NUT, 2 M4	
58	S35038001	1	イトリハネ	THREAD TAKE-UP SPRING	
59	S35039000	1	イトリハネササエ	SUPPORT, TR. TAKE-UP SPRING	
60	060300416	1	バインド3X4	SCREW, BIND M3X4	
61	S35040000	1	イトリハネアンナイ	SPRING GUIDE, ;L-TR TAKE-UP	
62	S35018001	1	カムリンクカラ	COLLAR, ;CAM LINK	
63	062401416	1	ナハコM4X14	SCREW, PAN M4X14	
64	S35041000	1	イトササエイタ	THREAD SUPPORT PLATE	
65	S35043001	1	イトササエタイ	L-THREAD PRESSER BASE	
66	S35042000	1	イトササエ	L-THREAD PRESSER	
67	S35044001	1	イト子ヨシホウ	L-TENSION STUD	

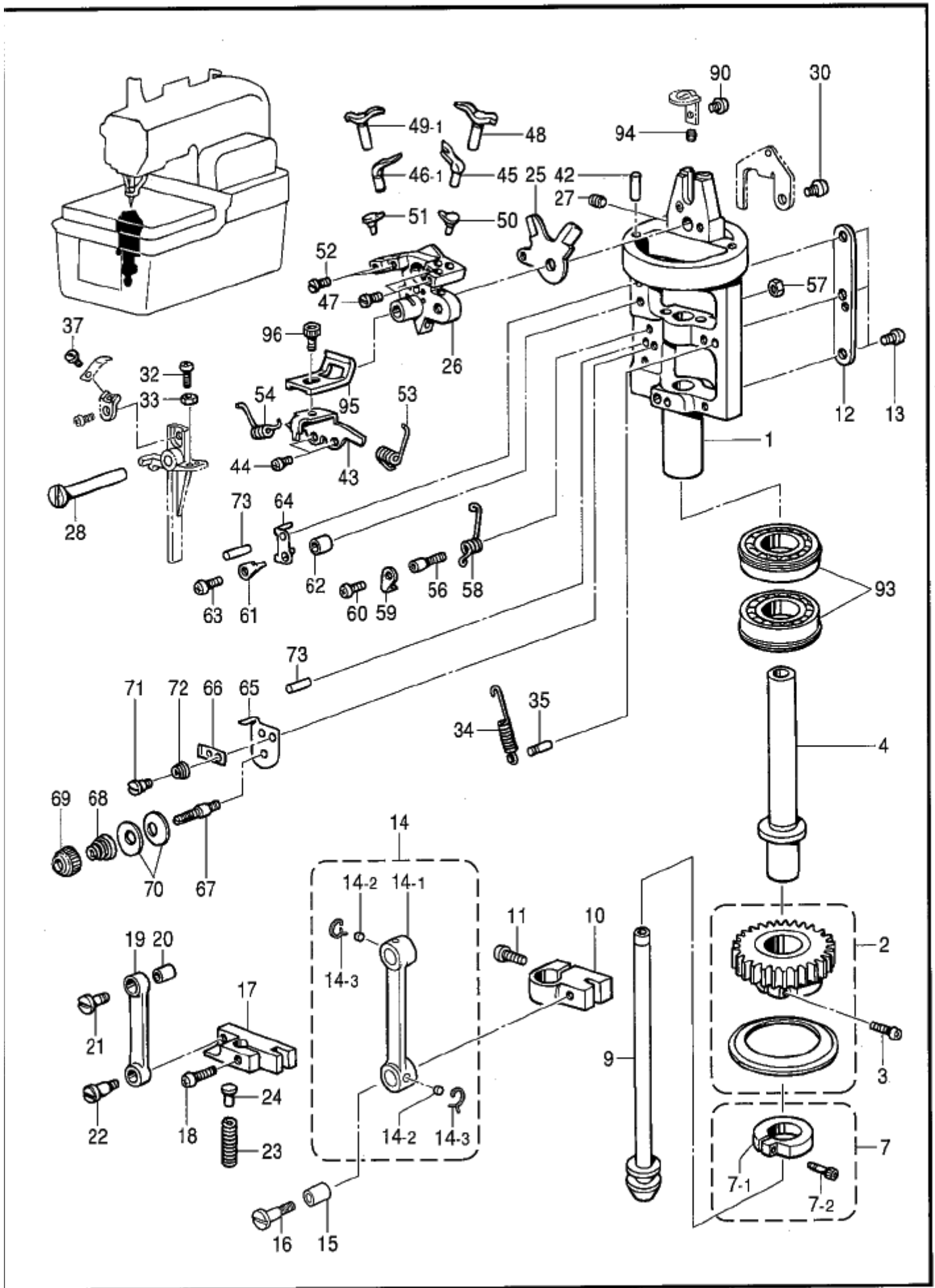

L1 . 二重環ルーバ関係 / Double chain stitch looper mechanism

REF.NO	CODE	QTY	品名	NAME OF PARTS	RM
68	154562001	1	プリテンションバネ	SPRING, B :PRE-TENSION	
69	155510001	1	バネ止	TENSION NUT	
70	144504001	2	ガイドディスク	DISC, THREAD GUIDE	
71	S35045001	1	タンスクリュー	SHOULDER SCREW, M3	
72	S35118001	1	バネ	TENSION SPRING	
73	S35046000	2	ニードルピン	NEEDLE PIN, 3X17.8	
90	S35326001	1	タンスクリュー	SCREW, M3.5	
93	076003850	2	ボールベアリング	BALL BEARING, 6003ZZ	
94	014300832	1	タンスクリュー	SET SCREW, SOCKET (CP) M3X8	
95	S36659001	1	ガード	NEEDLE GUARD, U	
96	018300532	1	タンスクリュー	BOLT, SOCKET M3X5	

< -00, 上糸切り用 / For -00, Upper thread trimmer >

< -01, 上下糸切り用 / For -01, Upper & lower thread trimmer >

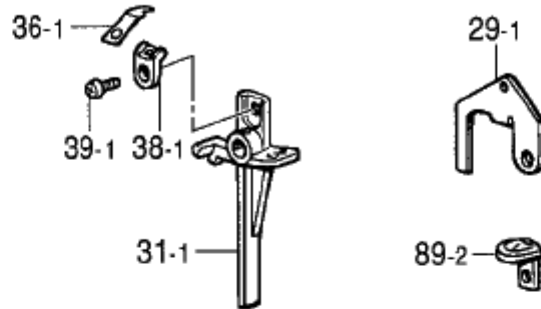

< -02, ジーンズ仕様 / For -02, Jeans specification >

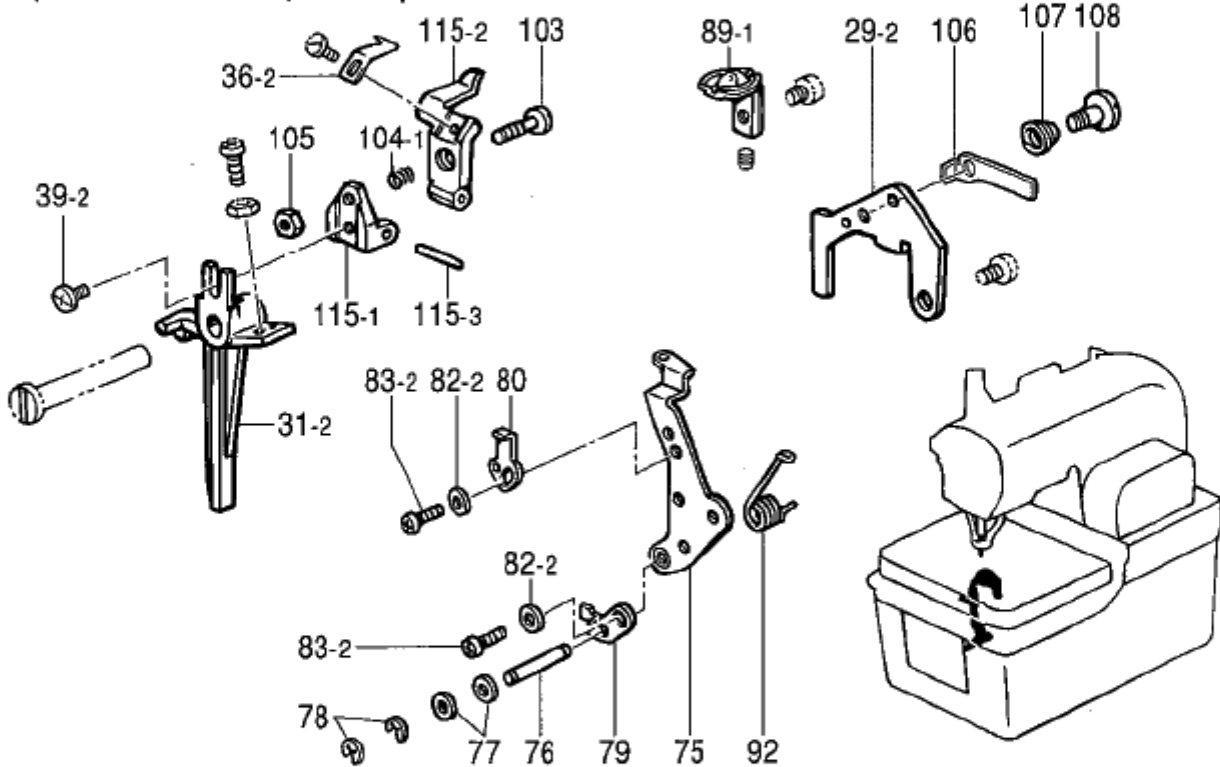

< -01, 上下糸切り用 / For -01, Upper & lower thread trimmer >

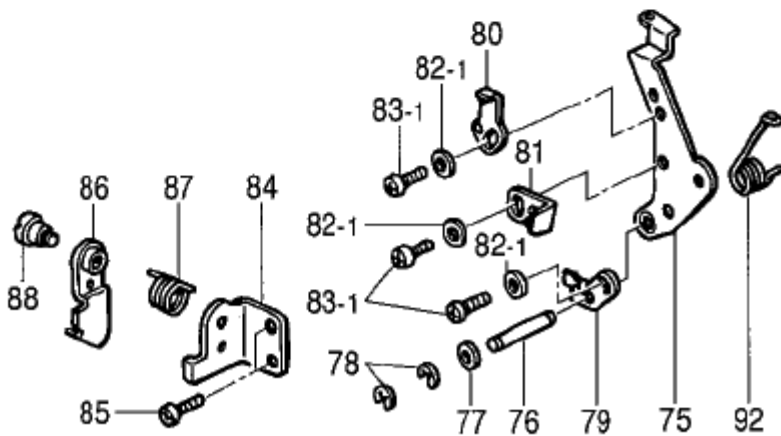

" オプション部品
/ OPTION PARTS "

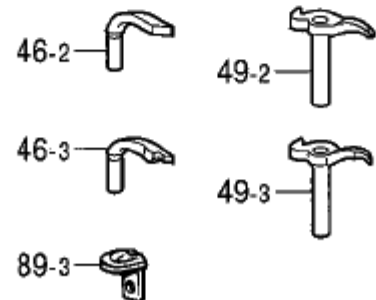

L2 . 二重環ルーバ関係 / Double chain stitch looper mechanism

REF.NO	CODE	Q'TY	品名	NAME OF PARTS	RM
			<-00, 上糸切り用>	<For-00, Upper thread trimmer>	
			<-01, 上下糸切り用>	<For-01, Upper & lower thread trimmer>	
29-1	S35054001	1	シフト案内C	GIMP GUIDE, C	
31-1	S35025001	1	トリムレバーブレイク	THREAD TRIMMER LEVER BRACKET	
36-1	S35029001	1	ウイトカハ	MOVABLE KNIFE, A ;UPPER	
38-1	S35026001	1	ウイトカハ	BRACKET, ;U-MOVABLE KNIFE	
39-1	060300416	1	バインド3X4	SCREW, BIND M3X4	
89-2	S47033001	1	スロートプレート1.6	THROAT PLATE, 1.6	
			<-02, ジーンズ仕様>	<For-02, jeans specification>	
29-2	S37696101	1	シフト案内C-J	GIMP GUIDE, C-J	
31-2	S37726001	1	トリムレバーブレイクB	T-TRIMMER LEVER BRACKET, B	
36-2	S37723001	1	ウイトカハB	MOVABLE KNIFE, B ;UPPER	
39-2	060350616	1	バインド3.5X6	SCREW, BIND M3.5X6	
75	S35048101	1	トルメレバー	TENSION RELEASE LEVER	
76	S35049001	1	トルメレバーシャフト	LEVER SHAFT, ;T-RELEASE	
77	025680132	2	ワッシャー4.37	WASHER, PLAIN S 4.37	
78	048030342	2	リングE3	RETAINING RING, E3	
79	S35050001	1	ルーパーテンションレバー	LOOPER TENSION RELEASE	
80	S35051001	1	トルメレバープレート	TENSION RELEASE PLATE	
82-2	025350236	2	ワッシャーM3.5	WASHER, PLAIN M 3.5	
83-2	062350516	2	ネジM3.5X5	SCREW, PAN M3.5X5	
89-1	S37752001	1	スロートプレート1.8-J	THROAT PLATE, 1.8-J	
92	S35057001	1	トルメレバーバネ	SPRING, TWIST	
103	S37724001	1	ネジSM2.38	SCREW, SM2.38	
104-1	S37725001	1	圧縮バネ	SPRING, COMPRESSION	
105	S47932001	1	ナット238-56	NUT, SM2.38-56	
106	S41252000	1	シフト案内プレート-J	GIMP THREAD CLAMP PLATE, J	
107	S35118001	1	テンションバネ	TENSION SPRING	
108	159113001	1	肩部ネジ3.18	SHOULDER SCREW, SM3.18	
115	S47512001	1	下部糸押し機構	LOWER THREAD PRESSER ASSY, J	
115-1	S37721001	1	下部糸押しブラケット	LOWER THREAD PRESSER BRACKET	
115-2	S37720001	1	下部糸押し	LOWER THREAD PRESSER	
115-3	148407001	1	ピンL	DOWEL PIN, L	
			<-01, 上下糸切り用>	<For-01, Upper & lower thread trimmer>	
75	S35048101	1	トルメレバー	TENSION RELEASE LEVER	
76	S35049001	1	トルメレバーシャフト	LEVER SHAFT, ;T-RELEASE	
77	025680132	2	ワッシャー4.37	WASHER, PLAIN S 4.37	
78	048030342	2	リングE3	RETAINING RING, E3	
79	S35050001	1	ルーパーテンションレバー	LOOPER TENSION RELEASE	
80	S35051001	1	トルメレバープレート	TENSION RELEASE PLATE	
81	S35365101	1	トルメレバークロー	TENSION RELEASE LEVER CLAW	
82-1	025350236	3	ワッシャーM3.5	WASHER, PLAIN M 3.5	
83-1	062350516	3	ネジM3.5X5	SCREW, PAN M3.5X5	
84	S35366001	1	トルメレバークローサポート	TENSION RELEASE CLAW SUPPORT	
85	062400812	2	ネジM4X8	SCREW, PAN M4X8	
86	S35052001	1	トルメレバークロー	TENSION RELEASE CLAW	
87	S35055001	1	トルメレバーバネ	SPRING, TWIST	
88	S35056001	1	肩部ネジM4	SHOULDER SCREW, M4	
92	S35057001	1	トルメレバーバネ	SPRING, TWIST	
			"オプション部品"	"OPTION PARTS"	
46-2	S35471001	1	アイルーパーB <太糸用>	EYE LOOPER, B.....<For heavy-weight thread>	
46-3	S49078001	1	ルーパーL-S <単環用>	LOOPER, L-S.....<For chain stitch>	
49-2	S35472101	1	スプレッドャーLB <太糸用>	SPREADER, LB.....<For heavy-weight thread>	
49-3	S49079001	1	スプレッドャーL-S <単環用>	SPREADER, L-S.....<For chain stitch>	
89-3	S47034001	1	スロートプレート1.1 <小穴用>	THROAT PLATE, 1.1.....<For small hole>	

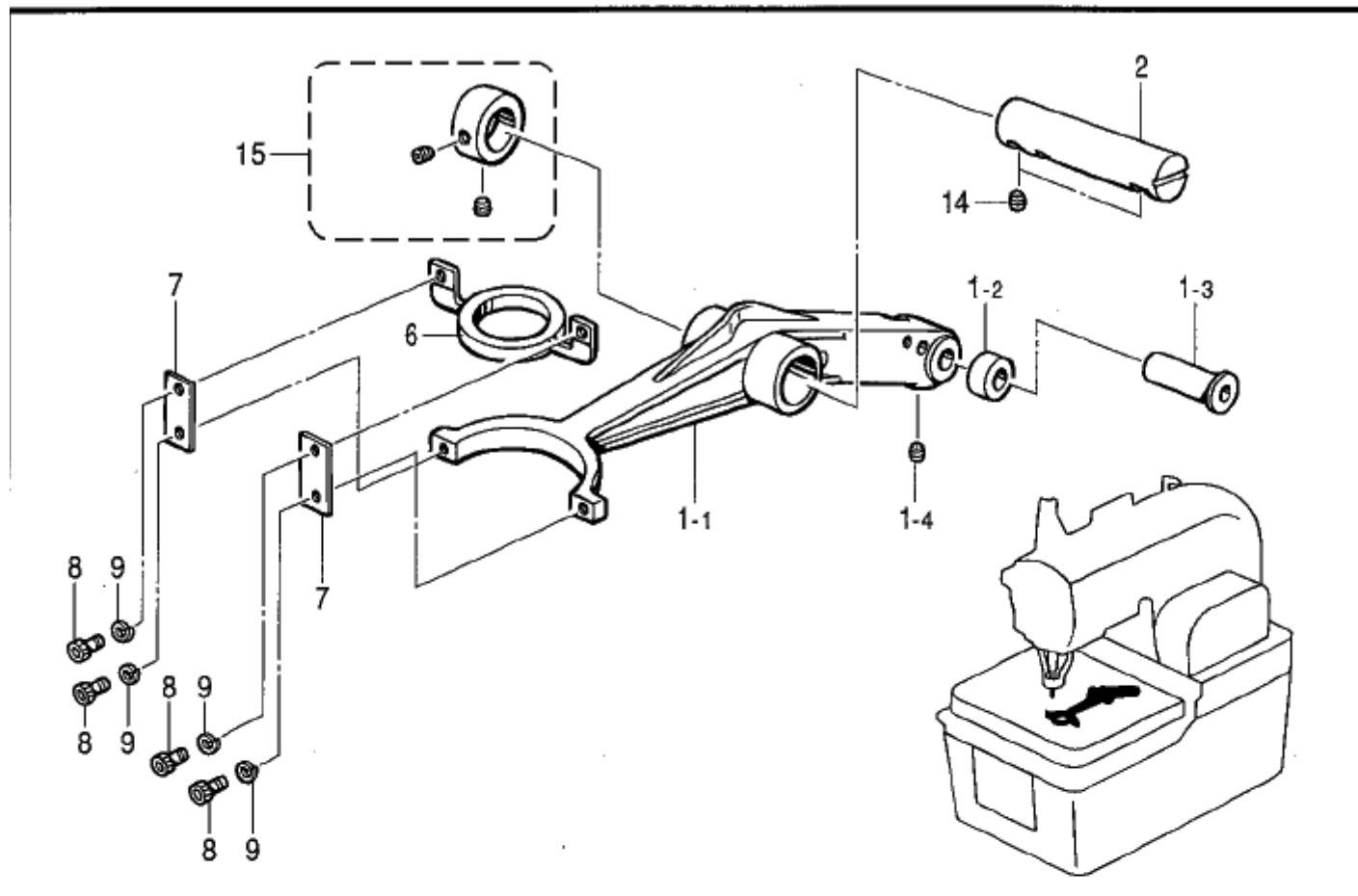

118-981-306

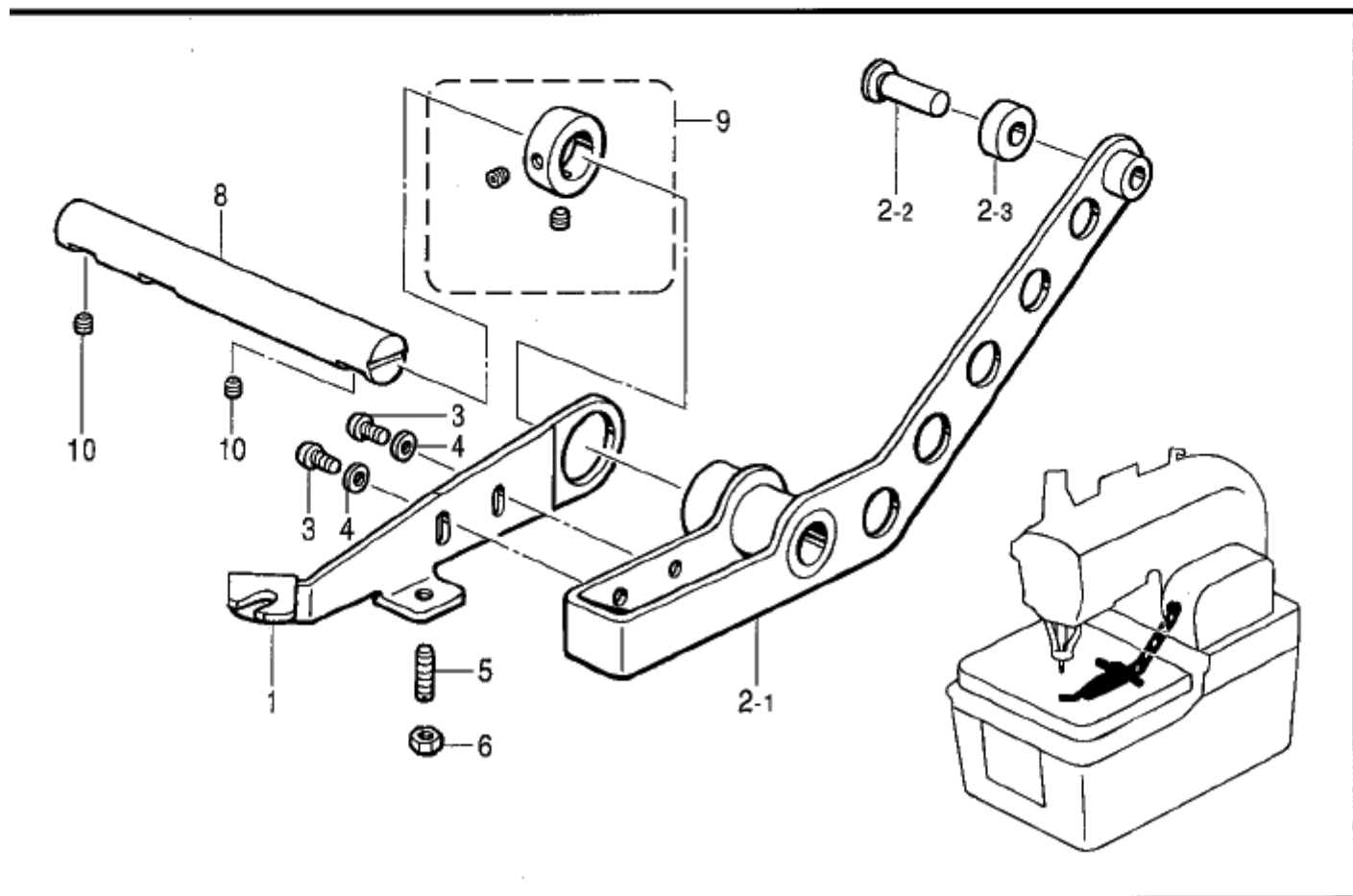

118-981-310

M.ルーパ-関係 / Looper mechanism

REF.NO	CODE	QTY	ヒンメイ	NAME OF PARTS	RM
1	S35066001	1	ル-ハ°リンククミ	LOOPER LINK ASSY	
1-1	S35067001	1	ル-ハ°-リンク	LOOPER LINK	
1-2	S35063001	1	ル-ハ°カムコロ	CAM ROLLER, ;LOOPER	
1-3	S35064001	1	ル-ハ°カムコロピン	ROLLER PIN, ;L-CAM	
1-4	014060632	1	アナクホ°ミ6X6	SET SCREW, SOCKET (CP) M6X6	
2	S35065001	1	ル-ハ°-リンクササエシク	SUPPORT SHAFT, ;L-LINK	
6	S35062001	1	ル-ハ°サト°ウタイ	LOOPER DRIVING PLATE	
7	S35061000	2	ル-ハ°リンクハ°ネ	SPRING, PLATE	
8	S10439001	4	アナホ°ルト3X6	BOLT, SOCKET M3	
9	028030242	4	ハ°ネサ°カ°ネ2-3	WASHER, SPRING 2-3	
14	014060632	2	アナクホ°ミ6X6	SET SCREW, SOCKET (CP) M6X6	
15	S23612051	1	セツトカラークミ	SET SCREW COLLAR ASSY	

118-981-306

N.スプレダ-関係 / Double chain stitch looper mechanism

REF.NO	CODE	QTY	ヒンメイ	NAME OF PARTS	RM
1	S35073001	1	スプレタ°-クト°ウレハ°-	SPREADER DRIVING LEVER	
2	S35072101	1	スプレタ°-レハ°-クミ	SPREADER LEVER ASSY	
2-1	S35071001	1	スプレタ°-カムレハ°-	CAM LEVER, ;SPREADER	
2-2	S35070101	1	スプレタ°-カムコロピン	ROLLER PIN, ;SPREADER CAM	
2-3	S35069001	1	スプレタ°-カムコロ	ROLLER, ;SPREADER CAM	
3	062400812	2	ナハ°コ4X8	SCREW, PAN M4X8	
4	025040232	2	ヒラサ°カ°ネチユウ4	WASHER, PLAIN M 4	
5	S35068001	1	トメネシ°M3.5	SET SCREW, M3.5	
6	021350106	1	1シユナツト35	NUT, 1 M3.5	
8	S35065001	1	ル-ハ°-リンクササエシク	SUPPORT SHAFT, ;L-LINK	
9	S23612051	1	セツトカラークミ	SET SCREW COLLAR ASSY	
10	014060632	2	アナクホ°ミ6X6	SET SCREW, SOCKET (CP) M6X6	

118-981-310

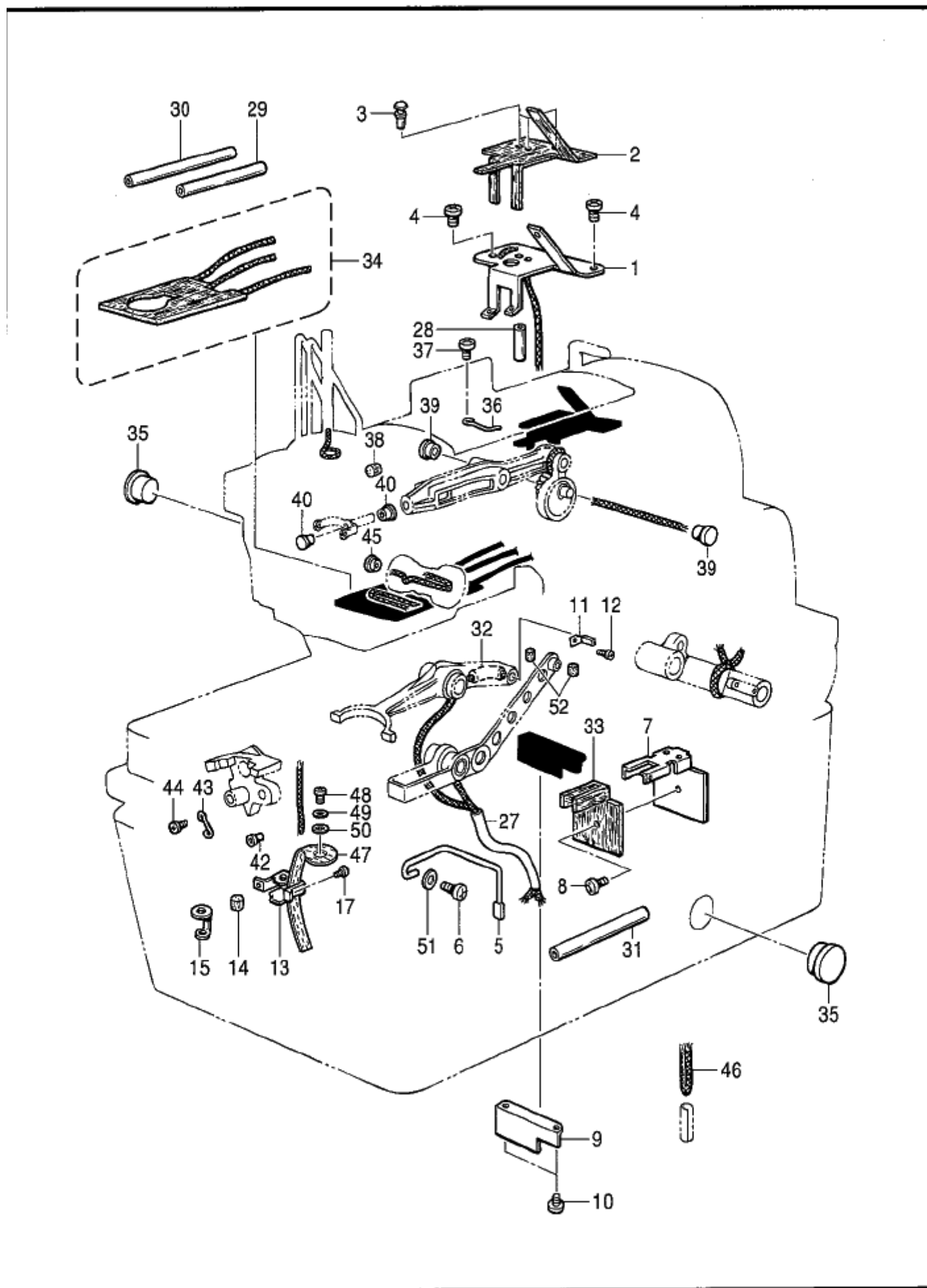

P. 給油潤滑関係 / Lubrication

REF.NO	CODE	Q'TY	ヒンメイ	NAME OF PARTS	RM
1	S35003201	1	トウシサII	WICK SUPPORT, L	
2	S35002100	1	トウシサIIフェルト	FELT	
3	S35001000	5	ナイロンハット	NYLON RIVET	
4	062350616	2	ナハコM3.5X6	SCREW, PAN M3.5X6	
5	S43724001	1	ルハオイルアンナイ	OIL GUIDE, ;LOOPER	
6	062401212	1	ナハコM4X12	SCREW, PAN M4X12	
7	S34999001	1	トウシサID	WICK SUPPORT, D	
8	062400616	2	ナハコM4X6	SCREW, PAN M4X6	
9	S34998001	1	シタシカムカバー	COVER, ;L-SHAFT CAM	
10	062400616	2	ナハコM4X6	SCREW, PAN M4X6	
11	S34997001	1	ルハトウシサI	WICK SUPPORT, ;LOOPER	
12	062300416	1	ナハコM3X4	SCREW, PAN M3X4	
13	S34996001	1	レースフェルトI	FELT SUPPORT	
14	113006001	1	フェルト	FELT	
15	S34995000	1	レースフェルトA	FELT	
17	062300416	1	ナハコM3X4	SCREW, PAN M3X4	
27	S34986000	1	ビニルチューブ	OIL TUBE, L=135	
28	S34985000	1	ビニルチューブ	OIL TUBE, L=90	
29	S34984000	1	ビニルチューブ	OIL TUBE, L=150	
30	S34983000	1	ビニルチューブ	OIL TUBE, L=160	
31	S34982000	1	ビニルチューブ	OIL TUBE, L=70	
32	S34981000	1	ビニルチューブ	OIL TUBE, L=50	
33	S34980000	1	フェルト	FELT	
34	S34979100	1	フェルトクミ	FELT ASSY	
35	152948001	2	オイルホットマト	OIL WINDOW	
36	117150001	2	コードササIカネ	CORD HOLDER	
37	062350616	2	ナハコM3.5X6	SCREW, PAN M3.5X6	
38	S34974000	3	ロフトフェルト	FELT	
39	143196001	2	オイルニカシグチ	OIL CAP	
40	143196001	2	オイルニカシグチ	OIL CAP	
42	S34972000	1	ビニルチューブ	OIL TUBE	
43	S34971001	1	クミヒモササI	WICK SUPPORT	
44	060300416	1	ハイント3X4	SCREW, BIND M3X4	
45	143196001	1	オイルニカシグチ	OIL CAP	
46	S37173000	1	クミヒモ3X3	WICK, 3X3 L=50	
47	S43880000	1	レースフェルトB	FELT, B	
48	062350616	1	ナハコM3.5X6	SCREW, PAN M3.5X6	
49	025350332	1	ヒラサカネタ13.5	WASHER, PLAIN L 3.5	
50	105248003	1	サカネ	WASHER	
51	025040332	1	ヒラサカネタ14	WASHER, PLAIN L 4	
52	112754001	2	フェルト	FELT	

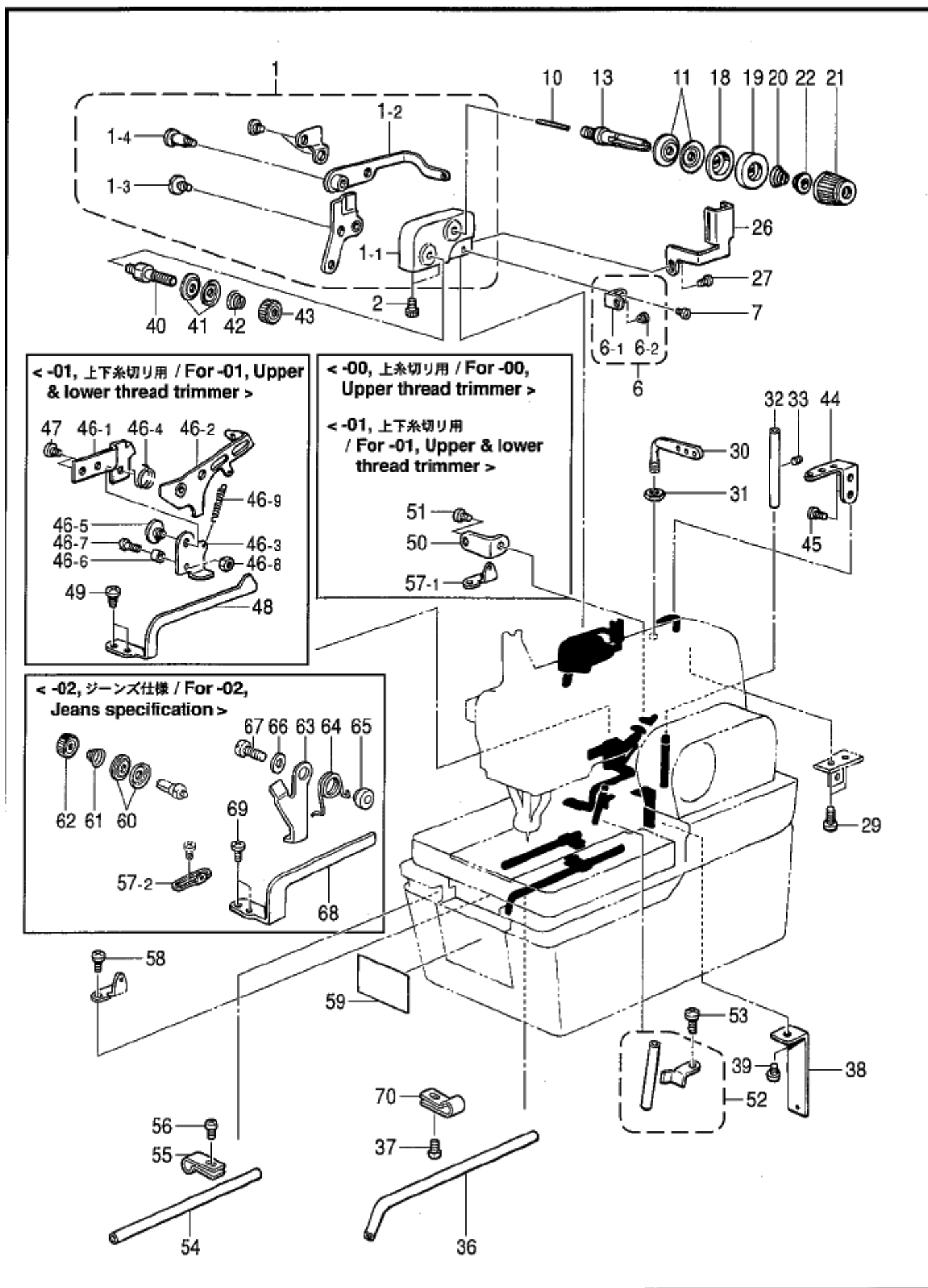

Q. 糸通し関係 / Threading mechanism

REF.NO	CODE	Q'TY	品名	NAME OF PARTS	RM
1	S37874101	1	ウイトテンションタイクミ	U-THREAD TENSION BRACKET ASSY	
1-1	S34917001	1	ウイトテンションタイ	U-THREAD TENSION BRACKET	
1-2	S34918101	1	ウイトトリレバークミ	U-THREAD TAKE-UP LEVER ASSY	
1-3	S34966001	1	ダンネジ M4	SHOULDER SCREW, M4	
1-4	S34922101	1	ダンネジ M4	SHOULDER SCREW, M4	
2	018401236	2	アソボ M4X12	BOLT, SOCKET M4X12	
6	146926001	1	トアンナイクミ	THREAD GUIDE ASSY	
6-1	146927001	1	トアンナイ	THREAD GUIDE	
6-2	146924000	1	スワブ プッシュ	THREAD BUSH	
7	062350616	1	ハコ M3.5X6	SCREW, PAN M3.5X6	
10	159220101	1	トユルピン	TENSION RELEASE PIN	
11	145446001	2	トチヨウシヤ	DISC, TENSION	
13	S34923001	1	ウイトチヨウシヤウ	TENSION STUD, U-THREAD	
18	159805001	1	トチヨウシヤオサエ	DISC PRESSER, TENSION	
19	144103009	1	トチヨウシヤオサエ	DISC PRESSER, TENSION	
20	159221001	1	トチヨウシヤネ	TENSION SPRING	
21	S20682102	1	トチヨウシヤツト	TENSION NUT, GREEN	
22	S20681000	1	チヨウシヤネウサガネ	WASHER	
26	S34924001	1	ウイトトリレバークミ	LEVER GUIDE	
27	062350616	1	ハコ M3.5X6	SCREW, PAN M3.5X6	
29	062400812	2	ハコ M4X8	SCREW, PAN M4X8	
30	S35466001	1	ミツメイトカケ	THREAD RETAINER	
31	021060306	1	3 ヌナツト	NUT, 3 M6	
32	150644009	1	トアンナイパイプ S	THREAD GUIDE PIPE, S	
33	012400636	1	アセラ M4X6	SET SCREW, SOCKET (FT) M4X6	
36	S43723001	1	シタイトアンナイパイプ A	GUIDE PIPE, A; L-THREAD	
37	062400612	1	ハコ M4X6	SCREW, PAN M4X6	
38	S34928001	1	トアンナイ B	THREAD GUIDE, B	
39	062400612	1	ハコ M4X6	SCREW, PAN M4X6	
40	S20698121	1	トチヨウシヤウ	TENSION STUD	
41	144504001	2	トアンナイシヤ	DISC, THREAD GUIDE	
42	154562001	1	プレテンションネジ	SPRING, B:PRE-TENSION	
43	155510001	1	トチヨウシヤツト	TENSION NUT	
44	152889001	1	ミツメイトカケ	THREAD RETAINER	
45	062670616	2	ハコ M3.57-40X6	SCREW, PAN SM3.57-40X6	
			<-01, 上下糸切り用>	<For-01, Upper & lower thread trimmer>	
46	S34944101	1	シタイトトリレバークミ	GIMP THREAD TAKE-UP LEVER ASSY	
46-1	S34936001	1	シタイトササエ	SUPPORT PLATE, G-THR TAKE-UP	
46-2	S34937001	1	シタイトトリレバークミ	GIMP THREAD TAKE-UP LEVER	
46-3	S34938101	1	シタイトササエ	DRIVING PLATE, G-THR TAKE-UP	
46-4	S34940001	1	シタイトトリレバークミ	GIMP THREAD TAKE-UP SPRING	
46-5	S34941001	1	ダンネジ M4	SHOULDER SCREW, M4	
46-6	S35018001	1	カムリンクカラー	COLLAR, CAM LINK	
46-7	S34943001	1	ダンネジ M4	SHOULDER SCREW, M4	
46-8	021400106	1	ナツト M4	NUT, 1 M4	
46-9	S35428001	1	ササエ	SPRING, EXTENSION	
47	062400812	2	ハコ M4X8	SCREW, PAN M4X8	
48	S34939001	1	シタイトアンナイ	GUIDE, G-THREAD TAKE-UP	
49	062400812	2	ハコ M4X8	SCREW, PAN M4X8	
			<-00, 上糸切り用>	<For-00, Upper thread trimmer>	
			<-01, 上下糸切り用>	<For-01, Upper & lower thread trimmer>	
50	S34942001	1	シタイトアンナイ	THREAD GUIDE, GIMP	
51	062400812	1	ハコ M4X8	SCREW, PAN M4X8	
57-1	S35430001	1	シタイトアンナイ B	THREAD GUIDE, B; GIMP	
52	S34934001	1	シタイトアンナイクミ	GIMP THREAD GUIDE ASSY, S	
53	062400812	1	ハコ M4X8	SCREW, PAN M4X8	
54	S20695001	1	DLイトアンナイパイプ	THREAD GUIDE PIPE	
55	S20696001	1	トアンナイパイプササエ	PIPE SUPPORT, TR-GUIDE	

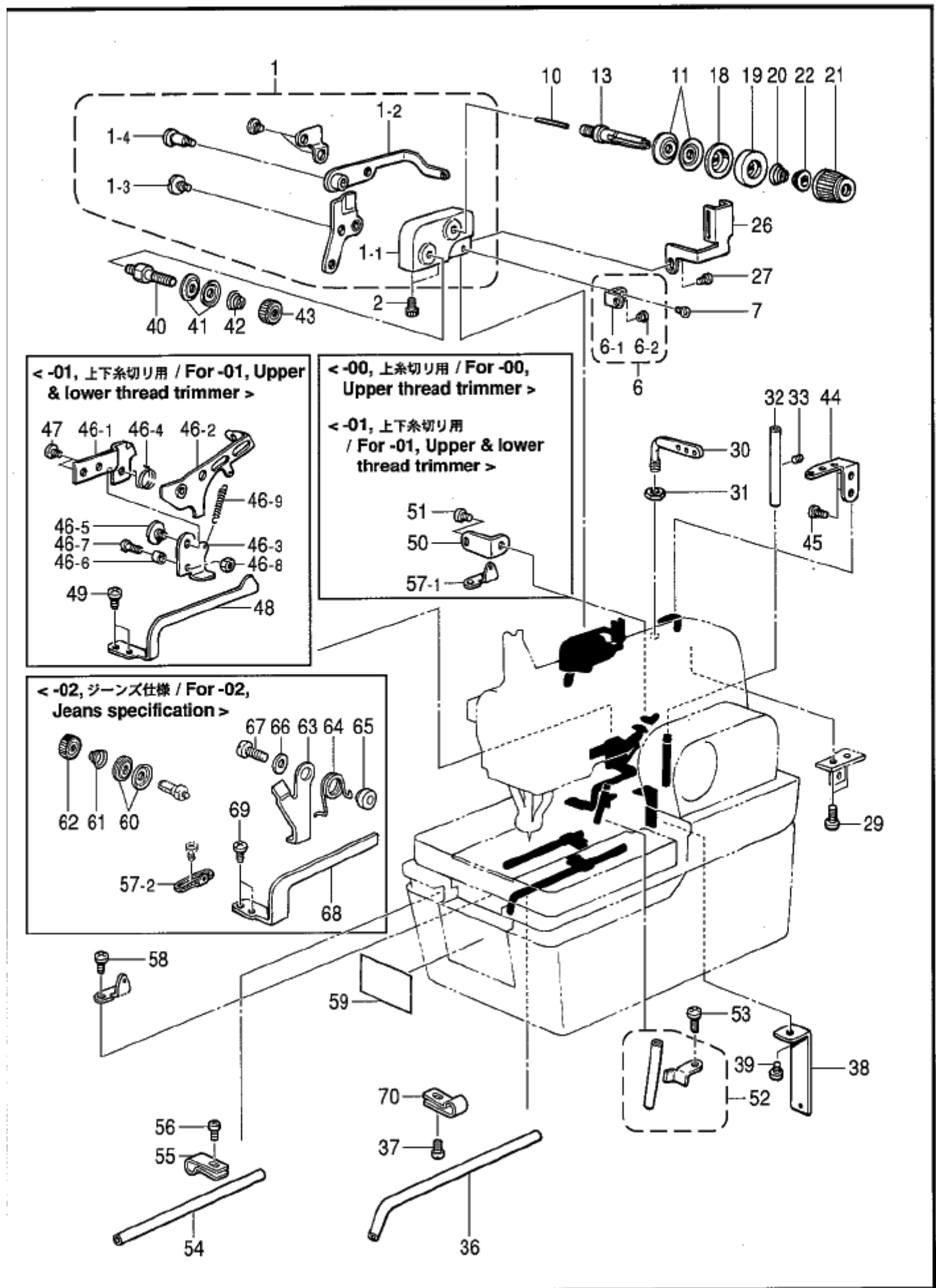

Q . 糸通し関係 / Threading mechanism

REF.NO	CODE	QTY	ヒンメイ	NAME OF PARTS	RM
56	062400812	2	ナ ^ハ 34X8	SCREW, PAN M4X8	
58	062400812	1	ナ ^ハ 34X8	SCREW, PAN M4X8	
59	S35912001	1	1 糸通し図	THREADING DIAGRAM	
70	S20696001	1	1 糸通しガイド	PIPE SUPPORT, ;TR-GUIDE	
			<-02, ジーンズ仕様>	<For-02, jeans specification>	
57-2	S37697001	1	1 糸通しガイド	THREAD GUIDE, J ;GIMP	
60	144504001	2	2 糸通しディスク	DISC, THREAD GUIDE	
61	154562001	1	1 プリテンションバネ	SPRING, B :PRE-TENSION	
62	155510001	1	1 糸通しナット	TENSION NUT	
63	S51219001	1	1 糸通しリリースプレート	TENSION RELEASE PLATE, ;GIMP	
64	S37749001	1	1 糸通しリリースバネ	SPRING, TWIST	
65	S51220001	1	1 カラ	COLLAR	
66	025040332	1	1 ヒラサ ^カ 4	WASHER, PLAIN L 4	
67	062401212	1	1 ナ ^ハ 34X12	SCREW, PAN M4X12	
68	S37750001	1	1 糸通しガイド	TR TAKE-UP GUIDE, J ;GIMP	
69	062400812	2	2 ナ ^ハ 34X8	SCREW, PAN M4X8	

< -01, 上下糸切り用 / For -01, Upper & lower thread trimmer >

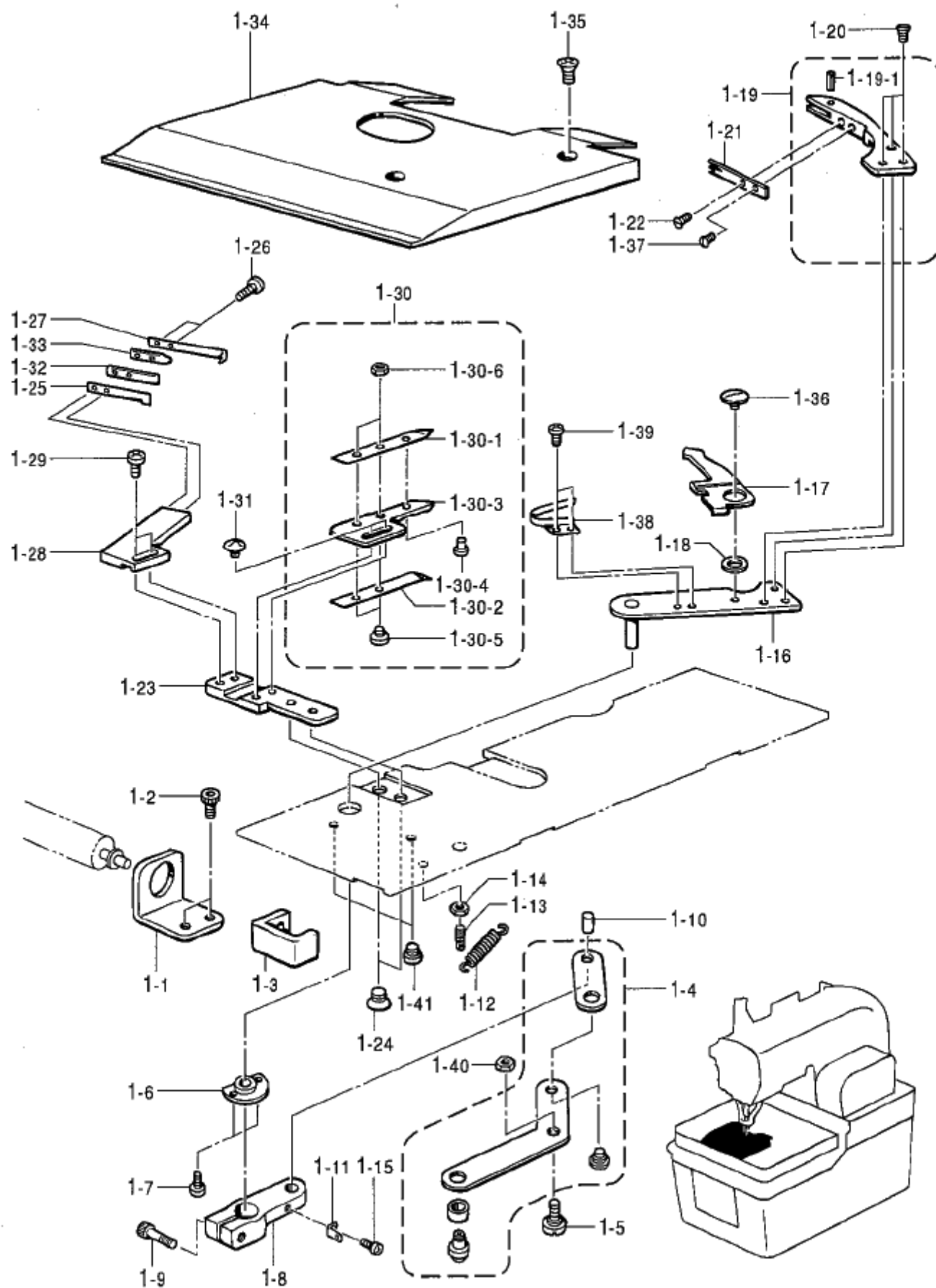

R1 . 糸切り関係 / Thread trimmer mechanism

REF.NO	CODE	Q'TY	ヒンメイ	NAME OF PARTS	RM
			<-01, 上下糸切り用>	<For-01, Upper & lower thread trimmer>	
1-1	S34914001	1	トキリリシタ サイタ	SUPPORT PLATE, ;CYLINDER	
1-2	018400832	2	アホ 母4X8	BOLT, SOCKET M4X8	
1-3	S34913001	1	トキリリシタ ツメ	THREAD TRIMMER CYLINDER CLAW	
1-4	S34910101	1	トキリリシタ ハークミ	THREAD TRIMMER LINK LEVER ASSY	
1-5	S34881001	1	タンネシ M4	SHOULDER SCREW, M4	
1-6	S34906100	1	トキリシタ 母	BUSH, ;TR TRIMMER ARM	
1-7	062260612	2	ナハ コ2.6X6	SCREW, PAN M2.6X6	
1-8	S34905101	1	トキリシタ ハーク	THREAD CUTTER LEVER ARM	
1-9	018401032	1	アホ 母4X10	BOLT, SOCKET M4X10	
1-10	S37858000	1	ニト 此 4X8	NEEDLE PIN, 4X8	
1-11	S34903001	1	ハネカ	SPRING HOOK	
1-12	S34883001	1	トキリハネ	SPRING, EXTENSION	
1-13	S34902001	1	ハネカ	SPRING HOOK	
1-14	021350106	1	シユナツト35	NUT, 1 M3.5	
1-15	062260406	1	ナハ コ2.6X4	SCREW, PAN M2.6X4	
1-16	S34901001	1	トキリシタ	THREAD TRIMMER ARM	
1-17	S34900001	1	トツカミ オープナー	OPENER, ;T-NIPPER	
1-18	153219001	1	トウハカラ	COLLAR, ;MOVABLE KNIFE	
1-19	S34899001	1	トウハクミ	MOVABLE KNIFE ASSY	
1-19-1	S34898001	1	スプリング ヒン1.4	PIN, SPRING 1.4	
1-20	141542001	3	サラネシ 3.18	SCREW 3.18	
1-21	S34897001	1	トサハキ	THREAD HANDLER	
1-22	S01694001	1	サラネシ 2.38X4	SCREW, FLAT SM2.38X4	
1-23	S34896001	1	コテイハタ	BRACKET, ;FIXED KNIFE	
1-24	061300416	2	サラコM3X4	SCREW, FLAT M3X4	
1-25	S34895001	1	コテイハ	FIXED KNIFE	
1-26	018260832	2	アホ 母2.6X8	BOLT, SOCKET M2.6X8	
1-27	S34894001	1	トアンナイタ	THREAD GUIDE PLATE	
1-28	S34893001	1	コテイハトリツケタ	SETTING BRACKET, ;FIXED KNIFE	
1-29	062300512	2	ナハ コ3X5	SCREW, PAN M3X5	
1-30	S34889101	1	トツカミ	THREAD NIPPER ASSY	
1-30-1	S34890001	1	トツカミU	THREAD NIPPER, U	
1-30-2	S34891101	1	トツカミD	THREAD NIPPER, D	
1-30-3	S34888101	1	トツカミM	THREAD NIPPER, M	
1-30-4	S34892001	1	トツカミ オープナー ヒン	OPENER PIN	
1-30-5	062020416	2	ナハ コ2X4	SCREW, PAN M2X4	
1-30-6	021020106	2	ナツト1シユ2	NUT	
1-31	542515001	2	シメネシ 2.6X3.5	SCREW, M2.6X3.5	
1-32	S34887001	1	コテイハオサエハネ	SPRING, PLATE ;F-KNIFE	
1-33	S34886001	1	コテイハオサエハネU	SPRING, U PLATE ;F-KNIFE	
1-34	S34885001	1	オサエプレートU	PRESSER PLATE, U	
1-35	004401003	2	サラネシ 4X10	SCREW, FLAT M4X10	
1-36	152904001	1	シメネシ 4.37	SCREW, SM4.37	
1-37	104336003	1	シメネシ 2.38	SCREW, SM2.38	
1-38	S34884000	1	オープナーハネ	OPENER SPRING	
1-39	060630312	2	ハイント 238-56X3	SCREW, BIND SM2.38X3	
1-40	021400202	1	シユナツト4	NUT, 2 M4	
1-41	062300416	2	ナハ コM3X4	SCREW, PAN M3X4	

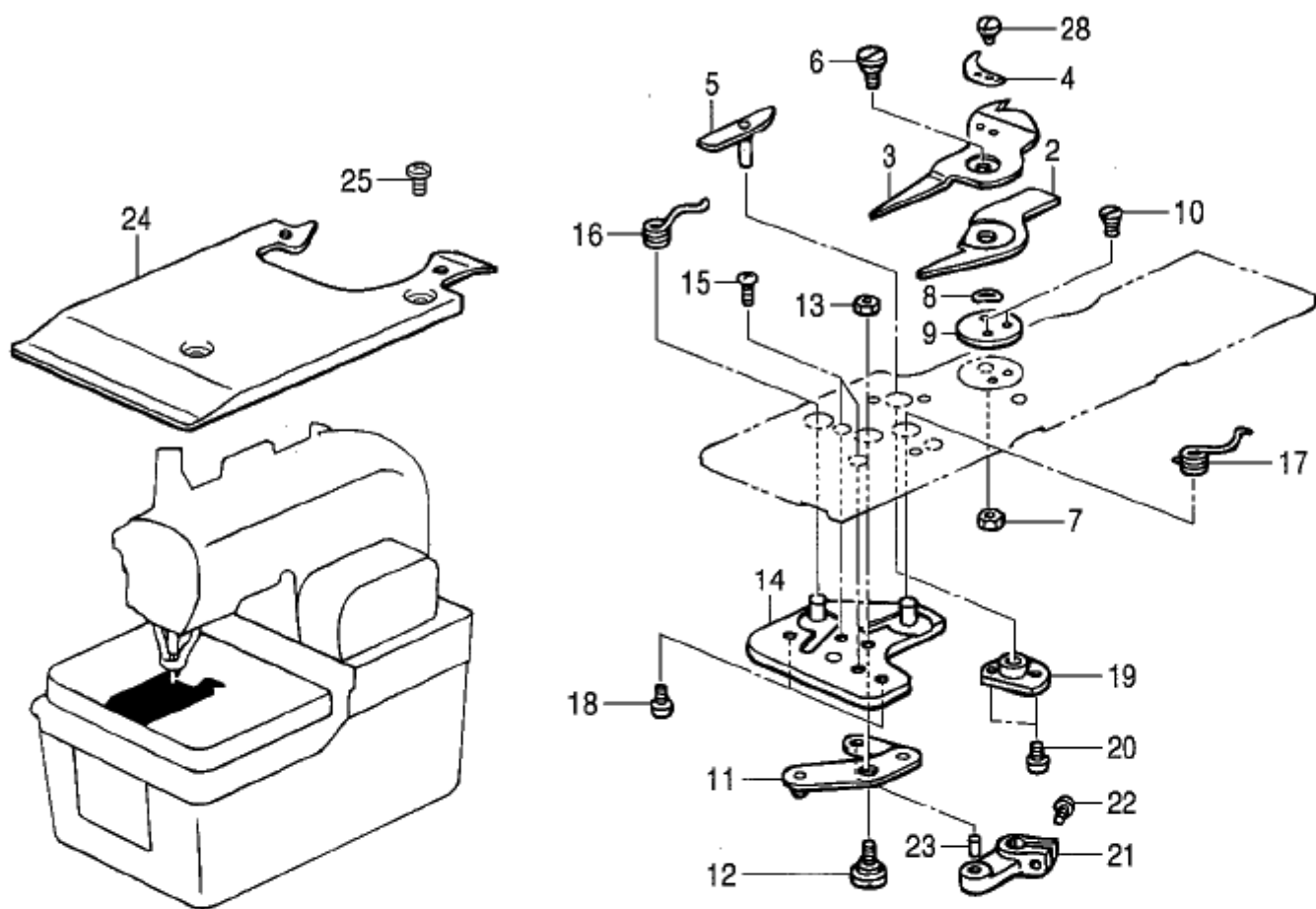

" オプション部品 / OPTION PARTS "

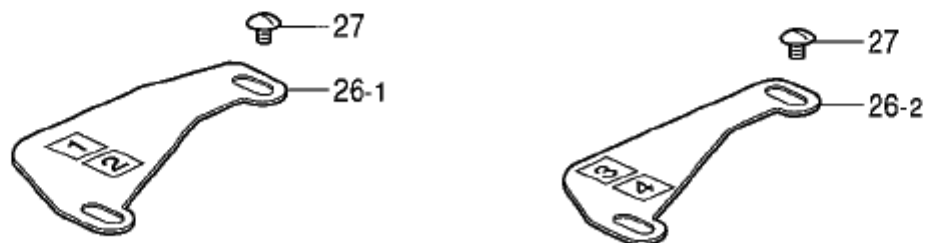

R2 . 糸切り関係 / Thread trimmer mechanism

REF.NO	CODE	QTY	ヒンメイ	NAME OF PARTS	RM
2	S37673101	1	<L1 14-18mm> 1 付*ウ*ル1R	<L1 14-18mm> MOVABLE KNIFE, R L1	
3	S37669101	1	1 付*ウ*ル1L	MOVABLE KNIFE, L L1	
4	S37665000	1	1 付サ*ハ*キL1	THREAD HANDLER, L1	
5	S37661101	1	1 付*ウ*ハ*ウ*ト*ウ*カ*ムL1	MOVABLE KNIFE DRIVING CAM, L1	
2	S37674101	1	<L2 18-22mm> 1 付*ウ*ル2R	<L2 18-22mm> MOVABLE KNIFE, R L2	
3	S37670101	1	1 付*ウ*ル2L	MOVABLE KNIFE, L L2	
4	S37666000	1	1 付サ*ハ*キL2	THREAD HANDLER, L2	
5	S37662101	1	1 付*ウ*ハ*ウ*ト*ウ*カ*ムL2	MOVABLE KNIFE DRIVING CAM, L2	
2	S37675101	1	<L3 22-26mm> 1 付*ウ*ル3R	<L3 22-26mm> MOVABLE KNIFE, R L3	
3	S37671101	1	1 付*ウ*ル3L	MOVABLE KNIFE, L L3	
4	S37667000	1	1 付サ*ハ*キL3	THREAD HANDLER, L3	
5	S37663101	1	1 付*ウ*ハ*ウ*ト*ウ*カ*ムL3	MOVABLE KNIFE DRIVING CAM, L3	
2	S37676101	1	<L4 26-30mm> 1 付*ウ*ル4R	<L4 26-30mm> MOVABLE KNIFE, R L4	
3	S37672101	1	1 付*ウ*ル4L	MOVABLE KNIFE, L L4	
4	S37668000	1	1 付サ*ハ*キL4	THREAD HANDLER, L4	
5	S37664101	1	1 付*ウ*ハ*ウ*ト*ウ*カ*ムL4	MOVABLE KNIFE DRIVING CAM, L4	
6	S37660101	1	1 タ*ン*ネ*ジ*M4	SHOULDER SCREW, M4	
7	021400202	1	1 ニ*ユ*ナ*ツ*ト*4	NUT, 2 M4	
8	S37654000	1	1 ナ*ミ*サ*カ*ネ	WASHER, WAVE	
9	S37655101	1	1 メ*ス*サ*エ*サ*カ*ネ	WASHER, ;KNIFE SUPPORT	
10	141542001	2	2 サ*ラ*ネ*ジ*3.18	SCREW 3.18	
11	S37656001	1	1 付*キ*リ*リ*ン*ク*レ*バ*ー*J*ク*ミ	T-TRIMMER LINK LEVER ASSY, J	
12	S34881001	1	1 タ*ン*ネ*ジ*M4	SHOULDER SCREW, M4	
13	021400202	1	1 ニ*ユ*ナ*ツ*ト*4	NUT, 2 M4	
14	S37820001	1	1 リ*ン*ク*シ*テ*ン*プ*レ*ー*ト*ク*ミ	LINK FULCRUM PLATE ASSY	
15	062400616	2	2 ナ*ハ*コ*M4X6	SCREW, PAN M4X6	
16	S37652001	1	1 付*ト*シ*ハ*ネ	SPRING, L TWIST	
17	S37653001	1	1 付*ト*シ*ハ*ネ	SPRING, R TWIST	
18	062300416	2	2 ナ*ハ*コ*M3X4	SCREW, PAN M3X4	
19	S34906100	1	1 付*キ*リ*リ*ン*ク*レ*バ*ー*メ*タル	BUSH, ;TR TRIMMER ARM	
20	062260612	2	2 ナ*ハ*コ*2.6X6	SCREW, PAN M2.6X6	
21	S37659001	1	1 付*キ*リ*リ*ン*ク*レ*バ*ー*ウ*テ*B	THREAD TRIMMER LEVER ARM, B	
22	S21716001	1	1 ナ*ハ*コ*タ*ン*ハ*ツ*ト*ネ*ジ*4X1	SCREW, BUTTON HEAD M4X10	
23	S37858000	1	1 ニ*ー*ト*ピ*ン*4X8	NEEDLE PIN, 4X8	
24	S56025001	1	1 プ*レ*ッ*サ*P*ラ*テ*U	PRESSER PLATE, U	
25	060400516	2	2 ナ*ハ*コ*バ*イ*ン*ト*M4X5	SCREW, BIND M4X5	
28	153787001	2	2 シ*メ*ネ*ジ*2.38	SCREW, SM2.38	
26-1	S37698000	1	"オ*プ*シ*ョ*ン*部*品" 1 付*ト*シ*ハ*カ*ハ*ー*L1-2	"OPTION PARTS" MOVABLE KNIFE COVER, L1-2	
26-2	S37699000	1	1 付*ト*シ*ハ*カ*ハ*ー*L3-4	MOVABLE KNIFE COVER, L3-4	
27	S35326001	2	2 シ*メ*ネ*ジ*M3.5	SCREW, M3.5	

S. 上糸切り関係 / Upper thread trimmer mechanism

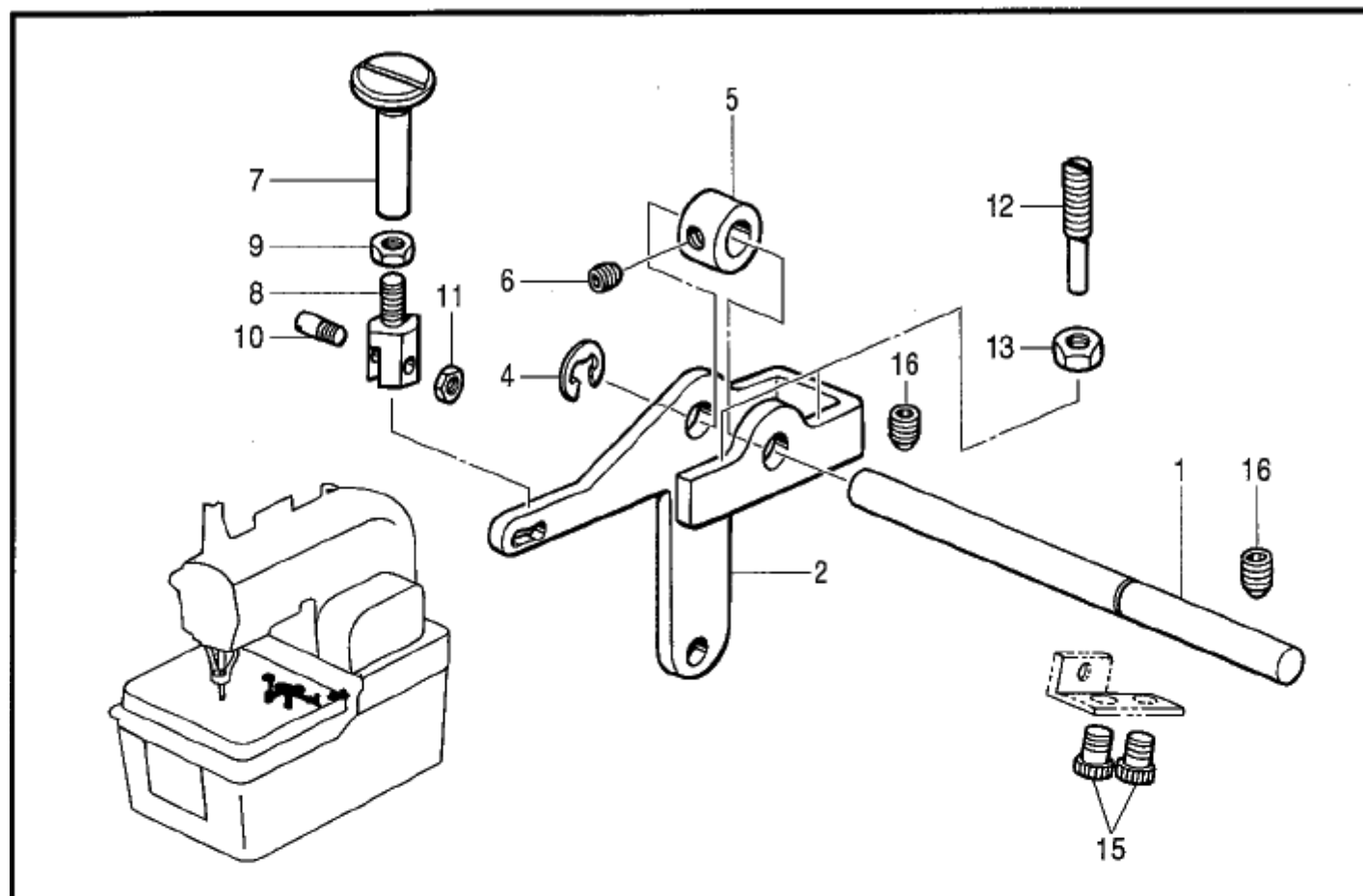

118-981-409

T. 針位置検出器関係 / Synchronizer

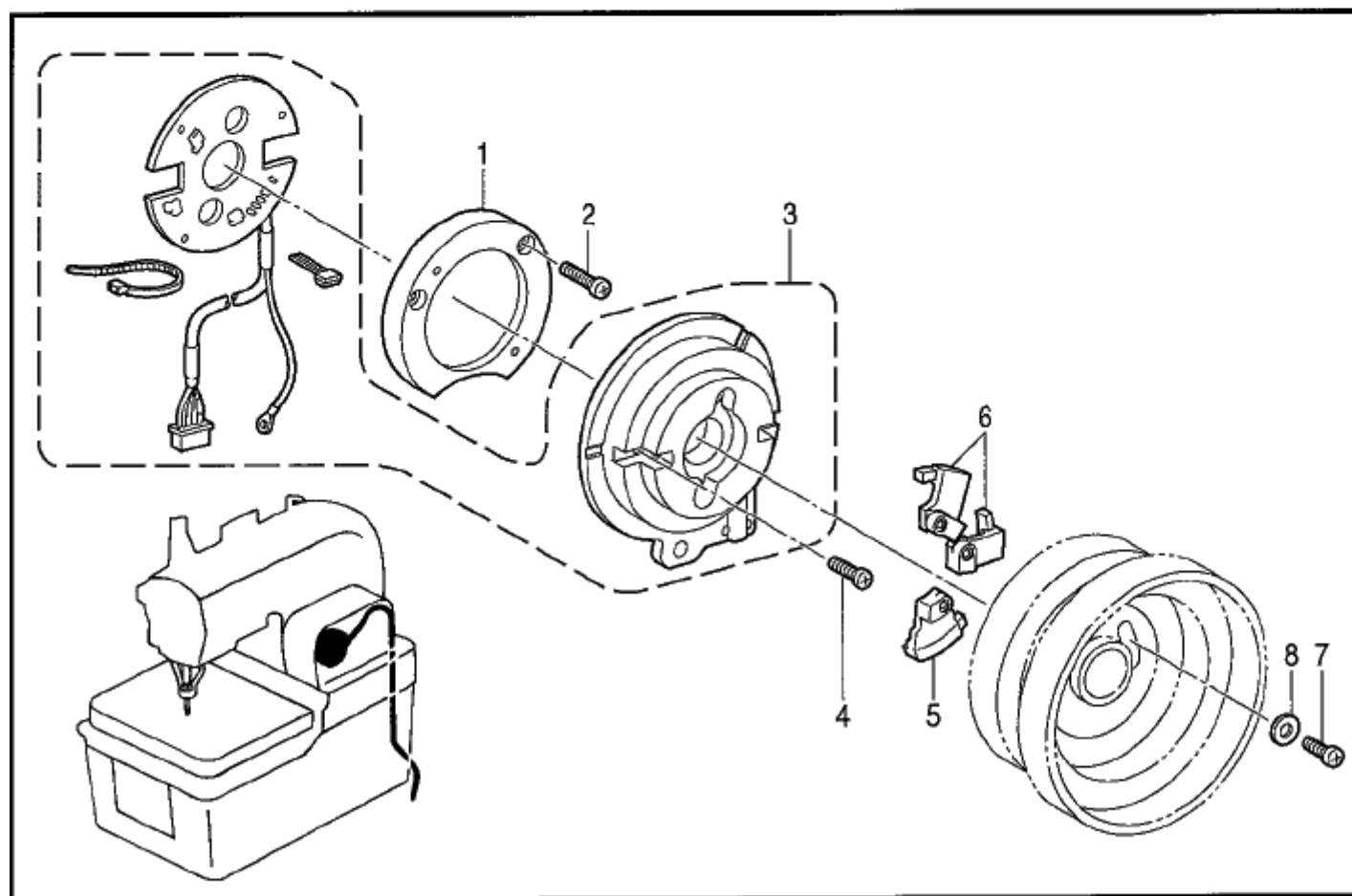

118-981-501

S . 上糸切り関係 / Upper thread trimmer mechanism

REF.NO	CODE	Q'TY	ヒンメイ	NAME OF PARTS	RM
1	S35058001	1	トキリレバ ^レ シ ^ク	LEVER SHAFT, ;TR	
2	S35059001	1	トキリレバ ^レ	LEVER, ;TR	
4	048050342	1	トメ ^レ E5	RETAINING RING, E5	
5	S35060001	1	セットカラ ^レ	SET SCREW COLLAR	
6	014400432	1	ソコボ ^レ ミ4X4	SET SCREW, SOCKET (CP) M4X4	
7	S35361001	1	トキリレバ ^レ ハンマ	HAMMER, ;TR-LEVER	
8	S35362001	1	トキリ子ヨウセツネジ	ADJUSTING SCREW	
9	021350106	1	1シユナツト35	NUT, 1 M3.5	
10	S35235001	1	クランプ ^レ ササヒ ^レ ン	SUPPORT PIN, ;CLAMP	
11	021300302	1	3シユナツト3	NUT, 3 M3	
12	S35364001	2	トメネジ ^レ 4X26	SET SCREW, M4X26	
13	021400202	2	2シユナツト4	NUT, 2 M4	
15	018401032	2	ソコボ ^レ ボルト4X10	BOLT, SOCKET M4X10	
16	014060632	2	ソコボ ^レ ミ6X6	SET SCREW, SOCKET (CP) M6X6	

118-981-409

T . 針位置検出器関係 / Synchronizer

REF.NO	CODE	Q'TY	ヒンメイ	NAME OF PARTS	RM
1	S43707001	1	NPササエダイB	NP SUPPORT BRACKET, B	
2	062401016	2	ソコボ ^レ コ4X10	SCREW, PAN M4X10	
3	S48674001	1	シンクロナイザ ^レ クミB	SYNCHRONIZER ASSY, B	
4	062400612	2	ソコボ ^レ コM4X6	SCREW, PAN M4X6	
5	S38080001	1	マグネツト ^レ シヤク ^レ ミ	MAGNET ASSY, D	
6	S43747001	2	マグネツト ^レ シヤク ^レ ミS	MAGNET ASSY, S ;N-UNDER	
7	062681412	3	ソコボ ^レ コ4.37-40X14	SCREW, PAN SM4.37-40X14	
8	025680132	3	ヒラサ ^レ ガ ^レ ネヨウ4.37	WASHER, PLAIN S 4.37	

118-981-501

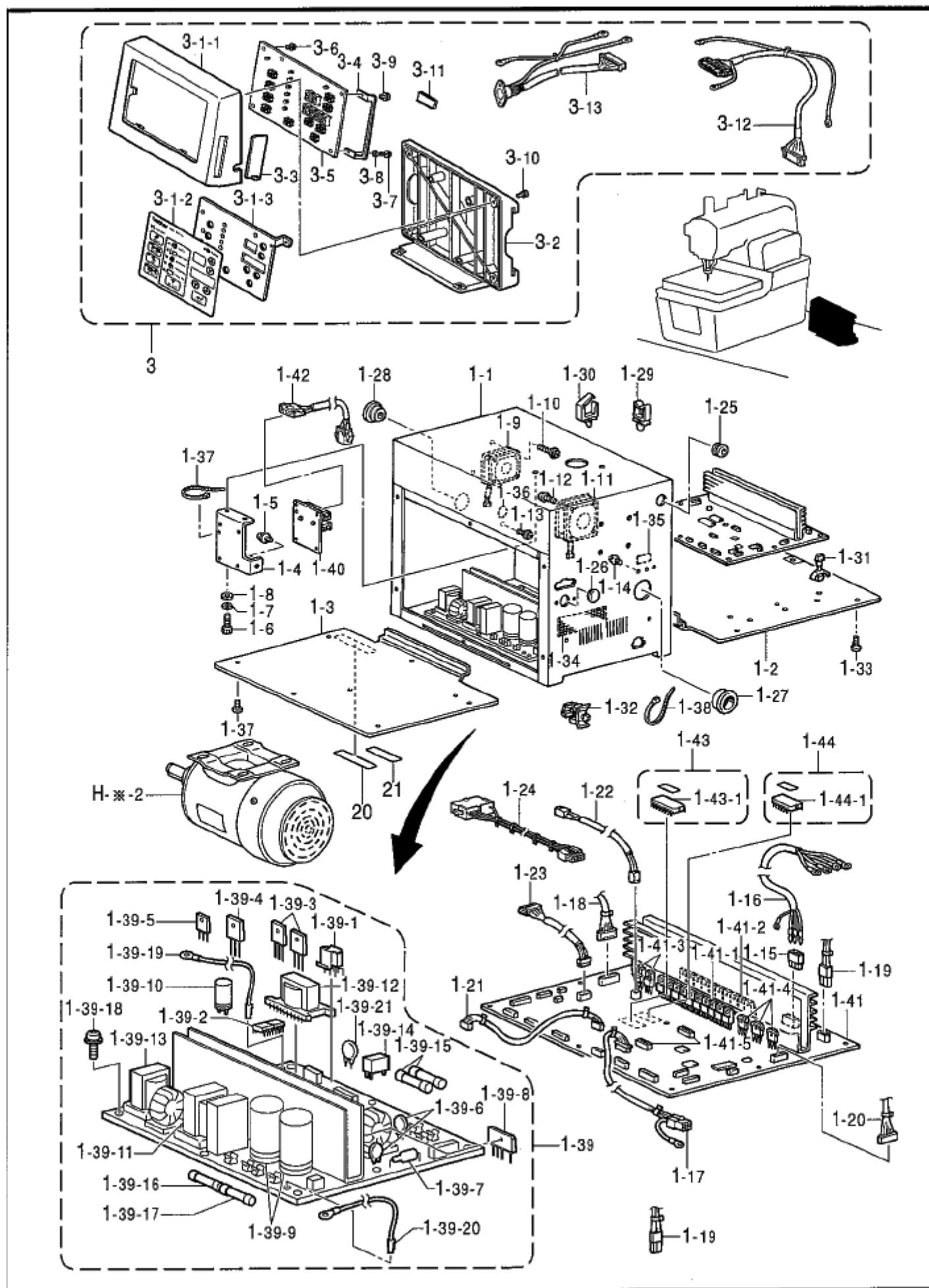

U1 . コントロールボックス関係 / Control box mechanism

REF.NO	CODE	QTY	ヒンメイ	NAME OF PARTS	RM
1	S59701001	1	981ボックス	BOX ASSY, 981	
1-1	S43300009	1	981電源ボックス	POWER SUPPLY BOX ASSY, 981	
1-2	S43171009	1	基板調整板	SETTING PLATE, PCB	
1-3	S59000001	1	981パネルキャップ	PANEL CAP ASSY, 981	
1-4	S43356001	1	R基板ベース	PCB BASE PLATE, R	
1-5	0A5400806	1	十字ネジM4X8DB	SCREW, PAN (S/P WASHER) M4X8	
1-6	018061022	2	六角ボルトM6X10	BOLT, SOCKET M6X10	
1-7	028060246	2	ワッシャー2-6	WASHER, SPRING 2-6	
1-8	025060232	2	ワッシャーM6	WASHER, PLAIN M 6	
1-9	S38094100	1	DCファンモーター	DC-FAN MOTOR ASSY	
1-10	0A5403006	2	十字ネジM4X30DB	SCREW, PAN (S/P WASHER) M4X30	
1-11	S43355000	1	DCファンモーター80	DC-FAN MOTOR ASSY, 80	
1-12	0A5403006	4	十字ネジM4X30DB	SCREW, PAN (S/P WASHER) M4X30	
1-13	0A5401006	1	十字ネジM4X10	SCREW, PAN (S/P WASHER) M4X10	
1-14	0A5401006	3	十字ネジM4X10	SCREW, PAN (S/P WASHER) M4X10	
1-15	S16568000	1	コネクタ3191-03R1	CONNECTOR, ;3191-03R1	
1-16	S43350000	1	モーターコード	MOTOR CORD	
1-17	S42260000	1	フットスイッチハーネス434	FOOT SWITCH HARNESS ASSY, 434	
1-18	S38107100	1	電源供給ハーネス	POWER SUPPLY HARNESS, CONTROL	
1-19	S38108000	1	電源供給ハーネスモーター	POWER SUPPLY HARNESS, MOTOR	
1-20	S38109100	1	電源供給ハーネスH-P	POWER SUPPLY HARNESS, H-P	
1-21	S38110000	1	電源ハーネス	POWER HARNESS	
1-22	S43304000	1	DC55コード	DC55 CORD	
1-23	S43306000	1	RPMコード	RPM CORD	
1-24	S58995000	1	タイプハーネス	TYPE HARNESS	
1-25	S11949000	1	ゴムブッシュ	RUBBER BUSH	
1-26	150592001	1	ゴムキャップ16	RUBBER CAP, 16	
1-27	S43274000	1	ブッシュTB-2938	BUSH, TB-2938	
1-28	S43308000	1	ブッシュTB-2533	BUSH, TB-2533	
1-29	S43275000	10	コードクランプWS2NS	CORD CLAMP, WS2NS	
1-30	S43318000	5	クランプLWS8S 2.5W	CLAMP, LWS8S 2.5W	
1-31	S00554000	22	支持台6NS	SUPPORT, 6NS	
1-32	S31760000	2	CKSクランプ26L	CORD CLAMP, 26-L	
1-33	008400604	12	トラスコX6	SCREW, TRUSS M4X6	
1-34	S43309000	1	破片保護ネット	FRAGMENT PROTECTOR NET	
1-35	S37059001	1	PEマーク	LABEL, PE	
1-36	S37060001	1	アースマーク	LABEL, GROUNDING	
1-37	228475000	3	固定バンド1.9X8	FASTENING BAND, 1.9X80	
1-38	228475000	1	固定バンド1.9X8	FASTENING BAND, 1.9X80	
1-39	S49939101	1	電源供給基板	POWER SUPPLY PCB ASSY	
1-39-1	S43177000	1	ICMA3830	IC :MA3830	
1-39-2	S43184000	2	フォトカプラーPC923	PHOTO COUPLER :PC923	
1-39-3	S49586000	2	MOSFET2SK1941	TRANSISTOR, FET :2SK1941	
1-39-4	S47668000	1	ダイオードPA905C6	DIODE, AR :PA905C6	
1-39-5	S38203000	1	ダイオードYG8022C04R	DIODE :YG8022C04R	
1-39-6	SA0037000	2	バリスタV14D511	VARISTOR :V14D511	
1-39-7	232384001	1	サージアブソーバDSA362M	SURGE ABSORBER :DSA362MA	
1-39-8	S49071000	1	ダイオードブリッジ25XB60	DIODE BRIDGE :25XB60	
1-39-9	S38205000	1	コンデンサ250B182	CAPACITOR, ALUM-ELEC :250B182	
1-39-10	SA1034000	1	コンデンサC63B562	CAPACITOR, ALUM-ELEC :63B562	
1-39-11	S43175000	1	変圧器54AA159	TRANSFORMER :54AA159	
1-39-12	S43176000	1	変圧器35AD199	TRANSFORMER :35AD199	
1-39-13	S43181000	1	コイル49AD289A	COIL :49AD289AC	
1-39-14	S38208000	1	リレーJW1AFSND5V	RELAY :JW1AFSN/DC 5V	
1-39-15	153242000	2	ヒューズ6A	FUSE, 6A	
1-39-16	S08030000	1	ヒューズ5AFB	FUSE, 5A :FB	
1-39-17	S48580000	1	ヒューズ7AFB	FUSE, 7A :FB	
1-39-18	0A4301005	8	十字ネジM3X10DA	SCREW, PAN (S/P WASHER) M3X10	
1-39-19	S43189000	1	PCBE1コード	HARNESS, PCB :E1	
1-39-20	S43187000	1	PCBE2コード	HARNESS, PCB :E2	
1-39-21	S49472000	1	サーミスタ6D-22	THERMISTOR :6D-22	

U1 . コントロールボックス関係 / Control box mechanism

REF.NO	CODE	Q'TY	ヒンメイ	NAME OF PARTS	RM
1-40	S59708001	1	PMDキハ`ンクミ	PMD PCB ASSY	
1-41	S53884001	1	メインキハ`ンクミ	MAIN PCB ASSY	
1-41-1	S49485000	10	MOSFETFX6KMJ-2	TRANSISTOR, FET :FX6KMJ-2	
1-41-2	S49484000	10	MOSFETFS10KMJ-2	TRANSISTOR, FET :FS10KMJ-2	
1-41-3	S38155000	4	MOSFET2SK1306	TRANSISTOR, FET :2SK1306	
1-41-4	S49471000	6	MOSFETFK18SM-12	TRANSISTOR, FET :FK18SM-12	
1-41-5	U32744000	2	DIPSWDSS708	DIP SWITCH:DSS708	
1-42	S45261000	1	Rキハ`ンチユウケイコト`	R-PCB RELAY CORD	
1-43	S59702000	1	PROMRH981Aメインクミ	PROM RH981A MAIN ASSY	
1-43-1	UA4897000	1	MOSLS127C2001	EPROM:27C2001	
1-44	S59703000	1	PROMRH981Aモ`タクミ	PROM ASSY, RH981A MOTOR	
1-44-1	U85274000	1	LSIM5M27C101K15	CMOS LSI, 27C512	
3	S59730001	1	ソウサハ`ネルクミ	OPERATION PANEL ASSY	
3-1	S58997001	1	ハ`ネルマエフレームクミ	FRONT FRAME ASSY	
3-1-1	S58975000	1	ソウサハ`ネルマエフレーム	FRONT FRAME	
3-1-2	S58998000	1	ハ`ネルシート	PANEL SHEET	
3-1-3	S52978000	1	ハ`ネルシートウライタ	PANEL SHEET BACK PLATE	
3-2	S52979000	1	ソウサハ`ネルウシロ	REAR FRAME	
3-3	S49495000	1	ハ`ネルヨコカバー`	PANEL SIDE COVER	
3-4	S49496001	1	ハ`ネルヨコカバー`ガイド`	PANEL SIDE COVER GUIDE	
3-5	S53010101	1	ハ`ネルキハ`ンクミ	PANEL PCB ASSY	
3-6	087310815	2	カヅフ`Bタイト3X8	TAPTITE, CUP B M3X8	
3-7	087311015	2	カヅフ`Bタイト3X10	TAPTITE, CUP B M3X10	
3-8	XA2220050	2	キハ`ンオサエ	BOARD PRESSER	
3-9	0A4400805	1	ナハ`サ`クミ4X8DA	SCREW, PAN (S/P WASHER) M4X8	
3-10	018300636	4	アナホ`ルト3X6	BOLT, SOCKET M3X6	
3-11	S59704000	1	PROM981Aハ`ネルクミ	PROM 981A PANEL ASSY	
3-12	S58976000	1	P/Mハ`ネスクミ	P/M HARNESS ASSY	
3-13	S59740000	1	PRG/Mハ`ネス981クミ	PRG/M HARNESS 981 ASSY	
20	S38352101	2	<輸出用> デン`ク`キラハ`ル. 4カコク	<For Export only> LABEL, ELEC. SHOCK 4 LANG.	
21	S38353101	2	<国内用> デン`ク`キラハ`ル. 7	<For Japan only> -----	
H-1	S59711001	1	<三相200V, 220V用> モ`タユニットコンホ`ウA1	<For " 3-phase 200V & 220V AC "> MOTOR UNIT, A1	※
H-1-1	S59721001	1	981ホ`クスソクミA1	BOX SET, 981 A1	※
H-1-2	S44758000	1	セ`ンハイ3ソウモ`タ	TOTALLY ENCLOSED 3-PHASE MOTOR	※
H-1-3	S59730001	1	ソウサハ`ネルクミ	OPERATION PANEL ASSY	※
H-2	S59712001	1	<单相220V用> モ`タユニットコンホ`ウA2	<For " 1-phase 220V AC "> MOTOR UNIT, A2	※
H-2-1	S59722001	1	981ホ`クスソクミA2	BOX SET, 981 A2	※
H-2-2	S44758000	1	セ`ンハイ3ソウモ`タ	TOTALLY ENCLOSED 3-PHASE MOTOR	※
H-2-3	S59730001	1	ソウサハ`ネルクミ	OPERATION PANEL ASSY	※
H-3	S59713001	1	<单相100V用> モ`タユニットコンホ`ウB1	<For Japan only> MOTOR UNIT, B1	※
H-3-1	S59723001	1	981ホ`クスソクミB1	BOX SET, 981 B1	※
H-3-2	S44758000	1	セ`ンハイ3ソウモ`タ	TOTALLY ENCLOSED 3-PHASE MOTOR	※
H-3-3	S59730001	1	ソウサハ`ネルクミ	OPERATION PANEL ASSY	※
H-4	S59714001	1	<单相110V用> モ`タユニットコンホ`ウB2	<For " 1-phase 110V AC "> MOTOR UNIT, B2	※
H-4-1	S59724001	1	981ホ`クスソクミB2	BOX SET, 981 B2	※
H-4-2	S44758000	1	セ`ンハイ3ソウモ`タ	TOTALLY ENCLOSED 3-PHASE MOTOR	※
H-4-3	S59730001	1	ソウサハ`ネルクミ	OPERATION PANEL ASSY	※

U1 . コントロールボックス関係 / Control box mechanism

REF.NO	CODE	Q'TY	品名	NAME OF PARTS	RM
H-5	S59715001	1	<三相415V> モータユニットコンホ ^o C1	<For " 3-phase 415V AC "> MOTOR UNIT, C1	※
H-5-1	S59725001	1	981ホ ^o ヲクソウク ^o C1	BOX SET, 981 C1	※
H-5-2	S44758000	1	セ ^o ンヘイ3ソウモ ^o タ	TOTALLY ENCLOSED 3-PHASE MOTOR	※
H-5-3	S59730001	1	ソウサハ ^o ネルク ^o ミ	OPERATION PANEL ASSY	※
H-6	S59716001	1	<三相380V用> モータユニットコンホ ^o C2	<For " 3-phase 380V AC "> MOTOR UNIT, C2	※
H-6-1	S59726001	1	981ホ ^o ヲクソウク ^o C2	BOX SET, 981 C2	※
H-6-2	S44758000	1	セ ^o ンヘイ3ソウモ ^o タ	TOTALLY ENCLOSED 3-PHASE MOTOR	※
H-6-3	S59730001	1	ソウサハ ^o ネルク ^o ミ	OPERATION PANEL ASSY	※
H-7	S59717001	1	<単相240V用> モータユニットコンホ ^o C3	<For " 1-phase 240V AC "> MOTOR UNIT, C3	※
H-7-1	S59727001	1	981ホ ^o ヲクソウク ^o C3	BOX SET, 981 C3	※
H-7-2	S44758000	1	セ ^o ンヘイ3ソウモ ^o タ	TOTALLY ENCLOSED 3-PHASE MOTOR	※
H-7-3	S59730001	1	ソウサハ ^o ネルク ^o ミ	OPERATION PANEL ASSY	※
H-8	S59718001	1	<三相400V> モータユニットコンホ ^o E	<For " 3-phase 400V AC "> MOTOR UNIT, E	※
H-8-1	S59728001	1	981ホ ^o ヲクソウク ^o E	BOX SET, 981 E	※
H-8-2	S44758000	1	セ ^o ンヘイ3ソウモ ^o タ	TOTALLY ENCLOSED 3-PHASE MOTOR	※
H-8-3	S40623000	2	EMIコアTR-40-27	EMI CORE, TR-40-27	※
H-8-4	0A5401605	2	サ ^o ハ ^o サ ^o ク ^o M4X16DB	SCREW, PAN (S/P WASHER) M4X16	※
H-8-5	025040236	2	ヒラサ ^o カ ^o ネ ^o ユウ ^o 4	WASHER, PLAIN M 4	※
H-8-6	021400106	2	ナツト1 ^o ヲ ^o 4	NUT, 1 M4	※
H-8-7	S59730001	1	ソウサハ ^o ネルク ^o ミ	OPERATION PANEL ASSY	※
H-9	S59719001	1	<単相230V用> モータユニットコンホ ^o F	<For " 1-phase 230V AC "> MOTOR UNIT, F	※
H-9-1	S59729001	1	981ホ ^o ヲクソウク ^o F	BOX SET, 981 F	※
H-9-2	S44758000	1	セ ^o ンヘイ3ソウモ ^o タ	TOTALLY ENCLOSED 3-PHASE MOTOR	※
H-9-3	S40623000	2	EMIコアTR-40-27	EMI CORE, TR-40-27	※
H-9-4	0A5401605	2	サ ^o ハ ^o サ ^o ク ^o M4X16DB	SCREW, PAN (S/P WASHER) M4X16	※
H-9-5	025040236	2	ヒラサ ^o カ ^o ネ ^o ユウ ^o 4	WASHER, PLAIN M 4	※
H-9-6	021400106	2	ナツト1 ^o ヲ ^o 4	NUT, 1 M4	※
H-9-7	S59730001	1	ソウサハ ^o ネルク ^o ミ	OPERATION PANEL ASSY	※

118-981-502

RM欄に※が付いている部品をご注文頂きますと、基板等必要な部品が一式入ったセットになっております。
When ordering parts which have an asterisk(※) in the RM column, these parts will be supplied as a set together with other necessary parts such as circuit boards.

< 三相200V,220V用 / For "3-Phase 200V & 220V AC" >

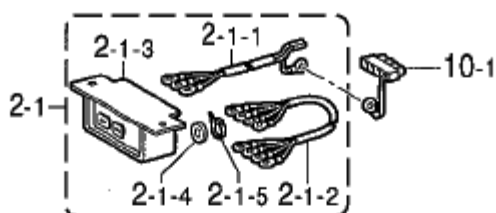

< 単相220V用 / For "1-Phase 220V AC" >

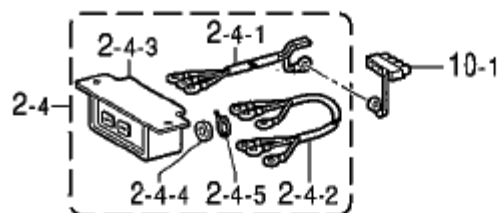

< 単相100V用 / For Japan only >

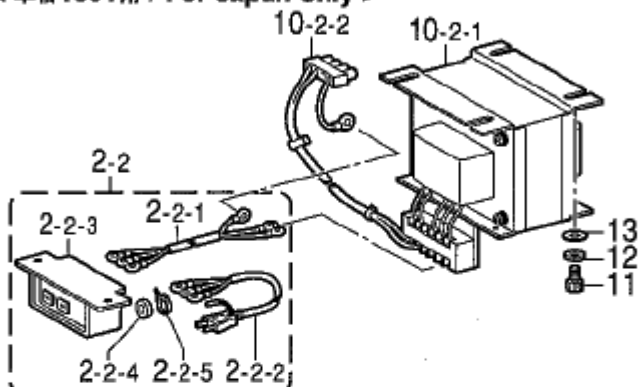

< 単相110V用 / For "1-Phase 110V AC" >

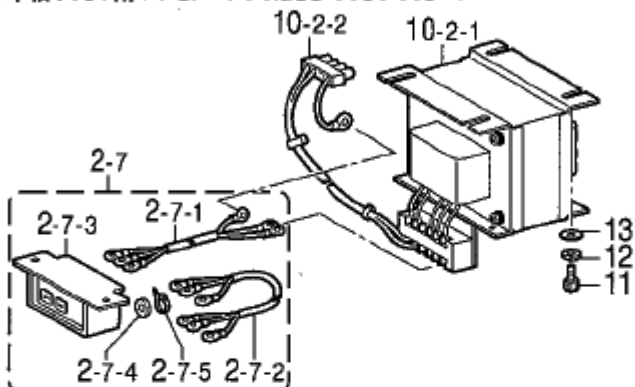

< 三相415V,380V用 / For "3-Phase 415V & 380V AC" >

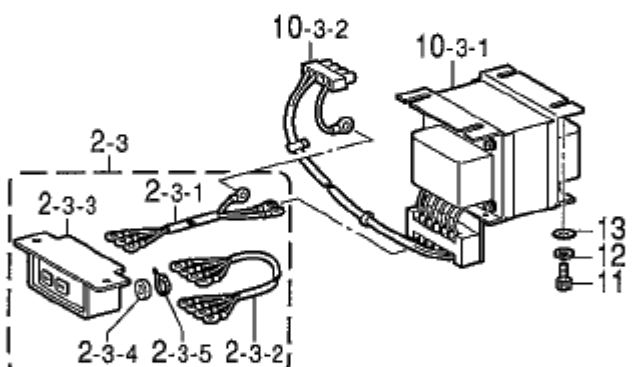

< 単相240V用 / For "1-Phase 240V AC" >

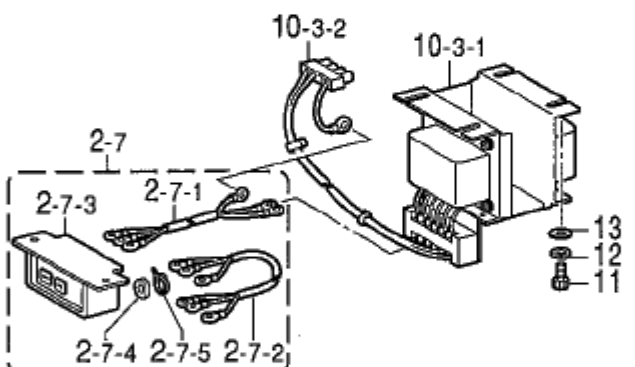

" オプション部品 / OPTION PARTS "

< 三相400V用 / For "3-Phase 400V AC" >

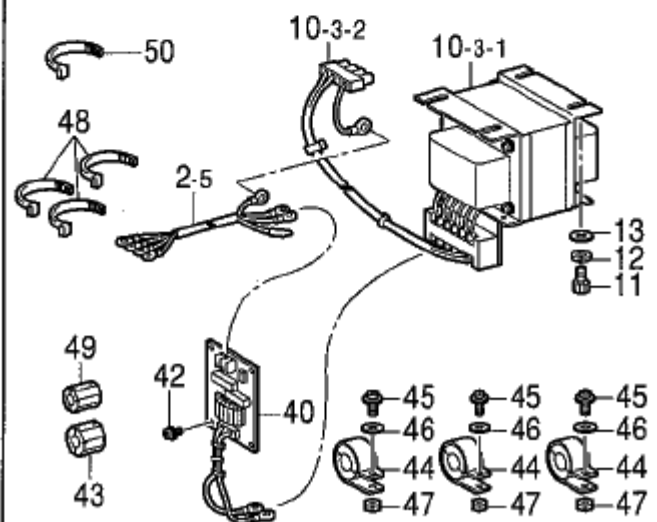

< 単相230V用 / For "1-Phase 230V AC" >

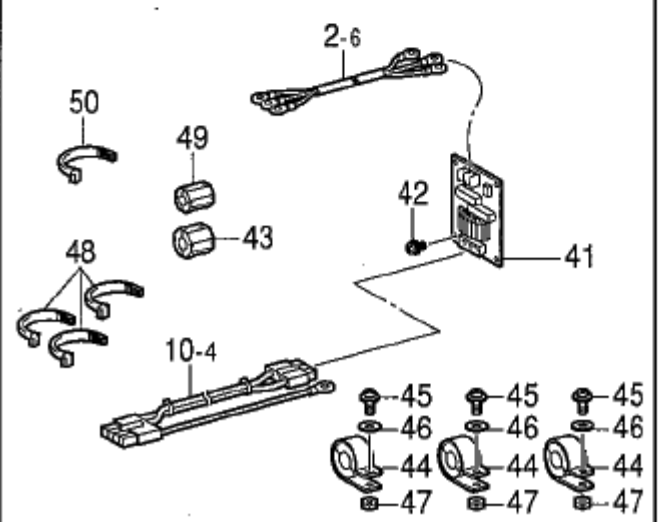

U2 . コントロールボックス関係 / Control box mechanism

REF.NO	CODE	QTY	ヒンメイ	NAME OF PARTS	RM
2-1	S38112001	1	<三相200V, 220V用> デンゲンSWクミA	<For " 3-phase 200V & 220V AC "> P-SUPPLY SWITCH ASSY, A	
2-1-1	S38113000	1	デンゲンINコートA	POWER SUPPLY HARNESS, A :IN	
2-1-2	S38133000	1	デンゲンコート	POWER SUPPLY HARNESS	
2-1-3	J02657001	1	3PオシSW#17	PUSH SWITCH, 3P #17	
2-1-4	224514001	2	セツエンタ	INSULATION PLATE	
2-1-5	218859001	2	ハインタM150	BINDER, M150	
2-2	S38114000	1	<单相100V用> デンゲンSWクミB	<For Japan only> -----	
2-2-1	S38115000	1	デンゲンINコートB	-----	
2-2-2	S38118000	1	デンゲンコートコナイ	-----	
2-2-3	J02657001	1	3PオシSW#17	-----	
2-2-4	224514001	2	セツエンタ	-----	
2-2-5	218859001	2	ハインタM150	-----	
2-3	S38117000	1	<三相415V, 380V用> デンゲンSWクミC	<For " 3-phase 415V & 380V AC "> POWER SUPPLY SWITCH ASSY, C	
2-3-1	S38115000	1	デンゲンINコートB	POWER SUPPLY HARNESS, B :IN	
2-3-2	S38133000	1	デンゲンコート	POWER SUPPLY HARNESS	
2-3-3	J02657001	1	3PオシSW#17	PUSH SWITCH, 3P #17	
2-3-4	224514001	2	セツエンタ	INSULATION PLATE	
2-3-5	218859001	2	ハインタM150	BINDER, M150	
2-4	S47592000	1	<单相220V用> デンゲンSWクミD	<For " 1-phase 220V AC "> P-SUPPLY SWITCH ASSY, D	
2-4-1	S38113000	1	デンゲンINコートA	POWER SUPPLY HARNESS, A :IN	
2-4-2	S47595000	1	デンゲンコートユシツ	POWER SUPPLY HARNESS, EXP.	
2-4-3	J02657001	1	3PオシSW#17	PUSH SWITCH, 3P #17	
2-4-4	224514001	2	セツエンタ	INSULATION PLATE	
2-4-5	218859001	2	ハインタM150	BINDER, M150	
2-7	S47594000	1	<单相110V, 240V用> デンゲンSWクミG	<For " 1-phase 110V & 240V AC "> P-SUPPLY SWITCH ASSY, G	
2-7-1	S38115000	1	デンゲンINコートB	POWER SUPPLY HARNESS, B :IN	
2-7-2	S47595000	1	デンゲンコートユシツ	POWER SUPPLY HARNESS, EXP.	
2-7-3	J02657001	1	3PオシSW#17	PUSH SWITCH, 3P #17	
2-7-4	224514001	2	セツエンタ	INSULATION PLATE	
2-7-5	218859001	2	ハインタM150	BINDER, M150	
10-1	S38123000	1	<单相220V, 三相200V, 220V用> ACINコネクタクミ	<For " 1-phase 220V AC 3-phase 200V & 220V AC "> AC CONNECTOR ASSY, IN	
10-2	S43369000	1	<单相100V, 110V用> ハカトランスクミ	<For " 1-phase 100V & 110V AC "> CONVERSION TRANSFORMER ASSY, B	
10-2-1	S43367000	1	ハカトランスB	CONVERSION TRANSFORMER, B	
10-2-2	S38126000	1	ACINコート	AC HARNESS, IN	
10-3	S43370000	1	<单相240V, 三相400V, 415V, 380V用> ハカトランスクミ	<For " 1-phase 240V AC 3-phase 400V, 415V & 380V AC "> CONVERSION TRANSFORMER ASSY, C	
10-3-1	S43368000	1	ハカトランスC	CONVERSION TRANSFORMER, C	
10-3-2	S38126000	1	ACINコート	AC HARNESS, IN	

< 三相200V,220V用 / For "3-Phase 200V & 220V AC" >

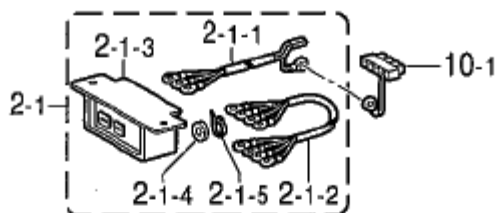

< 単相220V用 / For "1-Phase 220V AC" >

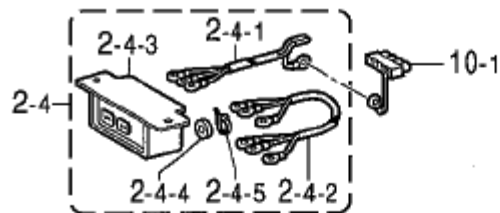

< 単相100V用 / For Japan only >

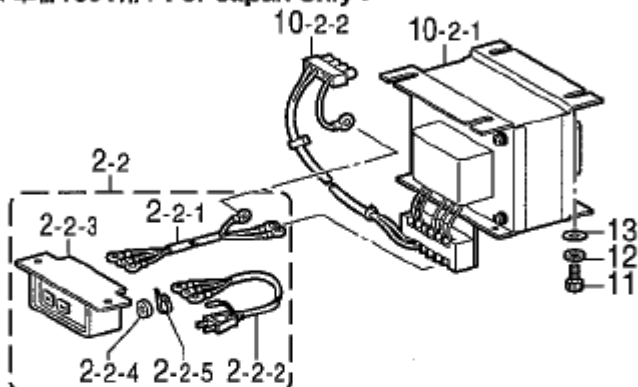

< 単相110V用 / For "1-Phase 110V AC" >

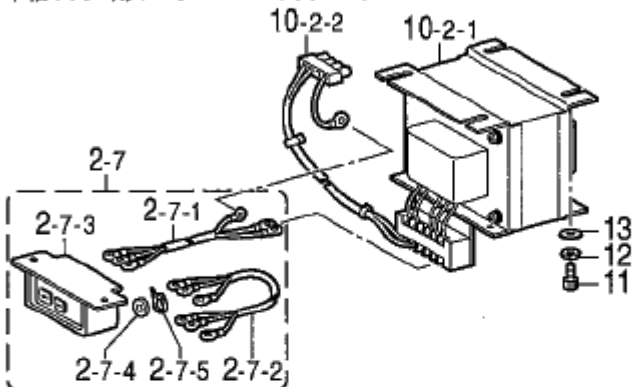

< 三相415V,380V用 / For "3-Phase 415V & 380V AC" >

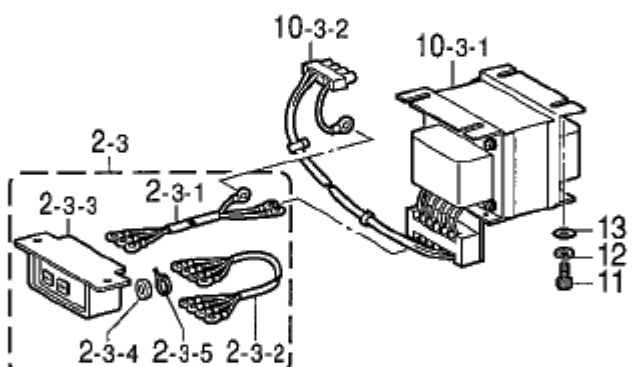

< 単相240V用 / For "1-Phase 240V AC" >

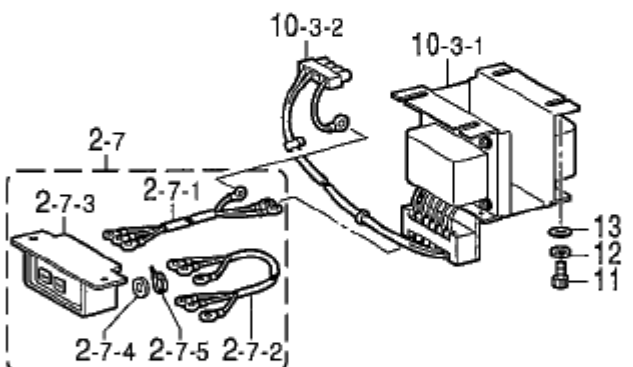

" オプション部品 / OPTION PARTS "

< 三相400V用 / For "3-Phase 400V AC" >

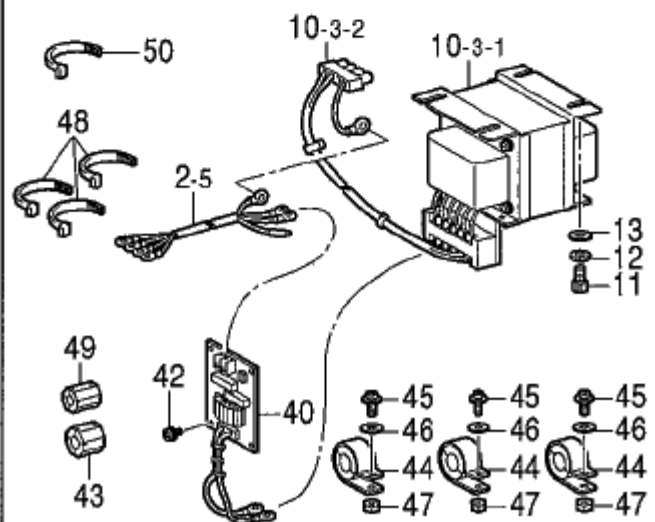

< 単相230V用 / For "1-Phase 230V AC" >

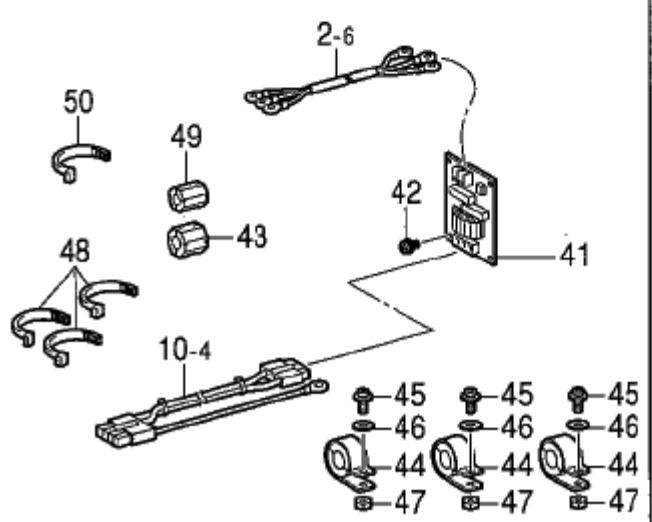

U2 . コントロールボックス関係 / Control box mechanism

REF.NO	CODE	Q'TY	ヒンメイ	NAME OF PARTS	RM
11	018061022	4	<200V, 220V以外用> ボルトM6X10	<Except for " 200V & 220V AC "> BOLT, SOCKET M6X10	
12	028060246	4	ワッシャースプリング2-6	WASHER, SPRING 2-6	
13	025060232	4	ワッシャープラインM6	WASHER, PLAIN M 6	
35	S52245000	1	GFUSE8A250FB	FUSE, 8A ;250FB	
			"オプション部品 "	"OPTION PARTS "	
			<三相400V用>	<For " 3-phase 400V AC ">	
2-5	S45035000	1	デンゲンインコトEH	POWER SUPPLY IN HARNESS, EH	
40	S40635001	1	ノイズフィルタ430E	NOISE FILTER ASSY, 430E	
40-1-1	S40616001	1	ノイズフィルタEMC	NOISE FILTER ASSY, EMC	
40-2-1	S40624000	1	ノイズフィルタハーネス	NOISE FILTER HARNESS, A	
			<単相230V用>	<For " 1-phase 230V AC ">	
2-6	S45036000	1	デンゲンインコトFH	POWER SUPPLY IN HARNESS, FH	
10-4	S43201000	1	ACインコトF	AC HARNESS, F :IN	
41	S40616001	1	ノイズフィルタEMC	NOISE FILTER ASSY, EMC	
			<単相230V用, 三相400V用>	<For " 1-phase 230V AC & 3-phase 400V AC">	
42	0A4400605	4	ナットM4X6DA	SCREW, PAN (S/P WASHER) M4X6	
43	S55473000	1	SIDPA905C6-F	DIODE, AR :PA905C6-F	

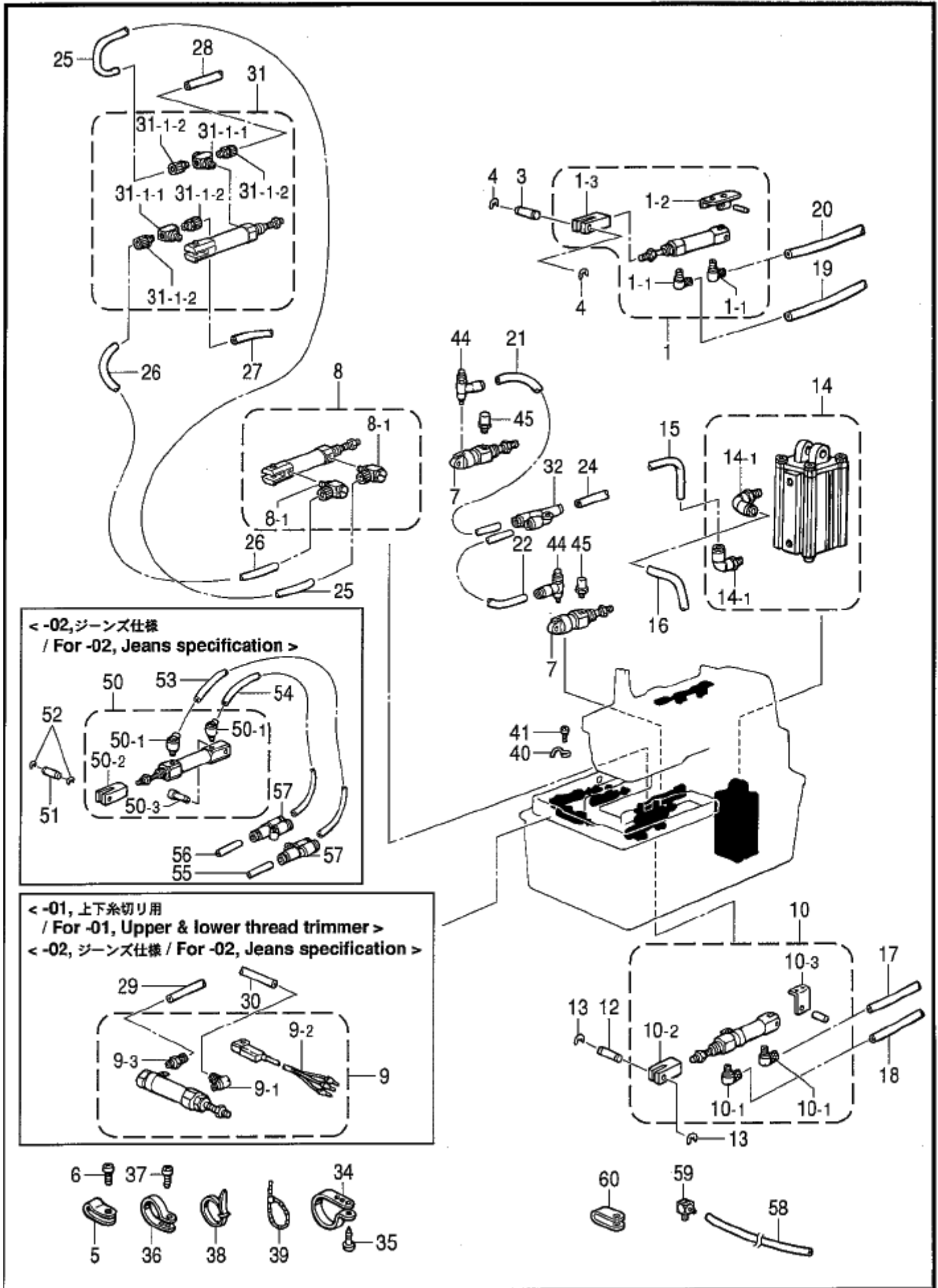

V1 . 空圧関係 / Air pressure mechanism

REF.NO	CODE	Q'TY	品名	NAME OF PARTS	RM
1	S35349101	1	シリンダ 10X15クミ	CYLINDER ASSY, 10X15	
1-1	S12150000	2	ホースエルボ M-5HL-4	TUBE ELBOW, M-5HL-4	
1-2	S34925101	1	シリンダサヤ	CYLINDER SUPPORT, ;T-RELEASE	
1-3	S35351001	1	シリンダロッド	CYLINDER ROD	
3	S35305001	1	シリンダロッドピン	ROD PIN, ;CYLINDER	
4	048030342	2	トマE3	RETAINING RING, E3	
5	149287000	1	ナイロンクランプ	CORD HOLDER, 7N	
6	062400812	1	ナハ M4X8	SCREW, PAN M4X8	
7	S35350000	2	シリンダ 16X10	CYLINDER, 16X10	
8	S44530000	1	シリンダ 16X15クミA	CYLINDER ASSY, A 16X15	
8-1	S12150000	2	ホースエルボ M-5HL-4	TUBE ELBOW, M-5HL-4	
10	S43731001	1	シリンダ 10X15クミ	CYLINDER ASSY, 10X15	
10-1	S12150000	2	ホースエルボ M-5HL-4	TUBE ELBOW, M-5HL-4	
10-2	S35351001	1	シリンダロッド	CYLINDER ROD	
10-3	S34916001	1	シリンダサヤ	CYLINDER SUPPORT	
12	S35305001	1	シリンダロッドピン	ROD PIN, ;CYLINDER	
13	048030342	2	トマE3	RETAINING RING, E3	
14	S35360000	1	シリンダ 63X100クミ	CYLINDER ASSY, 63X100	
14-1	S35426000	2	エルボ 10-4	ELBOW, 10-4	
15	S35417000	1	エアホース 10X6.5-11 L=1100	AIR TUBE, 10X6.5-11 L=1100	
16	S35909000	1	エアホース 10X6.5-18 L=1100	AIR TUBE, 10X6.5-18 L=1100	
17	S35367000	1	エアホース 4X2.5-9 L=1130	AIR TUBE, 4X2.5-9 L=1130	
18	S35368000	1	エアホース 4X2.5-10 L=1090	AIR TUBE, 4X2.5-10 L=1090	
19	S35369000	1	エアホース 4X2.5-7 L=1150	AIR TUBE, 4X2.5-7 L=1150	
20	S35370000	1	エアホース 4X2.5-8 L=1100	AIR TUBE, 4X2.5-8 L=1100	
21	S35371000	1	エアホース 4X2.5-14 L=1370	AIR TUBE, 4X2.5-14 L=1370	
22	S35372000	1	エアホース 4X2.5-17 L=1595	AIR TUBE, 4X2.5-17 L=1595	
24	S35374000	1	エアホース 4X2.5-1 L=100	AIR TUBE, 4X2.5-1 L=100	
25	S35375000	1	エアホース 4X2.5-12 L=360	AIR TUBE, 4X2.5-12 L=360	
26	S35376000	1	エアホース 4X2.5-13 L=320	AIR TUBE, 4X2.5-13 L=320	
27	S35377100	1	エアホース 4X2.5-3 L=1445	AIR TUBE, 4X2.5-3 L=1445	
28	S35378100	1	エアホース 4X2.5-4 L=1395	AIR TUBE, 4X2.5-4 L=1395	
31	S44531000	1	シリンダ 16X15クミB	CYLINDER ASSY, B 16X15	
31-1	S44532000	2	ホースニップル M	TUBE NIPPLE ASSY	
31-1-1	S01524000	1	ユニバーサルジョイント	T-JOINT, ;UNIVERSAL	
31-1-2	S11433000	2	ホースニップル M4M5	HOSE NIPPLE, 4M5	
32	S12104000	1	ユニオン Y4	UNION, Y 4	
34	158581000	3	コードホルダー #24	CORD HOLDER, 24N	
35	032422003	2	丸木ネジ 4.1X20	WOOD SCREW, ROUND M4.1X20	
36	S11817000	1	クランプ NK-18N	CLAMP, NK-18N	
37	062400816	1	ナハ M4X8	SCREW, PAN M4X8	
38	S04557000	7	バンド PLT1M	BAND, PLT1M	
39	340400001	4	ビードバンド	BEAD BAND	
40	152969001	1	コードサヤ	CORD SUPPORT	
41	062350616	1	ナハ M3.5X6	SCREW, PAN M3.5X6	
44	S35460000	2	スピードコン	SPEED CONTROLLER	
45	S13955000	2	エアボラ	AIR BOLSTER	
58	S40677000	1	エアホース 4X2.5-22 L=1750	AIR TUBE, 4X2.5-22 L=1750	
59	S40676000	1	バルブエルボ M5ALN4	VALVE ELBOW M5ALN4	
60	625010000	2	ナイロンクランプ NK-2N	CORD HOLDER, NK-2N	
			<-01, 上下糸切り用>	<For-01, Upper & lower thread trimmer>	
			<-02, ジーンズ仕様>	<For-02, jeans specification>	
9	S43772000	1	シリンダ 16X30クミB	CYLINDER ASSY, B 16X30	
9-1	S12150000	1	ホースエルボ M-5HL-4	TUBE ELBOW, M-5HL-4	
9-2	S43357000	1	シタOFFセンサーコード	LOWER OFF SENSOR CORD	
9-3	S11433000	1	ホースニップル M4M5	HOSE NIPPLE, 4M5	
29	S35398100	1	エアホース 4X2.5-5 L=1480	AIR TUBE, 4X2.5-5 L=1480	
30	S35399100	1	エアホース 4X2.5-6 L=1530	AIR TUBE, 4X2.5-6 L=1530	

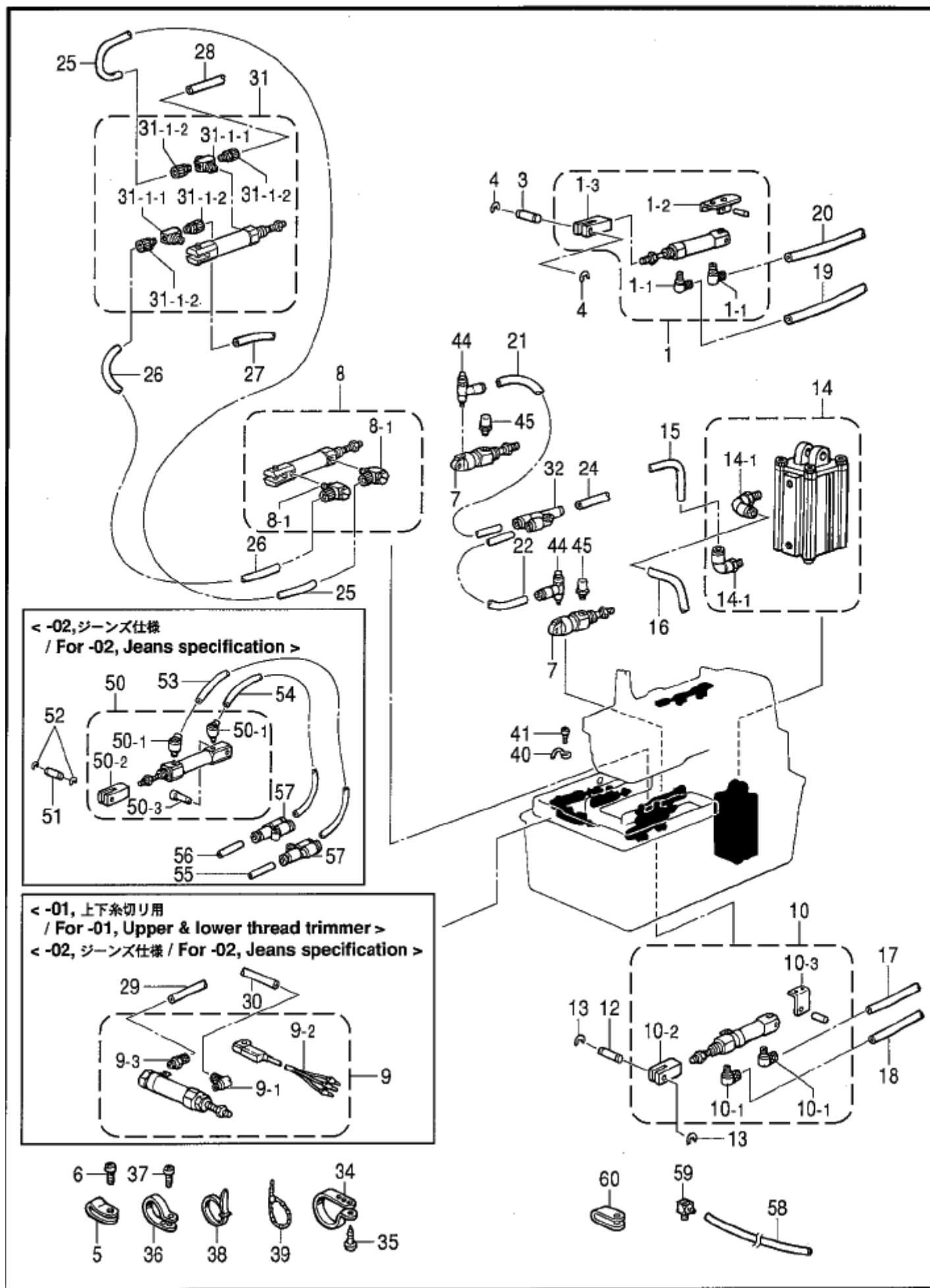

V1 . 空圧関係 / Air pressure mechanism

REF.NO	CODE	Q'TY	ヒンメイ	NAME OF PARTS	RM
50	S37737001	1	<-02, ジーンズ仕様> シリンダ' 10X15J'ミ	<For-02, jeans specification> CYLINDER ASSY, 10X15J	
50-1	S12150000	2	ホ-スI'ホ' M-5HL-4	TUBE ELBOW, M-5HL-4	
50-2	S35351001	1	シリンダ' ロット'	CYLINDER ROD	
50-3	S37866000	1	クレビ' スピ'ン	CLEVIS PIN	
51	S35305001	1	シリンダ' ロット' ピ'ン	ROD PIN, ;CYLINDER	
52	048030342	2	トメ' E3	RETAINING RING, E3	
53	S37738000	1	I'ア-ホ-ス4X2.5-20	AIR TUBE, 4X2.5-20 L=1350	
54	S37739000	1	I'ア-ホ-ス4X2.5-21	AIR TUBE, 4X2.5-21 L=1400	
55	S37863000	1	I'ア-ホ-ス4X2.5-3J	AIR TUBE, 4X2.5-3J L=100	
56	S37864000	1	I'ア-ホ-ス4X2.5-4J	AIR TUBE, 4X2.5-4J L=100	
57	S12104000	2	ユニオン' Y4	UNION, Y 4	

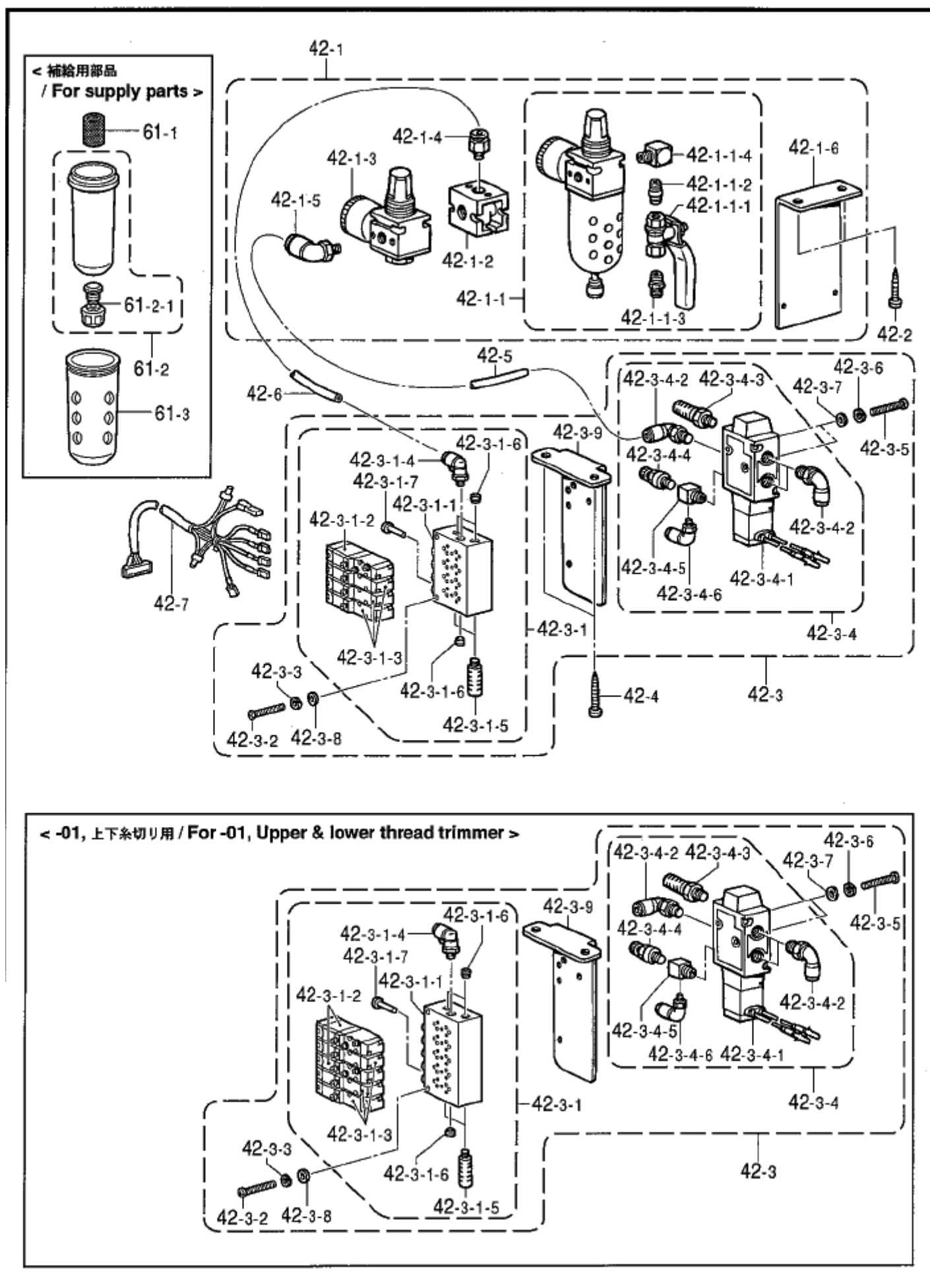

V1 . 空圧関係 / Air pressure mechanism

REF.NO	CODE	Q'TY	ヒンメイ	NAME OF PARTS	RM
42-1	S35389001	1	IA-ユニット	AIR UNIT ASSY	
42-1-1	S35386000	1	FRユニット	FR-UNIT ASSY	
42-1-1-1	S40628000	1	ボールバルブ 1/4	BALL VALVE, 1/4	
42-1-1-2	S40629000	1	バルブニツブ	BARREL NIPPLE	
42-1-1-3	S40630000	1	ニツブ	NIPPLE	
42-1-1-4	S48328000	1	PTエルボ	ELBOW, PT	
42-1-2	S35382000	1	ダイバタ	DIVERTER	
42-1-3	S35395000	1	レギュレーターR55	REGULATOR, R55	
42-1-4	S35423000	1	コネクタ10-3/8	CONNECTOR, 10-3/8	
42-1-5	S35424000	1	エルボ 10-1/4	ELBOW, 10-1/4	
42-1-6	S35425001	1	IA-ユニットリツケイタ	SETTING PLATE, ;A-UNIT	
42-2	031553202	2	丸ネジ 5.5X32	WOOD SCREW, ROUND M5.5X32	
42-4	031553202	2	丸ネジ 5.5X32	WOOD SCREW, ROUND M5.5X32	
42-5	S43769000	1	IA-ホース10X6.5-1	AIR TUBE, 10X6.5-15 L=370	
42-6	S43770000	1	IA-ホース10X6.5-1	AIR TUBE, 10X6.5-16 L=480	
42-7	S43344000	1	バルブコード	VALVE CORD ASSY	
			<-00, 上糸切り用>	<For-00,Upper thread trimmer>	
42-3	S44220001	1	バルブユニット4	VALVE UNIT ASSY, 4	
42-3-1	S44221000	1	ソレノイドバルブ4	SOLENOID VALVE ASSY, 4	
42-3-1-1	S44231000	1	マニホールド4	MANIFOLD, 4	
42-3-1-2	S43683001	1	ソレノイドバルブ	SOLENOID VALVE	
42-3-1-3	S44223000	3	ソレノイドバルブ	SOLENOID VALVE	
42-3-1-4	S44224000	1	メイルエルボ 10R-01M	ELBOW, 10R-01ML	
42-3-1-5	S23880000	2	IA-マフラー	AIR MUFFLER	
42-3-1-6	S44225000	3	プラグ R1/8	PLUG, R 1/8	
42-3-1-7	S44226000	1	プラグ RP-4	PLUG, R P-4	
42-3-2	062403512	2	ナット M4X35	SCREW, PAN M4X35	
42-3-3	028040246	2	ワッシャー カネコ 2-4	WASHER, SPRING 2-4	
42-3-4	S44215000	1	ソレノイドバルブ	AIR VALVE ASSY	
42-3-4-1	S44216000	1	ソレノイドバルブ RCS240	SOLENOID VALVE, RCS2408	
42-3-4-2	S44228000	3	ジョイント 3109-10	JOINT, 3109-10	
42-3-4-3	S44229000	1	IAマフラー SL-2	AIR MAFLER, SL-2	
42-3-4-4	S44217000	1	バルブ ET02	VALVE, ET02	
42-3-4-5	S44218000	1	ジョイント 1/4X1/4-M5	JOINT, 1/4X1/4-M5	
42-3-4-6	S44230000	1	ジョイント 3199-4	JOINT, 3199-4	
42-3-5	062403512	2	ナット M4X35	SCREW, PAN M4X35	
42-3-6	028040246	2	ワッシャー カネコ 2-4	WASHER, SPRING 2-4	
42-3-7	026040136	2	ワッシャー カネコ 4	WASHER, PLAIN S 4	
42-3-8	026040136	2	ワッシャー カネコ 4	WASHER, PLAIN S 4	
42-3-9	S44219001	1	バルブリツケイタ	SETTING PLATE, ;VALVE	
			<-01, 上下糸切り用>	<For-01,Upper & lower thread trimmer>	
42-3	S44213001	1	バルブユニット5	VALVE UNIT ASSY, 5	
42-3-1	S44214000	1	ソレノイドバルブ5	SOLENOID VALVE ASSY, 5	
42-3-1-1	S44222000	1	マニホールド5	MANIFOLD, 5	
42-3-1-2	S43683001	2	ソレノイドバルブ	SOLENOID VALVE	
42-3-1-3	S44223000	3	ソレノイドバルブ	SOLENOID VALVE	
42-3-1-4	S44224000	1	メイルエルボ 10R-01M	ELBOW, 10R-01ML	
42-3-1-5	S23880000	2	IA-マフラー	AIR MUFFLER	
42-3-1-6	S44225000	3	プラグ R1/8	PLUG, R 1/8	
42-3-1-7	S44226000	1	プラグ RP-4	PLUG, R P-4	
42-3-2	062403512	2	ナット M4X35	SCREW, PAN M4X35	
42-3-3	028040246	2	ワッシャー カネコ 2-4	WASHER, SPRING 2-4	
42-3-4	S44215000	1	ソレノイドバルブ	AIR VALVE ASSY	
42-3-4-1	S44216000	1	ソレノイドバルブ RCS240	SOLENOID VALVE, RCS2408	
42-3-4-2	S44228000	3	ジョイント 3109-10	JOINT, 3109-10	
42-3-4-3	S44229000	1	IAマフラー SL-2	AIR MAFLER, SL-2	
42-3-4-4	S44217000	1	バルブ ET02	VALVE, ET02	
42-3-4-5	S44218000	1	ジョイント 1/4X1/4-M5	JOINT, 1/4X1/4-M5	
42-3-4-6	S44230000	1	ジョイント 3199-4	JOINT, 3199-4	

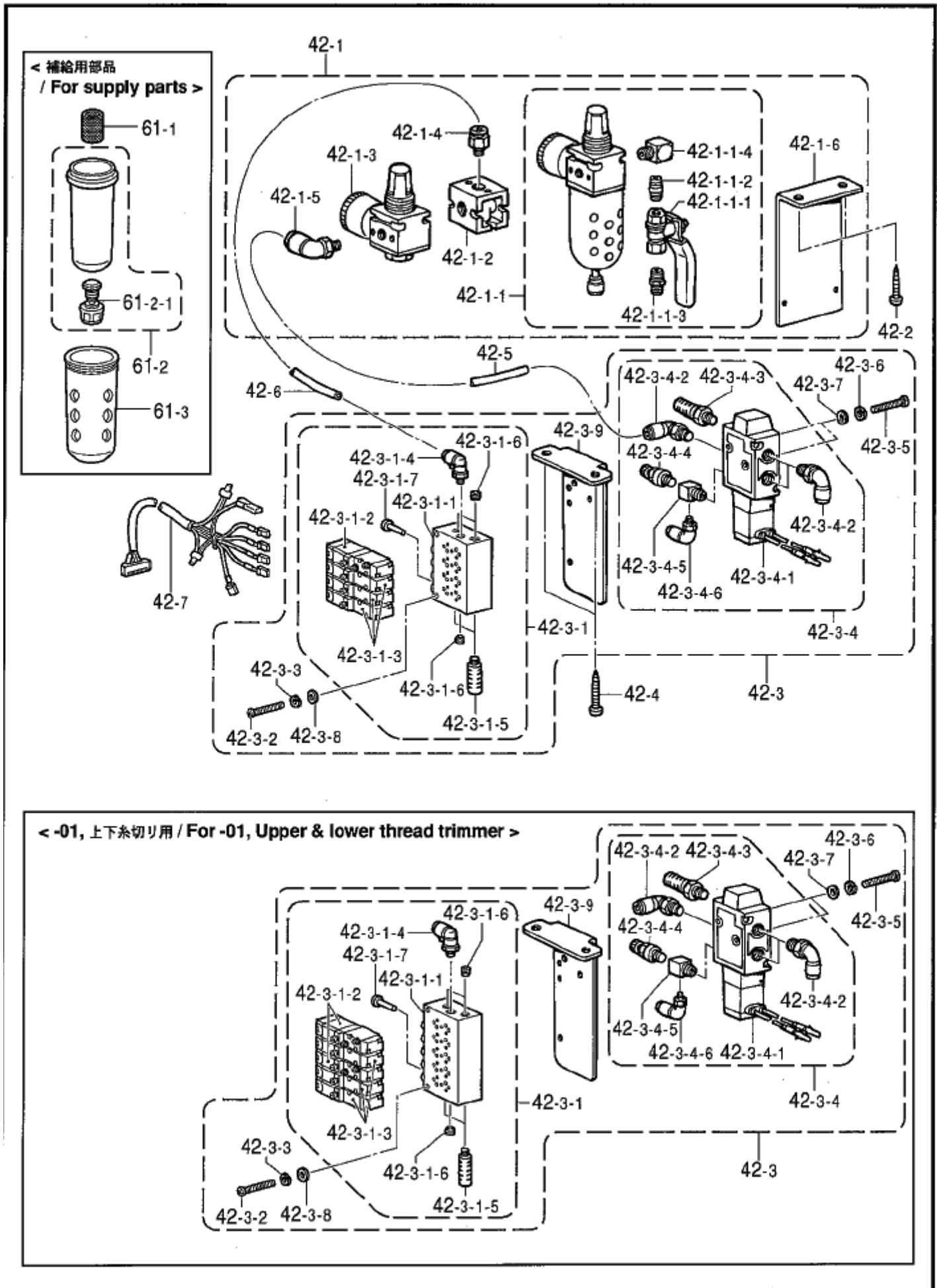

V2 . 空圧関係 / Air pressure mechanism

REF.NO	CODE	Q'TY	ヒンメイ	NAME OF PARTS	RM
42-3-5	062403512	2	ハ ^コ 4X35	SCREW, PAN M4X35	
42-3-6	028040246	2	ハ ^ネ サ ^カ ネ ²⁻⁴	WASHER, SPRING 2-4	
42-3-7	026040136	2	ヒ ^ラ サ ^カ ネ ^カ タ ⁴	WASHER, PLAIN S 4	
42-3-8	026040136	2	ヒ ^ラ サ ^カ ネ ^カ タ ⁴	WASHER, PLAIN S 4	
42-3-9	S44219001	1	ハ ^ル フ ^ト リツケイ	SETTING PLATE, VALVE	
			<補給用部品>	<For supply parts>	
61-1	S46477000	1	フィルタ ^レ メント	FILTER ELEMENT	
61-2	S46478000	1	プ ^ラ スチック ^ホ ウル ^ク ミ	PLASTIC BOWL ASSY	
61-2-1	S46480000	1	ド ^レ ン ^コ ック ^ア SSY	DRAIN COCK ASSY	
61-3	S46479000	1	ホ ^ウ ル ^カ ート	BALL GUARD	

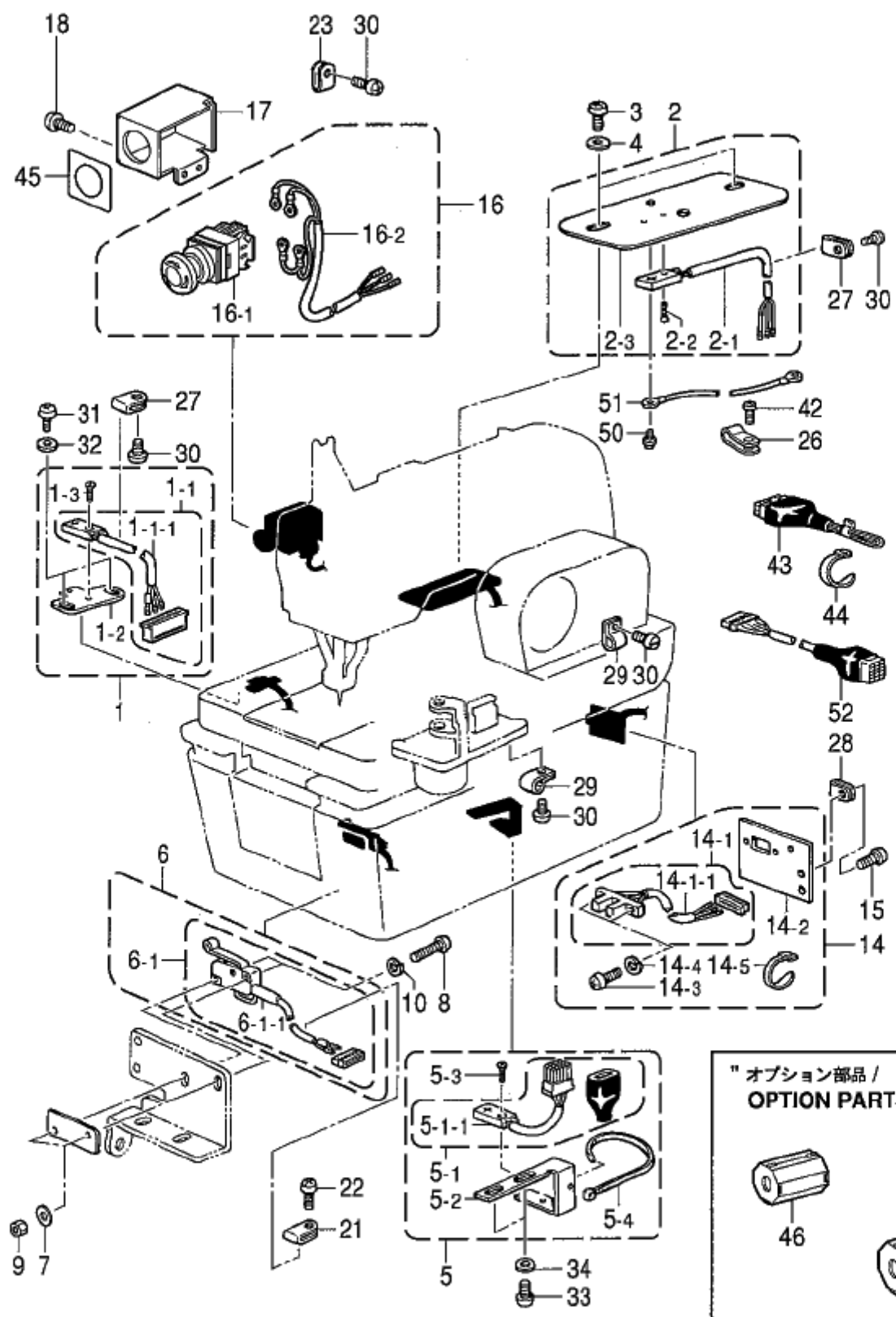

"オプション部品 / OPTION PARTS"

- 46
- 47
- 49

W . 電装品関係 / Power supply equipment mechanism

REF.NO	CODE	Q'TY	ヒンメイ	NAME OF PARTS	RM
1	S43320001	1	XセンサクミB	X-SENSOR ASSY, B	
1-1	S43321000	1	XORGコートクミ	CORD ASSY, XORG	
1-1-1	S43322000	1	XORGコート	CORD, XORG	
1-2	S35185101	1	Xセンサトリツケイタ	SETTING PLATE, ;X-SENSOR	
1-3	S10856001	1	+サラネシ 2X8	SCREW, FLAT M2X8	
2	S43323001	1	YセンサクミB	Y-SENSOR ASSY, B	
2-1	S43324000	1	YORGコート	YORG CORD	
2-2	S10856001	1	+サラネシ 2X8	SCREW, FLAT M2X8	
2-3	S35164101	1	Yセンサトリツケイタ	SETTING PLATE, ;Y-SENSOR	
3	062400812	2	ナハコ4X8	SCREW, PAN M4X8	
4	025040234	2	ヒラサカネチユウ4	WASHER, PLAIN M 4	
5	S43325001	1	RセンサクミB	R-SENSOR ASSY, B	
5-1	S43326000	1	RORGコートクミ	CORD ASSY, RORG	
5-1-1	S35154000	1	Rセンサ	R-SENSOR	
5-2	S35298001	1	Rセンサトリツケイタ	SETTING PLATE, ;R-SENSOR	
5-3	S10856001	1	+サラネシ 2X8	SCREW, FLAT M2X8	
5-4	S04557000	1	バンドPLT1M	BAND, PLT1M	
6	S43328000	1	アンセリンスWコートクミ	CORD ASSY, ;S-SWITCH	
6-1	S43329000	1	アンセリンスWコート	CORD, ;S-SWITCH	
6-1-1	S10546000	1	スイッチD2MVローラ	MICRO SWITCH, ;D2MV ROLLER	
7	025030232	2	ヒラサカネチユウ3	WASHER, PLAIN M 3	
8	062301606	2	ナハコ3X16	SCREW, PAN M3X16	
9	021300206	2	2シユナツト3	NUT, 2 M3	
10	028030243	2	ハネサカネ2-3	WASHER, SPRING 2-3	
14	S45264001	1	カッターセンサクミB-S	CUTTER SENSOR ASSY, B-S	
14-1	S45265000	1	カッターセンサコートクミB	CUTTER SENSOR CORD ASSY, BS	
14-1-1	S45266000	1	カッターセンサコートB-S	CUTTER SENSOR CORD, B-S	
14-2	S35162101	1	カッターセンサトリツケイタ	SETTING PLATE, ;C-SENSOR	
14-3	062300806	2	ナハコ3X8	SCREW, PAN M3X8	
14-4	028030243	2	ハネサカネ2-3	WASHER, SPRING 2-3	
14-5	S04557000	1	バンドPLT1M	BAND, PLT1M	
15	062400812	2	ナハコ4X8	SCREW, PAN M4X8	
16	S43334000	1	EMSW7ミB	EM-SWITCH ASSY, B	
16-1	S32335100	1	SW-AVS311N	SWITCH :AVS311N	
16-2	S43335000	1	EMSWコートB	EM-SWITCH CORD, B	
17	S36651009	1	スイッチカバー-B	SWITCH COVER, B	
18	062400812	2	ナハコ4X8	SCREW, PAN M4X8	
21	625010000	3	ナイロンクランプNK-2N	CORD HOLDER, NK-2N	
22	062400812	3	ナハコ4X8	SCREW, PAN M4X8	
23	S10243000	2	ナイロンクランプNK-3N	CORD HOLDER, NK-3N	
26	149547000	1	コートネジE	CORD HOLDER, 4N	
27	625010000	1	ナイロンクランプNK-2N	CORD HOLDER, NK-2N	
28	S10243000	1	ナイロンクランプNK-3N	CORD HOLDER, NK-3N	
29	552907000	2	コートネジタ#10	CORD HOLDER, 10N	
30	062400812	6	ナハコ4X8	SCREW, PAN M4X8	
31	062400812	3	ナハコ4X8	SCREW, PAN M4X8	
32	025040232	2	ヒラサカネチユウ4	WASHER, PLAIN M 4	
33	062400812	2	ナハコ4X8	SCREW, PAN M4X8	
34	025040232	2	ヒラサカネチユウ4	WASHER, PLAIN M 4	
42	062401212	1	ナハコ4X12	SCREW, PAN M4X12	
43	※	1	981シヨウハーネス	HARNESS, 981	
44	S04557000	2	バンドPLT1M	BAND, PLT1M	
45	S37057001	1	EMスイッチスペーサ3	SPACER, 3 :EM-SWITCH	
50	060400416	1	バンドM4X4	SCREW, BIND M4X4	
51	S44287000	4	アース線1050	GROUND WIRE, 1050	
52	S43358000	1	センサトリツケイコート	CORD, SENSOR	
			”オプション部品”	”OPTION PARTS”	
46	S40621000	9	EMIコアESD-SR-15	EMI CORE, ESD-SR-15	
47	S40622000	2	EMIコアESD-SR-25	EMI CORE, ESD-SR-25	
49	340400001	19	ビーズバンド	BEAD BAND	

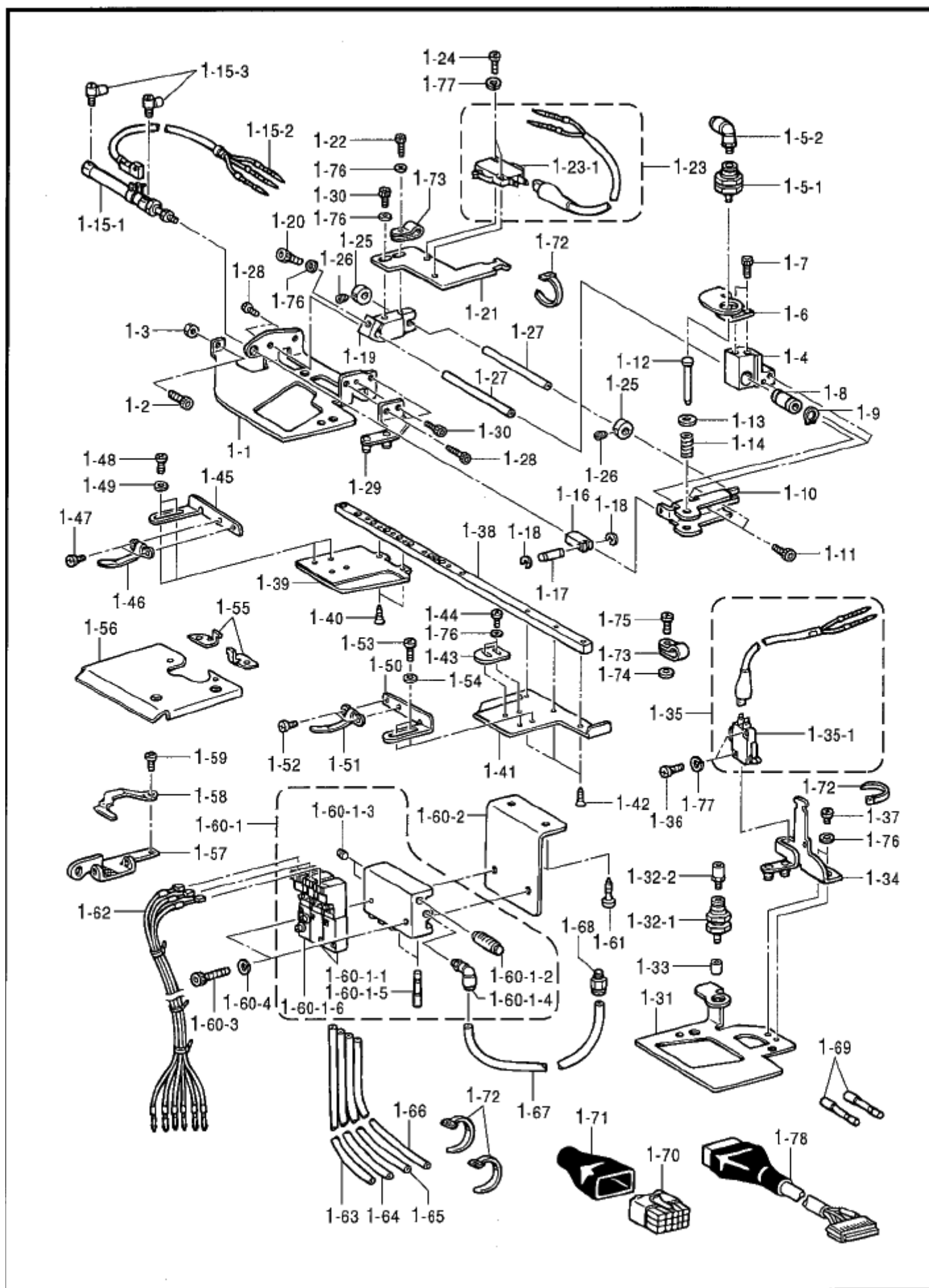

X . 布制御関係 / Cloth control system mechanism

REF.NO	CODE	QTY	ヒンメイ	NAME OF PARTS	RM
1	S44279101	1	<L1,L2,L5用> 981インデクサーソクミ	<For L1,L2,L5> FLY INDEXER ASSY, 981	
1-41	S43809001	1	ヌノクリイタR-L1L2	CLOTH FEED PLATE, ;R-L1,L2	
1	S44281101	1	<L3,L4,L6,L7用> 981インデクサーソクミ	<For L3,L4,L6,L7> FLY INDEXER ASSY, 981	
1-41	S42139101	1	ヌノクリイタR	CLOTH FEED PLATE, R	
1-1	S42111101	1	クリイタイル	FEED BASE, L	
1-2	018501636	1	アホノボルトM5X16	BOLT, SOCKET M5X16	
1-3	021500216	1	2シユナツト5	NUT, 2 M5	
1-4	S42112100	1	クリイタウツロツク	FEED MOVABLE BLOCK	
1-5	S42113000	1	シリンダ10X5エルボクミ	CYLINDER ELBOW ASSY, 10X5	
1-5-1	S42114000	1	シリンダ10X5	CYLINDER, 10X5	
1-5-2	S11426000	1	エルボユニオン4M5	ELBOW UNION, 4M5	
1-6	S42115101	1	シリンダトリツクイタ	SETTING PLATE, ;CYLINDER	
1-7	018401236	2	アホノボルトM4X12	BOLT, SOCKET M4X12	
1-8	S42116000	1	リアホーローボールベアリング	LINEAR BALL BEARING	
1-9	048120142	1	トメワシクヨウC12	RETAINING RING, EXTERNAL C12	
1-10	S42117101	1	チヤツクヒンガイトイタ	GUIDE PLATE, ;C-PIN	
1-11	018401236	2	アホノボルトM4X12	BOLT, SOCKET M4X12	
1-12	S42118001	1	チヤツクピン	PIN	
1-13	026040136	1	ヒラサカネコカクタ	WASHER, PLAIN S 4	
1-14	S42119001	1	オシハネ	SPRING	
1-15	S42120100	1	シリンダ10X60クミ	CYLINDER ASSY, 10X60	
1-15-1	S42121000	1	シリンダ10X60	CYLINDER, 10X60	
1-15-2	S42122000	1	シリンダセンサ	SENSOR, ;CYLINDER	
1-15-3	S12150000	2	ホースエルボM-5HL-4	TUBE ELBOW, M-5HL-4	
1-16	S42123001	1	シリンダロツト	CYLINDER ROD	
1-17	S42124001	1	シリンダロツトピン	ROD PIN, ;CYLINDER	
1-18	048030342	2	トメワシE3	RETAINING RING, E3	
1-19	S42125100	1	クリイタウツロツク	STOPPER BLOCK	
1-20	018401636	1	アホノボルトM4X16	BOLT, SOCKET M4X16	
1-21	S42126101	1	スイッチトリツクイタ	SETTING PLATE, ;SWITCH	
1-22	018401236	1	アホノボルトM4X12	BOLT, SOCKET M4X12	
1-23	S42127000	1	リミットスイッチミル	LIMIT SWITCH ASSY, L	
1-23-1	S36261000	1	スイッチVXロレバ-	MICRO SWITCH, VX ;R-LEVER	
1-24	062301414	2	ナハコM3X14	SCREW, PAN M3X14	
1-25	S24325001	2	セットカラー	SET SCREW COLLAR	
1-26	014400532	2	アホノボルトM4X5	SET SCREW, SOCKET (CP) M4X5	
1-27	S42128101	2	クリイタガイドシャフト	GUIDE SHAFT, ;FEED	
1-28	018401236	4	アホノボルトM4X12	BOLT, SOCKET M4X12	
1-29	S42129101	1	クリイタガイドシャフトクミ	FEED BAR GUIDE ASSY, L	
1-30	018400836	2	アホノボルトM4X8	BOLT, SOCKET M4X8	
1-31	S42132001	1	クリイタイルR	FEED BASE, R	
1-32	S42133000	1	シリンダ10X5クミ	CYLINDER ASSY, 10X5	
1-32-1	S42114000	1	シリンダ10X5	CYLINDER, 10X5	
1-32-2	S11433000	1	ホースニツブ4M5	HOSE NIPPLE, 4M5	
1-33	S05356000	1	ボタンクランプA	BUTTON CLAMP, A	
1-34	S42134101	1	クリイタガイドシャフトクミR	FEED BAR GUIDE ASSY, R	
1-35	S42136000	1	リミットスイッチミルR	LIMIT SWITCH ASSY	
1-35-1	S36261000	1	スイッチVXロレバ-	MICRO SWITCH, VX ;R-LEVER	
1-36	062301414	2	ナハコM3X14	SCREW, PAN M3X14	
1-37	060400516	2	バインドM4X5	SCREW, BIND M4X5	
1-38	S42137001	1	ヌノクリイタ	CLOTH FEED BAR	
1-39	S42138101	1	ヌノクリイタL	CLOTH FEED PLATE, L	
1-40	003300812	2	フラットネジ3X8	SCREW, FLAT M3X8	
1-42	003300812	3	フラットネジ3X8	SCREW, FLAT M3X8	
1-43	S42140100	1	ヌノセットガイドシャフト	CLOTH SET GUIDE, ;VERTICAL	
1-44	060400516	2	バインドM4X5	SCREW, BIND M4X5	
1-45	S42141100	1	ヌノセットガイドシャフトL	CLOTH SET GUIDE, L ;HORIZONTAL	

X. 布制御関係 / Cloth control system mechanism

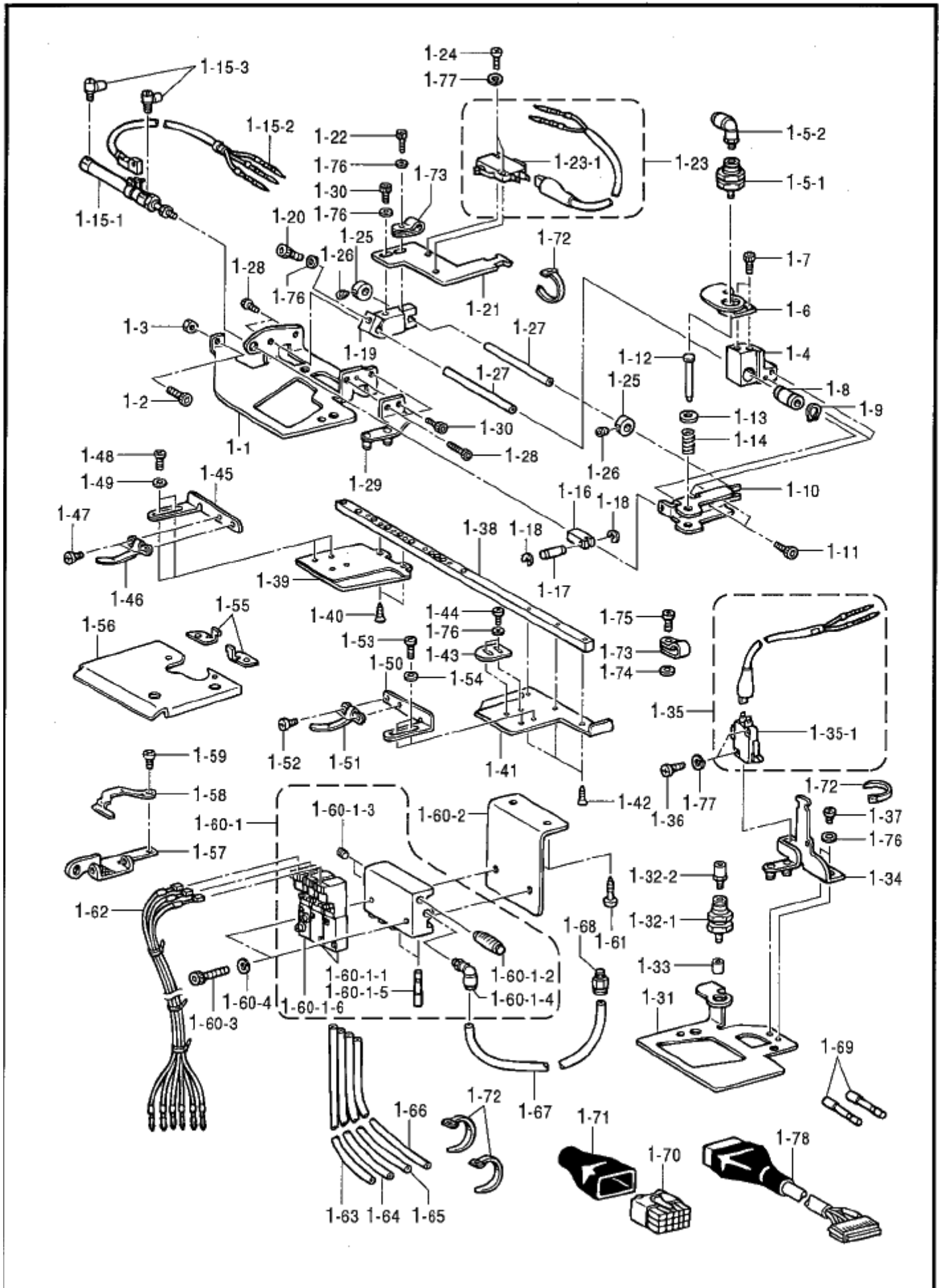

X. 布制御関係 / Cloth control system mechanism

REF.NO	CODE	Q'TY	ヒンメイ	NAME OF PARTS	RM
1-46	S42143100	1	イタハネ	SPRING, PLATE	
1-47	060300416	2	ハ`イント`3X4	SCREW, BIND M3X4	
1-48	060400416	2	ハ`イント`M4X4	SCREW, BIND M4X4	
1-49	025040234	2	ヒラサ`カ`ネチユウ4	WASHER, PLAIN M 4	
1-50	S42142100	1	ヌ/セツカ`ト`ヨR	CLOTH SET GUIDE, R ;HORIZONTAL	
1-51	S42143100	1	イタハネ	SPRING, PLATE	
1-52	060300416	2	ハ`イント`3X4	SCREW, BIND M3X4	
1-53	060400416	2	ハ`イント`M4X4	SCREW, BIND M4X4	
1-54	025040234	2	ヒラサ`カ`ネチユウ4	WASHER, PLAIN M 4	
1-55	S42144101	2	プレートオサI	PLATE PRESSER, I	
1-56	S42145001	1	オサIプレートI	PRESSER PLATE, I	
1-57	S41451001	1	ウイトオサIサI	UPPER THREAD PRESSER SUPPORT	
1-58	S41452000	1	ウイトオサIイ	UPPER THREAD PRESSER PLATE	
1-59	062350516	1	ナ`コ3. 5X5	SCREW, PAN M3.5X5	
1-60	S42146201	1	バルブ`ユニツソクミ	VALVE UNIT SET	
1-60-1	S42147201	1	バルブ`ユニツクミ	VALVE UNIT ASSY	
1-60-1-1	S39115100	2	バルブ`VQZ2151-5	VALVE, VQZ2151-5	
1-60-1-2	140682001	1	サイレンサ	SILENCER	
1-60-1-3	153274001	2	1/8トメセ	CAP, 1/8	
1-60-1-4	S01542000	1	エルボ`ユニオン61	ELBOW UNION, 61	
1-60-1-5	S04897000	2	プラグ`4	PLUG, 4	
1-60-1-6	S39116100	1	バルブ`VQZ2151S-5	VALVE, VQZ2151S-5	
1-60-2	S42148101	1	バルブ`トリツウイ	SETTING PLATE, ;VALVE	
1-60-3	018503036	2	アサホ`ボルト5X30	BOLT, SOCKET M5X30	
1-60-4	028050243	2	ハ`ネサ`カ`ネ2-5	WASHER, SPRING 2-5	
1-61	032422003	2	マルモクネシ`4. 1X20	WOOD SCREW, ROUND M4.1X20	
1-62	S42149000	1	バルブ`ハーネス	VALVE HARNESS	
1-63	S42150100	1	ア`ホ`ホ`4X2. 5-50	AIR TUBE, 4X2.5-50 L=1500	
1-64	S42151100	1	ア`ホ`ホ`4X2. 5-51	AIR TUBE, 4X2.5-51 L=1500	
1-65	S42152100	1	ア`ホ`ホ`4X2. 5-52	AIR TUBE, 4X2.5-52 L=1550	
1-66	S42153000	1	ア`ホ`ホ`4X2. 5-53	AIR TUBE, 4X2.5-53 L=1900	
1-67	S42154000	1	ア`ホ`ホ`6X4	AIR TUBE, 6X4 L=850	
1-68	S01522000	1	ハーフユニオン	HALF UNION	
1-69	S04897000	2	プラグ`4	PLUG, 4	
1-70	S42157000	1	コネクタ5025-15R1	CONNECTOR, 5025-15RT	
1-71	S42158000	1	コネクタキャップ	CONNECTOR CAP	
1-72	S04557000	8	バンドイPLT1M	BAND, PLT1M	
1-73	S00480000	2	コードホルダ`#5	CORD HOLDER, 5N	
1-74	025060236	1	ヒラサ`カ`ネチユウ6	WASHER, PLAIN M 6	
1-75	062401616	1	ナ`コ4X16	SCREW, PAN M4X16	
1-76	025040234	7	ヒラサ`カ`ネチユウ4	WASHER, PLAIN M 4	
1-77	028030243	4	ハ`ネサ`カ`ネ2-3	WASHER, SPRING 2-3	
1-78	S43359000	1	インデックスコード	INDEXER CORD	

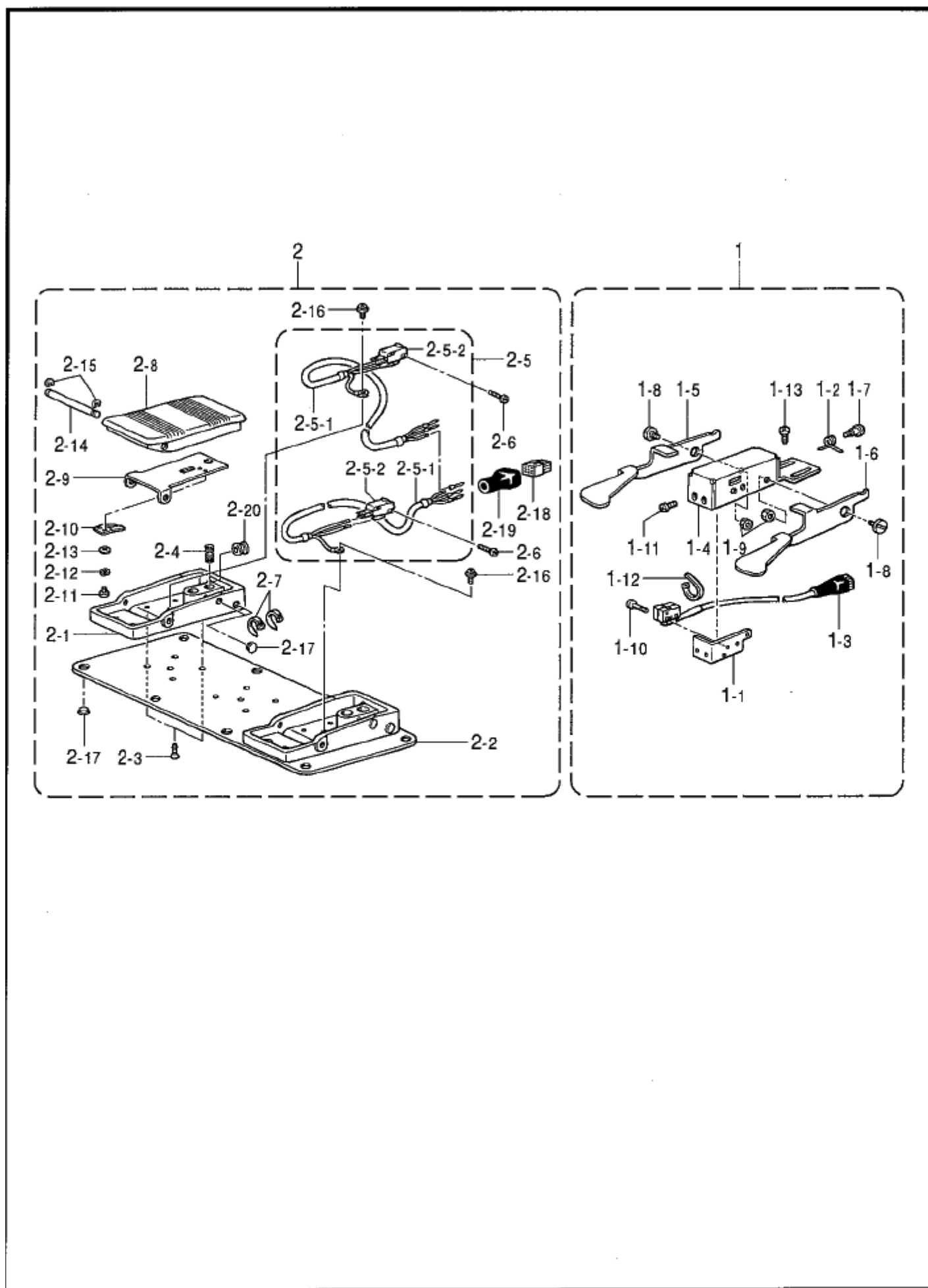

Y. 踏板関係 / Foot switch pedal mechanism

REF.NO	CODE	Q'TY	ヒンメイ	NAME OF PARTS	RM
1	S43346001	1	テトスイッチクミB	HAND START SWITCH ASSY, B	
1-1	S39913001	1	スイッチトリツクイタ	SETTING PLATE, ;SWITCH	
1-2	S39914001	1	スイッチレハ ^ハ ネ	SPRING, ;SWITCH LEVER	
1-3	S43345001	1	テトスイッチB	HAND START SWITCH, B	
1-4	S39910001	1	スイッチカハ ^ハ	SWITCH COVER	
1-5	S39911001	1	スイッチレハ ^ハ -L	SWITCH LEVER, L	
1-6	S39912001	1	スイッチレハ ^ハ -R	SWITCH LEVER, R	
1-7	S34922101	1	タ ^ン ネシ ^ン M4	SHOULDER SCREW, M4	
1-8	S34966001	2	タ ^ン ネシ ^ン M4	SHOULDER SCREW, M4	
1-9	021400202	3	2 ^シ ユナツト4	NUT, 2 M4	
1-10	146124001	2	シメネシ ^ン 2. 38	SCREW, SM2.38	
1-11	060300616	2	ハ ^ハ イント ^ン 3X6	SCREW, BIND M3X6	
1-12	S04557000	1	ハ ^ハ ンタイPLT1M	BAND, PLT1M	
1-13	060400816	2	ハ ^ハ イント ^ン 4X8	SCREW, BIND M4X8	
			<-52,フラインデ ^ン クサ ^ハ 仕様>	<-52,Fly indexer specification>	
2	S42838101	1	2 ^レ ンフツト2SW	2-PEDAL FOOT SWITCH, 2	
2-1	S38166000	2	フツトハ ^ハ タルタ ^ハ イ	FOOT PEDAL BASE	
2-2	S42867001	1	フミイタネシ ^ン ヨイタ	TREADLE AUXILIARY PLATE	
2-3	004400603	4	フサコネシ ^ン 4X6	SCREW, FLAT M4X6	
2-4	S38170001	2	フツトハ ^ハ タルハ ^ハ ネ	SPRING, COMPRESSION	
2-5	S38029000	1	2 ^レ ンフツトSWハ ^ハ ネスクミ	2-PEDAL FOOT SW HARNESS ASSY	
2-5-1	S38030000	2	2 ^レ ンフツトSWハ ^ハ ネス	2-PEDAL FOOT SW HARNESS	
2-5-2	S36260000	2	スイッチVXヒ ^ン ホ ^ン タン	MICRO SWITCH, VX :PIN BUTTON	
2-6	062301205	4	ナ ^ハ コ3X12	SCREW, PAN M3X12	
2-7	228475000	10	ケツクハ ^ハ ント ^ン 1. 9X8	FASTENING BAND, 1.9X80	
2-8	S38174000	2	フツトハ ^ハ タル	FOOT PEDAL	
2-9	S38175001	2	ハ ^ハ タルハ ^ハ コ ^ハ イタ	PROTECTION PLATE, PEDAL	
2-10	S38176101	2	スイッチオサ ^ハ ハ ^ハ ネ	SPRING, PLATE	
2-11	002300403	4	ナ ^ハ コ3X4	SCREW, PAN M3X4	
2-12	028030246	4	ハ ^ハ ネサ ^ハ カ ^ハ ネ2-3	WASHER, SPRING 2-3	
2-13	025030236	4	ヒラサ ^ハ カ ^ハ ネチユ3	WASHER, PLAIN M 3	
2-14	S38177001	2	フツトハ ^ハ タルシ ^ン ク	SHAFT, F-PEDAL	
2-15	048050346	4	トメ ^ハ E5	RETAINING RING, E5	
2-16	052400606	2	ナ ^ハ コハ ^ハ ネヒラ4X6	SCREW, PAN (S/P WASHER) M4X6	
2-17	117936001	12	ゴ ^ハ ムセン9. 4	RUBBER CAP, 9.4	
2-18	S38180000	1	コネクタ172169-1	CONNECTOR, 172169-1	
2-19	S38060000	1	コネクタキヤツ ^ン 18X19	CONNECTOR CAP, 18X19	
2-20	S38059000	2	ク ^ハ ロメツトNG79F	RUBBER CAP, NG79F	

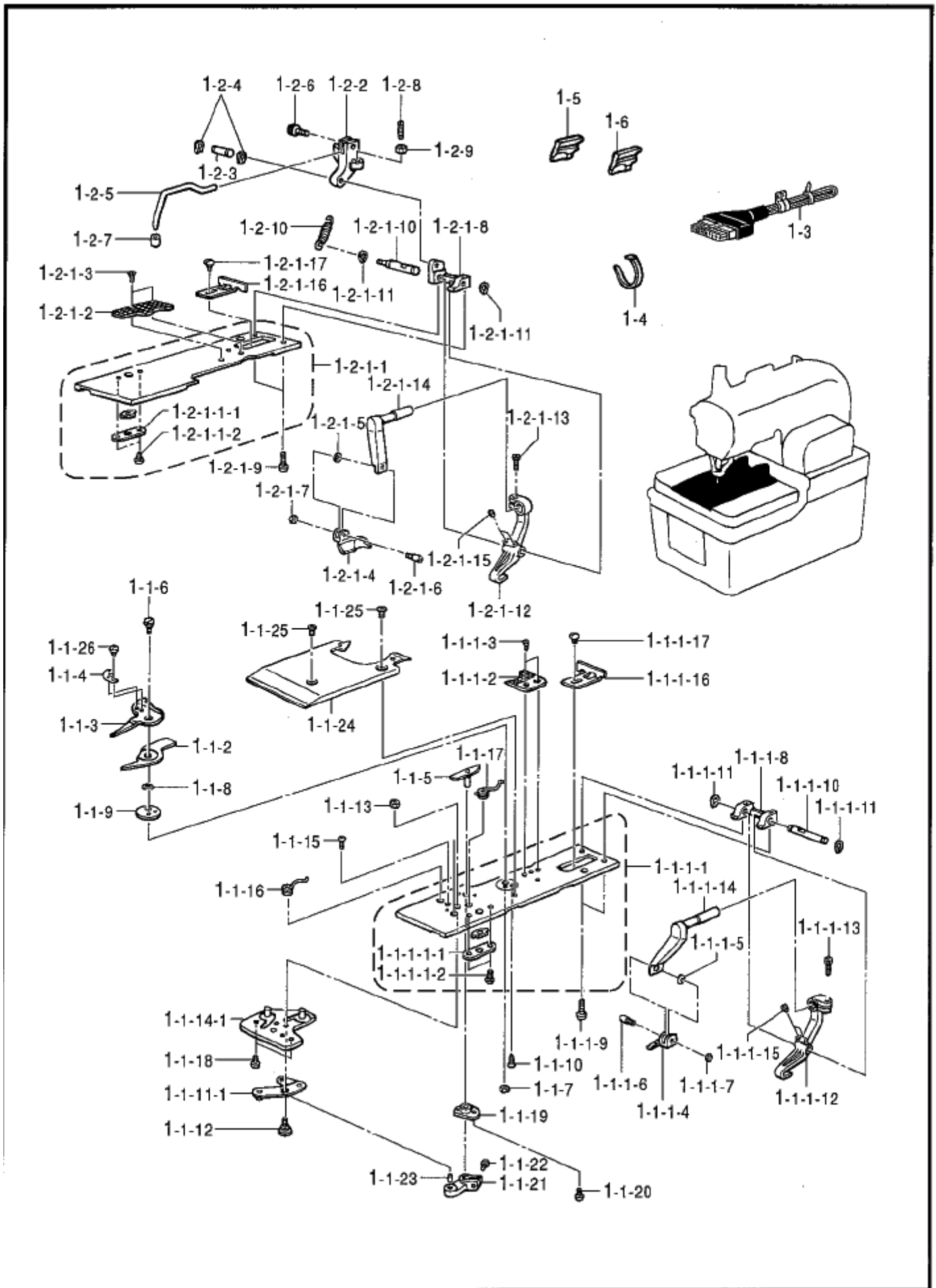

AA1 . 付属装置関係 / Attachment set

REF.NO	CODE	Q'TY	ヒンメイ	NAME OF PARTS	RM
1	※	1	クミカ7°ヒンペツ(L※)	EXCHANGE PARTS SET, L※	
1-1	※	1	L※プレートRクミ	L※ PLATE ASSY, R	
1-1-1	※	1	オIプレートJR※ソクミ	WORK CLAMP PLATE SET, JR※	
1-1-1-1	S37729101	1	<L1-L4 14-30mm> ヌ/オI7°プレートJRクミ	<L1-L4 14-30mm> WORK CLAMP PLATE ASSY, JR	
1-1-1-1	S40828001	1	<L5-L7 28-40mm> ヌ/オI7°プレートJRクミB	<L5-L7 28-40mm> WORK CLAMP PLATE ASSY, JR ;B	
1-1-1-1-1	S35315001	1	ヒラキカクマ	SLIDE BLOCK, ;OPENING	
1-1-1-1-2	060020416	2	ハ°イント°M2X4	SCREW, BIND M2X4	
1-1-1-2	※	1	ハIイ丸※R	NEEDLE PLATE, R L※	
1-1-1-3	S06696004	2	サコネシ°3X6	SCREW, FLAT M3X6	
1-1-1-4	※	1	ヌ/オI7°R-JL※	WORK CLAMP, R-J L※	
1-1-1-5	S35236000	1	マ°サ°カ°ネ.2	WASHER, BENDING 3.2	
1-1-1-6	S35235001	1	クランプ°サIヒ°ン	SUPPORT PIN, ;CLAMP	
1-1-1-7	021300302	1	3シユナツト3	NUT, 3 M3	
1-1-1-8	S35238001	1	クランプ°シ°クウケ	SHAFT HOLDER, ;CLAMP	
1-1-1-9	062401016	2	ハ°コ4X10	SCREW, PAN M4X10	
1-1-1-10	S35237001	1	クランプ°シテングク	FULCRUM SHAFT, ;CLAMP	
1-1-1-11	048050142	2	トメウシ°クヨウC5	RETAINING RING, C5	
1-1-1-12	S35234201	1	クランプ°レハ°R	CLAMP LEVER, R	
1-1-1-13	018501236	1	アホ°ネト5X12	BOLT, SOCKET M5X12	
1-1-1-14	S37695001	1	<L1-L4 14-30mm> クランプ°ア°R-J	<L1-L4 14-30mm> CLAMP ARM, R-J	
1-1-1-14	S40826001	1	<L5-L7 28-40mm> クランプ°ア°R-J-B	<L5-L7 28-40mm> CLAMP ARM, R-J-B	
1-1-1-15	014400532	2	アナホ°ミ4X5	SET SCREW, SOCKET (CP) M4X5	
1-1-1-16	S35347100	1	ヌ/カ°ト°R	CLOTH GUIDE, R	
1-1-1-17	060350616	1	ハ°イント°3.5X6	SCREW, BIND M3.5X6	
1-1-2	※	1	ト°ウ丸※R	MOVABLE KNIFE, R L※	
1-1-3	※	1	ト°ウ丸※L	MOVABLE KNIFE, L L※	
1-1-4	※	1	トサハ°キL※	THREAD HANDLER, L※	
1-1-5	※	1	ト°ウウツ°ウカL※	MOVABLE KNIFE DRIVING CAM, L※	
1-1-6	S37660101	1	ダンネシ°M4	SHOULDER SCREW, M4	
1-1-7	021400202	1	2シユナツト4	NUT, 2 M4	
1-1-8	S37654000	1	ナミサ°ガ°ネ	WASHER, WAVE	
1-1-9	S37655101	1	ヌササIサ°ガ°ネ	WASHER, ;KNIFE SUPPORT	
1-1-10	141542001	2	サラネシ°3.18	SCREW 3.18	
1-1-11-1	S37656001	1	トキリリンクレハ°-Jクミ	T-TRIMMER LINK LEVER ASSY, J	
1-1-12	S34881001	1	ダンネシ°M4	SHOULDER SCREW, M4	
1-1-13	021400202	1	2シユナツト4	NUT, 2 M4	
1-1-14-1	S37820001	1	リンクシテンプ°プレートクミ	LINK FULCRUM PLATE ASSY	
1-1-15	062400616	2	ハ°コM4X6	SCREW, PAN M4X6	
1-1-16	S37652001	1	ト°シハ°ネL	SPRING, L TWIST	
1-1-17	S37653001	1	ト°シハ°ネR	SPRING, R TWIST	
1-1-18	062300416	2	ハ°コM3X4	SCREW, PAN M3X4	
1-1-19	S34906100	1	トキリウテ°メタル	BUSH, ;TR TRIMMER ARM	
1-1-20	062260612	2	ハ°コ2.6X6	SCREW, PAN M2.6X6	
1-1-21	S37659001	1	トキリレハ°ウテ°B	THREAD TRIMMER LEVER ARM, B	
1-1-22	S21716001	1	ホ°タンヘッド°ネシ°4X1	SCREW, BUTTON HEAD M4X10	
1-1-23	S37858000	1	ニト°ル°ン4X8	NEEDLE PIN, 4X8	
1-1-24	S56025001	1	オIプレートU	PRESSER PLATE, U	
1-1-25	060400516	2	ハ°イント°M4X5	SCREW, BIND M4X5	
1-1-26	153787001	2	シメネシ°2.38	SCREW, SM2.38	

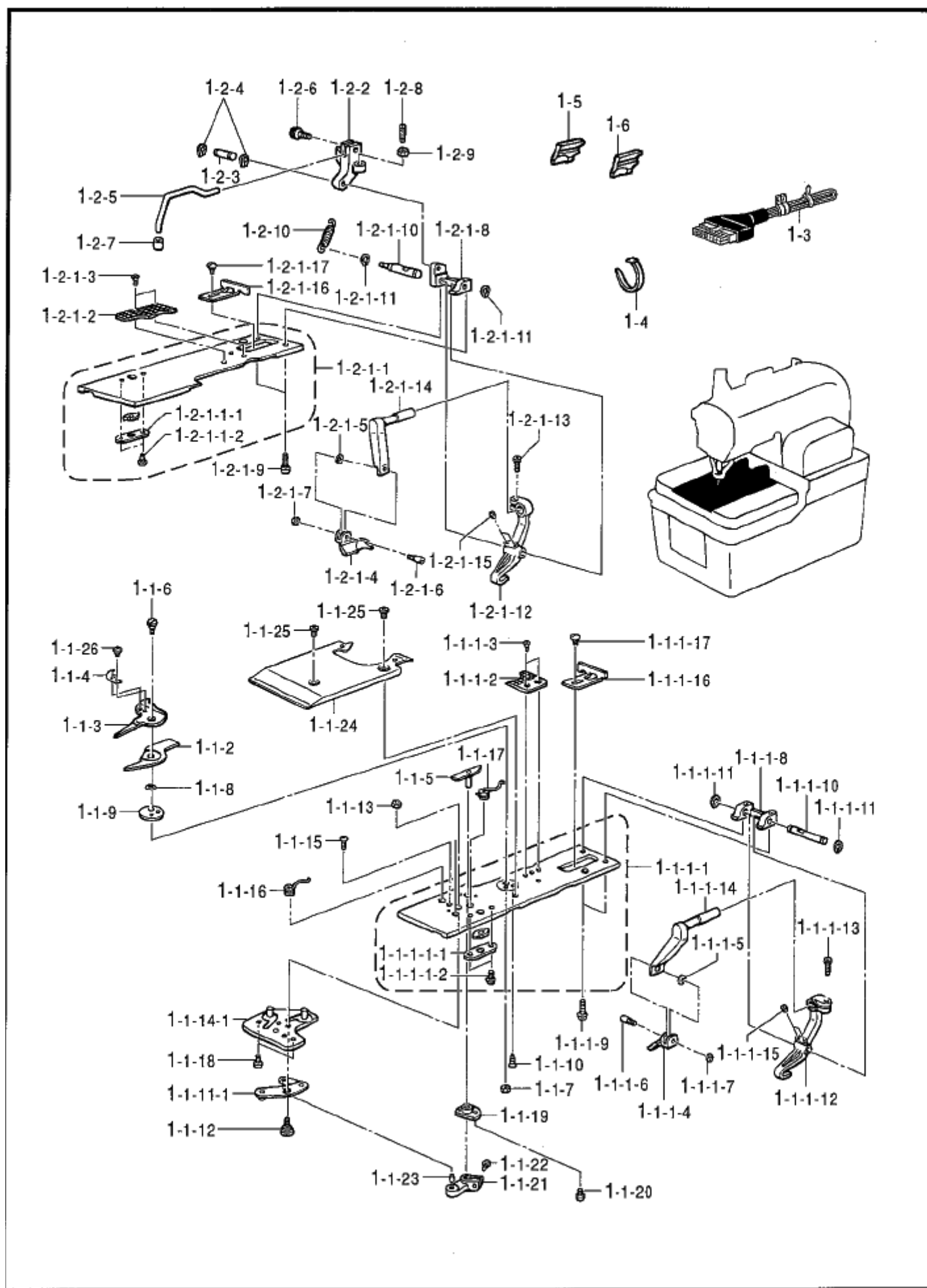

AA1 . 付属装置関係 / Attachment set .

REF.NO	CODE	QTY	ヒンメイ	NAME OF PARTS	RM
1-2	※	1	L※プレートLクミ	L※ PLATE ASSY, L	
1-2-1	※	1	材エプレートJL※ソウクミ	WORK CLAMP PLATE SET, J L※	
1-2-1-1	S37730001	1	<L1-L4 14-30mm> 材エプレートJLクミ	<L1-L4 14-30mm> WORK CLAMP PLATE ASSY, JL	
1-2-1-1	S35310001	1	<L5-L7 28-40mm> 材エプレートLクミ	<L5-L7 28-40mm> WORK CLAMP PLATE ASSY, L	
1-2-1-1-1	S35316001	1	カコマサエイタ	SUPPORT PLATE, ;S-BLOCK	
1-2-1-1-2	060020416	2	バインド M2X4	SCREW, BIND M2X4	
1-2-1-2	※	1	ルイタL※	NEEDLE PLATE, L L※	
1-2-1-3	S06696004	2	サコネジ 3X6	SCREW, FLAT M3X6	
1-2-1-4	※	1	材エプレートJL※	WORK CLAMP, L-J L※	
1-2-1-5	S35236000	1	ワサガネ 3.2	WASHER, BENDING 3.2	
1-2-1-6	S35235001	1	クランプサビピン	SUPPORT PIN, ;CLAMP	
1-2-1-7	021300302	1	3ユナグト3	NUT, 3 M3	
1-2-1-8	S37712001	1	クランプシャフト	CLAMP SHAFT HOLDER	
1-2-1-9	062401016	2	パネコ4X10	SCREW, PAN M4X10	
1-2-1-10	S37711001	1	クランプシャフト	CLAMP FULCRUM SHAFT	
1-2-1-11	048050142	2	トメワシクヨウC5	RETAINING RING, C5	
1-2-1-12	S35233201	1	クランプレバ L	CLAMP LEVER, L	
1-2-1-13	018501236	1	アサネ 5X12	BOLT, SOCKET M5X12	
1-2-1-14	S37694001	1	<L1-L4 14-30mm> クランプアーム L-J	<L1-L4 14-30mm> CLAMP ARM, L-J	
1-2-1-14	S40827001	1	<L5-L7 28-40mm> クランプアーム L-J-B	<L5-L7 28-40mm> CLAMP ARM, L-J-B	
1-2-1-15	014400532	2	アサネ 4X5	SET SCREW, SOCKET (CP) M4X5	
1-2-1-16	S35348100	1	材ガイド L	CLOTH GUIDE, L	
1-2-1-17	060350616	1	バインド 3.5X6	SCREW, BIND M3.5X6	
1-2-2	S37714001	1	材ヨサエシャフト	FULCRUM BRACKET, ;AUX.CLAMP	
1-2-3	S37713001	1	材ヨサエシャフト	FULCRUM SHAFT, ;AUX.CLAMP	
1-2-4	048050142	2	トメワシクヨウC5	RETAINING RING, C5	
1-2-5	S37718000	1	材ヨサエアーム	AUXILIARY CLAMP ARM	
1-2-6	018401032	1	アサネ 4X10	BOLT, SOCKET M4X10	
1-2-7	S05356000	1	ボタンサマ	BUTTON CLAMP, A	
1-2-8	S08808001	1	ストップネジ	STOPPER SCREW	
1-2-9	021660102	1	ナット 1.8	NUT, 1 SM3.18	
1-2-10	S37753001	1	材ヨサエバネ	SPRING, EXTENSION	
1-3	※	1	981シヨウハーネスL1	HARNESS, 981 L1	
1-4	S04557000	1	バンド(PLT1M)	BAND, PLT1M	
1-5	※	1	ハンマー	HAMMER	
1-6	※	1	ハンマー	HAMMER	

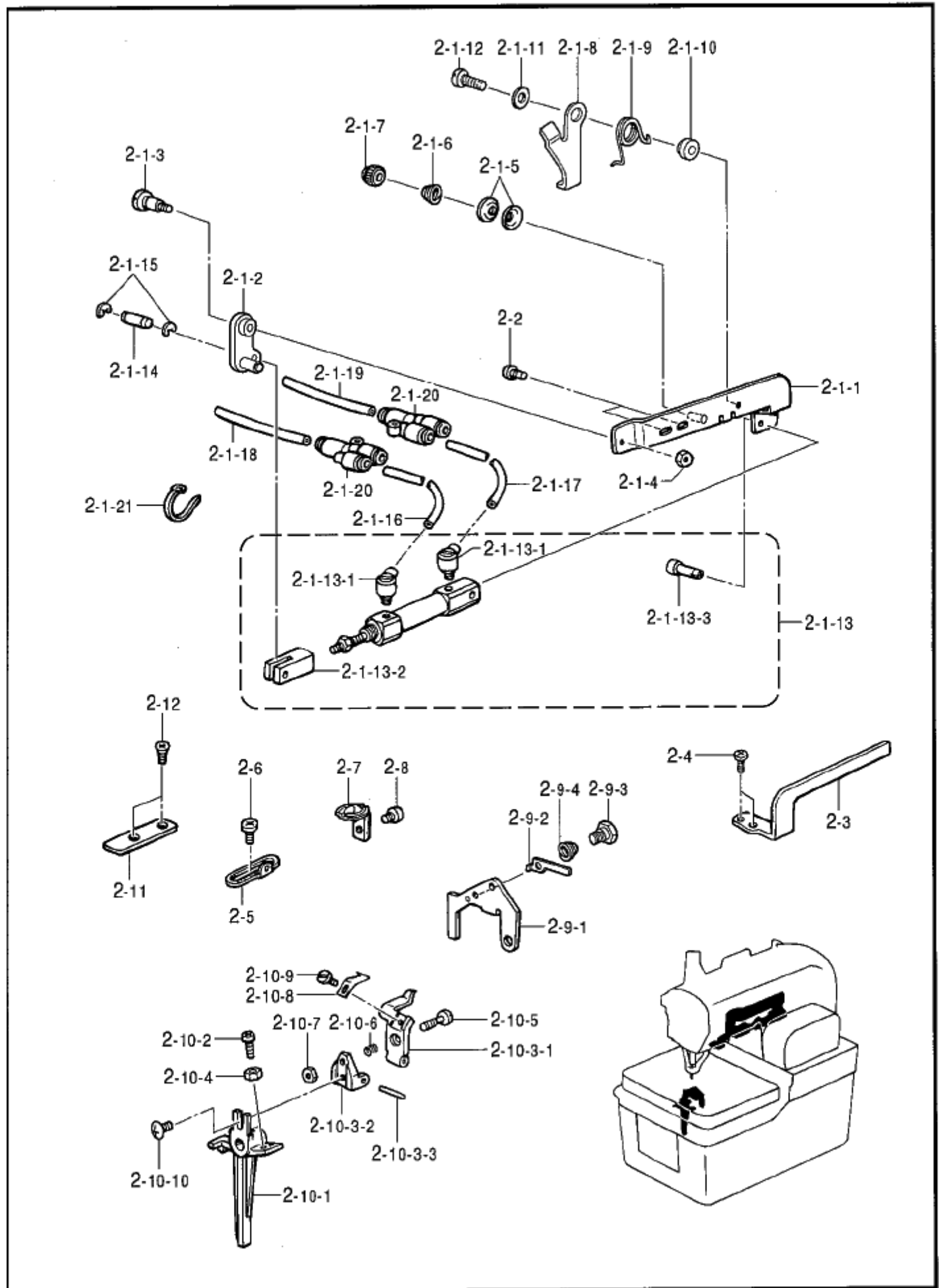

AA2 . 付属装置関係 / Attachment set .

REF.NO	CODE	QTY	ヒンメイ	NAME OF PARTS	RM
2	S38584001	1	クミカブヒンクミ(-2)	EXCHANGE PARTS SET, -2	
2-1	S38585001	1	シリンダサエクミ	CYLINDER SUPPORT SET	
2-1-1	S37744001	1	Fサエシリンダサエクミ	CYLINDER SUPPORT ASSY	
2-1-2	S37717101	1	ホシヨサエリンククミ	AUX. CLAMP LINK ASSY	
2-1-3	S34922101	1	ダンネシ M4	SHOULDER SCREW, M4	
2-1-4	021400202	1	2シユナツト4	NUT, 2 M4	
2-1-5	144504001	2	トアンナイサテ	DISC, THREAD GUIDE	
2-1-6	154562001	1	プレンシヨシハ 裃	SPRING, B :PRE-TENSION	
2-1-7	155510001	1	トチヨウシナツト	TENSION NUT	
2-1-8	S51219001	1	シイトルメイタ	TENSION RELEASE PLATE, ;GIMP	
2-1-9	S37749001	1	シイトルメイタハネ	SPRING, TWIST	
2-1-10	S51220001	1	カラ	COLLAR	
2-1-11	025040332	1	ヒラサガネ 裃 4	WASHER, PLAIN L 4	
2-1-12	062401212	1	ハコ 4X12	SCREW, PAN M4X12	
2-1-13	S37737001	1	シリンダ 10X15Jクミ	CYLINDER ASSY, 10X15J	
2-1-13-1	S12150000	2	ホスエルホ M-5HL-4	TUBE ELBOW, M-5HL-4	
2-1-13-2	S35351001	1	シリンダロツト	CYLINDER ROD	
2-1-13-3	S37866000	1	クレビスピン	CLEVIS PIN	
2-1-14	S35305001	1	シリンダロツトピン	ROD PIN, ;CYLINDER	
2-1-15	048030342	2	トメワ3	RETAINING RING, E3	
2-1-16	S37738000	1	IA-ホス4X2.5-20	AIR TUBE, 4X2.5-20 L=1350	
2-1-17	S37739000	1	IA-ホス4X2.5-21	AIR TUBE, 4X2.5-21 L=1400	
2-1-18	S37863000	1	IA-ホス4X2.5-3J	AIR TUBE, 4X2.5-3J L=100	
2-1-19	S37864000	1	IA-ホス4X2.5-4J	AIR TUBE, 4X2.5-4J L=100	
2-1-20	S12104000	2	エオンア4	UNION, Y 4	
2-1-21	S04557000	1	バンタイPLT1M	BAND, PLT1M	
2-2	062400812	2	ハコ 4X8	SCREW, PAN M4X8	
2-3	S37750001	1	シイトリアンナイJ	TR TAKE-UP GUIDE, J ;GIMP	
2-4	062400812	2	ハコ 4X8	SCREW, PAN M4X8	
2-5	S37697001	1	シイトアンナイJ	THREAD GUIDE, J ;GIMP	
2-6	062400812	1	ハコ 4X8	SCREW, PAN M4X8	
2-7	S37752001	1	スロートプレート1.8-J	THROAT PLATE, 1.8-J	
2-8	S35326001	1	シメネシ M3.5	SCREW, M3.5	
2-9	S39109101	1	シイトアンナイC-Jクミ	GIMP GUIDE ASSY, C-J	
2-9-1	S37696101	1	シイトアンナイC-J	GIMP GUIDE, C-J	
2-9-2	S41252000	1	シイトサエイタ-J	GIMP THREAD CLAMP PLATE, J	
2-9-3	159113001	1	ダンネシ 3.18	SHOULDER SCREW, SM3.18	
2-9-4	S35118001	1	ハリトチヨウシハネ	TENSION SPRING	
2-10	S39108001	1	レハートタイバクミ	LEVER BRACKET ASSY, B	
2-10-1	S37726001	1	トキリレハートタイバ	T-TRIMMER LEVER BRACKET, B	
2-10-2	062301016	1	ハコ M3X10	SCREW, PAN M3X10	
2-10-3	S47512001	1	シイトサエIJクミ	LOWER THREAD PRESSER ASSY, J	
2-10-3-1	S37720001	1	シイトサエI	LOWER THREAD PRESSER	
2-10-3-2	S37721001	1	シイトサエIタイ	LOWER THREAD PRESSER BRACKET	
2-10-3-3	148407001	1	ヨアンナイミソピン	DOWEL PIN, L	
2-10-4	021300302	1	3シユナツト3	NUT, 3 M3	
2-10-5	S37724001	1	シメネシ 2.38	SCREW, SM2.38	
2-10-6	S37725001	1	シイトサエIハネ	SPRING, COMPRESSION	
2-10-7	S47932001	1	ナツト238-56	NUT, SM2.38-56	
2-10-8	S37723001	1	ウイトウハB	MOVABLE KNIFE, B ;UPPER	
2-10-9	105288001	1	シメネシ 2.38	SCREW, SM2.38	
2-10-10	060350616	1	ハイント 3.5X6	SCREW, BIND M3.5X6	
2-11	S37693001	1	プレートカイトイC	GUIDE PLATE, C	
2-12	S06696004	2	フラコネシ 3X6	SCREW, FLAT M3X6	

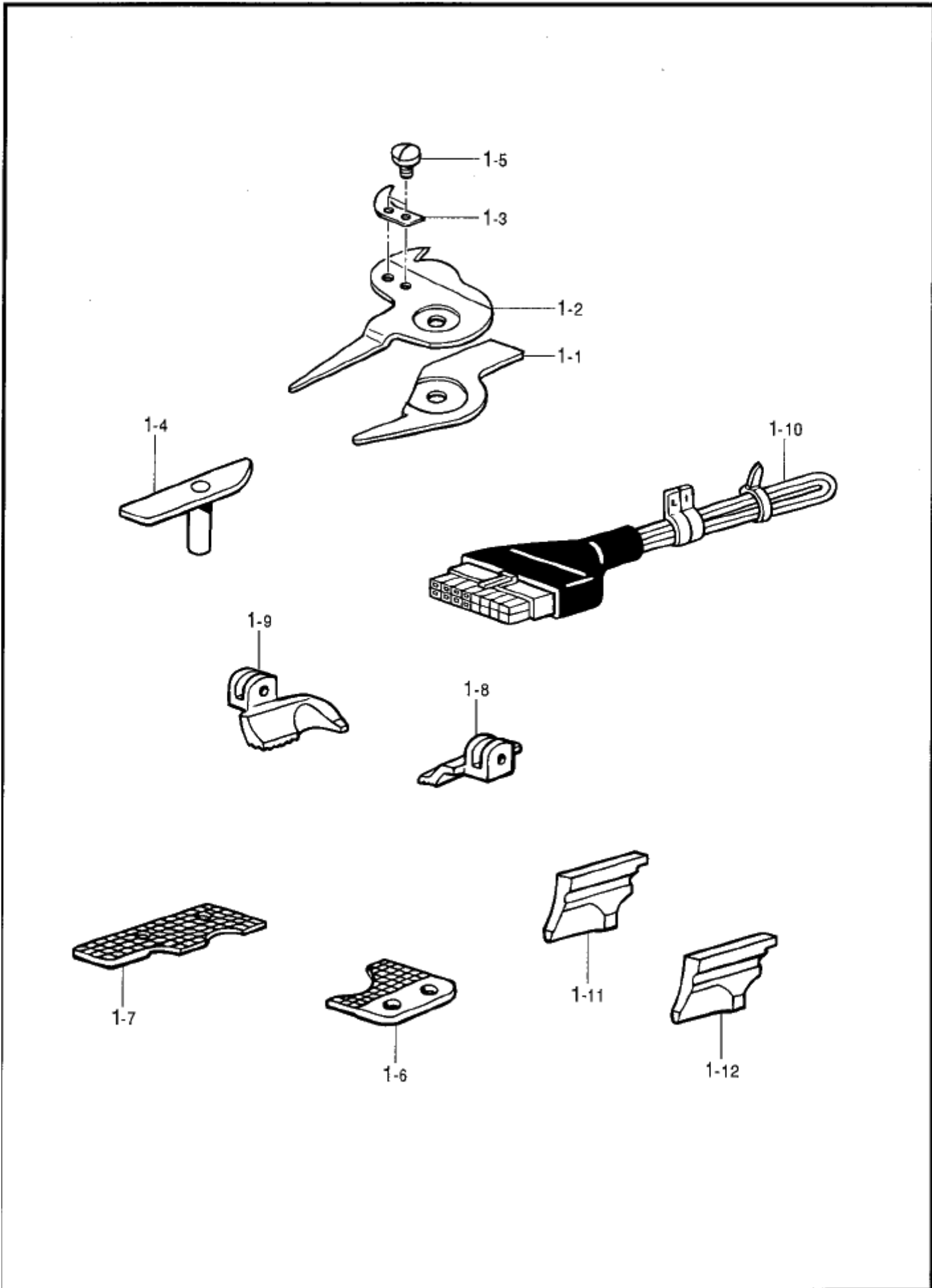

AA3 . 付属装置関係 / Attachment set .

REF.NO	CODE	QTY	ヒンメイ	NAME OF PARTS	RM
			<L1 14-18mm>	<L1 14-18mm>	
1	S44275001	1	コウカンハ ^o -ツL1クミ	EXCHANGE PARTS ASSY, L1	
1-1	S37673101	1	ト ^o ウL1R	MOVABLE KNIFE, R L1	
1-2	S37669101	1	ト ^o ウL1L	MOVABLE KNIFE, L L1	
1-3	S37665000	1	トサハ ^o キL1	THREAD HANDLER, L1	
1-4	S37661101	1	ト ^o ウハツ ^o ウカL1	MOVABLE KNIFE DRIVING CAM, L1	
1-5	153787001	2	シメネシ ^o 2.38	SCREW, SM2.38	
1-6	S37644101	1	ハリイタL1R	NEEDLE PLATE, R L1	
1-7	S37643201	1	ハリイタL1L	NEEDLE PLATE, L L1	
1-8	S37754001	1	ヌノオサI ^o R-JL1	WORK CLAMP, R-J L1	
1-9	S37755001	1	ヌノオサI ^o L-JL1	WORK CLAMP, L-J L1	
1-10	S43337000	1	981シヨウハ ^o ネスL1	HARNES, 981 L1	
1-11	S37702001	1	ハンマ-S12	HAMMER, S12	
1-12	S37704001	1	ハンマ-S16	HAMMER, S16	
			<L2 18-22mm>	<L2 18-22mm>	
1	S44276001	1	コウカンハ ^o -ツL2クミ	EXCHANGE PARTS ASSY, L2	
1-1	S37674101	1	ト ^o ウL2R	MOVABLE KNIFE, R L2	
1-2	S37670101	1	ト ^o ウL2L	MOVABLE KNIFE, L L2	
1-3	S37666000	1	トサハ ^o キL2	THREAD HANDLER, L2	
1-4	S37662101	1	ト ^o ウハツ ^o ウカL2	MOVABLE KNIFE DRIVING CAM, L2	
1-5	153787001	2	シメネシ ^o 2.38	SCREW, SM2.38	
1-6	S37646101	1	ハリイタL2R	NEEDLE PLATE, R L2	
1-7	S37645201	1	ハリイタL2L	NEEDLE PLATE, L L2	
1-8	S37690001	1	ヌノオサI ^o R-JL2	WORK CLAMP, R-J L2	
1-9	S37689001	1	ヌノオサI ^o L-JL2	WORK CLAMP, L-J L2	
1-10	S43338000	1	981シヨウハ ^o ネスL2	HARNES, 981 L2	
1-11	S37704001	1	ハンマ-S16	HAMMER, S16	
1-12	S37706001	1	ハンマ-S20	HAMMER, S20	
			<L3 22-26mm>	<L3 22-26mm>	
1	S44277001	1	コウカンハ ^o -ツL3クミ	EXCHANGE PARTS ASSY, L3	
1-1	S37675101	1	ト ^o ウL3R	MOVABLE KNIFE, R L3	
1-2	S37671101	1	ト ^o ウL3L	MOVABLE KNIFE, L L3	
1-3	S37667000	1	トサハ ^o キL3	THREAD HANDLER, L3	
1-4	S37663101	1	ト ^o ウハツ ^o ウカL3	MOVABLE KNIFE DRIVING CAM, L3	
1-5	153787001	2	シメネシ ^o 2.38	SCREW, SM2.38	
1-6	S37648101	1	ハリイタL3R	NEEDLE PLATE, R L3	
1-7	S37647101	1	ハリイタL3L	NEEDLE PLATE, L L3	
1-8	S37692001	1	ヌノオサI ^o R-JL3	WORK CLAMP, R-J L3	
1-9	S37691001	1	ヌノオサI ^o L-JL3	WORK CLAMP, L-J L3	
1-10	S43339000	1	981シヨウハ ^o ネスL3	HARNES, 981 L3	
1-11	S37706001	1	ハンマ-S20	HAMMER, S20	
1-12	S37708001	1	ハンマ-S24	HAMMER, S24	
			<L4 26-30mm>	<L4 26-30mm>	
1	S44278001	1	コウカンハ ^o -ツL4クミ	EXCHANGE PARTS ASSY, L4	
1-1	S37676101	1	ト ^o ウL4R	MOVABLE KNIFE, R L4	
1-2	S37672101	1	ト ^o ウL4L	MOVABLE KNIFE, L L4	
1-3	S37668000	1	トサハ ^o キL4	THREAD HANDLER, L4	
1-4	S37664101	1	ト ^o ウハツ ^o ウカL4	MOVABLE KNIFE DRIVING CAM, L4	
1-5	153787001	2	シメネシ ^o 2.38	SCREW, SM2.38	
1-6	S37650101	1	ハリイタL4R	NEEDLE PLATE, R L4	
1-7	S37649101	1	ハリイタL4L	NEEDLE PLATE, L L4	
1-8	S37758001	1	ヌノオサI ^o R-JL4	WORK CLAMP, R-J L4	
1-9	S37759001	1	ヌノオサI ^o L-JL4	WORK CLAMP, L-J L4	
1-10	S43340000	1	981シヨウハ ^o ネスL4	HARNES, 981 L4	
1-11	S37708001	1	ハンマ-S24	HAMMER, S24	
1-12	S42053001	1	ハンマ-S28	HAMMER, S28	

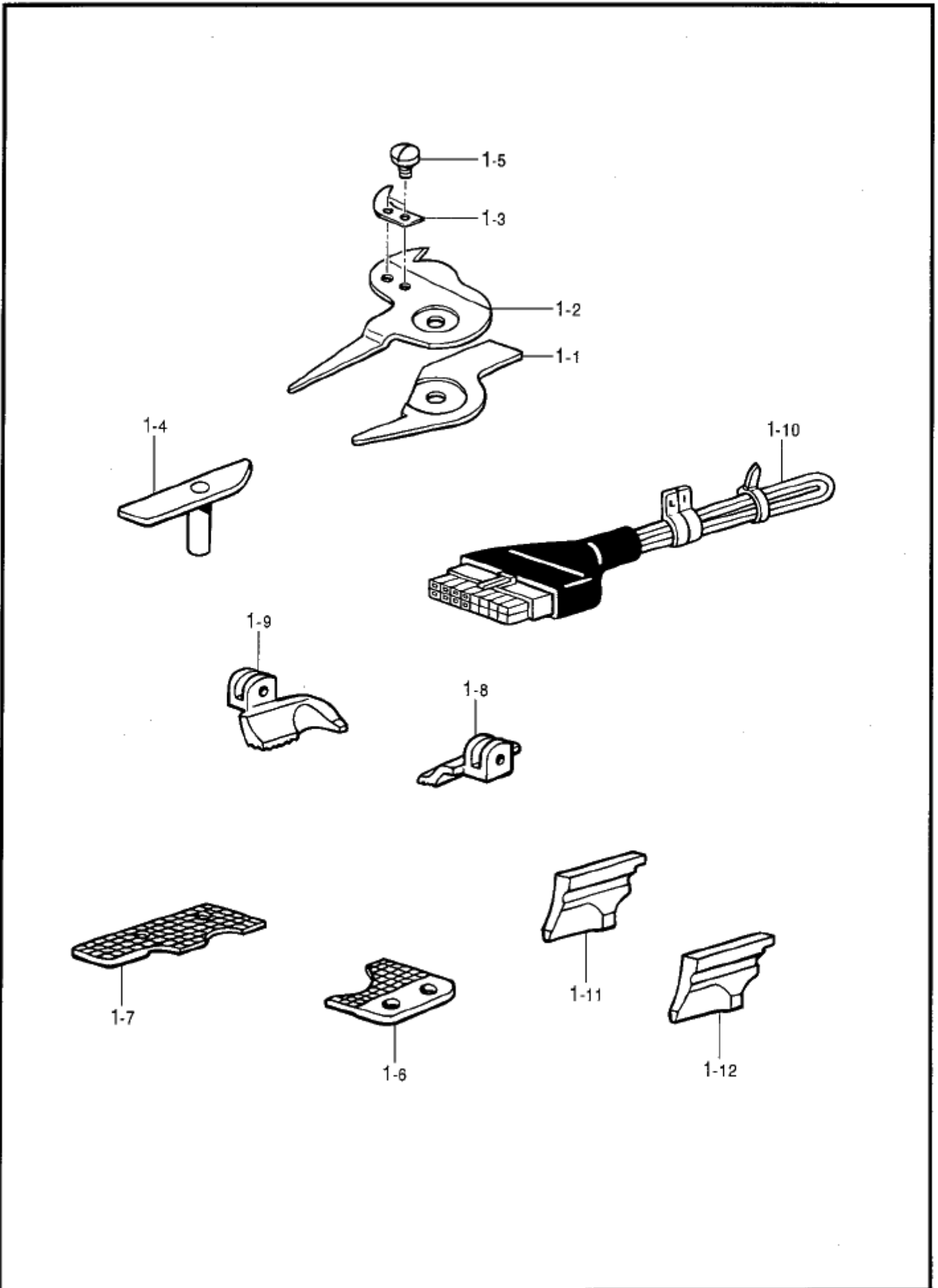

AA3 . 付属装置関係 / Attachment set .

REF.NO	CODE	Q'TY	ヒンメイ	NAME OF PARTS	RM
1	S44283001	1	<L5 28-32mm> コウカンパ ^o -ツL5クミ	<L5 28-32mm> EXCHANGE PARTS ASSY, L5	
1-1	S37674101	1	イト ^o ウL2R	MOVABLE KNIFE, R L2	
1-2	S37670101	1	イト ^o ウL2L	MOVABLE KNIFE, L L2	
1-3	S37666000	1	イトサハ ^o キL2	THREAD HANDLER, L2	
1-4	S37662101	1	イト ^o ウハウト ^o ウカムL2	MOVABLE KNIFE DRIVING CAM, L2	
1-5	153787001	2	シメネジ ^o 2.38	SCREW, SM2.38	
1-6	S40822001	1	ハライタL5R	NEEDLE PLATE, R L5	
1-7	S40823001	1	ハライタL5L	NEEDLE PLATE, L L5	
1-8	S41483001	1	ヌノオサIR-JL5	WORK CLAMP, R-J L5	
1-9	S41484001	1	ヌノオサIL-JL5	WORK CLAMP, L-J L5	
1-10	S43341000	1	981シヨウハ-ネスL5	HARNES, 981 L5	
1-11	S37197001	1	ハンマ-26	HAMMER, 26	
1-12	S37199001	1	ハンマ-30	HAMMER, 30	
1	S44284001	1	<L6 32-36mm> コウカンパ ^o -ツL6クミ	<L6 32-36mm> EXCHANGE PARTS ASSY, L6	
1-1	S37675101	1	イト ^o ウL3R	MOVABLE KNIFE, R L3	
1-2	S37671101	1	イト ^o ウL3L	MOVABLE KNIFE, L L3	
1-3	S37667000	1	イトサハ ^o キL3	THREAD HANDLER, L3	
1-4	S37663101	1	イト ^o ウハウト ^o ウカムL3	MOVABLE KNIFE DRIVING CAM, L3	
1-5	153787001	2	シメネジ ^o 2.38	SCREW, SM2.38	
1-6	S41479001	1	ハライタL6R	NEEDLE PLATE, R L6	
1-7	S41480001	1	ハライタL6L	NEEDLE PLATE, L L6	
1-8	S41485001	1	ヌノオサIR-JL6	WORK CLAMP, R-J L6	
1-9	S41486001	1	ヌノオサIL-JL6	WORK CLAMP, L-J L6	
1-10	S43342000	1	981シヨウハ-ネスL6	HARNES, 981 L6	
1-11	S37199001	1	ハンマ-30	HAMMER, 30	
1-12	S37201001	1	ハンマ-34	HAMMER, 34	
1	S44285001	1	<L7 36-40mm> コウカンパ ^o -ツL7クミ	<L7 36-40mm> EXCHANGE PARTS ASSY, L7	
1-1	S37676101	1	イト ^o ウL4R	MOVABLE KNIFE, R L4	
1-2	S37672101	1	イト ^o ウL4L	MOVABLE KNIFE, L L4	
1-3	S37668000	1	イトサハ ^o キL4	THREAD HANDLER, L4	
1-4	S37664101	1	イト ^o ウハウト ^o ウカムL4	MOVABLE KNIFE DRIVING CAM, L4	
1-5	153787001	2	シメネジ ^o 2.38	SCREW, SM2.38	
1-6	S41481001	1	ハライタL7R	NEEDLE PLATE, R L7	
1-7	S41482001	1	ハライタL7L	NEEDLE PLATE, L L7	
1-8	S41487001	1	ヌノオサIR-JL7	WORK CLAMP, R-J L7	
1-9	S41488001	1	ヌノオサIL-JL7	WORK CLAMP, L-J L7	
1-10	S43343000	1	981シヨウハ-ネスL7	HARNES, 981 L7	
1-11	S37201001	1	ハンマ-34	HAMMER, 34	
1-12	S35093001	1	ハンマ-38	HAMMER, 38	

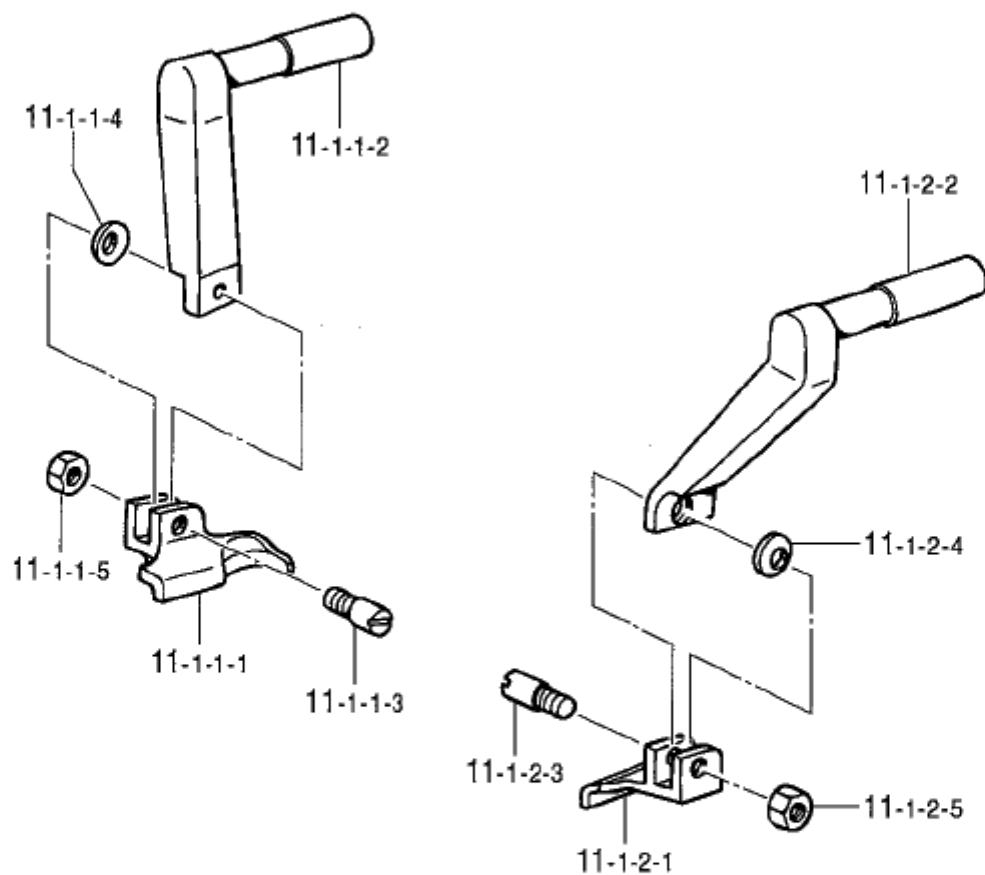

AA4 . 付属装置関係 / Attachment set .

REF.NO	CODE	QTY	ヒンメイ	NAME OF PARTS	RM
			<ウエストベルト押IL3用>	<For waist belt presser, L3>	
11-1	S43701001	1	ヌノオサIL3Wセット	WORK CLAMP SET, L3W	
11-1-1	S43702001	1	ヌノオサIL-L3Wクミ	WORK CLAMP ASSY, L-L3W	
11-1-1-1	S43408001	1	ヌノオサIL-L3W	WORK CLAMP, L-L3W	
11-1-1-2	S43450001	1	クランプア-IL-JW	CLAMP ARM, L-JW	
11-1-1-3	S35235001	1	クランプササヒピン	SUPPORT PIN, ;CLAMP	
11-1-1-4	S35236000	1	ワッシャー 3.2	WASHER, BENDING 3.2	
11-1-1-5	021300302	1	ナット 3	NUT, 3 M3	
11-1-2	S43703001	1	ヌノオサIR-L3Wクミ	WORK CLAMP ASSY, R-L3W	
11-1-2-1	S43409001	1	ヌノオサIR-L3W	WORK CLAMP, R-L3W	
11-1-2-2	S43451001	1	クランプア-IR-JW	CLAMP ARM, R-JW	
11-1-2-3	S35235001	1	クランプササヒピン	SUPPORT PIN, ;CLAMP	
11-1-2-4	S35236000	1	ワッシャー 3.2	WASHER, BENDING 3.2	
11-1-2-5	021300302	1	ナット 3	NUT, 3 M3	
			<ウエストベルト押IL4用>	<For waist belt presser, L4>	
11-1	S43704001	1	ヌノオサIL4Wセット	WORK CLAMP SET, L4W	
11-1-1	S43705001	1	ヌノオサIL-L4Wクミ	WORK CLAMP ASSY, L-L4W	
11-1-1-1	S43410001	1	ヌノオサIL-L4W	WORK CLAMP, L-L4W	
11-1-1-2	S43450001	1	クランプア-IL-JW	CLAMP ARM, L-JW	
11-1-1-3	S35235001	1	クランプササヒピン	SUPPORT PIN, ;CLAMP	
11-1-1-4	S35236000	1	ワッシャー 3.2	WASHER, BENDING 3.2	
11-1-1-5	021300302	1	ナット 3	NUT, 3 M3	
11-1-2	S43706001	1	ヌノオサIR-L4Wクミ	WORK CLAMP ASSY, R-L4W	
11-1-2-1	S43411001	1	ヌノオサIR-L4W	WORK CLAMP, R-L4W	
11-1-2-2	S43451001	1	クランプア-IR-JW	CLAMP ARM, R-JW	
11-1-2-3	S35235001	1	クランプササヒピン	SUPPORT PIN, ;CLAMP	
11-1-2-4	S35236000	1	ワッシャー 3.2	WASHER, BENDING 3.2	
11-1-2-5	021300302	1	ナット 3	NUT, 3 M3	

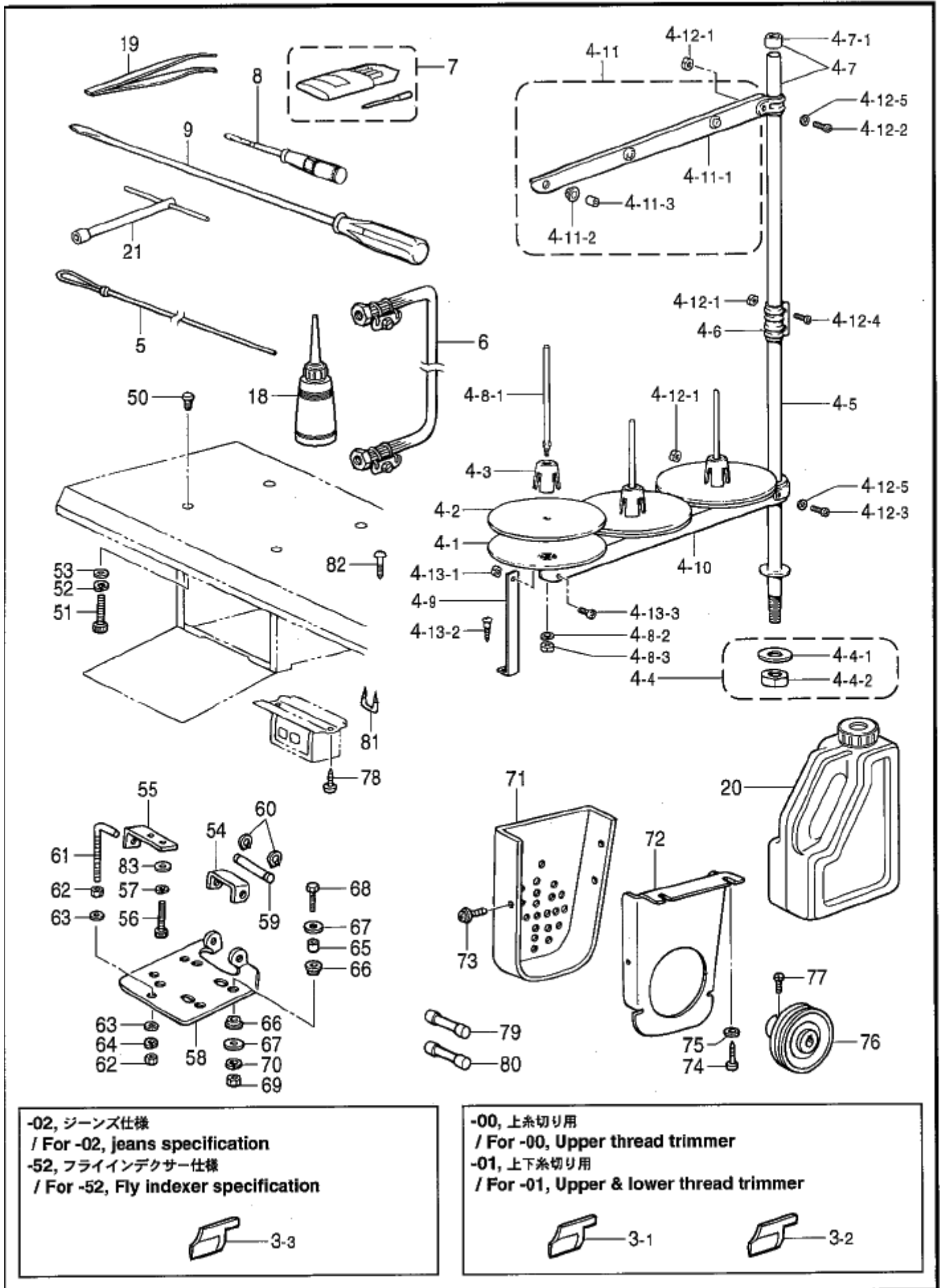

Z. 付属品関係 / Accessories

REF.NO	CODE	Q'TY	ヒンメイ	NAME OF PARTS	RM
			<-00, 上糸切り用>	<For-00, Upper thread trimmer>	
3-1	S35092001		<-01, 上下糸切り用>	<For-01, Upper & lower thread trimmer>	
3-2	S37197001		ハンマ-20	HAMMER, 20	
			ハンマ-26	HAMMER, 26	
			<-02, ジーンズ仕様>	<For-02, jeans specification>	
			<-52, フライインデクサー仕様>	<For-52, Fly indexer specification>	
3-3	S37704001		ハンマ-S16.....L1	HAMMER, S16.....L1	
3-3	S37706001		ハンマ-S20.....L2	HAMMER, S20.....L2	
3-3	S37708001		ハンマ-S24.....L3	HAMMER, S24.....L3	
3-3	S42053001		ハンマ-S28.....L4	HAMMER, S28.....L4	
3-3	S37199001		ハンマ-30.....L5	HAMMER, 30.....L5	
3-3	S37201001		ハンマ-34.....L6	HAMMER, 34.....L6	
3-3	S35093001		ハンマ-38.....L7	HAMMER, 38.....L7	
4	S02766209	1	イトタテイキ3D	COTTON STAND ASSY, 3D	
4-1	S51283001	3	ウサラ	SPOOL STAND BASE	
4-2	150182000	3	スプ-ルマット	SPOOL MAT	
4-3	S51282001	3	スプ-ルクッション	SPOOL CUSHION	
4-4	S02775001	1	パイフネジセットA	PIPE SCREW SET, A	
4-4-1	150206002	1	ヒラサガネ16	WASHER, PLAIN 16	
4-4-2	S38648001	1	6角ナットU5/8	NUT, U5/8-28	
4-5	156112003	1	コラムパイフD	COLUMN PIPE, D	
4-6	150173003	1	コラムジョイント	COLUMN JOINT	
4-7	S40640001	1	コラムパイフキャップ付き	COLUMN PIPE W/CAP	
4-7-1	150174000	1	コラムキャップ	COLUMN CAP	
4-8	S21798001	3	スプ-ルネジセット	SPOOL & SCREW SET	
4-8-1	150179002	3	スプ-ルシャフトB	SPOOL SHAFT, B	
4-8-2	028050246	3	パイネジカネ2-5	WASHER, SPRING 2-5	
4-8-3	021500106	3	1号ナット5	NUT, 1 M5	
4-9	150188009	1	スプ-ルホルダ-サシア	SPOOL HOLDER SUPPORT, A	
4-10	S02779009	1	スプ-ルホルダ-3	SPOOL HOLDER, 3	
4-11	S02788009	1	スレッドハンガ-クミ3	THREAD HANGER ASSY, 3	
4-11-1	S02789009	1	スレッドハンガ-3	THREAD HANGER, 3	
4-11-2	150183000	3	イトカハンガ-タイ	THREAD HANGER BASE	
4-11-3	142990001	3	スレッドブッシュ	THREAD BUSH	
4-12	S40641001	1	スプ-ルシャフトネジセット	SPOOL SHAFT & SCREW SET, A	
4-12-1	021500106	4	1号ナット5	NUT, 1 M5	
4-12-2	062501406	1	ナハコ5X14	SCREW, PAN M5X14	
4-12-3	S59931001	1	ナハコM5X32	SCREW, PAN M5X32	
4-12-4	062501406	2	ナハコ5X14	SCREW, PAN M5X14	
4-12-5	S30302000	1	ポリバッグ70	PE. BAG, 70X70	
4-12-6	026050136	2	ヒラサガネコタ5	WASHER, PLAIN S 5	
4-13	S40644001	1	ホルダ-ツキネジセット	HOLDER JOINT & SCREW SET	
4-13-1	021500106	1	1号ナット5	NUT, 1 M5	
4-13-2	031452206	1	丸木ネジ4.5X22	WOOD SCREW, ROUND M4.5X22	
4-13-3	062501006	1	ナハコ5X10	SCREW, PAN M5X10	
5	S34915000	1	イトオシ	THREADER	
6	149796001	1	ゴムホースカクツキ	AIR HOSE, W/CONNECTOR	
			<-00, 上糸切り用>	<For-00, Upper thread trimmer>	
7	S35133116	1	ミシンハリDOX558針...<#16>	NEEDLE ASSY, DOX558 (#16)	
			<-01, 上下糸切り用>	<For-01, Upper & lower thread trimmer>	
7	S35133114	1	ミシンハリDOX558針...<#14>	NEEDLE ASSY, DOX558 (#14)	
			<-02, ジーンズ仕様>	<For-02, jeans specification>	
7	S35133118	1	ミシンハリDOX558針...<#18>	NEEDLE ASSY, DOX558 (#18)	
8	118837001	1	ネジマワリ3.4X70	SCREW DRIVER, 3.4X70	
9	101572101	1	ネジマワリ5.5X190	SCREW DRIVER, 5.5X190	
10	107779001	1	スパナ6X7	WRENCH, 6X7	

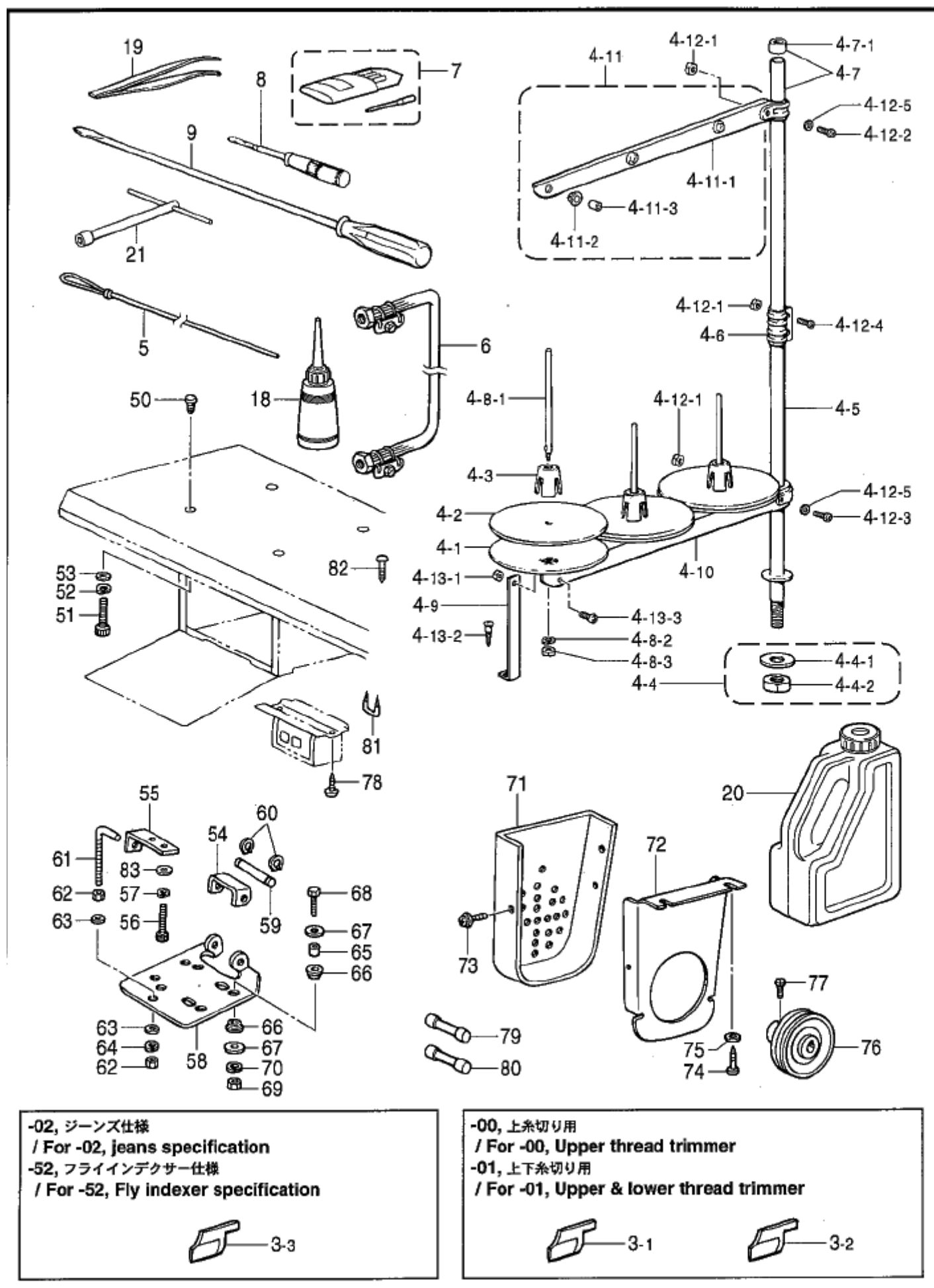

-02, ジーンズ仕様
 / For -02, jeans specification
 -52, フライインデクサー仕様
 / For -52, Fly indexer specification



-00, 上糸切り用
 / For -00, Upper thread trimmer
 -01, 上下糸切り用
 / For -01, Upper & lower thread trimmer



Z. 付属品関係 / Accessories

REF.NO	CODE	Q'TY	ヒンメイ	NAME OF PARTS	RM
11	100887001	1	スハ ^ナ 8X9	WRENCH, 8X9	
12	107780001	1	スハ ^ナ 10X12	WRENCH, 10X12	
13	142002001	1	6カクホ ^{ウスハ} ナ2	HEXAGONAL WRENCH, 2	
14	142721001	1	6カクホ ^{ウスハ} ナ3	HEXAGONAL WRENCH, 3	
15	118064001	1	6カクホ ^{ウスハ} ナ4	HEXAGONAL WRENCH, 4	
16	150335001	1	6カクホ ^{ウスハ} ナ5	HEXAGONAL WRENCH, 5	
17	115157001	1	6カクホ ^{ウスハ} ナ6	HEXAGONAL WRENCH, 6	
18	114483002	1	ホ ^リ オイル ^ラ グミ	OILER ASSY	
19	117466000	1	ピン ^セ ット	PINCETTE	
20	S55663001	1	オイル ^{タン} ク ^グ ミ	OIL TANK ASSY	
21	140342001	1	ソ ^ク ツ ^レ ン ^チ グ ^ミ	SOCKET WRENCH ASSY	
23	018084032	4	ア ^ナ ホ ^{ルト} 8X40	BOLT, SOCKET M8X40	
24	028080242	4	ハ ^ネ サ ^カ ネ ² -8	WASHER, SPRING 2-8	
25	025080232	4	ヒ ^ラ サ ^カ ネ ^ユ ウ ⁸	WASHER, PLAIN M 8	
26	159150000	4	ゴ ^ム セン ^{20.5}	RUBBER CAP, 20.5	
50	S43729000	8	オ ^メ ナ ^ツ ト ¹ -M6X20	NUT	
51	018065022	4	ア ^ナ ホ ^{ルト} 6X50	BOLT, SOCKET M6X50	
52	028060242	4	ハ ^ネ サ ^カ ネ ² -6	WASHER, SPRING 2-6	
53	122257001	4	サ ^カ ネ	WASHER	
54	S43715001	1	モ ^タ シ ^イ タ	MOTOR PLATE	
55	S43716001	1	リ ^カ タ ^ホ ルト ^シ イ ^タ	HOLDER PLATE, ; BOLT	
56	018065022	4	ア ^ナ ホ ^{ルト} 6X50	BOLT, SOCKET M6X50	
57	028060242	4	ハ ^ネ サ ^カ ネ ² -6	WASHER, SPRING 2-6	
58	152861101	1	モ ^タ イ	MOTOR BASE PLATE	
59	152862001	1	モ ^タ イ ^シ ク	MOTOR BASE PLATE SHAFT	
60	048100142	2	ト ^メ シ ^ク ウ ^ウ C10	RETAINING RING, EXTERNAL C10	
61	152865201	1	リ ^カ タ ^ホ ルト ^{M10}	BOLT, L-TYPE M10	
62	021100202	2	ナ ^ツ ト ² シ ^ユ 10	NUT, 2 M10	
63	025100132	2	ヒ ^ラ サ ^カ ネ ^シ ヨ ^ウ 10	WASHER, PLAIN S 10	
64	028100242	1	ハ ^ネ サ ^カ ネ ² -10	WASHER, SPRING 2-10	
65	152863001	4	ク ^ツ シ ^ヨ ン ^カ ラ	CUSHION COLLAR	
66	152864000	8	ク ^ツ シ ^ヨ ン	CUSHION	
67	025800332	8	ヒ ^ラ サ ^カ ネ ^タ 17.14	WASHER, PLAIN L 7.14	
68	017062503	4	6カクホ ^{ルト} 6X25	BOLT, M6X25	
69	021060106	4	1シ ^ユ ナ ^ツ ト ⁶	NUT, 1 M6	
70	028060242	4	ハ ^ネ サ ^カ ネ ² -6	WASHER, SPRING 2-6	
71	S43714000	1	モ ^タ カ ^ハ -981	MOTOR COVER, 981	
72	S43713001	1	モ ^タ ウ ^シ ロ ^カ ハ ^サ サ ^イ	MOTOR REAR COVER SUPPORT	
73	052400806	3	ナ ^ハ コ ^ハ ネ ^ヒ ラ ⁴ X ⁸	SCREW, PAN (S/P WASHER) M4X8	
74	101118001	2	マ ^ル モ ^ク ネ ^シ 4.5X20	WOOD SCREW, ROUND M4.5X20	
75	025050232	2	ヒ ^ラ サ ^カ ネ ^ユ ウ ⁵	WASHER, PLAIN M 5	
76	S38041000	1	モ ^タ プ ^リ	MOTOR PULLEY	
77	105073001	1	ア ^タ マ ^ツ キ ^ト メ ^ネ シ 5.95	SET SCREW, SM5.95	
78	032461606	2	+マ ^ル モ ^ク ネ ^シ 4.5X16	WOOD SCREW, ROUND M4.5X16	
79	S08030000	1	フ ^ィ ユ ^{ース} 5AFB	FUSE, 5A :FB	
80	153242000	1	フ ^ィ ユ ^{ース} 6A	FUSE, 6A	
81	200190001	4	ス ^テ ツ ^フ ル	STAPLE	
82	032422505	4	+マ ^ル モ ^ク ネ ^シ 4.1X25	WOOD SCREW, ROUND M4.1X25	
83	025060332	4	ヒ ^ラ サ ^カ ネ ^タ 16	WASHER, PLAIN L 6	

Sp1. 仕様別部品一覧表 / DIFFERENT PARTS LIST

REF. NO.	L1 14-18mm	L2 18-22mm	L3 22-26mm	L4 26-30mm
AA1	S44238-001	S44239-001	S44240-001	S44271-001
-1	クミカエピンセット (L1)	クミカエピンセット (L2)	クミカエピンセット (L3)	クミカエピンセット (L4)
	EXCHANGE PARTS SET, L1	EXCHANGE PARTS SET, L2	EXCHANGE PARTS SET, L3	EXCHANGE PARTS SET, L4
AA1	S38576-401	S38578-401	S38580-401	S38582-401
-1-1	L1 プレート Rクミ	L2 プレート Rクミ	L3 プレート Rクミ	L4 プレート Rクミ
	L1 PLATE ASSY, R	L2 PLATE ASSY, R	L3 PLATE ASSY, R	L4 PLATE ASSY, R
AA1	S37756-401	S37727-401	S37733-401	S37757-401
-1-1-1	オサエプレート JR1ソククミ	オサエプレート JR2ソククミ	オサエプレート JR3ソククミ	オサエプレート JR4ソククミ
	WORK CLAMP PLATE SET, J R1	WORK CLAMP PLATE SET, J R2	WORK CLAMP PLATE SET, J R3	WORK CLAMP PLATE SET, J R4
AA1	S37644-101	S37646-101	S37648-101	S37650-101
-1-1-1-2	ハリイタ L1R	ハリイタ L2R	ハリイタ L3R	ハリイタ L4R
	NEEDLE PLATE, R L1	NEEDLE PLATE, R L2	NEEDLE PLATE, R L3	NEEDLE PLATE, R L4
AA1	S37754-001	S37690-001	S37692-001	S37758-001
-1-1-1-4	ヌノオサエ R-JL1	ヌノオサエ R-JL2	ヌノオサエ R-JL3	ヌノオサエ R-JL4
	WORK CLAMP, R-J L1	WORK CLAMP, R-J L2	WORK CLAMP, R-J L3	WORK CLAMP, R-J L4
AA1	S37673-101	S37674-101	S37675-101	S37676-101
-1-1-2	イドウハ L1R	イドウハ L2R	イドウハ L3R	イドウハ L4R
	MOVABLE KNIFE, R L1	MOVABLE KNIFE, R L2	MOVABLE KNIFE, R L3	MOVABLE KNIFE, R L4
AA1	S37669-101	S37670-101	S37671-101	S37672-101
-1-1-3	イドウハ L1L	イドウハ L2L	イドウハ L3L	イドウハ L4L
	MOVABLE KNIFE, L L1	MOVABLE KNIFE, L L2	MOVABLE KNIFE, L L3	MOVABLE KNIFE, L L4
AA1	S37665-000	S37666-000	S37667-000	S37668-000
-1-1-4	イトサバキ L1	イトサバキ L2	イトサバキ L3	イトサバキ L4
	THREAD HANDLER, L1	THREAD HANDLER, L2	THREAD HANDLER, L3	THREAD HANDLER, L4
AA1	S37661-101	S37662-101	S37663-101	S37664-101
-1-1-5	イドウハクドウカム L1	イドウハクドウカム L2	イドウハクドウカム L3	イドウハクドウカム L4
	MOVABLE KNIFE DRIVING CAM, L1	MOVABLE KNIFE DRIVING CAM, L2	MOVABLE KNIFE DRIVING CAM, L3	MOVABLE KNIFE DRIVING CAM, L4
AA1	S38577-201	S38579-201	S38581-201	S38583-201
-1-2	L1 プレート Lクミ	L2 プレート Lクミ	L3 プレート Lクミ	L4 プレート Lクミ
	L1 PLATE ASSY, L	L2 PLATE ASSY, L	L3 PLATE ASSY, L	L4 PLATE ASSY, L
AA1	S37731-301	S37728-301	S37735-301	S37732-301
-1-2-1	オサエプレート JL1ソククミ	オサエプレート JL2ソククミ	オサエプレート JL3ソククミ	オサエプレート JL4ソククミ
	WORK CLAMP PLATE SET, J L1	WORK CLAMP PLATE SET, J L2	WORK CLAMP PLATE SET, J L3	WORK CLAMP PLATE SET, J L4
AA1	S37643-201	S37645-201	S37647-201	S37649-101
-1-2-1-2	ハリイタ L1L	ハリイタ L2L	ハリイタ L3L	ハリイタ L4L
	NEEDLE PLATE, L L1	NEEDLE PLATE, L L2	NEEDLE PLATE, L L3	NEEDLE PLATE, L L4
AA1	S37755-001	S37689-001	S37691-001	S37759-001
-1-2-1-4	ヌノオサエ L-JL1	ヌノオサエ L-JL2	ヌノオサエ L-JL3	ヌノオサエ L-JL4
	WORK CLAMP, L-J L1	WORK CLAMP, L-J L2	WORK CLAMP, L-J L3	WORK CLAMP, L-J L4
AA1	S43337-000	S43338-000	S43339-000	S43340-000
-1-3	981 ショウハーネス L1	981 ショウハーネス L2	981 ショウハーネス L3	981 ショウハーネス L4
	HARNES, 981 L1	HARNES, 981 L2	HARNES, 981 L3	HARNES, 981 L4
AA1	S37702-001	S37704-001	S37706-001	S37708-001
-1-5	ハンマー S12	ハンマー S16	ハンマー S20	ハンマー S24
	HAMMER, S12	HAMMER, S16	HAMMER, S20	HAMMER, S24
AA1	S37704-001	S37706-001	S37708-001	S42053-001
-1-6	ハンマー S16	ハンマー S20	ハンマー S24	ハンマー S28
	HAMMER, S16	HAMMER, S20	HAMMER, S24	HAMMER, S28

Sp1. 仕様別部品一覧表 / DIFFERENT PARTS LIST

REF. NO.	L5 28-32mm	L6 32-36mm	L7 36-40mm
AA1 -1	S44272-001 クミカエブヒンセット (L5) EXCHANGE PARTS SET, L5	S44273-001 クミカエブヒンセット (L6) EXCHANGE PARTS SET, L6	S44274-001 クミカエブヒンセット (L7) EXCHANGE PARTS SET, L7
AA1 -1-1	S41470-201 L5プレート Rクミ L5 PLATE ASSY, R	S41472-201 L6プレート Rクミ L6 PLATE ASSY, R	S41474-201 L7プレート Rクミ L7 PLATE ASSY, R
AA1 -1-1-1	S40830-101 オサエプレート JR5ソウクミ WORK CLAMP PLATE SET, JR5	S41489-101 オサエプレート JR6ソウクミ WORK CLAMP PLATE SET, JR6	S41491-101 オサエプレート JR7ソウクミ WORK CLAMP PLATE SET, JR7
AA1 -1-1-1-2	S40822-001 ハリイタ L5R NEEDLE PLATE, R L5	S41479-001 ハリイタ L6R NEEDLE PLATE, R L6	S41481-001 ハリイタ L7R NEEDLE PLATE, R L7
AA1 -1-1-1-4	S41483-001 ヌノオサエ R-JL5 WORK CLAMP, R-J L5	S41485-001 ヌノオサエ R-JL6 WORK CLAMP, R-J L6	S41487-001 ヌノオサエ R-JL7 WORK CLAMP, R-J L7
AA1 -1-1-2	S37674-101 イドウハ L2R MOVABLE KNIFE, R L2	S37675-101 イドウハ L3R MOVABLE KNIFE, R L3	S37676-101 イドウハ L4R MOVABLE KNIFE, R L4
AA1 -1-1-3	S37670-101 イドウハ L2L MOVABLE KNIFE, L L2	S37671-101 イドウハ L3L MOVABLE KNIFE, L L3	S37672-101 イドウハ L4L MOVABLE KNIFE, L L4
AA1 -1-1-4	S37666-000 イトサバキ L2 THREAD HANDLER, L2	S37667-000 イトサバキ L3 THREAD HANDLER, L3	S37668-000 イトサバキ L4 THREAD HANDLER, L4
AA1 -1-1-5	S37662-101 イドウハクドウカム L2 MOVABLE KNIFE DRIVING CAM, L2	S37663-101 イドウハクドウカム L3 MOVABLE KNIFE DRIVING CAM, L3	S37664-101 イドウハクドウカム L4 MOVABLE KNIFE DRIVING CAM, L4
AA1 -1-2	S41471-101 L5プレート Lクミ L5 PLATE ASSY, L	S41473-101 L6プレート Lクミ L6 PLATE ASSY, L	S41475-101 L7プレート Lクミ L7 PLATE ASSY, L
AA1 -1-2-1	S40831-101 オサエプレート JL5ソウクミ WORK CLAMP PLATE SET, JL5	S41490-101 オサエプレート JL6ソウクミ WORK CLAMP PLATE SET, JL6	S41492-101 オサエプレート JL7ソウクミ WORK CLAMP PLATE SET, JL7
AA1 -1-2-1-2	S40823-001 ハリイタ L5L NEEDLE PLATE, L L5	S41480-001 ハリイタ L6L NEEDLE PLATE, L L6	S41482-001 ハリイタ L7L NEEDLE PLATE, L L7
AA1 -1-2-1-4	S41484-001 ヌノオサエ L-JL5 WORK CLAMP, L-J L5	S41486-001 ヌノオサエ L-JL6 WORK CLAMP, L-J L6	S41488-001 ヌノオサエ L-JL7 WORK CLAMP, L-J L7
AA1 -1-3	S43341-000 981 ショウハーネス L5 HARNES, 981 L5	S43342-000 981 ショウハーネス L6 HARNES, 981 L6	S43343-000 981 ショウハーネス L7 HARNES, 981 L7
AA1 -1-5	S37197-001 ハンマー 26 HAMMER, 26	S37199-001 ハンマー 30 HAMMER, 30	S37201-001 ハンマー 34 HAMMER, 34
AA1 -1-6	S37199-001 ハンマー 30 HAMMER, 30	S37201-001 ハンマー 34 HAMMER, 34	S35093-001 ハンマー 38 HAMMER, 38



Sp2. 仕様別部品一覧表 / DIFFERENT PARTS LIST





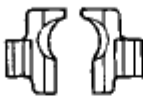

-00の場合は10~50mm

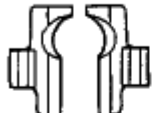
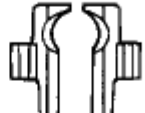
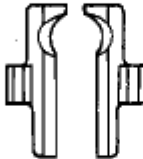
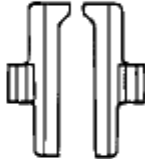
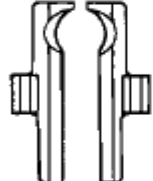
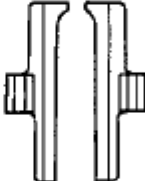
10 to 15 mm are available for -00 specification.

-01の場合は10~38mmが取付可能

10 to 38 mm are available for -01 specification.

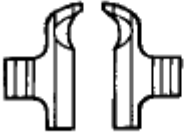
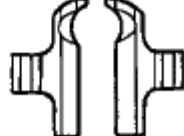
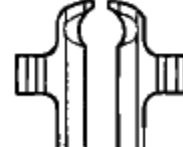
布押え / Work clamp (F2-80-1-4, 81-1-4)				
(L)	S35455-101	S39929-001	S35197-001	S39931-001
(R)	S35454-101	S39930-001	S35198-001	S39932-001
(-00 ・ -01 用)	< 10~18mm用 >	< 18~22mm用 >	< 22~26mm用 >	< 26~30mm用 >
				
	S35453-001	S35200-101	S37679-001	S37677-101
	S35452-001	S35199-101	S37680-001	S37678-101
< 26~38mm用 >	< 38mm用 >	< 50mm用 >	< 50mm用 >	
				

布押え / Work clamp (F3-80-2-4, 81-2-4)				
(L)	S37755-001	S37689-001	S37691-001	S37759-001
(R)	S37754-001	S37690-001	S37692-001	S37758-001
(-02 ・ -52 用)	L1< 14~18mm用 >	L2< 18~22mm用 >	L3< 22~26mm用 >	L4< 26~30mm用 >
				
	S41484-001	S41486-001	S41488-001	S43408-001
	S41483-001	S41485-001	S41487-001	S43409-001
	S41483-001	S41485-001	S41487-001	S43411-001
L5< 28~32mm用 >	L6< 32~36mm用 >	L7< 36~40mm用 >	L3W< 22~26mm用 >	L4W< 26~30mm用 >
				
< ウエストベルト押え用 / For waist belt presser >				

Sp3. 仕様別部品一覧表 / DIFFERENT PARTS LIST

-00の場合は38mm, 50mm共取付可能
 -01の場合は38mmのみ取付可能

Both 38 mm and 50 mm are available for -00 specification.
 Only 38 mm is available for -01 specification.

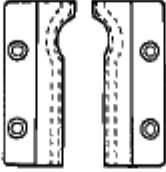
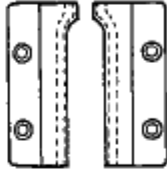
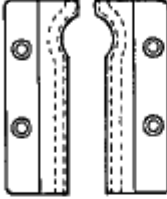
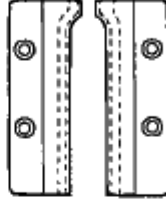
針板 / Needle plate (F2-80-1-2, 81-1-2)				
(L)	S35308-101(L)	S35307-101(SL)	S37683-101(L-50)	S37681-101(SL-50)
(R)	S35309-101(R)	S35306-101(SR)	S37684-101(R-50)	S37682-101(SR-50)
(-00 ・ -01 用)	< 38mm用 >	< 38mm用 >	< 50mm用 >	< 50mm用 >
				

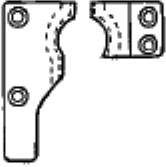
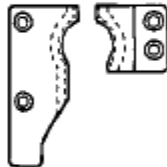
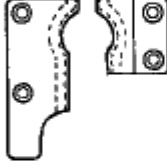
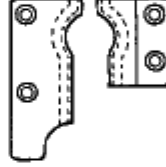
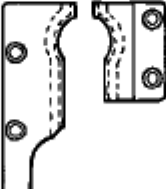
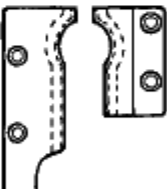
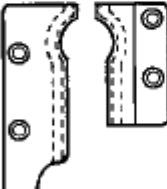
針板 / Needle plate (F3-80-2-2, 81-2-2)				
(L)	S37643-201(L1L)	S37645-201(L2L)	S37647-101(L3L)	S37649-101(L4L)
(R)	S37644-101(L1R)	S37646-101(L2R)	S37648-101(L3R)	S37650-101(L4R)
(-02 ・ -52 用)	L1 < 14~18mm用 >	L2 < 18~22mm用 >	L3 < 22~26mm用 >	L4 < 26~30mm用 >
				
	S40823-001(L5L)	S41480-001(L6L)	S41482-001(L7L)	
	S40822-001(L5R)	S41479-001(L6R)	S41481-001(L7R)	
	L5 < 28~32mm用 >	L6 < 32~36mm用 >	L7 < 36~40mm用 >	
				

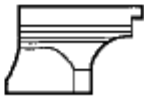
ハンマー / Hammer (H-24 Z-3-1, 3-2, 3-3)						
(-00 ・ -01 用)	ハンマーサイズ (mm)	10	12	14	16	
	部品コード	S37211-001	S37210-001	S37209-001	S37208-001	
	ハンマーサイズ (mm)	18	20	22	24	
	部品コード	S37194-001	S35092-001	S37195-001	S37196-001	
	ハンマーサイズ (mm)	26	28	30	32	
	部品コード	S37197-001	S37198-001	S37199-001	S37200-001	
(-02 ・ -52 用)	ハンマーサイズ (mm)	34	36	38	50	
	部品コード	S37201-001	S37202-001	S35093-001	S35479-001	
	ハンマーサイズ (mm)	S10	S12	S14	S16	
	部品コード	S37701-001	S37702-001	S37703-001	S37704-001	
	ハンマーサイズ (mm)	S18	S20	S22	S24	
	部品コード	S37705-001	S37706-001	S37707-001	S37708-001	
	ハンマーサイズ (mm)	S26	S28			
	部品コード	S37709-001	S42053-001			



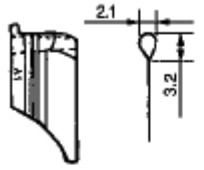
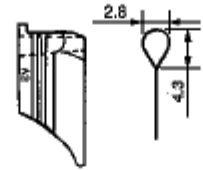
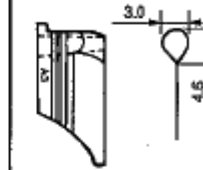
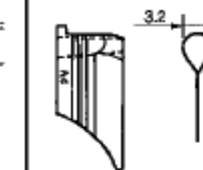
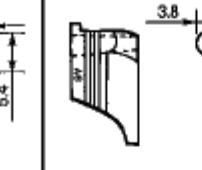
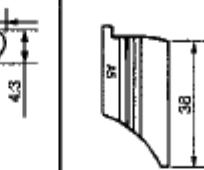
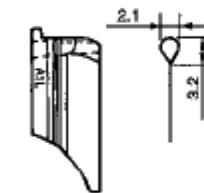
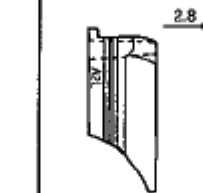
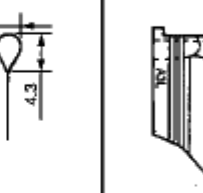
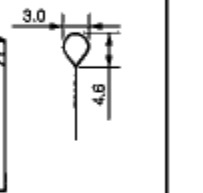
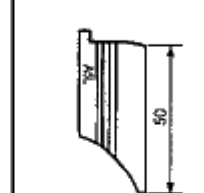



Sp4. 仕様別部品一覧表 / DIFFERENT PARTS LIST

メス / Knife (H-34-1, 34-2)					
S35439-101	S35437-101	S35480-101	S35482-101	S55247-001	S35408-101 (S)
< 38mm用 >	< 38mm用 >	< 38mm用 >	< 38mm用 >	< 38mm用 >	< 38mm用 >
					
S35438-101	S35436-101	S35481-101	S35483-101	S35409-101 (S)	
< 50mm用 >	< 50mm用 >	< 50mm用 >	< 50mm用 >	< 50mm用 >	
					

仕様ハーネス / Harness (W-43)

-00 -01 用	仕様	—			
	部品コード	S43336-000			
-02 用	仕様	L1	L2	L3	L4
	部品コード	S43337-000	S43338-000	S43339-000	S43340-000
	仕様	L5	L6	L7	
	部品コード	S43341-000	S43342-000	S43343-000	
-52 用	仕様	L1	L2	L3	L4
	部品コード	S43360-000	S43361-000	S43362-000	S43363-000
	仕様	L5	L6	L7	
	部品コード	S43364-000	S43365-000	S43366-000	

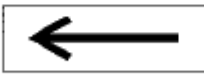
Wa. 警告ラベル / Warning labels

警告ラベル / Warning labels	品名 / Name of parts	Size(mm)	Code
	電撃ラベル・和	40 X 64	S38353-101
	Label, elec. shock 4 lang.	35 X 118	S38352-101
	操作注意ラベル・和	40 X 64	S38350-001
	Label, operation Eng.	52 X 84	S38349-001
	ワーニングマーク Mark, injury	L=16 R=0.8	S36924-001
	矢印マーク Label, arrow	10 X 30	S37058-001
	アースマーク Label, grounding	φ 12	S37060-001

索引 / INDEX

CODE	REF.NO	Page	CODE	REF.NO	Page	CODE	REF.NO	Page	CODE	REF.NO	Page
002300403	2-11	72	018061622	88	24	021060106	69	88	025040332	66	42
003300812	1-40	68	018062022	11	10	021060306	31	40		2-1-11	78
	1-42	68	018062522	27	26	021080306	3	10	025050232	1-4	12
004300513	79	4	018065022	51	88	021100202	62	88		17	28
004400603	2-3	72		56	88	021300206	62-4	2		75	88
004401003	1-35	44	018081622	2	28		9	66	025060232	103	24
008400604	1-33	50	018082036	82	4	021300302	80-1-7	16		1-8	50
012400636	33	40	018084032	23	88		81-1-7	16		13	56
012500536	86	24	018260832	1-26	44		80-2-7	18	025060236	1-74	70
014060632	56	2	018300532	96	32		81-2-7	19	025060332	20	2
	58	2	018300636	3-10	51		33	30		83	88
	68	2	018301236	16	6		11	48	025080132	83	4
	3	6		23	10		1-1-1-7	74	025080232	25	88
	9	6	018301632	23-1	6		1-2-1-7	76	025100132	63	88
	11	6		24-2	10		2-10-4	78	025350236	82-2	34
	37	6		7-2	30		11-1-1-5	84		82-1	34
	65-2	8	018400632	68	8		11-1-2-5	84	025350332	49	38
	13	10	018400832	35	2		11-1-1-5	84	025680132	77	34
	13	10		64	8		11-1-2-5	84		77	34
	1-6	12		14	12	021350106	6	36		8	48
	36	12		24	12		1-14	44	025800332	67	88
	17	22		53	26		9	48	026040136	42-3-7	62
	68	22		1-2	44	021400106	46-8	40		42-3-8	62
	90	24	018400836	1-30	68		H-8-6	52		42-3-7	64
	97	24	018401032	94	20		H-9-6	52		42-3-8	64
	9	26		1-9	44	021400202	71	4		1-13	68
	12	26		15	48		64	14	026050136	4-12-6	86
	14	26		1-2-6	76		103	20	028030242	9	36
	16	26	018401236	2	40		57	30	028030243	10	66
	19	26		1-7	68		1-40	44		14-4	66
	12	28		1-11	68		7	46		1-77	70
	14	28		1-22	68		13	46	028030246	2-12	72
	1-4	36		1-28	68		13	48	028040242	19	14
	14	36	018401622	6	22		1-9	72		71	14
	10	36		46	22		1-1-7	74		56	26
	16	48	018401636	18	12		1-1-13	74	028040246	42-3-3	62
014060832	27	30		24	22		2-1-4	78		42-3-6	62
014300832	94	32		1-20	68	021500106	4-8-3	86		42-3-3	62
014400432	6	48	018402032	21	6		4-12-1	86		42-3-6	64
014400532	45	14	018501036	33	6		4-13-1	86	028050242	43	2
	80-1-15	16	018501222	42	2	021500216	1-3	68	028050243	1-60-4	70
	81-1-15	16		26	26	021500303	35-4	6	028050246	4-8-2	86
	80-2-15	18	018501236	80-1-13	16	021660102	97	20	028060242	78	22
	81-2-15	20		81-1-13	16		1-2-9	76		52	88
	1-26	68		80-2-13	18	025030232	62-5	2		57	88
	1-1-1-15	74		81-2-13	19		7	66		70	88
	1-2-1-15	76		1-1-1-13	74	025030236	2-13	72	028060246	1-7	50
				1-2-1-13	76	025040132	8	22		12	56
014760622	50	22	018501422	1-3	12		48	22	028080242	4	28
014770622	10	22		52	22	025040232	7	14		24	88
	54	22	018501622	25-3	26		25	22	028100242	64	88
	62	22	018501631	13	22		4	36	031452206	4-13-2	86
016061031	14	10		83	24		32	66	031553202	42-2	62
	3	26	018501636	1-2	68		34	66		42-4	62
017062503	68	88	018502022	100	24	025040234	4	66	032422003	35	58
017401415	63	14	018502036	16	28		1-49	70		1-61	70
018061022	1-6	50	018503036	1-60-3	70		1-54	70	032422505	82	88
	11	56	018680822	82	24		1-76	70	032461606	78	88
018061222	77	22	021020106	1-30-6	44	025040236	H-8-5	52	047502242	30	2
018061236	60	2	021060102	22	2		H-9-5	52		51	2
018061622	2	12		9	10	025040332	51	38	048030342	15	14
	43	22									

CODE	REF.NO	Page	CODE	REF.NO	Page	CODE	REF.NO	Page	CODE	REF.NO	Page
048030342	43	14	060400516	30	30	062400812	40	26	076001800	1-4	28
	78	34		25	46		48	26		12-3	28
	78	34		1-37	68		55	26	076001850	33	12
	4	58		1-44	68		85	34	076002450	10	10
	13	58		1-1-25	74		3	36	076002800	6	28
	52	60	060400816	1-13	72		29	40	076003850	1	28
	1-18	68	080630312	1-39	44		47	40		93	32
	2-1-15	78	061300416	1-24	44		49	40	076202850	5	28
048050142	80-1-11	16	062020416	1-30-5	44		51	40	087310815	3-6	51
	81-1-11	16	062260406	1-15	44		53	40	087311015	3-7	51
	80-2-11	18	062260612	1-7	44		56	42	0A4301005	1-39-18	50
	81-2-11	19		20	46		58	42	0A4400605	42	56
	92	20		1-1-20	74		69	42	0A4400805	3-9	51
	1-1-1-11	74	062300416	28	22		6	58	0A5400806	1-5	50
	1-2-1-11	76		99	24		3	66	0A5401006	1-13	50
	1-2-4	76		25-5	26		15	66		1-14	50
048050342	1-4	14		12	38		18	66	0A5401605	H-8-4	52
	2-4	14		17	38		22	66		H-9-4	52
	4	48		1-41	44		30	66	0A5403006	1-10	50
048050346	2-15	72		18	46		31	66		1-12	50
048060342	57	22		1-1-18	74		33	66	100257010	93-3	4
	65	22	062300512	77	4		2-2	78	100887001	11	88
048080142	45	2		1-29	44		2-4	78	101118001	74	88
	48	2	062300612	13	30		2-6	78	101572101	9	86
048100142	11-5	12		44	30	062400816	37	58	102630001	1-2	14
	23-5	12	062300616	62-3	2	062401016	80-1-9	16		2-2	14
	60	88		80	4		81-1-9	16	102843004	23	10
048120142	1-5	28		31	6		80-2-9	18	104336003	1-37	44
	12-5	28	062300806	14-3	66		81-2-9	19	105073001	77	88
	1-9	68	062301016	11	14		2	48	105248003	50	38
048150142	11	10		32	30		1-1-1-9	74	105288001	37	30
	2	28		2-10-2	78		1-2-1-9	76		2-10-9	78
048160242	66	22	062301205	2-6	72	062401212	6	38	106129002	93-1-5	4
048260242	11-3	12	062301414	1-24	68		67	42		93-4	4
	23-3	12		1-36	68		42	66	107017002	39	2
048280242	93	24	062301606	8	66		2-1-12	78		88	4
	1-3	28	062350516	83-2	34	062401416	63	30	107779001	10	86
	12-4	28		83-1	34	062401616	1-75	70	107780001	12	88
048320242	7	28		1-59	70	062403512	42-3-2	62	109763002	1-3	14
048350242	17	10	062350616	4	38		42-3-5	62		2-3	14
052400606	2-16	72		37	38		42-3-2	62	112754001	52	38
052400806	73	88		48	38		42-3-5	64	113006001	14	38
060020416	80-1-1-2	16		7	40	062500804	6	2	114483002	18	88
	81-1-1-2	16		27	40		96	4	114486002	53	2
	80-2-1-2	18		41	58	062500812	54	2	115157001	17	88
	81-2-1-2	19	062351615	3	30	062501006	4-13-3	86	115947001	19	2
	1-1-1-1-2	74	062400612	37	40	062501202	4	2	116920001	21	10
	1-2-1-1-2	76		39	40		10	2		11	28
060300416	60	30		4	48		38	14	117150001	36	38
	39-1	34	062400616	8	38		40	14	117466000	19	88
	44	38		10	38		11	30	117936001	89	4
	1-47	70		15	46		18	30		2-17	72
	1-52	70		1-1-15	74	062501406	4-12-2	86	118064001	15	88
060300616	1-11	72	062400812	12	2		4-12-4	86	118837001	8	86
060350616	39-2	34		24	2	062670616	45	40	122257001	53	88
	1-1-1-17	74		27	2	062681412	7	48	128652001	1-5-3	12
	1-2-1-17	76		95	4	072620180	16	12		84-2	24
	2-10-10	78		8	14	072620260	2	10	140342001	21	88
060400416	50	66		17	14	076000800	11-2	12	140553102	18	6
	1-48	70		65	14		23-2	12	140682001	1-60-1-2	70
	1-53	70		100	20	076001800	92	24	141276001	22	10

索引 / INDEX

CODE	REF.NO	Page	CODE	REF.NO	Page	CODE	REF.NO	Page	CODE	REF.NO	Page
141514002	53	6	153787001	1-5	80	S01524000	31-1-1	58	S12150000	9-1	58
141542001	1-20	44		1-5	80	S01542000	1-60-1-4	70		50-1	60
	10	46		1-5	80	S01694001	1-22	44		1-15-3	68
	1-1-10	74		1-5	80	S02460001	19	22		2-1-13-1	78
142002001	13	88		1-5	82		71	22	S13955000	45	58
142627001	34	12		1-5	82		76	22	S16568000	1-15	50
142642001	46	26		1-5	82	S02766209	4	86	S17608009	65-1	8
142721001	14	88	154465001	52	2	S02775001	4-4	86	S17965001	61	2
142990001	4-11-3	86	154562001	68	32	S02779009	4-10	86	S18707129	17	28
143196001	39	38		42	40	S02788009	4-11	86	S18707137	18	28
	40	38		61	42	S02789009	4-11-1	86	S20681000	22	40
	45	38		2-1-6	78	S04557000	38	58	S20682102	21	40
144103009	19	40	155510001	69	32		5-4	66	S20695001	54	40
144504001	70	32		43	40		14-5	66	S20696001	55	40
	41	40		62	42		44	66		70	42
	60	42		2-1-7	78		1-72	70	S20698121	40	40
	2-1-5	78	155559001	7	10		1-12	72	S21716001	22	46
145446001	11	40	156112003	4-5	86		1-4	76		1-1-22	74
146124001	1-10	72	158437001	90	4		2-1-21	78	S21728001	17	2
146924000	6-2	40	158581000	34	58	S04897000	1-60-1-5	70	S21798001	4-8	86
146926001	6	40	158827009	14	2		1-69	70	S23612051	38	6
146927001	6-1	40	159113001	108	34	S05356000	95	20		15	36
148294001	47	6		2-9-3	78		1-33	68		9	36
148407001	115-3	34	159150000	26	88		1-2-7	76	S23616101	1-1-2	2
	2-10-3-3	78	159220101	10	40	S06696004	80-1-3	16	S23651001	4	10
148727001	19	10	159221001	20	40		81-1-3	16		6	10
148782001	101	24	159458009	18	2		80-2-3	18		8	10
149287000	5	58	159805001	18	40		81-2-3	19		7	28
149547000	26	66	200190001	81	88		1-1-1-3	74		9	28
149796001	6	86	218859001	2-1-5	54		1-2-1-3	76		11	28
150173003	4-6	86		2-2-5	54		2-12	78	S23880000	42-3-1-5	62
150174000	4-7-1	86		2-3-5	54		55	14		42-3-1-5	62
150179002	4-8-1	86		2-4-5	54	S08030000	1-39-16	50	S24325001	1-25	68
150182000	4-2	86		2-7-5	54		79	88	S27844201	53	22
150183000	4-11-2	86	224514001	2-1-4	54	S08808001	96	20		61	22
150188009	4-9	86		2-2-4	54		1-2-8	76	S29410001	4	22
150206002	4-4-1	86		2-3-4	54	S10077100	69	22	S30302000	4-12-5	86
150335001	16	88		2-4-4	54	S10078001	80	22	S31568000	79	22
150592001	1-26	50		2-7-4	54	S10079101	81	24	S31760000	1-32	50
150607000	75	4	228475000	1-37	50	S10243000	23	66	S32264001	91	4
150644009	32	40		1-38	50		28	66	S32335100	16-1	66
150756000	92	4		2-7	72	S10439001	8	36	S33899000	78	4
151998000	20	10	232384001	1-39-7	50	S10546000	6-1-1	66	S34844001	93-1-2	4
152861101	58	88	340400001	39	58	S10856001	1-3	66	S34881001	1-5	44
152862001	59	88		49	66		2-2	66		12	46
152863001	65	88	417526000	11-2	22		5-3	66		1-1-12	74
152864000	66	88	530138001	56	22	S11426000	1-5-2	68	S34883001	1-12	44
152865201	61	88		64	22	S11433000	31-1-2	58	S34884000	1-38	44
152889001	44	40	542515001	1-31	44		9-3	58	S34885001	1-34	44
152904001	1-36	44	552907000	29	66		1-32-2	68	S34886001	1-33	44
152948001	35	38	625010000	60	58	S11817000	36	58	S34887001	1-32	44
152969001	40	58		21	66	S11949000	1-25	50	S34888101	1-30-3	44
153098000	93-2	4		27	66	S12004000	18	22	S34889101	1-30	44
153219001	1-18	44	J02657001	2-1-3	54		72	22	S34890001	1-30-1	44
153242000	1-39-15	50		2-2-3	54		75	22	S34891101	1-30-2	44
	80	88		2-3-3	54	S12104000	32	58	S34892001	1-30-4	44
153274001	1-60-1-3	70		2-4-3	54		57	60	S34893001	1-28	44
153596001	26	10		2-7-3	54		2-1-20	78	S34894001	1-27	44
153675001	27	6	S00480000	1-73	70	S12150000	1-1	58	S34895001	1-25	44
153787001	28	46	S00554000	1-31	50		8-1	58	S34896001	1-23	44
	1-1-26	74	S01522000	1-68	70		10-1	58	S34897001	1-21	44

CODE	REF.NO	Page	CODE	REF.NO	Page	CODE	REF.NO	Page	CODE	REF.NO	Page
S34898001	1-19-1	44	S34996001	13	38	S35058001	1	48	S35118001	72	32
S34899001	1-19	44	S34997001	11	38	S35059001	2	48		107	34
S34900001	1-17	44	S34998001	9	38	S35060001	5	48		2-9-4	78
S34901001	1-16	44	S34999001	7	38	S35061000	7	36	S35121000	46	6
S34902001	1-13	44	S35001000	3	38	S35062001	6	36	S35122000	45	6
S34903001	1-11	44	S35002100	2	38	S35063001	1-2	36	S35123000	44	6
S34905101	1-8	44	S35003201	1	38	S35064001	1-3	36	S35124000	43	6
S34906100	1-6	44	S35007000	2	30	S35065001	2	36	S35125000	42	6
	19	46	S35010001	4	30		8	36	S35126001	40	6
	1-1-19	74	S35011001	10	30	S35066001	1	36	S35127001	39	6
S34910101	1-4	44	S35012001	12	30	S35067001	1-1	36	S35128001	36	6
S34913001	1-3	44	S35014001	21	30	S35068001	5	36	S35129001	35-3	6
S34914001	1-1	44	S35015101	14	30	S35069001	2-3	36	S35130001	35-2	6
S34915000	5	86	S35016001	17	30	S35070101	2-2	36	S35131001	35-1	6
S34916001	10-3	58	S35017001	19	30	S35071001	2-1	36	S35132101	35	6
S34917001	1-1	40	S35018001	20	30	S35072101	2	36	S35133014	34	6
S34918101	1-2	40		62	30	S35073001	1	36	S35133016	34	6
S34922101	102	20		46-6	40	S35074201	1	26	S35133018	34	6
	1-4	40	S35019001	22	30	S35075201	1-1	26	S35133114	7	86
	1-7	72	S35020001	23	30	S35076101	1-2	26	S35133116	7	86
	2-1-3	78	S35021000	24	30	S35077000	1-3	26	S35133118	7	86
S34923001	13	40	S35022101	25	30	S35078001	41	6	S35134001	32	6
S34924001	26	40	S35023001	26	30		1-4	26	S35135001	30	6
S34925101	1-2	58	S35024101	28	30		45	26	S35136001	29	6
S34928001	38	40	S35025001	31-1	34	S35079000	1-5	26	S35137001	28	6
S34934001	52	40	S35026001	38-1	34	S35080001	2	26	S35138001	26	6
S34936001	46-1	40	S35027001	34	30	S35081001	5	26	S35142001	25	6
S34937001	46-2	40	S35028000	35	30	S35082001	6	26	S35143001	24-1	10
S34938101	46-3	40	S35029001	36-1	34	S35083001	13	26		7-1	30
S34939001	48	40	S35030001	42	30	S35084001	15	26	S35144001	22	6
S34940001	46-4	40	S35032101	47	30	S35085001	8	26	S35148001	19	6
S34941001	46-5	40		52	30	S35086001	11	26	S35150001	17-1	6
S34942001	50	40	S35033001	51	30	S35087001	10	26	S35154000	5-1-1	66
S34943001	46-7	40	S35034001	50	30	S35088001	7	26	S35162101	14-2	66
S34944101	46	40	S35035101	53	30	S35089001	17	26	S35164101	2-3	66
S34948101	1	30	S35036101	54	30	S35090001	18	26	S35166001	41	14
S34950209	1	22	S35037001	56	30	S35091001	23	26	S35167001	80-1-14	16
S34956209	13	2	S35038001	58	30	S35092001	3-1	86	S35168001	81-1-14	16
S34957001	1	14	S35039000	59	30	S35092001	24	92	S35169001	16	14
S34963001	2	14	S35040000	61	30	S35093001	24	26	S35174001	51	22
S34964001	2-1	14	S35041000	64	30		1-12	82	S35176001	2	22
S34965001	1-1	14	S35042000	66	30		3-3	86	S35177001	3	22
S34966001	3	14	S35043001	65	30		1-6	90	S35178001	12	22
	1-3	40	S35044001	67	30		24	92	S35179000	15	22
	1-8	72	S35045001	71	32	S35094301	25-1	26	S35180000	11-1	22
S34967001	6	14	S35046000	73	32	S35097001	25-2	26	S35181001	11	22
S34968000	12	14	S35048101	75	34	S35098000	25-4	26	S35182001	23	22
S34969001	14	14		75	34	S35100001	47	26	S35183000	26	22
S34970001	13	14	S35049001	76	34	S35101001	51	26	S35184001	27	22
S34971001	43	38		76	34	S35102001	52	26		73	22
S34972000	42	38	S35050001	79	34	S35104001	54	26	S35185101	1-2	66
S34974000	38	38		79	34	S35106001	13	28	S35186001	55	22
S34979100	34	38	S35051001	80	34	S35107001	10	28	S35187001	96	24
S34980000	33	38		80	34	S35108001	5	28	S35188001	16	22
S34981000	32	38	S35052001	86	34	S35110001	1-2	28	S35189001	63	22
S34982000	31	38	S35053001	9	30	S35112101	1	28	S35190001	70	22
S34983000	30	38	S35054001	29-1	34	S35113001	66	8	S35191001	74	22
S34984000	29	38	S35055001	87	34	S35114001	63	8	S35192001	84	24
S34985000	28	38	S35056001	88	34	S35116001	60	8	S35193000	84-1	24
S34986000	27	38	S35057001	92	34	S35117001	59	8	S35194001	85	24
S34995000	15	38		92	34	S35118001	54	8	S35195001	91	24

索引 / INDEX

CODE	REF.NO	Page	CODE	REF.NO	Page	CODE	REF.NO	Page	CODE	REF.NO	Page
S35196100	89	24	S35237001	1-1-1-10	74	S35310001	81-2-1	19	S35371000	21	58
S35197001	81-1-4	91	S35238001	80-1-8	16		1-2-1-1	76	S35372000	22	58
S35198001	80-1-4	91		81-1-8	16	S35315001	1-1-1-1-1	74	S35374000	24	58
S35199101	80-1-4	91		80-2-8	18	S35316001	80-1-1-1	16	S35375000	25	58
S35200101	81-1-4	91		1-1-1-8	74		81-1-1-1	16	S35376000	26	58
S35201000	40	2	S35239101	35	14		80-2-1-1	18	S35377100	27	58
S35202000	81	4	S35240001	36	14		81-2-1-1	19	S35378100	28	58
S35203001	23	2	S35245001	7	10		1-2-1-1-1	76	S35382000	42-1-2	62
S35204001	76	4	S35246001	5	10	S35317001	81-1-1	16	S35386000	42-1-1	62
S35206201	69	2	S35247001	3	10	S35318001	80-1-1	16	S35389001	42-1	62
S35207001	67	2	S35249001	16	10	S35319001	80-1-1	16	S35395000	42-1-3	62
S35211009	66	2	S35250001	20	10	S35321001	53	14	S35398100	29	58
S35215001	59	2	S35251001	21	10		75	14	S35399100	30	58
S35216001	57	2	S35252001	18	10	S35322001	54	14	S35408101	34-2	93
S35217001	55	2	S35255001	17	10	S35323001	56	14	S35409101	34-1	93
S35218001	47	2	S35256001	15	10	S35324001	57	14	S35410001	45	30
S35219001	44	2	S35257000	12	10	S35326001	80-1-17	16	S35411001	46-1	30
S35220101	41	2	S35258001	10	10		81-1-20	16	S35412101	48	30
S35221001	38	2	S35259001	6	10		81-1-17	16	S35413101	49-1	30
	70	2	S35260001	5	10		80-2-17	19	S35417000	15	58
S35222001	37	2	S35262001	4	10		81-2-17	20	S35423000	42-1-4	62
S35223101	34	2	S35263101	2	10		90	32	S35424000	42-1-5	62
S35224001	26	2	S35264001	1	10		27	46	S35425001	42-1-6	62
S35225000	15	2	S35265001	12-2	28		2-8	78	S35426000	14-1	58
S35226001	11	2	S35267101	12-1-1	28	S35327001	62	14	S35428001	46-9	40
S35227009	8	2	S35268101	12-1	28	S35328001	67	14	S35429001	5	14
S35228009	9	2	S35269101	12	28	S35329001	81-1-18	16	S35430001	57-1	40
S35229000	7	2	S35270001	10	28	S35330001	80-1-18	16	S35431101	1-1	28
S35230009	5	2	S35272001	8	28	S35331101	17	6	S35435000	1-5-1	12
S35231000	3	2	S35273001	4	28	S35332001	15	6	S35436101	34-1	26
S35232009	2	2	S35274001	6	28		22	10		34-1	93
S35233201	81-1-12	16	S35275100	3	28	S35333001	14	6	S35437101	34-2	26
	81-2-12	19	S35276101	1-1	12	S35334001	13	6		34-2	93
	1-2-1-12	76	S35282000	1-5-2	12	S35335001	12	6	S35438101	34-1	93
S35234201	80-1-12	16	S35283001	1-5	12	S35337101	8	6	S35439101	34-2	93
	80-2-12	18	S35284101	11-1	12	S35338001	10	6	S35452001	80-1-4	16
	1-1-1-12	74		23-1	12	S35339101	2	6		80-1-4	91
S35235001	80-1-6	16	S35287001	23-4	12	S35340001	7	6	S35453001	81-1-4	16
	81-1-6	16	S35288101	23	12	S35346101	1	6		81-1-4	91
	80-2-6	18	S35290001	11-4	12	S35347000	80-1-16	16	S35454101	80-1-4	91
	81-2-6	19	S35291101	11	12		80-2-16	19	S35455101	81-1-4	91
	10	48	S35296001	15	12	S35347100	1-1-1-16	74	S35456001	72	14
	1-1-1-6	74	S35297000	17	12	S35348000	81-1-16	16	S35457001	73	14
	1-2-1-6	76	S35298001	5-2	66		81-2-16	20	S35458001	74	14
	11-1-1-3	84	S35299000	32	12	S35348100	1-2-1-16	76	S35460000	44	58
	11-1-2-3	84	S35300000	31	12	S35349101	1	58	S35466001	30	40
	11-1-1-3	84	S35302001	35	12	S35350000	7	58	S35471001	46-2	34
	11-1-2-3	84	S35303201	39	14	S35351001	1-3	58	S35472101	49-2	34
S35236000	80-1-5	16	S35304001	44	14		10-2	58	S35473301	25	26
	81-1-5	16	S35305001	42	14		50-2	60	S35474401	80-1	16
	80-2-5	18		3	58		2-1-13-2	78	S35475401	81-1	16
	81-2-5	19		12	58	S35360000	14	58	S35476401	81-1	16
	1-1-1-5	74		51	60	S35361001	7	48	S35478401	80-1	16
	1-2-1-5	76		2-1-14	78	S35362001	8	48	S35479001	24	92
	11-1-1-4	84	S35306101	80-1-2	92	S35364001	12	48	S35480101	34-2	93
	11-1-2-4	84	S35307101	81-1-2	92	S35365101	81	34	S35481101	34-1	93
	11-1-1-4	84	S35308101	81-1-2	16	S35366001	84	34	S35482101	34-2	93
	11-1-2-4	84	S35308101	81-1-2	92	S35367000	17	58	S35483101	34-1	93
S35237001	80-1-10	16	S35309101	80-1-2	16	S35368000	18	58	S35909000	16	58
	81-1-10	16		80-1-2	92	S35369000	19	58	S35911101	35-5	6
	80-2-10	18	S35310001	81-1-1	16	S35370000	20	58	S35912001	59	42

CODE	REF.NO	Page	CODE	REF.NO	Page	CODE	REF.NO	Page	CODE	REF.NO	Page
S36070001	93-1-4	4	S37646101	1-6	80	S37667000	1-3	82	S37690001	1-8	80
S36071001	93-1-3	4		1-1-1-2	89		1-1-4	89		1-1-1-4	89
S36260000	2-5-2	72		80-2-2	92		1-1-4	90		80-2-4	91
S36261000	1-23-1	68	S37647101	81-2-2	19	S37668000	4	46	S37691001	81-2-4	19
	1-35-1	68		1-7	80		1-3	80		1-9	80
S36345000	58	14		81-2-2	92		1-3	82		1-2-1-4	89
S36651009	17	66		1-2-1-2	89		1-1-4	89		81-2-4	91
S36659001	95	32	S37648101	80-2-2	18		1-1-4	90	S37692001	80-2-4	18
S36660101	43	30		1-6	80	S37669101	3	46		1-8	80
S37057001	45	66		1-1-1-2	89		1-2	80		1-1-1-4	89
S37059001	1-35	50		80-2-2	92		1-1-3	89		80-2-4	91
S37060001	1-36	50	S37649101	81-2-2	19	S37670101	3	46	S37693001	75	20
S37084001	93	4		1-7	80		1-2	80		2-11	78
S37085001	93-1	4		1-2-1-2	89		1-2	82	S37694001	81-2-14	20
S37086001	93-1-1	4		81-2-2	92		1-1-3	89		1-2-1-14	76
S37173000	46	38	S37650101	80-2-2	18		1-1-3	90	S37695001	80-2-14	18
S37194001	24	92		1-6	80	S37671101	3	46		1-1-1-14	74
S37195001	24	92		1-1-1-2	89		1-2	80	S37696101	29-2	34
S37196001	24	92		80-2-2	92		1-2	82		2-9-1	78
S37197001	24	26	S37652001	16	46		1-1-3	89	S37697001	57-2	42
	1-11	82		1-1-16	74		1-1-3	90		2-5	78
	3-2	86	S37653001	17	46	S37672101	3	46	S37698000	26-1	46
	1-5	90		1-1-17	74		1-2	80	S37699000	26-2	46
	24	92	S37654000	8	46		1-2	82	S37701001	24	92
S37198001	24	92		1-1-8	74		1-1-3	89	S37702001	24	26
S37199001	24	26	S37655101	9	46		1-1-3	90		1-11	80
	1-12	82		1-1-9	74	S37673101	2	46		1-5	89
	1-11	82	S37656001	11	46		1-1	80		24	92
	3-3	86		1-1-11-1	74		1-1-2	89	S37703001	24	92
	1-5	90	S37659001	21	46	S37674101	2	46	S37704001	24	26
	1-6	90		1-1-21	74		1-1	80		1-12	80
	24	92	S37660101	6	46		1-1	82		1-11	80
S37200001	24	92		1-1-6	74		1-1-2	89		3-3	86
S37201001	24	26	S37661101	5	46		1-1-2	90		1-5	89
	1-12	82		1-4	80	S37675101	2	46		1-6	89
	1-11	82		1-1-5	89		1-1	80		24	92
	3-3	86	S37662101	5	46		1-1	82	S37705001	24	92
	1-5	90		1-4	80		1-1-2	89	S37706001	24	26
	1-6	90		1-4	82		1-1-2	90		1-12	80
	24	92		1-1-5	89	S37676101	2	46		1-11	80
S37202001	24	92		1-1-5	90		1-1	80		3-3	86
S37208001	24	92	S37663101	5	46		1-1	82		1-5	89
S37209001	24	92		1-4	80		1-1-2	89		1-6	89
S37210001	24	92		1-4	82		1-1-2	90		24	92
S37211001	24	92		1-1-5	89	S37677101	81-1-4	91	S37707001	24	92
S37432001	23	6		1-1-5	90	S37678101	80-1-4	91	S37708001	24	26
	24	10	S37664101	5	46	S37679001	81-1-4	16		1-12	80
	7	30		1-4	80		81-1-4	91		1-11	80
S37643201	81-2-2	19		1-4	82	S37680001	80-1-4	16		3-3	86
	1-7	80		1-1-5	89		80-1-4	91		1-5	89
	1-2-1-2	89		1-1-5	90	S37681101	81-1-2	92		1-6	89
	81-2-2	92	S37665000	4	46	S37682101	80-1-2	92		24	92
S37644101	80-2-2	18		1-3	80	S37683101	81-1-2	16	S37709001	24	92
	1-6	80		1-1-4	89		81-1-2	92	S37711001	81-2-10	19
	1-1-1-2	89	S37666000	4	46	S37684101	80-1-2	16		1-2-1-10	76
	80-2-2	92		1-3	80		80-1-2	92	S37712001	81-2-8	19
S37645101	81-2-2	19		1-3	82	S37689001	81-2-4	19		1-2-1-8	76
	1-7	80		1-1-4	89		1-9	80	S37713001	91	20
	1-2-1-2	89		1-1-4	90		1-2-1-4	89		1-2-3	76
	81-2-2	92	S37667000	4	46		81-2-4	91	S37714001	90	20
S37646101	80-2-2	18		1-3	80	S37690001	80-2-4	18		1-2-2	76

索引 / INDEX

CODE	REF.NO	Page	CODE	REF.NO	Page	CODE	REF.NO	Page	CODE	REF.NO	Page
S37717101	101	20	S37758001	1-8	80	S38578401	1-1	89	S41452000	1-58	70
	2-1-2	78		1-1-1-4	89	S38579201	1-2	89	S41470201	1-1	90
S37718000	93	20		80-2-4	91	S38580401	1-1	89	S41471101	1-2	90
	1-2-5	76	S37759001	81-2-4	19	S38581201	1-2	89	S41472201	1-1	90
S37720001	115-2	34		1-9	80	S38582401	1-1	89	S41473101	1-2	90
	2-10-3-1	78		1-2-1-4	89	S38583201	1-2	89	S41474201	1-1	90
S37721001	115-1	34		81-2-4	91	S38584001	2	78	S41475101	1-2	90
	2-10-3-2	78	S37820001	14	46	S38585001	2-1	78	S41479001	80-2-2	18
S37723001	36-2	34		1-1-14-1	74	S38648001	4-4-2	86		1-6	82
	2-10-8	78	S37858000	1-10	44	S39108001	2-10	78		1-1-1-2	90
S37724001	103	34		23	46	S39109101	2-9	78		80-2-2	92
	2-10-5	78		1-1-23	74	S39115100	1-60-1-1	70	S41480001	81-2-2	19
S37725001	104-1	34	S37863000	55	60	S39116100	1-60-1-6	70		1-7	82
	2-10-6	78		2-1-18	78	S39910001	1-4	72		1-2-1-2	90
S37726001	31-2	34	S37864000	56	60	S39911001	1-5	72		81-2-2	92
	2-10-1	78		2-1-19	78	S39912001	1-6	72	S41481001	80-2-2	18
S37727401	80-2	18	S37866000	50-3	60	S39913001	1-1	72		1-6	82
	1-1-1	89		2-1-13-3	78	S39914001	1-2	72		1-1-1-2	90
S37728301	81-2	19	S37870000	104	20	S39929001	81-1-4	91		80-2-2	92
	1-2-1	89	S37874101	1	40	S39930001	80-1-4	91	S41482001	81-2-2	19
S37729101	80-2-1	18	S38029000	2-5	72	S39931001	81-1-4	91		1-7	82
	1-1-1-1	74	S38030000	2-5-1	72	S39932001	80-1-4	91		1-2-1-2	90
S37730001	81-2-1	19	S38041000	76	88	S40616001	40-1-1	56		81-2-2	92
	1-2-1-1	76	S38059000	2-20	72		41	56	S41483001	80-2-4	18
S37731301	81-2	19	S38060000	2-19	72	S40621000	46	66		1-8	82
	1-2-1	89	S38080001	5	48	S40622000	47	66		1-1-1-4	90
S37732301	81-2	19	S38094100	1-9	50	S40623000	H-8-3	52		80-2-4	91
	1-2-1	89	S38107100	1-18	50		H-9-3	52	S41484001	81-2-4	19
S37733401	80-2	18	S38108000	1-19	50	S40624000	40-2-1	56		1-9	82
	1-1-1	89	S38109100	1-20	50	S40628000	42-1-1-1	62		1-2-1-4	90
S37735301	81-2	19	S38110000	1-21	50	S40629000	42-1-1-2	62		81-2-4	91
	1-2-1	89	S38112001	2-1	54	S40630000	42-1-1-3	62	S41485001	80-2-4	18
S37737001	50	60	S38113000	2-1-1	54	S40635001	40	56		1-8	82
	2-1-13	78		2-4-1	54	S40640001	4-7	86		1-1-1-4	90
S37738000	53	60	S38114000	2-2	54	S40641001	4-12	86		80-2-4	91
	2-1-16	78	S38115000	2-2-1	54	S40644001	4-13	86	S41486001	81-2-4	19
S37739000	54	60		2-3-1	54	S40676000	59	58		1-9	82
	2-1-17	78		2-7-1	54	S40677000	58	58		1-2-1-4	90
S37744001	99	20	S38117000	2-3	54	S40822001	80-2-2	18		81-2-4	91
	2-1-1	78	S38118000	2-2-2	54		1-6	82	S41487001	80-2-4	18
S37749001	64	42	S38123000	10-1	54		1-1-1-2	90		1-8	82
	2-1-9	78	S38126000	10-2-2	54		80-2-2	92		1-1-1-4	90
S37750001	68	42		10-3-2	54	S40823001	81-2-2	19		80-2-4	91
	2-3	78	S38133000	2-1-2	54		1-7	82	S41488001	81-2-4	19
S37752001	89-1	34		2-3-2	54		1-2-1-2	90		1-9	82
	2-7	78	S38155000	1-41-3	51		81-2-2	92		1-2-1-4	90
S37753001	98	20	S38166000	2-1	72	S40826001	80-2-14	18		81-2-4	91
	1-2-10	76	S38170001	2-4	72		1-1-1-14	74	S41489101	80-2	18
S37754001	80-2-4	18	S38174000	2-8	72	S40827001	81-2-14	20		1-1-1	90
	1-8	80	S38175001	2-9	72		1-2-1-14	76	S41490101	81-2	19
	1-1-1-4	89	S38176101	2-10	72	S40828001	80-2-1	18		1-2-1	90
	80-2-4	91	S38177001	2-14	72		1-1-1-1	74	S41491101	80-2	18
S37755001	81-2-4	19	S38180000	2-18	72	S40830101	80-2	18		1-1-1	90
	1-9	80	S38203000	1-39-5	50		1-1-1	90	S41492101	81-2	19
	1-2-1-4	89	S38205000	1-39-9	50	S40831101	81-2	19		1-2-1	90
	81-2-4	91	S38208000	1-39-14	50		1-2-1	90	S42053001	1-12	80
S37756401	80-2	18	S38335000	81-1-19	16	S41251001	69	8		3-3	86
	1-1-1	89	S38352101	20	51	S41252000	106	34		1-6	89
S37757401	80-2	18	S38353101	21	51		2-9-2	78		24	92
	1-1-1	89	S38576401	1-1	89	S41310001	52	6	S42111101	1-1	68
S37758001	80-2-4	18	S38577201	1-2	89	S41451001	1-57	70	S42112100	1-4	68

CODE	REF.NO	Page	CODE	REF.NO	Page	CODE	REF.NO	Page	CODE	REF.NO	Page
S42113000	1-5	68	S43285000	1-2	12	S43369000	10-2	54	S44221000	42-3-1	62
S42114000	1-5-1	68	S43300009	1-1	50	S43370000	10-3	54	S44222000	42-3-1-1	62
	1-32-1	68	S43304000	1-22	50	S43375000	58	26	S44223000	42-3-1-3	62
S42115101	1-6	68	S43306000	1-23	50	S43376001	18	28		42-3-1-3	62
S42116000	1-8	68	S43308000	1-28	50	S43408001	11-1-1-1	84	S44224000	42-3-1-4	62
S42117101	1-10	68	S43309000	1-34	50		81-2-4	91		42-3-1-4	62
S42118001	1-12	68	S43318000	1-30	50	S43409001	11-1-2-1	84	S44225000	42-3-1-6	62
S42119001	1-14	68	S43320001	1	66		80-2-4	91		42-3-1-6	62
S42120100	1-15	68	S43321000	1-1	66	S43410001	11-1-1-1	84	S44226000	42-3-1-7	62
S42121000	1-15-1	68	S43322000	1-1-1	66		81-2-4	91		42-3-1-7	62
S42122000	1-15-2	68	S43323001	2	66	S43411001	11-1-2-1	84	S44228000	42-3-4-2	62
S42123001	1-16	68	S43324000	2-1	66		80-2-4	91		42-3-4-2	62
S42124001	1-17	68	S43325001	5	66	S43450001	11-1-1-2	84	S44229000	42-3-4-3	62
S42125100	1-19	68	S43326000	5-1	66		11-1-1-2	84		42-3-4-3	62
S42126101	1-21	68	S43328000	6	66	S43451001	11-1-2-2	84	S44230000	42-3-4-6	62
S42127000	1-23	68	S43329000	6-1	66		11-1-2-2	84		42-3-4-6	62
S42128101	1-27	68	S43334000	16	66	S43683001	42-3-1-2	62	S44231000	42-3-1-1	62
S42129101	1-29	68	S43335000	16-2	66		42-3-1-2	62	S44238001	1	89
S42132001	1-31	68	S43336000	43	93	S43701001	11-1	84	S44239001	1	89
S42133000	1-32	68	S43337000	1-10	80	S43702001	11-1-1	84	S44240001	1	89
S42134101	1-34	68		1-3	89	S43703001	11-1-2	84	S44271001	1	89
S42136000	1-35	68		43	93	S43704001	11-1	84	S44272001	1	90
S42137001	1-38	68	S43338000	1-10	80	S43705001	11-1-1	84	S44273001	1	90
S42138101	1-39	68		1-3	89	S43706001	11-1-2	84	S44274001	1	90
S42139101	1-41	68		43	93	S43707001	1	48	S44275001	1	80
S42140100	1-43	68	S43339000	1-10	80	S43708009	12	10	S44276001	1	80
S42141100	1-45	68		1-3	89	S43710001	1	10	S44277001	1	80
S42142100	1-50	70		43	93	S43711000	18	10	S44278001	1	80
S42143100	1-46	70	S43340000	1-10	80	S43713001	72	88	S44279101	1	68
	1-51	70		1-3	89	S43714000	71	88	S44281101	1	68
S42144101	1-55	70		43	93	S43715001	54	88	S44283001	1	82
S42145001	1-56	70	S43341000	1-10	82	S43716001	55	88	S44284001	1	82
S42146201	1-60	70		1-3	90	S43717201	9	22	S44285001	1	82
S42147201	1-60-1	70		43	93	S43718001	49	22	S44287000	51	66
S42148101	1-60-2	70	S43342000	1-10	82	S43719001	42	22	S44530000	8	58
S42149000	1-62	70		1-3	90	S43720001	67	22	S44531000	31	58
S42150100	1-63	70		43	93	S43723001	36	40	S44532000	31-1	58
S42151100	1-64	70	S43343000	1-10	82	S43724001	5	38	S44758000	H-1-2	51
S42152100	1-65	70		1-3	90	S43729000	50	88		H-2-2	51
S42153000	1-66	70		43	93	S43731001	10	58		H-3-2	51
S42154000	1-67	70	S43344000	42-7	62	S43747001	6	48		H-4-2	51
S42157000	1-70	70	S43345001	1-3	72	S43749001	87	24		H-5-2	52
S42158000	1-71	70	S43346001	1	72	S43769000	42-5	62		H-6-2	52
S42260000	1-17	50	S43347000	150	24	S43770000	42-6	62		H-7-2	52
S42838101	2	72	S43348000	151	24	S43772000	9	58		H-8-2	52
S42867001	2-2	72	S43349100	50	12	S43809001	1-41	68		H-9-2	52
S43171009	1-2	50	S43350000	1-16	50	S43880000	47	38	S45035000	2-5	56
S43175000	1-39-11	50	S43355000	1-11	50	S44204000	62-2	2	S45036000	2-6	56
S43176000	1-39-12	50	S43356001	1-4	50	S44213001	42-3	62	S45261000	1-42	51
S43177000	1-39-1	50	S43357000	9-2	58	S44214000	42-3-1	62	S45264001	14	66
S43181000	1-39-13	50	S43358000	52	66	S44215000	42-3-4	62	S45265000	14-1	66
S43184000	1-39-2	50	S43359000	1-78	70		42-3-4	62	S45266000	14-1-1	66
S43187000	1-39-20	50	S43360000	43	93	S44216000	42-3-4-1	62	S45269001	39	26
S43189000	1-39-19	50	S43361000	43	93		42-3-4-1	62	S46477000	61-1	64
S43192200	5	22	S43362000	43	93	S44217000	42-3-4-4	62	S46478000	61-2	64
S43193200	5-1	22	S43363000	43	93		42-3-4-4	62	S46479000	61-3	64
	45-1	22	S43364000	43	93	S44218000	42-3-4-5	62	S46480000	61-2-1	64
S43194200	45	22	S43365000	43	93		42-3-4-5	62	S46496009	62	2
S43201000	10-4	56	S43366000	43	93	S44219001	42-3-9	62	S46497009	62-1	2
S43274000	1-27	50	S43367000	10-2-1	54		42-3-9	64	S47033001	89-2	34
S43275000	1-29	50	S43368000	10-3-1	54	S44220001	42-3	62	S47034001	89-3	34

索引 / INDEX

CODE	REF.NO	Page	CODE	REF.NO	Page	CODE	REF.NO	Page	CODE	REF.NO	Page
S47512001	115	34	S59716001	H-6	52						
	2-10-3	78	S59717001	H-7	52						
S47592000	2-4	54	S59718001	H-8	52						
S47594000	2-7	54	S59719001	H-9	52						
S47595000	2-4-2	54	S59721001	H-1-1	51						
	2-7-2	54	S59722001	H-2-1	51						
S47668000	1-39-4	50	S59723001	H-3-1	51						
S47932001	105	34	S59724001	H-4-1	51						
	2-10-7	78	S59725001	H-5-1	52						
S48328000	42-1-1-4	62	S59726001	H-6-1	52						
S48580000	1-39-17	50	S59727001	H-7-1	52						
S48674001	3	48	S59728001	H-8-1	52						
S49071000	1-39-8	50	S59729001	H-9-1	52						
S49078001	46-3	34	S59730001	3	51						
S49079001	49-3	34		H-1-3	51						
S49471000	1-41-4	51		H-2-3	51						
S49472000	1-39-21	50		H-3-3	51						
S49484000	1-41-2	51		H-4-3	51						
S49485000	1-41-1	51		H-5-3	52						
S49495000	3-3	51		H-6-3	52						
S49496001	3-4	51		H-7-3	52						
S49586000	1-39-3	50		H-8-7	52						
S49939101	1-39	50		H-9-7	52						
S51194001	67	8	S59740000	3-13	51						
S51195001	20	6	S59931001	4-12-3	86						
S51215001	1-1-1	2	SA0029001	16	30						
S51219001	63	42	SA0030001	15	30						
	2-1-8	78	SA0037000	1-39-6	50						
S51220001	65	42	SA1034000	1-39-10	50						
	2-1-10	78	U32744000	1-41-5	51						
S51282001	4-3	86	U85274000	1-44-1	51						
S51283001	4-1	86	UA4897000	1-43-1	51						
S52245000	35	56	XA2220050	3-8	51						
S52821001	14-1	30									
S52824001	14-3	30									
S52832000	14-2	30									
S52978000	3-1-3	51									
S52979000	3-2	51									
S53010101	3-5	51									
S53884001	1-41	51									
S55247001	34-2	93									
S55473000	43	56									
S55663001	20	88									
S56025001	24	46									
	1-1-24	74									
S58975000	3-1-1	51									
S58976000	3-12	51									
S58995000	1-24	50									
S58997001	3-1	51									
S58998000	3-1-2	51									
S59000001	1-3	50									
S59701001	1	50									
S59702000	1-43	51									
S59703000	1-44	51									
S59704000	3-11	51									
S59708001	1-40	51									
S59711001	H-1	51									
S59712001	H-2	51									
S59713001	H-3	51									
S59714001	H-4	51									
S59715001	H-5	52									

brother®

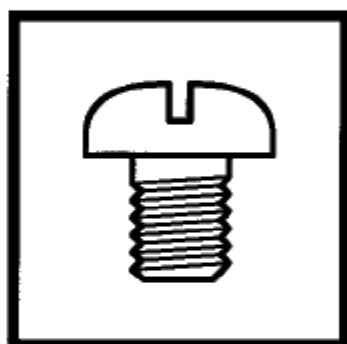

パーツブック
PARTS BOOK

ブラザー工業株式会社

〒467-8561 名古屋市瑞穂区苗代町 15 番 1 号 TEL (052) 824-2392

BROTHER INDUSTRIES, LTD

15-1, Naeshiro-cho, Mizuho-ku, Nagoya 467-8561, Japan. Phone : 81-52-824-2177

Printed in Japan

118-981
SA0281-001
2002.08.F (1)