

brother

LS5-P62 LT5-P64

一本針縫ポスト型パルスモーター式上車運送り大釜自動糸切りミシン
二本針縫ポスト型パルスモーター式上車運送り大釜自動糸切りミシン

SINGLE-NEEDLE POST BED MOTOR DRIVEN ROLLER FOOT, DROP FEED LOCK STITCHER WITH
LARGE HOOK AND THREAD TRIMMER

TWIN-NEEDLE POST BED MOTOR DRIVEN ROLLER FOOT, DROP FEED LOCK STITCHER WITH
LARGE HOOK AND THREAD TRIMMER

EINNADEL-DOPPELSTIEPSTICH-SÄULENMASCHINE MIT HÜPFERTRANSPORT UND
ANGETRIEBENEM ROLLENFUSS, GROSSEM GREIFER UND FADENABSCHNEIDER
ZWEINADEL-DOPPELSTIEPSTICH-SÄULENMASCHINE MIT HÜPFERTRANSPORT UND
ANGETRIEBENEM ROLLENFUSS, GROSSEM GREIFER UND FADENABSCHNEIDER

AIGUILLE, PILIER, POINT NOUE, PIED A ROULETTE ENTRAINE PAR MOTEUR, ENTRAINEMENT
PAR GRIFFE, AVEC CROCHET GRANDE CAPACITE ET COUPE-FIL
AIGUILLES, PILIER, POINT NOUE, PIED A ROULETTE ENTRAINE PAR MOTEUR, ENTRAINEMENT
PAR GRIFFE, AVEC CROCHET GRANDE CAPACITE ET COUPE-FIL

MAQUINA DE COLUMNA, UNA AGUJA, GARFIO GRANDE Y CORTAHILOS
MAQUINA DE COLUMNA, DOS AGUJAS, GARFIO GRANDE Y CORTAHILOS

パーツブック

PARTS BOOK

TEILEKATALOG

LIVRE DES PIECES

LIBRO DE REFERENCIA DE PIEZAS

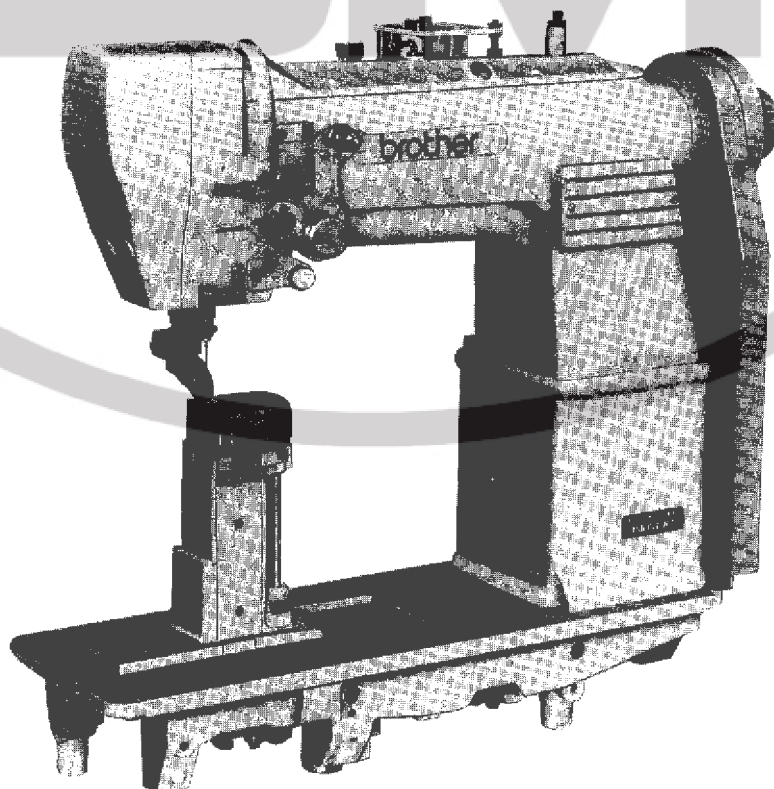

PS62001

< 1 本針 /SINGLE-NEEDLE>

LS5-P62-□□L

- 3 薄物用 /Thin materials
- 5 中厚物 /Medium-thick materials

- 3 糸切り+タッチバック /Thread Trimmer + Quick back
- 7 糸切り+タッチバック+エアー押エ上げ

Thread Trimmer + Quick back + Presser Foot Lifter (Air Type)

< 2 本針 /TWIN-NEEDLE>

LT5-P64-□□L

- 3 薄物用 /Thin materials
- 5 中厚物 /Medium-thick materials

- 3 糸切り+タッチバック /Thread Trimmer + Quick back
- 7 糸切り+タッチバック+エアー押エ上げ

Thread Trimmer + Quick back + Presser Foot Lifter (Air Type)

パーツブックご利用に際して

1. この本は、この本の表紙（正誤表の挿入されている場合は正誤表）に記載されているものと同じプレートが取り付けられているミシンのためのものです。
2. 組単位で補給する部品は、 破線で示しております。
3. この本は1992年1月のデータにもとづいて作成されたものです。
4. 部品は予告なしに設計変更される場合があります。

目 次

A. 主体関係	2
B. 上軸天ピン関係	4
C. 針棒関係	6
D. 押エ関係	8
E. 押エ上ゲ関係 (-700)	12
F. 送り関係	14
G. 送り軸関係	16
H. 下軸関係	18
J 1. カマ関係 (P62)	20
J 2. カマ関係 (P64)	22
K. タッチバック関係	24
L 1. 糸調子関係	26
L 2. 糸調子関係	26
L 3. 糸調子関係	28
M 1. 糸切り関係	30
M 2. 糸切り関係	32
N. 糸切り・タッチバック関係	34
P. ベルトカバー関係 (オプション)	36
Z 1. 付属品関係 (-700)	36
Z 2. 付属品関係	38
Z 3. 付属品関係	40
索引	41~47

Notes for using this parts book

1. This book is applicable to sewing machine which have the same plate number as shown on the cover of this book (or correction sheet).
2. Parts supplied as complete assemblies are circled by a dotted line  .
3. This book was prepared based on information available in January 1992.
4. Parts are subject to changes in design without prior notice.

CONTENTS

A. Machine body	2
B. Upper shaft and thread take-up mechanism	4
C. Needle bar mechanism	6
D. Presser foot mechanism	8
E. Work clamp lifter mechanism (-700)	12
F. Feed mechanism	14
G. Feed shaft mechanism	16
H. Lower shaft mechanism	18
J1. Rotary hook mechanism (P62)	20
J2. Rotary hook mechanism (P64)	22
K. Quick back mechanism	24
L1. Thread tension	26
L2. Thread tension	26
L3. Thread tension	28
M1. Thread trimmer mechanism	30
M2. Thread trimmer mechanism	32
N. Thread trimmer and quick back mechanism	34
P. Belt cover mechanism (Option parts)	36
Z1. Accessories (-700)	36
Z2. Accessories	38
Z3. Accessories	40
INDEX	41 ~ 47

Hinweise Zur Verwendung dieser Teilleiste

1. Dieses Buch bezieht sich auf die Nähmaschinen mit derselben Kennungsnummer wie auf diesem Buchumschlag (oder auf dem Korrekturblatt).
2. Die Teile, die als kompletter Satz geliefert werden, sind mit einer gestrichelten Linie umrandet.
3. Dieses Buch basiert auf den Information vom Januar 1992.
4. Modelländerungen sind vorbehalten.

INHALTSVERZEICHNIS

A. Maschinengehäuse	2
B. Obere Welle und Fodenabnahmevorrichtung	4
C. Nadelstangenvorrichtung	6
D. Stoffdrückerfuß	8
E. Stoffhalterhebevorrichtung (-700)	12
F. Transportvorrichtung	14
G. Transport welle	16
H. Untere Welle	18
J1. Greifervorrichtung (P62)	20
J2. Greifervorrichtung (P64)	22
K. Schnellumkehrvorrichtung	24
L1. Faderspannung	26
L2. Faderspannung	26
L3. Faderspannung	28
M1. Fadenabschneidevorrichtung	30
M2. Fadenabschneidevorrichtung	32
N. Fadenabschneider und Schnellumkehrvorrichtung	34
P. Gurtabdeckung (Sonderzubehör)	36
Z1. Zubehör (-700)	36
Z2. Zubehör	38
Z3. Zubehör	40
VERZEICHNIS	41 ~ 47

Notes sur l'utilisation de ce manuel de pièces détachées



1. Ce manuel est destiné aux machines à coudre ayant le même numéro de plaque montré sur la couverture de ce manuel (ou sur la feuille de corrections).
2. Les pièces fournies en tant qu'assemblages complets sont encadrées avec un trait pointillé  .
3. Ce manuel a été fait d'après les renseignements valables au mois de Janvier 1992.
4. Les pièces peuvent être sujettes à des modifications sans préavis.

TABLE DES MATIERES

A.	Corps de la machine	2
B.	Mécanisme de l'arbre supérieur et releveur de fil	4
C.	Mécanisme de la barre à aiguille	6
D.	Mécanisme du pied presseur	8
E.	Mécanisme de leveur du pinceur (-700)	12
F.	Mécanisme de l'entraînement	14
G.	Mécanisme de l'arbre entraînement	16
H.	Mécanisme de l'arbre inférieur	18
J1.	Mécanisme du crochet rotatif (P62)	20
J2.	Mécanisme du crochet rotatif (P64)	22
K.	Dispositif de retour arrière rapide	24
L1.	Tension du fil	26
L2.	Tension du fil	26
L3.	Tension du fil	28
M1.	Mécanisme de coupe-fil	30
M2.	Mécanisme de coupe-fil	32
N.	Mécanisme de coupe-fil et retour arrière rapide	34
P.	Couvre-courroie (Pièces en option)	36
Z1.	Accessoires (-700)	36
Z2.	Accessoires	38
Z3.	Accessoires	40
INDEX	41 ~ 47

Notas para usar este Manual de Piezas

1. Este libro sirve para todas las máquinas de coser que llevan la misma placa de identificación que la que se puede ver en la tapa de este libro (o en la boja de erratas).
2. Las piezas suministradas como conjuntos completos se enmarcan con una línea punteada .
3. Este libro ha sido compilado basándose en los datos de que se disponía en enero 1992.
4. Las piezas quedan sujetas a cambios de diseño sin aviso previo.

INDICE

A.	Cuerpo de la máquina	2
B.	Mecanismo del árbol superior y tirahilos	4
C.	Mecanismo de la barra de aguja	6
D.	Mecanismo del prensa telas	8
E.	Mecanismo del levantador de ménsula de trabajo (-700)	12
F.	Mecanismo de la alimentación	14
G.	Mecanismo de la eje alimentación	16
H.	Mecanismo del eje inferior	18
J1.	Mecanismo del cangrejo (P62)	20
J2.	Mecanismo del cangrejo (P64)	22
K.	Mecanismo de retroceso rápido	24
L1.	Tensión del hilo	26
L2.	Tensión del hilo	26
L3.	Tensión del hilo	28
M1.	Mecanismo de la cortadura de hilos	30
M2.	Mecanismo de la cortadura de hilos	32
N.	Mecanismo de la cortadura de hilos y retroceso rápido	34
P.	Cubierta de correa (Piezas opcionales)	36
Z1.	Accesorios (-700)	36
Z2.	Accesorios	38
Z3.	Accesorios	40
INDICE	41 ~ 47

A. 主体関係 / Machine body / Maschinengehäuse /
 Corps de la machine / Cuerpo de la máquina

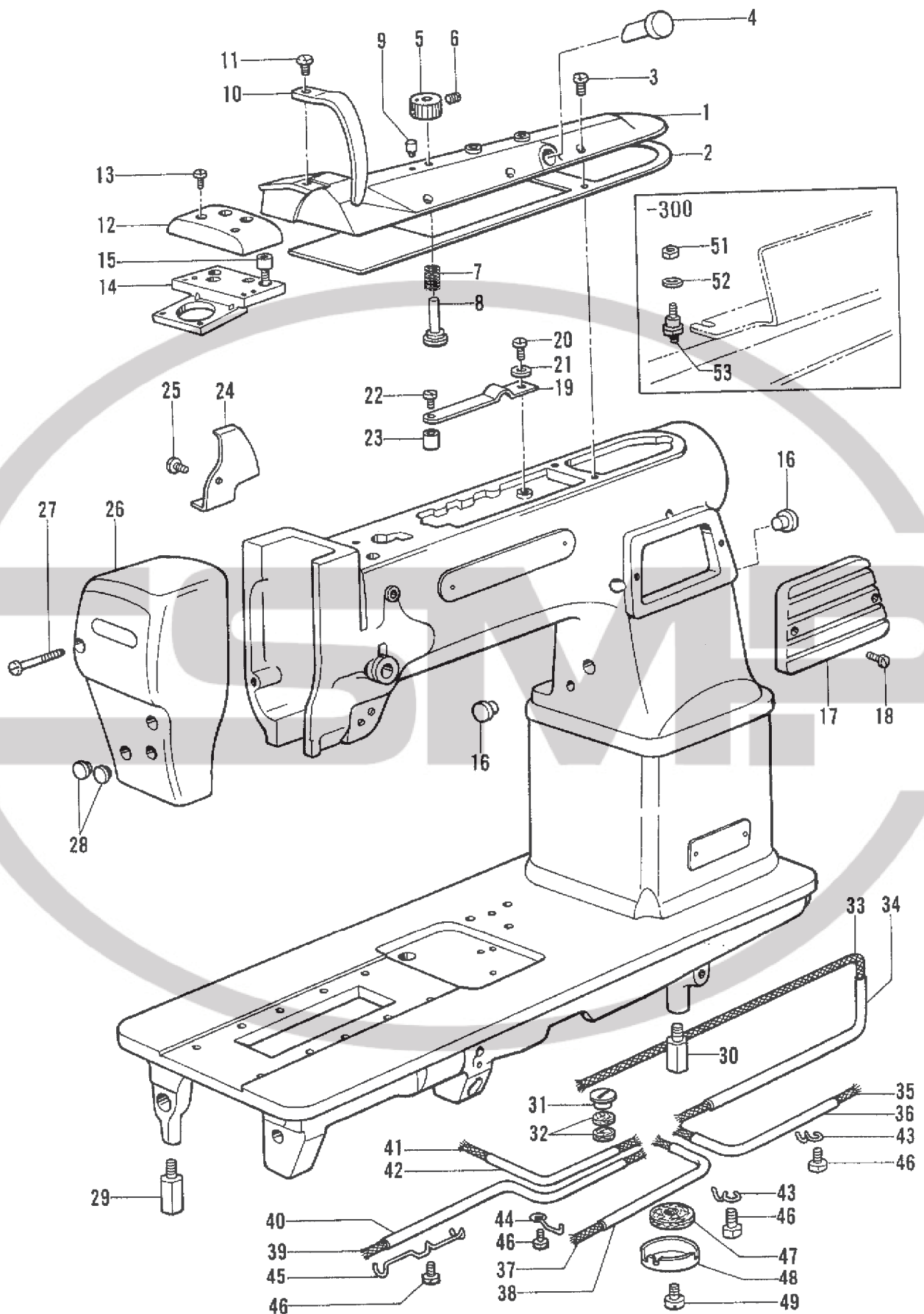

A. 主体関係/Machine body/Maschinengehäuse/
Corps de la machine/Cuerpo de la máquina

REF.NO.	CODE	Q'TY	品名	NAME OF PARTS	RMKS
1	S29310001	1	ウフイタ	UPPER PLATE	
2	S26537001	1	ウフイタシートパッキング	SHEET PACKING	
3	S26538001	5	シメネジ"357-40X10	SCREW 357X10	
4	S26209001	1	オイルゲージ"マト"	OIL GAUGE DIAL	
5	S26555001	1	キユウエシヤタ"ンタ"イアル	DIAL	
6	S25917001	1	トメネジ"595-28X7	SET SCREW 595X7	
7	S26557001	1	ハ"ネ	SPRING	
8	S26556001	1	キユウエシヤタ"ンシ"ク	LUBRICATION DIAL SHAFT	
9	S26559001	1	ピン	PIN	
10	S29335001	1	デンヒ"ンカハ"ー	THREAD TAKE-UP COVER	
11	S25902001	1	サラネジ"437-40X12	SCREW 437X12	
12	S29703001	1	ウフイタS	UPPER PLATE (S)	
13	S27007001	2	シメネジ"3X6	SCREW 3X6	
14	S29312001	1	モータ"ク"イ	MOTOR BRACKET	
15	S26971001	2	アナボルト6X14	BOLT 6X14	
16	S29313001	2	ゴム"セ"ン	RUBBER CAP	
17	S29314001	1	アームカハ"ー"イタ	ARM COVER PLATE	
18	S25920001	2	シメネジ"357-40X8	SCREW 357X8	
19	S26565001	1	イタハ"ネ	PLATE SPRING	
20	S25920001	1	シメネジ"357-40X8	SCREW 357X8	
21	S26220001	1	サ"カ"ネ	WASHER	
22	S26057001	1	シメネジ"318-40X8	SCREW 318X8	
23	S26207001	1	オイル"チ"ョウ"セツ"タイ	OIL ADJUST PLATE	
24	S26027001	1	オイル"ヨ"ク"イ"タ	OIL STOPPE PLATE	
25	S26028001	1	シメネジ"340-36X6	SCREW 340X6	
26	S29315001	1	メン"イ"タ	FACE PLATE	
27	S27093001	2	シメネジ"5X25	SCREW 5X25	
28	104449009	2	メクラ"セ"ン	OIL CAP	
29	S29316001	1	キャク"チ"ュウ	BED LEG	
30	S29317001	3	キャク"チ"ュウ	BED LEG	
31	S29318001	1	メクラ"セ"ン	OIL CAP	
32	S29319001	2	フェルト	FELT	
33	S29320001	1	クミ"ヒ"モ	WICK	
34	S26561001	1	ヒ"ニ"ール"チ"ュ"ー"ブ"	VINYL TUBE	
35	S29321001	1	クミ"ヒ"モ	WICK	
36	S29322001	1	ヒ"ニ"ール"チ"ュ"ー"ブ"	VINYL TUBE	
37	S29323001	1	クミ"ヒ"モ	WICK	
38	S29324001	1	ヒ"ニ"ール"チ"ュ"ー"ブ"	VINYL TUBE	
39	S29325001	1	クミ"ヒ"モ	WICK	
40	S29326001	1	ヒ"ニ"ール"チ"ュ"ー"ブ"	VINYL TUBE	
41	S29327001	1	クミ"ヒ"モ	WICK	
42	S29328001	1	ヒ"ニ"ール"チ"ュ"ー"ブ"	VINYL TUBE	
43	S29329001	3	チ"ュ"ー"ブ"オ"サ"エ	TUBE HOLDER	
44	S29330001	1	クミ"ヒ"モ	WICK	
45	S29331001	1	チ"ュ"ー"ブ"オ"サ"エ	TUBE HOLDER	
46	S25906001	4	シメネジ"357-40X6	SCREW 357X6	
47	S29332001	1	フェルト	FELT	
48	S29333001	1	オイル"ウ"ケ	OIL RECEIVER	
49	S29334001	1	シメネジ"635-32X13	SCRE 635X13	
<-300>					
51	021060302	2	ナット3"シ"ュ6	NUT	
52	025060132	2	ヒラサ"カ"ネ"シ"ョウ6	PLAIN WASHER 6	
53	S29043001	2	スタット"S	STAD (S)	

B. 上軸天ビン関係 / Upper shaft and thread take-up mechanism / Obere Welle und Fodenabnahmevorrichtung / Mécanisme de l'arbre supérieur et releveur de fil / Mecanismo del árbol superior y tirahilos

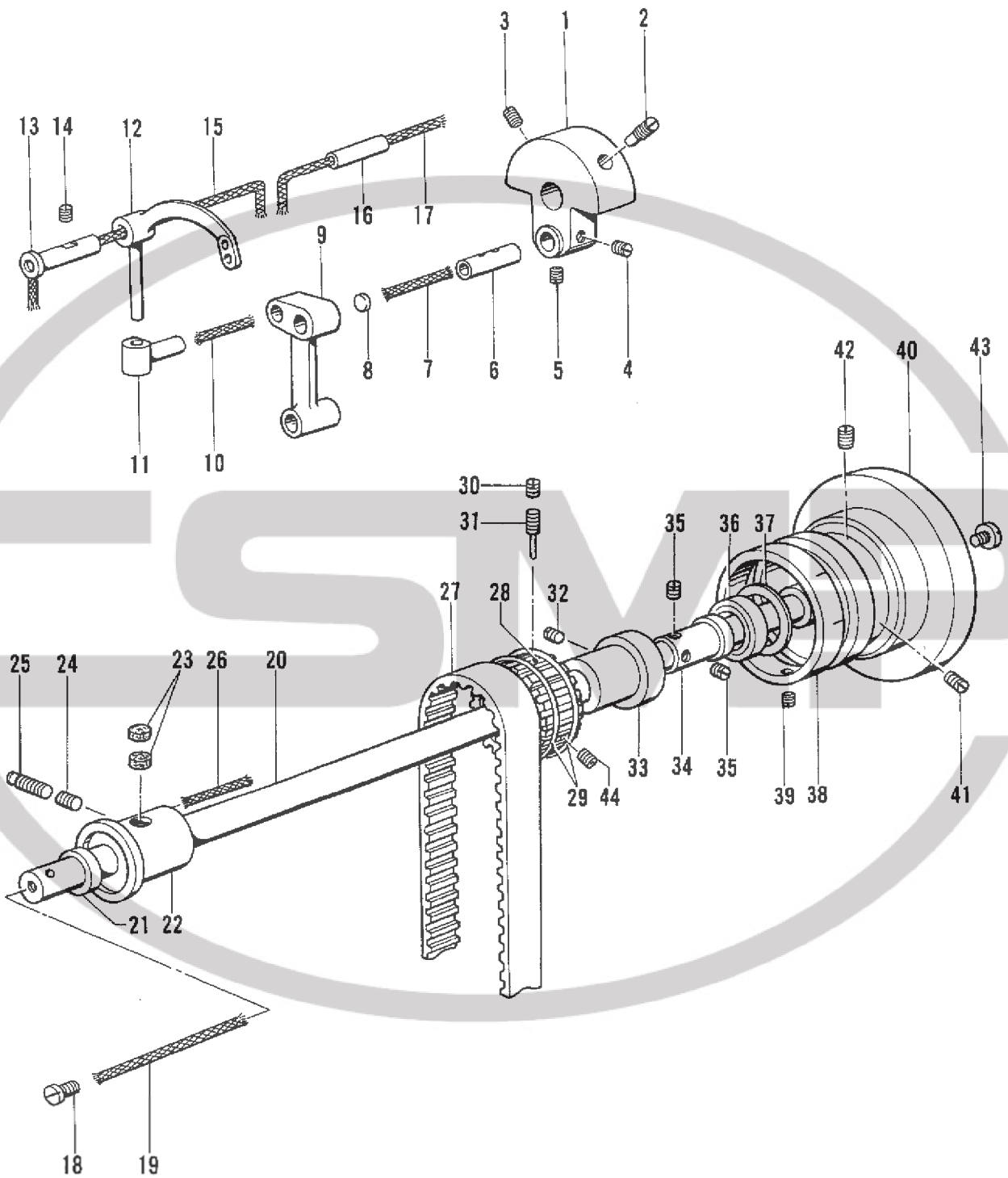

B. 上軸天ビン関係 / Upper shaft and thread take-up mechanism / Obere Welle und Fodenabnahmevorrichtung /
 Mécanisme de l'arbre supérieur et releveur de fil / Mecanismo del árbol superior y tirahilos

REF.NO.	CODE	Q'TY	ヒンメイ	NAME OF PARTS	RMKS
1	S25998001	1	デンビ"ンクランク	THREAD TAKE-UP CRANK	
2	S25999001	1	トメネジ"675-24X20	SET SCREW 675X20	
3	S26000001	1	トメネジ"675-24X14	SET SCREW 675X14	
4	S26002001	1	トメネジ"675-24X6	SET SCREW 675X6	
5	S26155001	1	トメネジ"675-24X4	SET SCREW 675X4	
6	S26001001	1	ハリホ"ウクランク	NEEDLE BAR CRANK	
7	S26142001	1	クミヒモ6X6	WICK 6X6	
8	S26551001	1	ゴムセン	OIL CAP	
9	S26008001	1	ハリホ"ウクランク	NEEDLE BAR CRANK	
10	S26143001	1	クミヒモ6X6	WICK 6X6	
11	S29336001	1	デンビ"ンダ"キ	THREAD TAKE-UP CLAMP	
12	S29337001	1	デンビ"ン	THREAD TAKE-UP	
13	S26539001	1	ピン	PIN	
14	S26002001	1	トメネジ"675-24X6	SET SCREW 675X6	
15	S26212001	1	クミヒモ6X6	WICK 6X6	
16	S26546001	1	ビ"ニールパイプ	VINYL PIPE	
17	S26210001	1	クミヒモ6X6	WICK 6X6	
18	S25992001	1	シメネジ"785-20X6	SCREW 785X6	
19	S26545001	1	クミヒモ12X12	WICK 12X12	
20	S26573001	1	ウワジ"ク	UPPER SHAFT	
21	S26037001	1	デンビ"ンクランクリング"	THREAD TAKE-UP CRANK RING	
22	S26036001	1	ウワジ"クメタルL	UPPER SHAFT BUSH (L)	
23	S26141001	2	フェルト	FELT	
24	S26002001	1	トメネジ"675-24X6	SET SCREW 675X6	
25	S26221001	1	ハ"ネカク675-24X19	SPRING HOOK 675X19	
26	S26144001	1	クミヒモ	WICK	
27	S26340001	1	タイミンク"ヘルト	TIMING BELT	
28	S26042001	1	タイミンク"プ"ーリーU	TIMING PULLEY (U)	
29	S26047001	2	タイミンク"プ"ーリーリング"	TIMING PULLEY RING	
30	S26003001	1	アナトメネジ"675-24X9	SET SCREW 675X9	
31	S26043001	1	トメネジ"675-24X14	SET SCREW 675X14	
32	S26045001	1	トメネジ"675-24X19	SET SCREW 675X19	
33	S26457001	1	ウワジ"クヘ"アリング"ケース	UPPER SHAFT BEARING CASE	
34	S26458001	1	ウワジ"クヘ"アリング"カラー	UPPER SHAFT BEARING COLLAR	
35	S26039001	2	トメネジ"635-32X5	SET SCREW 635X5	
36	S26040001	1	ヘ"アリング"6202ZZA	BEARING 6202ZZA	
37	S26041001	1	リング"	RING	
38	S29338001	1	メモリリング"	DIAL RING	
39	S26039001	1	トメネジ"635-32X5	SET SCREW 635X5	
40	S29339001	1	プ"ーリー	PULLEY	
41	S27732001	1	トメネジ"595-28X19	SET SCREW 595X19	
42	S27733001	1	トメネジ"595-28X19	SET SCREW 595X19	
43	S26049001	1	シメネジ"675-24X11	SET SCREW 675X11	
44	S26045001	1	トメネジ"675-24X20	SET SCREW 675X20	

C. 針棒関係 / Needle bar mechanism / Nadelstangenvorrichtung /
Mécanisme de la barre à aiguille / Mecanismo de la barra de aguja

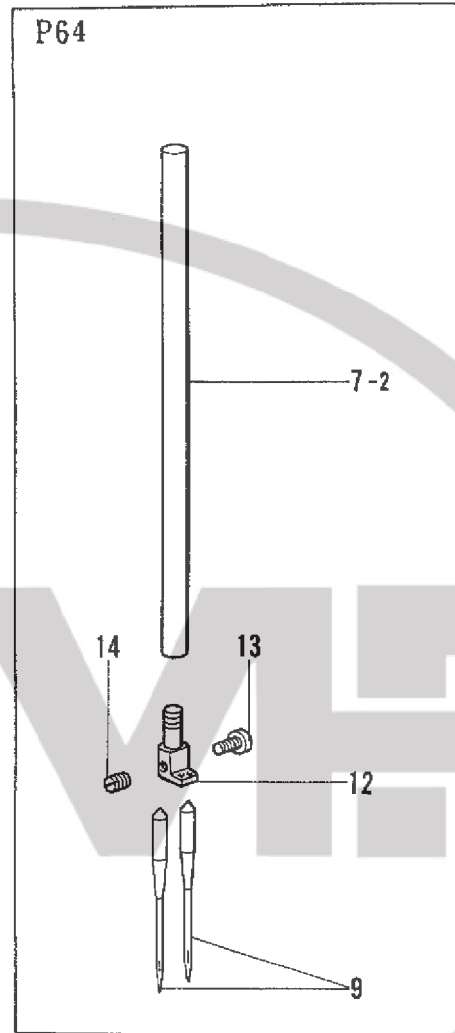
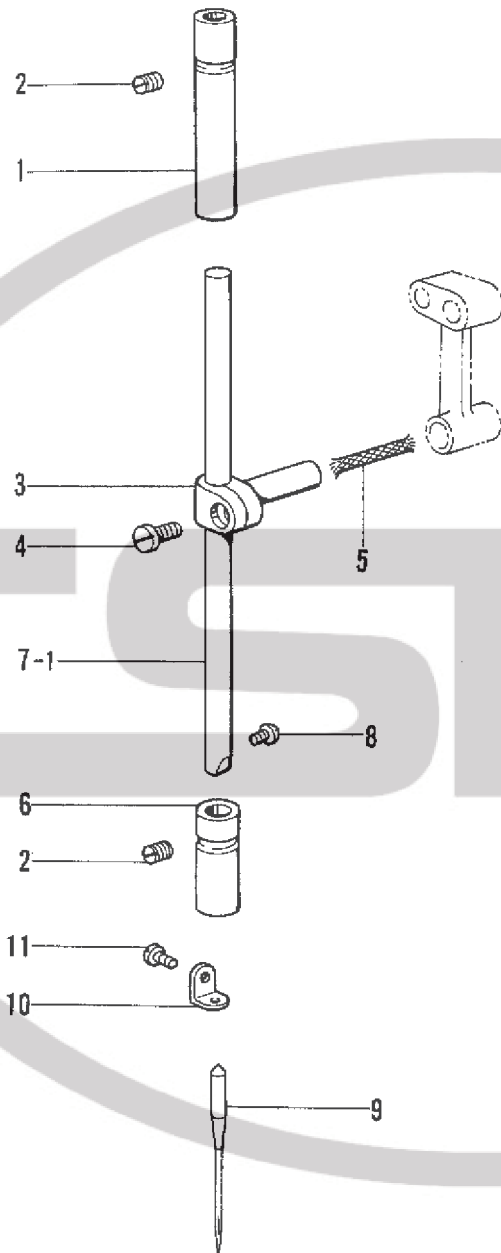

C. 針棒関係/Needle bar mechanism/Nadelstangenvorrichtung/
 Mécanisme de la barre à aiguille/Mecanismo de la barra de aguja

REF.NO.	CODE	Q'TY	品名	NAME OF PARTS	RMKS
1	S26285001	1	ハリホ"ウメタルU	NEEDLE BAR BUSH (U)	
2	S26153001	2	トメネジ"675-24X11	SET SCREW 675X11	
3	S26185001	1	ハリホ"ウタ"キ	NEEDLE BAR CLAMP	
4	S26012001	1	シメネジ"396-40X9	SCREW 396X9	
5	S26142001	1	クミヒモ6X6	WICK 6X6	
6	S26017001	1	ハリホ"ウシタメタル	NEEDLE BAR LOWER BUSH	
<P62>					
7-1	S26188001	1	ハリホ"ウ	NEEDLE BAR	
8	S26015001	1	シメネジ"340-36X4	SCREW 340X4	
9	145646016	1	ミシンハリDPX17#16	NEEDLE DPX17#16	
10	S26189001	1	ハリホ"ウイトアンナイ	NEEDLE BAR THREAD GUIDE	
11	S26014001	1	シメネジ"225-48X2	SCREW 225-48X2	
<P64>					
7-2	S29340001	1	ハリホ"ウ	NEEDLE BAR	
9	145646016	2	ミシンハリDPX17#16	NEEDLE DPX17#16	
12	S26342001	1	ハリタ"キ1/16"	NEEDLE CLAMP 1/16"	
12	S26343001	1	ハリタ"キ5/64"	NEEDLE CLAMP 5/64"	
12	S26344001	1	ハリタ"キ3/32"	NEEDLE CLAMP 3/32"	
13	S26015001	1	シメネジ"340-36X14	SCREW 340X14	
14	S29341001	1	トメネジ"340-36X4	SET SCREW 370X4	

D. 押工関係/Presser foot mechanism/Stoffdrückerfuß/
 Mécanisme du pied presseur/Mecanismo del prensa telas

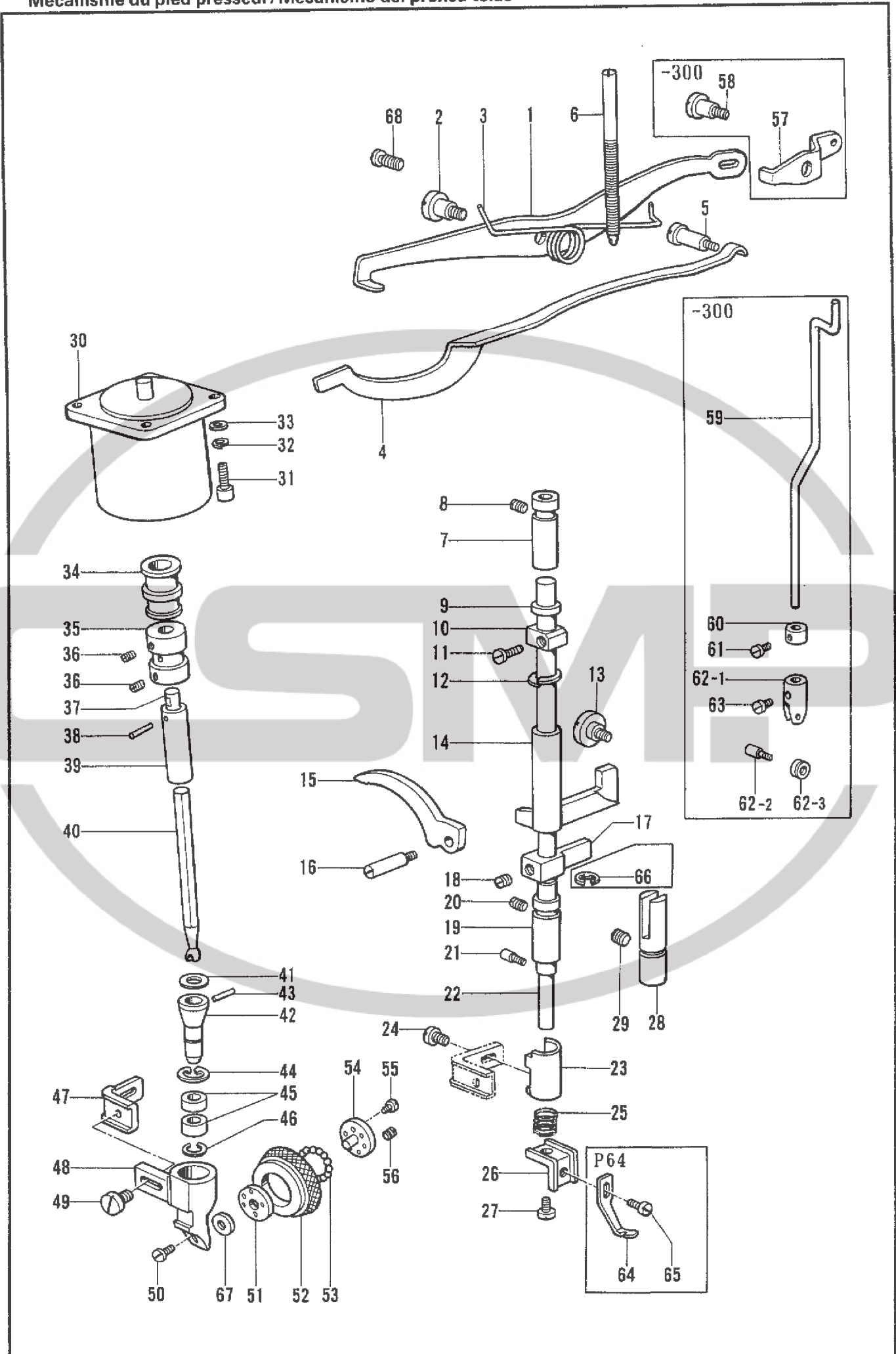

D. 押工関係 / Presser foot mechanism / Stoffdrückerfuß /
 Mécanisme du pied presseur / Mecanismo del prensa telas

REF.NO.	CODE	Q'TY	ヒンメイ	NAME OF PARTS	RMKS
1	S26129001	1	オサエアケ"レハ"	PRESSER FOOT LIFTER LEVER	
2	S26131001	1	タ"ンネジ"675-24X6	STUD SCREW 675X6	
3	S26453001	1	ネジ"リハ"ネ	TWIST SPRING	
4	S26124001	1	オサエイタハ"ネ	PLATE SPRING	
5	S26125001	1	タ"ンネジ"675-24X13	STUD SCREW 675X13	
6	S26222001	1	ヒ"ンネジ"635-32X44	PIN SCREW 635X14	
7	S26016001	1	オサエホ"ウメタルU	PRESSER BAR BUSH (U)	
8	S26153001	1	トメネジ"675-24X11	SET SCREW 675X11	
9	S29345001	1	オサエホ"ウカラ	PRESSER BAR COLLAR	
10	S26026001	1	オサエホ"ウタ"キ	PRESSER BAR CLAMP	
11	S26012001	1	シメネジ"395-40X9	SCREW 395X9	
12	S26187001	1	サ"カ"ネ	WASHER	
13	S26025001	1	タ"ンネジ"675-24X8	STUD SCREW 675X8	
14	S26186001	1	オサエホ"ウタ"キ	PRESSER BAR CLAMP	
15	S26449001	1	オサエアケ"レハ"	PRESSER FOOT LIFTER LEVER	
16	S26092001	1	ヒ"ンネジ"450-32X7	PIN SCREW 450X7	
17	S29346001	1	オサエホ"ウアンナイ	PRESSER BAR GUIDE	
18	S27251001	1	トメネジ"6-0.75X5	SET SCREW 6X5	
19	S26585001	1	オサエホ"ウメタルD	PRESSER BAR BUSH (D)	
20	S26153001	1	トメネジ"675-24X11	SET SCREW 675X11	
21	S27147001	1	ヒ"ンネジ" M4	PIN SCREW M4	
22	S29347001	1	オサエホ"ウ	PRESSER BAR	
23	S27146001	1	ローラーウケ"タ"イ	ROLLER BRACKET BASE	
24	S27211001	1	シメネジ"4X8	SCREW 4X8	
25	S27148001	1	コイルハ"ネ	SPRING	
26	S27149001	1	ホシ"ヨオサエウケ	SUB PRESSER HOLDER	
27	S27140001	1	シメネジ"4X10	SCREW 4X10	
28	S29348001	1	アンナイホ"ウ	GUIDE BAR	
29	S26153001	1	トメネジ"675-24X11	SET SCREW 675X11	
30	S29349001	1	ステッピング"モータ	STEPPING MOTOR	
31	S29350001	4	アナホ"ルト4X14	BOLT 4X14	
32	S27068001	4	ハ"ネサ"カ"ネ4	SPRING WASHER 4	
33	S27067001	4	サ"カ"ネ4	WASHER 4	
34	S29351001	1	シ"ョイントフ"ーツ	JOINT BOOT	
35	S29352001	1	シ"ョイント	JOINT	
36	S27293001	4	トメネジ"4X5	SET SCREW 4X5	
37	S29353001	1	スリーブ"ツキ"テ	SLEEVE JOINT	
38	S29354001	1	ピン	PIN	
39	S29356001	1	スライド"スリーブ"	SLIDE SLEEVE	
40	S29355001	1	スライド"シ"ク	SLEDE SHAFT	
41	S27217001	1	ローラー"シ"クリング"	ROLLER SHAFT RING	
42	S29267001	1	ローラーキヤ"ーS	ROLLER GEAR (S)	
43	S27216001	1	ピン2.5X12	PIN 2.5X12	
44	S27208001	1	トメフC16	STOP RING C16	
45	S27214001	2	ローラーキ"ヤ"ーBR	ROLLER GEAR BEARING	
46	S27215001	1	トメフ	STOP RING	
47	S29357001	1	ホルダ"ーウケ	HOLDER BRACKET	
48	S29358001	1	ローラーホルダ"ー	ROLLER HOLDER	
49	S27211001	1	シメネジ"4X8	SCREW 4X8	
50	S27224001	1	シメネジ"2.5X2.5	SCREW 2.5X2.5	
51	S27219001	1	ローラーウケA	ROLLER BRACKET (A)	
52	S29268001	1	ローラーキ"ヤ"ーL	ROLLER GEAR (L)	
53	S27221001	24	ゴウキュウ	STEEL BALL	
54	S27220001	1	ローラーウケB	ROLLER BRACKET (B)	
55	S27222001	3	サラネジ"2.5X4	SCREW 2.5X4	
56	S27223001	3	トメネジ"2.5X2.5	SCREW 2.5X2.5	
66	S26250001	1	トメフ	STOP RING	
68	S26220001	1	ハ"ネカケ	SPRING HOOK	
<-300>					
57	S26130001	1	ヒサ"アケ"レンクツレハ"	KNEE LIFTER CONNECTING LEVER	
58	S26131001	1	タ"ンネジ"675-24X6	STUD SCREW 675X6	
59	S29359001	1	ローラー"シ"ク	ROLLER SHAFT	

D. 押工関係 / Presser foot mechanism / Stoffdrückerfuß /
 Mécanisme du pied presseur / Mecanismo del prensa telas

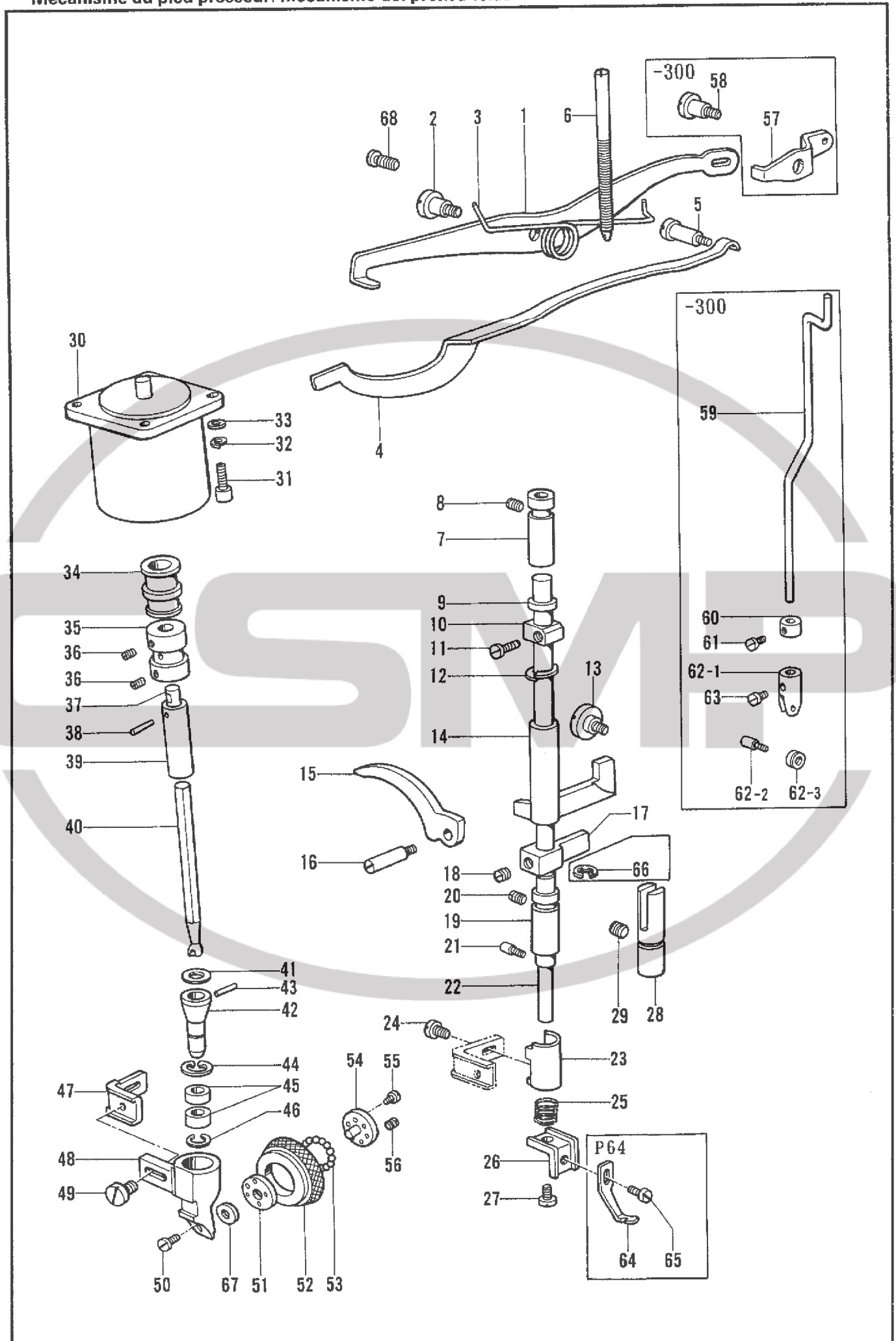

D. 押工関係/Presser foot mechanism/Stoffdrückerfuß/
Mécánisme du pied presseur/Mecanismo del prensa telas

REF.NO.	CODE	Q'TY	ヒンメイ	NAME OF PARTS	RMKS
60	S26132001	1	セットカラー	SET COLLAR	
61	S26035001	1	シメネジ"437-32X6	SCREW 437X6	
62	S26134001	1	ローラー"ラケットクミ	ROLLER BRACKET ASSEMBLY	
62-1	S26133001	1	ローラー"ラケット	ROLLER BRACKET	
62-2	S26136001	1	ピンネジ"340-36X4	PIN SCREW 340X4	
62-3	S26135001	1	ローラー	ROLLER	
63	S26035001	1	シメネジ"437-32X6	SCREW 437X6	
<P64>					
64	S29278001	1	ホジ"ヨオサE1/16"	SUB PRESSER FOOT 1/16"	
64	S29279001	1	ホジ"ヨオサE5/64"	SUB PRESSER FOOT 5/64"	
64	S29280001	1	ホジ"ヨオサE3/32"	SUB PRESSER FOOT 3/32"	
65	S27454001	1	シメネジ"357-40X6	SCREW 357X6	
<オプションパーツ /OPTION PARTS>					
51	S27219001	1	ローラーウケA	ROLLER BRACKET (A)	
52	S29269001	1	ローラーキ"ヤール	ROLLER GEAR (L)	
53	S27221001	24	コウキユウ	STEEL BALL	
54	S27220001	1	ローラーウケB	ROLLER BRACKET (B)	
55	S27222001	3	サラネジ"2.5X4	SCREW 2.5X4	
56	S27223001	3	トメネジ"2.5X2.5	SCREW 2.5X2.5	
67	S27225001	1	Rキ"ヤースペーサー	(R) GEAR SPACER	
67	S27389001	1	Rキ"ヤースペーサー0.3	(R) GEAR SPACER 0.3	
67	S27390001	1	Rキ"ヤースペーサー0.4	(R) GEAR SPACER 0.4	
67	S27397001	1	Rキ"ヤースペーサー0.15	(R) GEAR SPACER 0.15	
67	S27398001	1	Rキ"ヤースペーサー0.2	(R) GEAR SPACER 0.2	

E. 押工上げ関係 / Work clamp lifter mechanism / Stoffhalterhebevorrichtung /
 Mécanisme de levier du pinceur / Mecanismo del levantador de ménsula de trabajo

<-700>

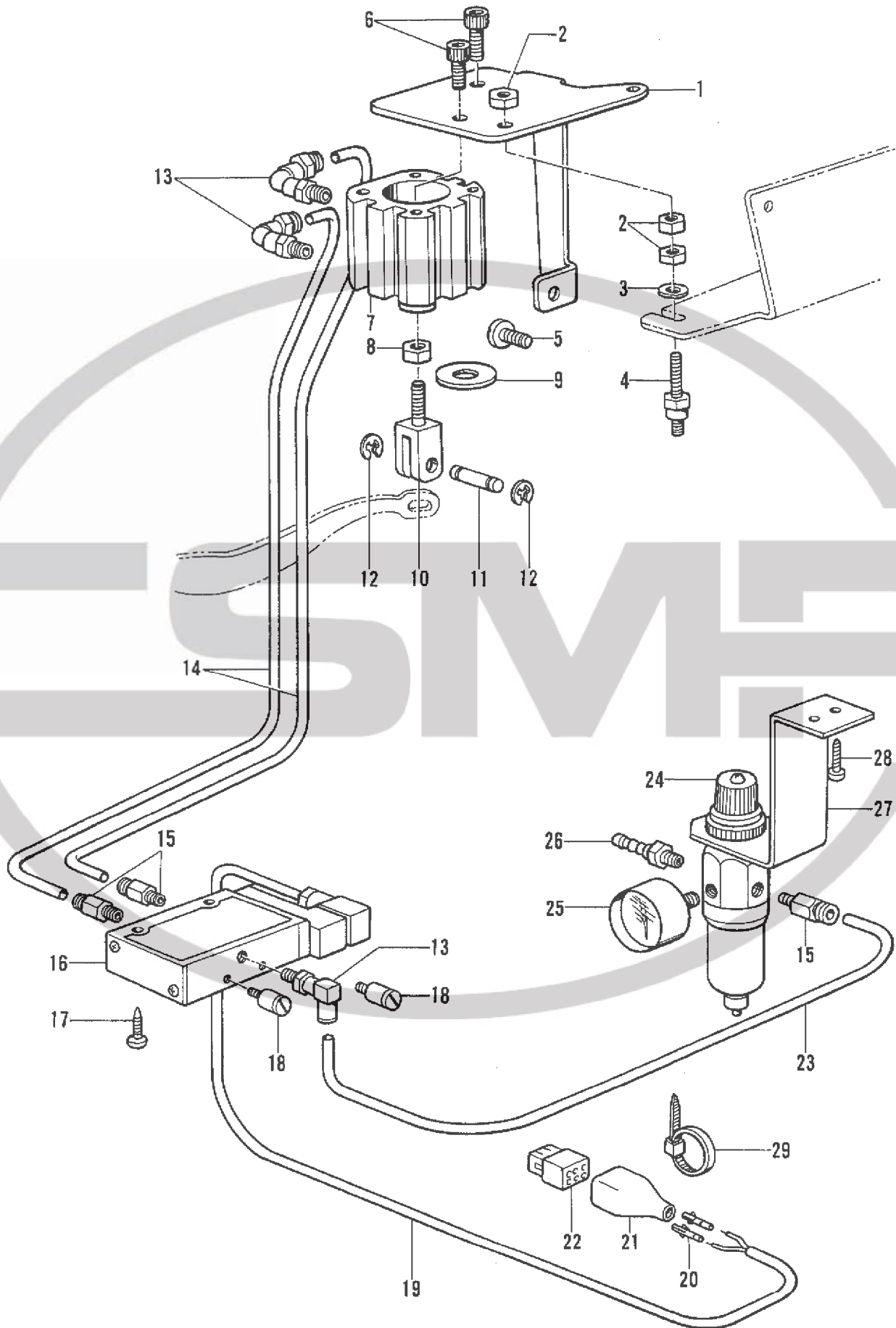

E. 押工上げ関係/Work clamp lifter mechanism/Stoffhalterhebevorrichtung/
 Mécanisme de leveur du pinceur/Mecanismo del levantador de ménsula de trabajo

REF.NO.	CODE	Q'TY	品名	NAME OF PARTS	RMKS
<-700>					
1	S29360001	1	シリンダートリツケイタ	CYLINDER SETTING PLATE	
2	021060302	6	3シュナット6	NUT 6	
3	025060132	2	ヒラサ"ガ"ネシヨウ6	PLAIN WASHER 6	
4	S29361001	2	スタット"L	STUD (L)	
5	S26405001	1	シメネジ"675-24X10	SCREW 675X10	
6	S27069001	2	アナボ"ルト6X12	BOLT 6X12	
7	S29482001	1	シリンダ"	CYLINDER	
8	S29483001	1	ナット	NUT	
9	S27033001	1	クッションゴ"ムD	CUSHION RUBBER (D)	
10	S29484001	1	ナックル	KNUCLE	
11	S27035001	1	ナックルピン	KNUCLE PIN	
12	S25899001	2	トメワ	STOP RING	
13	S27741001	3	エルボ"	ELBOW	
14	S27557001	2	エア"チューブ"	AIR TUBE	
15	S27740001	3	ニツプル	NIPPLE	
16	S27037001	1	ソレノイド"バルブ"	SOLENOID VALVE	
17	S26949001	2	モクネジ"4.5	SCREW 4.5	
18	S26948001	2	サイレンサ"	SILENSER	
19	S27050001	1	ケーブ"ル	CABLE	
20	S27022001	2	コネクタピンオス	CONNECTOR PIN (MALE)	
21	S29249001	1	コネクタ"キャップ"	CONNECTOR CAP	
22	S29250001	1	コネクタ"ピン6P	CONNECTOR PIN 6P	
23	S27612001	1	エア"チューブ"	AIR TUBE	
24	S27040001	1	レキ"ュレータ	REGULATOR	
25	S27044001	1	アツリヨクケイ	PRESSURE GAUGE	
26	S27048001	1	ホースニツプル	HOSE NIPPLE	
27	147733001	1	エア"ユニットトリツケイタ	AIR UNIT SETTING PLATE	
28	101118001	2	マルモクネジ"4.5X20	SCREW 4.5X20	
29	S27052001	1	ケツソクバ"ント"	BAND	

F. 送り関係/Feed mechanism/Transportvorrichtung/
 Mécanisme de l'entraînement/Mecanismo de la alimentación

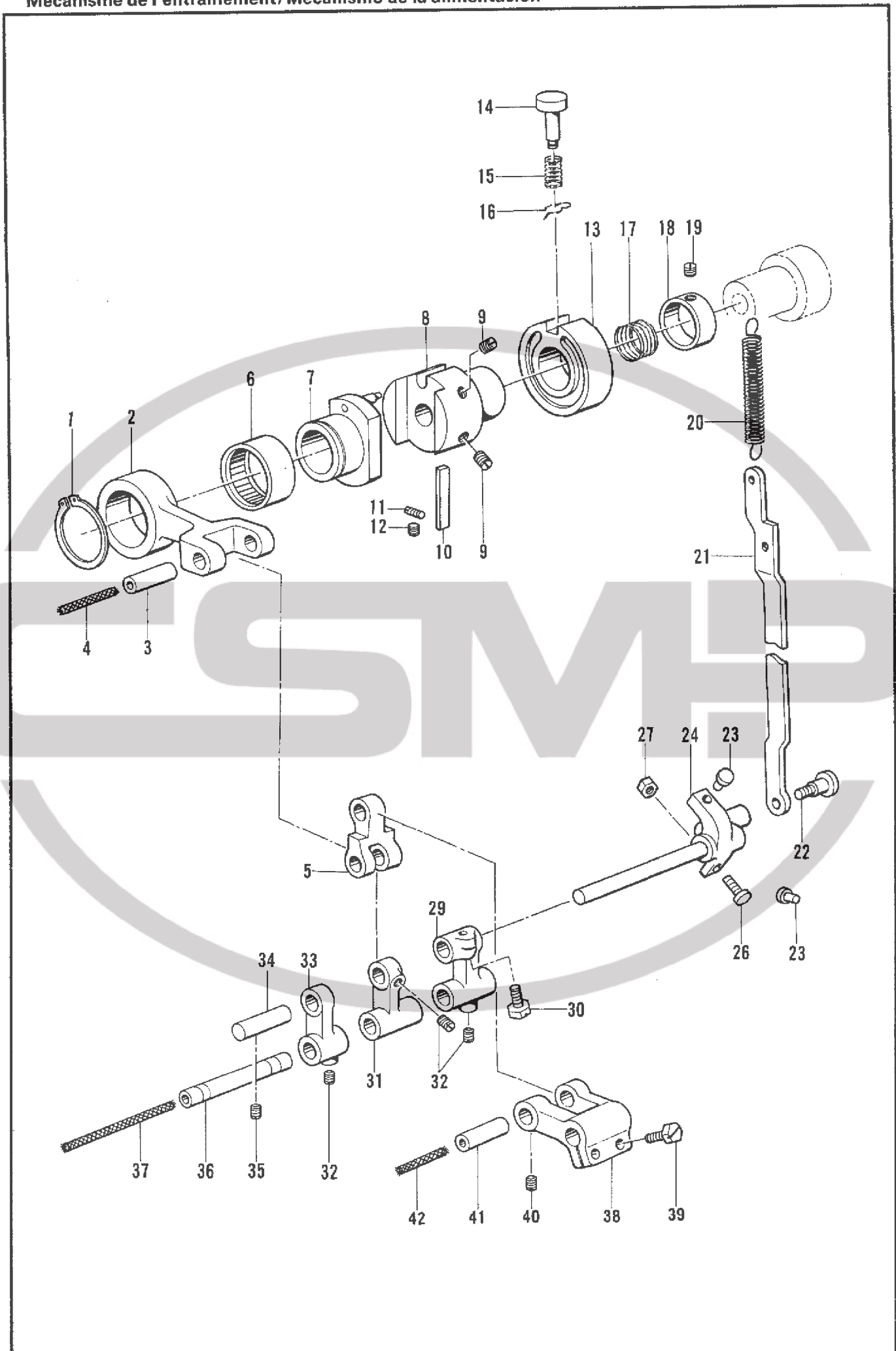

F. 送り関係 / Feed mechanism / Transportvorrichtung /
 Mécanisme de l'alimentation / Mecanismo de la alimentación

REF.NO.	CODE	Q'TY	ヒンメイ	NAME OF PARTS	RMKS
1	S26542001	1	トメワ	STOP RING	
2	S26269001	1	シタオクリロッド	LOWER FEED ROD	
3	S26271001	1	シタオクリロッド"ピン	LOWER FEED ROD PIN	
4	S29485001	1	クミヒモ	WICK	
5	S26273001	1	フタマダリンク	FORKED LINK	
6	S26162001	1	ニート"ルへ"アリンク	NEEDLE BEARING	
7	S26540001	1	オクリカム	FEED CAM	
8	S26077001	1	オクリカムト"タイ	FEED CAM BASE	
9	S26157001	2	トメネジ"635-32	SET SCREW 635-32	
10	S26081001	1	アンナイイタ	GUIDE PLATE	
11	S26079001	2	アトメネジ"318-40X8	SET SCREW 318X8	
12	S26080001	2	アトメネジ"318-40X5	SET SCREW 318X5	
13	S29486001	1	カム	CAM	
14	S26095001	1	オシボ"タン	PUSH BUTTOM	
15	S26096001	1	ハ"ネ	SPRING	
16	S26097001	1	オシボ"タントメピン	STOPPER PIN	
17	S26076001	1	ハ"ネ	SPRING	
18	S26075001	1	オシリンク	PUSH RING	
19	S26039001	2	トメネジ"635-32X5	SET SCREW 635X5	
20	S29487001	1	レンケツハ"ネ	SPRING	
21	S29488001	1	レンケツロッド	CONNECTING ROD	
22	S26131001	1	タ"ンネジ"675-24X6	STUD SCREW 675X6	
23	S29489001	2	クッション	CUSHION	
24	S29492001	1	ト"タ"イジ"ククミ	BASE SHAFT ASSEMBLY	
26	S29491001	1	ボ"ルト5X15	BOLT 5X15	
27	S25894001	1	ナット5	NUT 5	
29	S26575001	1	オクリクランクR	FEED CRANK (R)	
30	S26150001	1	ボ"ルト675-24X16	BOLT 675X16	
31	S29493001	1	メガ"ネリンク	SPECTACLE LINK	
32	S26272001	3	トメネジ"556-32X5	SET SCREW 556X5	
33	S26276001	1	オクリクランクL	FEED CRANK (L)	
34	S26268001	1	ピン	PIN	
35	S26156001	1	トメネジ"635-32X7	SET SCREW 635X7	
36	S29494001	1	クランクピン	CRANK PIN	
37	S29495001	1	クミヒモ	WICK	
38	S29496001	1	レンケツレバー	CONNECTING LEVER	
39	S26150001	2	ボ"ルト675-24X16	BOLT 675X16	
40	S26272001	2	トメネジ"556-32X5	SCREW 556X5	
41	S29485001	1	クミヒモ	WICK	
42	S26279001	1	ピン	PIN	
41	S27217001	1	ローラー"クリング"	ROLLER SHAFT RING	
42	S29267001	1	ローラー"キヤ"ーS	ROLLER GEAR (S)	

G. 送り軸関係 / Feed shaft mechanism / Transport welle /
 Mécanisme de l'arbre entraînement / Mecanismo de la eje alimentación

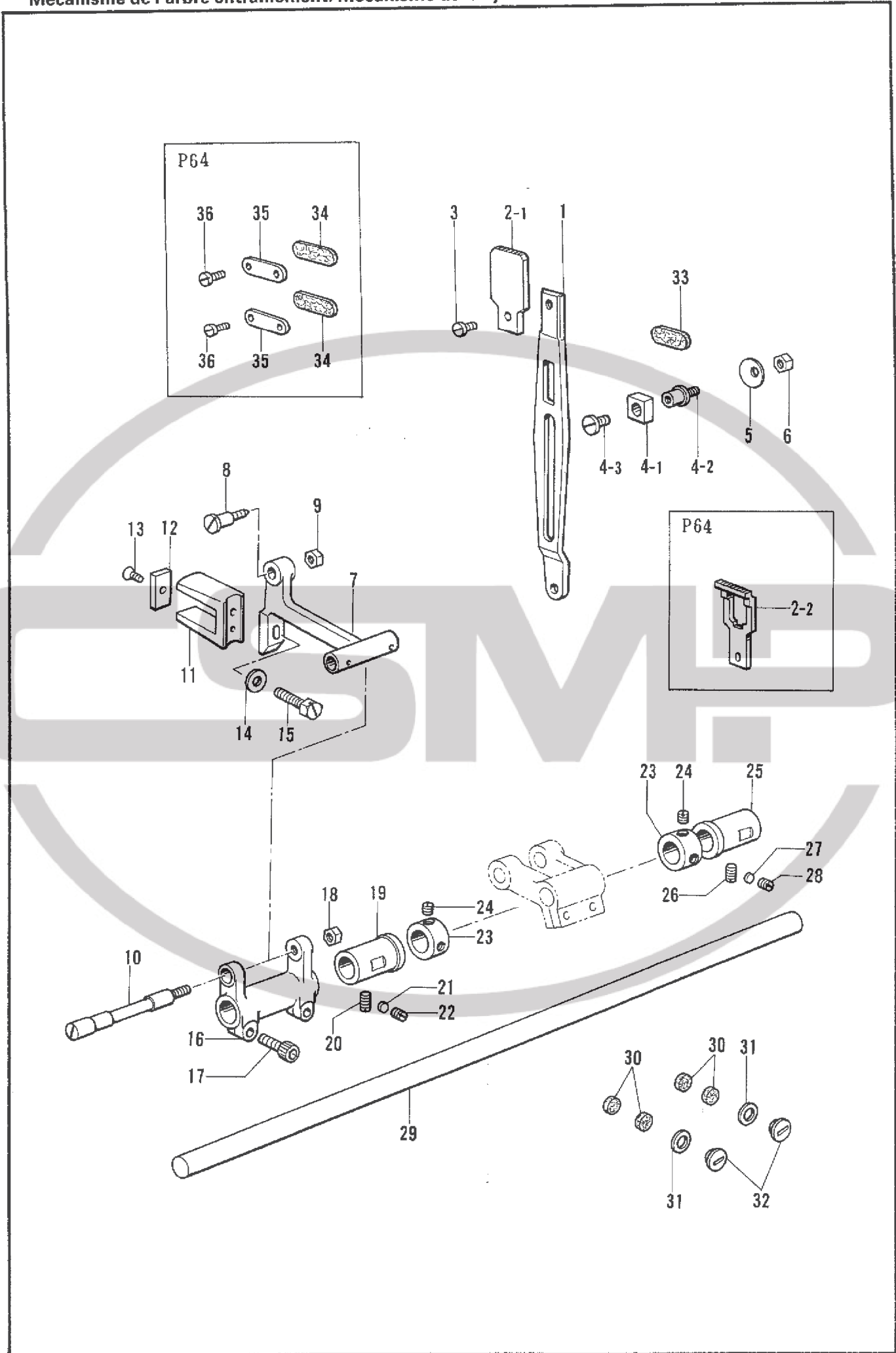

G. 送り軸関係 / Feed shaft mechanism / Transport welle /
Mécanisme de l'arbre entraînement / Mecanismo de la eje alimentación

REF.NO.	CODE	Q'TY	ヒンメイ	NAME OF PARTS	RMKS
1	S26333001	1	オクリイタ	FEED PLATE	
3	S26035001	1	シメネジ"437-32X6	SCREW 437X6	
4	S26335001	1	オクリイタカクコマクミ	FEED PLATE SLIDE BLOCK ASSEMBLY	
4-1	S26334001	1	オクリイタカクコマ	FEED PLATE SLIDE BLOCK	
4-2	S26336001	1	オクリイタカクコマダ"ンネシ"	STUD SCREW	
4-3	S25907001	1	シメネジ"318-44X4	SCREW 318X4	
5	S26122001	1	サ"カ"ネ	WASHER	
6	S26459001	1	ナット	NUT	
7	S26337001	1	オクリ"タ"イ	FEED BASE	
8	S26338001	1	タ"ンネシ"4.76	STUD SCREW 4.76	
9	S27727001	1	ナット476-32	NUT 476-32	
10	S29497001	1	ピンネシ"	PIN SCREW	
11	S26381001	1	フタマダブ"ラケット	FORKED BRACKET	
12	S26056001	1	フェルト	FELT	
13	S26057001	1	シメネジ"318-40X3	SCREW 318X3	
14	S26058001	1	ヒラサ"カ"ネ	PLAIN WASHER	
15	S27737001	1	ボ"ルト556-32X15	BOLT 556X15	
16	S29498001	1	オクリシ"クウテ"	FEED SHAFT ARM	
17	S26935001	2	アナボ"ルト5X14	BOLT 5X14	
18	S26083001	1	ナット675-24	NUT 675-24	
19	S26054001	1	オクリシ"クメタルF	FEED SHAFT BUSH (F)	
20	S26000001	1	トメネジ"675-24X14	SET SCREW 675X14	
21	S26213001	1	サ"カ"ネ	WASHER	
22	S26153001	1	トメネジ"675-24X11	SET SCREW 675X11	
23	S26055001	2	セットカラー	SET COLLAR	
24	S26155001	4	トメネジ"675-24X4	SET SCREW 675X4	
25	S26154001	1	オクリシ"クメタルB	FEED SHAFT BUSH (B)	
26	S26044001	1	トメネジ"675-24X20	SET SCREW 675X20	
27	S26213001	1	サ"カ"ネ	WASHER	
28	S26004001	1	トメネジ"675-24X9	SET SCREW 675X9	
29	S29499001	1	オクリシ"ク	FEED SHAFT	
30	S26214001	4	フェルト	FELT	
31	S29501001	3	パ"ッキン	PACKING	
32	S29500001	2	メクラセン	OIL CAP	
<P62>					
2-1	S29271001	1	オクリハ"	FEED DOG	
33	S29291001	1	フェルト	FELT	
<P64>					
2-2	S29284001	1	オクリハ"1/16"	FEED DOG 1/16"	
2-2	S29285001	1	オクリハ"5/64"	FEED DOG 5/64"	
2-2	S29286001	1	オクリハ"3/32"	FEED DOG 3/32"	
34	S29502001	2	フェルト	FELT	
35	S29503001	2	フェルトオサエ	FELT HOLDER	
36	S26533001	4	シメネジ"357-40X6	SCREW 357X6	

H. 下軸関係/Lower shaft mechanism/Untere Welle/
 Mécanisme de l'arbre inférieur/Mecanismo del eje inferior

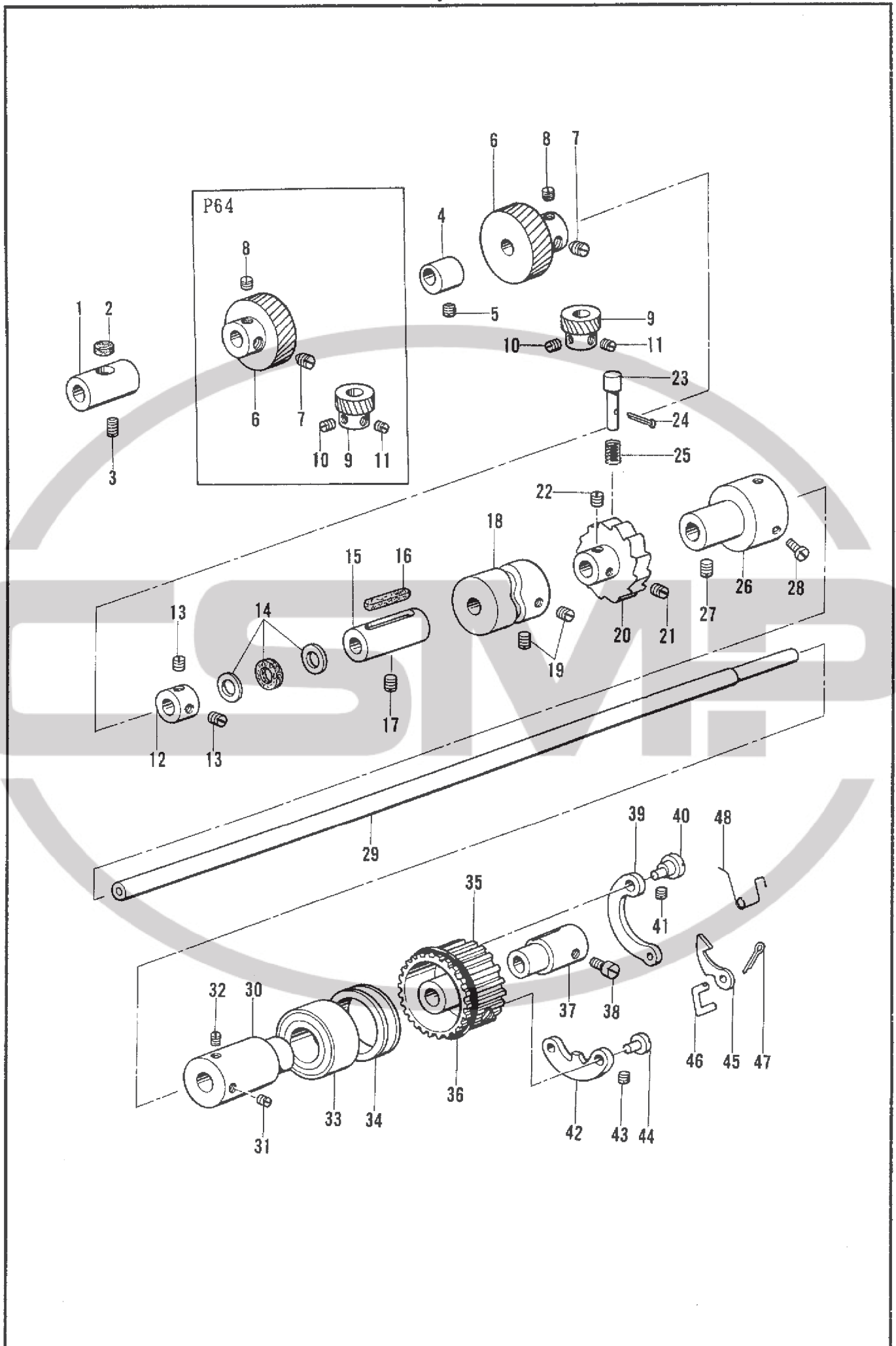

H. 下軸関係/Lower shaft mechanism/Untere Welle/
Mécanisme de l'arbre inférieur/Mecanismo del eje inferior

REF.NO.	CODE	Q'TY	ヒンメイ	NAME OF PARTS	RMKS
1	S26166001	1	シタジクメタルL	LOWER SHAFT BUSH (L)	
2	S26215001	1	フェルト	FELT	
3	S26044001	1	トメネジ"675-24X20	SET SCREW 675X20	
4	S29505001	1	ジ"ョウケ"オクリカム	VERTICAL FEED CAM	
5	S26090001	1	トメネジ"635-32X5	SET SCREW 635X5	
12	S29507001	1	シタジクカラー	LOWER SHAFT COLLAR	
13	S25917001	2	トメネジ"595-28X7	SET SCREW 595X7	
14	S29508001	1	シタジクベ"アリング"クミ	LOWER SHAFT BEARING ASSEMBLY	
15	S29509001	1	シタジクメタルM	LOWER SHAFT BUSH (M)	
16	S26144001	1	クミヒモ	WICK	
17	S26000001	1	トメネジ"675-24X14	SET SCREW 675X14	
18	S29510001	1	イトギリカム	THREAD TRIMMER CAM	
19	S26967001	2	トメネジ"635-28X9.5	SET SCREW 635X9.5	
20	S29511001	1	ラチェット	RATCHET	
21	S26085001	1	トメネジ"635-32X8	SET SCREW 635X8	
22	S26156001	1	トメネジ"635-32X7	SET SCREW 635X7	
23	S29512001	1	オシボ"タン	PRESSER BUTTON	
24	S26097001	1	オシボ"タントメピン	SET PIN	
25	S26096001	1	バ"ネ	SPRING	
26	S29513001	1	ベ"アリング"ケース	BEARING CASE	
27	S26044001	1	トメネジ"675-24X20	SET SCREW 675X20	
28	S26062001	3	シメネジ"340-36X5	SCREW 340X5	
29	S29514001	1	シタジク	LOWER SHAFT	
30	S26060001	1	ベ"アリング"ブ"ッシュ	BEARING BUSH	
31	S26039001	1	トメネジ"635-32X5	SET SCREW 635X5	
32	S26090001	1	トメネジ"635-32X5	SET SCREW 635X5	
33	S26040001	1	ベ"アリング"620ZZA	BEARING 620ZZA	
34	S26061001	1	ミゾ"ツキリング"	SLOTTED RING	
35	S26063001	1	タイミング"プ"ーリD	TIMING PULLEY	
36	S26047001	1	タイミング"プ"ーリング"	TIMING PULLEY RING	
37	S26064001	1	カラー	COLLAR	
38	S26065001	2	シメネジ"635-32X10	SCREW 635X10	
39	S26068001	1	ロックレバ"ーバ"ネ	ROCK LEVER SPRING	
40	S26067001	1	ロックレバ"ーバ"ネシ"ク	ROCK LEVER SPRING SHAFT	
41	S26052001	1	トメネジ"556-32X7	SET SCREW 556X7	
42	S26069001	1	ロックレバ"ー	ROCK LEVER	
43	S26052001	1	トメネジ"556-32X7	SET SCREW 556X7	
44	S26066001	1	ロックレバ"ーシ"ク	ROCK LEVER SHAFT	
45	S26070001	1	ラチェット	RATCHET	
46	S26071001	1	レンケツリンク	CONNECTING LINK	
47	S26073001	1	ワリピン	PIN	
48	S26072001	1	ラチェットバ"ネ	RATCHET SPRING	
<P62>					
6	S26084001	1	ギ"ヤ- L	GEAR (L)	
7	S26085001	1	トメネジ"635-32X8	SET SCREW 635X8	
8	S26156001	1	トメネジ"635-32X7	SET SCREW 635X7	
9	S29509001	1	ギ"ヤ- S	GEAR (S)	
10	S26090001	1	トメネジ"635-32X5	SET SCREW 635X5	
11	S26158001	1	トメネジ"635-32X4	SET SCREW 635X4	
<P64>					
6	S26084001	2	ギ"ヤ- L	GEAR (L)	
7	S26085001	2	トメネジ"635-32X8	SET SCREW 635X8	
8	S26156001	2	トメネジ"635-32X7	SET SCREW 635X7	
9	S29515001	2	ギ"ヤ- S	GEAR (S)	
10	S26090001	2	トメネジ"635-32X5	SET SCREW 635X5	
11	S26158001	2	トメネジ"635-32X4	SET SCREW 635X4	

J1. カマ関係 / Rotary hook mechanism / Greifervorrichtung /
 Mécanisme du crochet rotatif / Mecanismo del cangrejo

<P62>

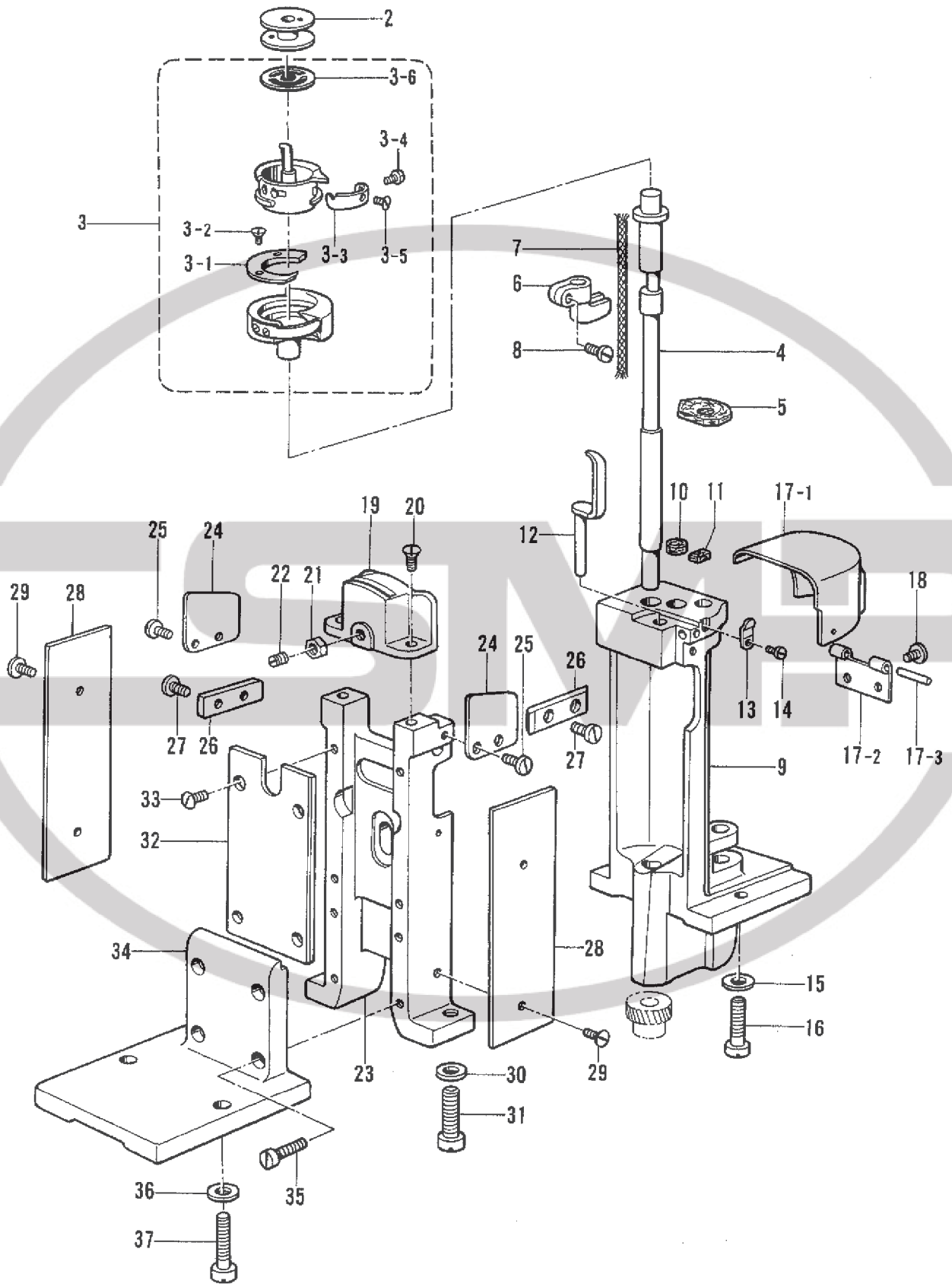

J1. カマ関係/Rotary hook mechanism/Greifervorrichtung/
Mécanisme du crochet rotatif/Mecanismo del cangrejo

REF.NO.	CODE	Q'TY	ヒンメイ	NAME OF PARTS	RMKS
<P62>					
2	S29266001	1	ホ"ヒン	BOBBIN	
3	S29272001	1	カマクミ	ROTARY HOOK ASSEMBLY	
3-1	S29753001	1	ウチカマオサエ	INNER ROTARY ASSEMBLY	
3-2	S27751001	3	シメネジ"	SCREW	
3-3	S29761001	1	チョウシハ"ネ	TENSION SPRING	
3-4	S27754001	1	トメネジ"	SET SCREW	
3-5	S29762001	1	チョウシネジ"	ADJUST SCREW	
3-6	S29767001	1	クウテンホ"ウシハ"ネ	BOBBIN TENSION SPRING	
4	S29516001	1	カマジ"ク	ROTARY HOOK SHAFT	
5	S29520001	1	フェルトC	FELT (C)	
6	S29522001	1	オープナーフタマタ	OPENER FORK	
7	S29523001	1	カマト"タ"イトウジン	ROTARY HOOK BRACKET WICK	
8	S29554001	1	シメネジ"4.37	SCREW 4.37	
9	S29517001	1	カマト"タ"イ	ROTARY HOOK BRACKET	
10	S29518001	1	フェルトA	FELT (A)	
11	S29519001	1	フェルトB	FELT (B)	
12	S29521001	1	オープナー	OPENER	
13	S27313001	1	カマカハ"ーウケハ"ネ	SPRING	
14	S27314001	1	シメネジ"3X5	SCREW 3X5	
15	S26342001	2	サ"カ"ネ	WASHER	
16	S26321001	2	シメネジ"785-20X26	SCREW 785X26	
17	S29529001	1	カマカハ"ークミ	ROTARY HOOK COVER ASSEMBLY	
17-1	S29273001	1	カマカハ"ー	ROTARY HOOK COVER	
17-2	S27545001	1	カマカハ"ーヒンジ"	ROTARY HOOK HINGE	
17-3	S27546001	1	ヒンジ"ヒ"ン	HINGE PIN	
18	S26533001	4	シメネジ"357-40X6	SCREW 357X6	
19	S29270001	1	ハリイタ	NEEDLE PLATE	
20	S27275001	2	サラネジ"4X6	SCREW 4X6	
21	S25996001	1	ナット635-32	NUT 635-32	
22	S26156001	1	トメネジ"635-32X7	SET SCREW 635X7	
23	S29524001	1	ハリイタ"タ"イ	NEEDLE PLATE BRACKET	
24	S29527001	1	ハリイタ"タ"イカハ"ーU	NEEDLE PLATE BRACKET COVER (U)	
25	S26533001	2	シメネジ"357-40X6	SCREW 357X6	
26	S29526001	1	ト"タ"イコテイイタ	FASTENING PLATE	
27	S26534001	2	シメネジ"357-40X6	SCREW 357X6	
28	S29528001	2	ハリイタ"タ"イカハ"ーD	NEEDLE PLATE BRACKET COVER (D)	
29	S26533001	4	シメネジ"357-40X6	SCREW 357X6	
30	S26342001	2	サ"カ"ネ	WASHER	
31	S26329001	2	シメネジ"	SCREW	
32	S29525001	1	ト"タ"イカハ"ー	BRACKET COVER	
33	S26331001	4	サラネジ"4.37-32	SCREW 4.37-32	
34	S26332001	1	ホシ"ヨト"タ"イ	SUB BRACKET	
35	S26022001	4	シメネジ"437-32X14	SCREW 437X14	
36	S26342001	2	サ"カ"ネ	WASHER	
37	S26321001	2	シメネジ"785-20X26	SCREW 785X26	

<P64>

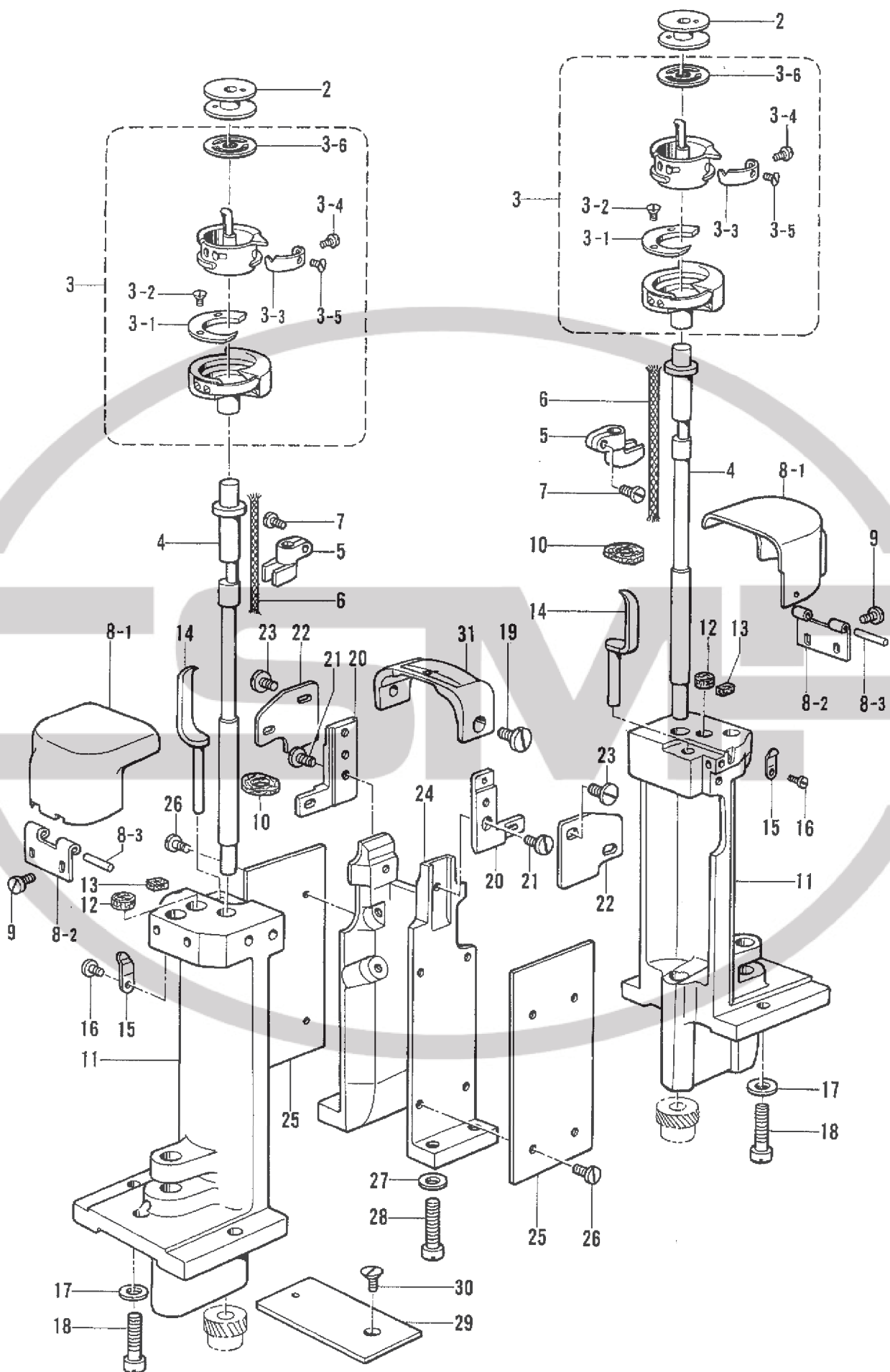

J2. カマ関係/Rotary hook mechanism/Greifervorrichtung/
Mécánisme du crochet rotatif/Mecanismo del cangrejo

REF.NO.	CODE	Q/TY	ヒンメイ	NAME OF PARTS	RMKS
<P64>					
2	S29266001	2	ホ"ヒン	BOBBIN	
3	S29272001	2	カマクミ	ROTARY HOOK ASSEMBLY	
3-1	S29753001	2	ウチカマオサエ	INNER ROTARY ASSEMBLY	
3-2	S27751001	6	シメネジ"	SCREW	
3-3	S29761001	2	チョウシハ"ネ	TENSION SPRING	
3-4	S27754001	2	トメネジ"	SET SCREW	
3-5	S27754001	2	トメネジ"	SET SCREW	
3-6	S29767001	2	クウデンホ"ウシハ"ネ	BOBBIN TENSION SPRING	
4	S29516001	2	カマジ"ク	ROTARY HOOK SHAFT	
5	S29522001	2	オープナーフタマタ	OPENER FORK	
6	S29523001	2	カマト"タ"イトウシン	ROTARY HOOK BRACKET WICK	
7	S29554001	2	シメネジ"4.37-32	SCREW 4.37-32	
8	S29529001	2	カマカハ"ークミ	ROTARY HOOK COVER ASSEMBLY	
8-1	S29273001	2	カマカハ"ー	ROTARY HOOK COVER	
8-2	S27545001	2	カマカハ"ーヒンジ"	ROTARY HOOK HINGE	
8-3	S27546001	2	ヒンジ"ピン	HINGE PIN	
9	S26533001	4	シメネジ"357-40X6	SCREW 357X6	
10	S29520001	2	フェルトC	FELT (C)	
11	S29517001	2	カマト"タ"イ	ROTARY HOOK BRACKET	
12	S29518001	2	フェルトA	FELT (A)	
13	S29519001	2	フェルトB	FELT (B)	
14	S29521001	2	オープナー	OPENER	
15	S27313001	2	カマカハ"ーウケハ"ネ	SPRING	
16	S27314001	2	シメネジ"3X5	SCREW 3X5	
17	S26342001	4	サ"カ"ネ	WASHER	
18	S26321001	4	シメネジ"785-20X26	SCREW 785X26	
19	S27275001	2	サラネジ"4X6	SCREW 4X6	
20	S29530001	2	ハリイタウケタ"イ	NEEDLE PLATE BRACKET	
21	S26534001	4	シメネジ"357-40X6	SCREW 357X6	
22	S29531001	2	ハリイタト"タ"イカハ"ーU	NEEDLE PLATE BRACKET COVER (U)	
23	S26333001	4	シメネジ"357-40X6	SCREW 357X6	
24	S29532001	1	ハリイタト"タ"イ	NEEDLE PLATE BRACKET	
25	S29533001	2	ハリイタト"タ"イカハ"ーD	NEEDLE PLATE BRACKET COVER (D)	
26	S26533001	8	シメネジ"357-40X6	SCREW 357X6	
27	S26342001	4	サ"カ"ネ	WASHER	
28	S26329001	4	シメネジ"785-20X18	SCREW 785X18	
29	S26346001	1	サシイタ1	COVER 1	
30	S25901001	1	サラネジ"437-40X8	SCREW 437X8	
31	S29281001	1	ハリイタ1/16	NEEDLE PLATE 1/16	
31	S29282001	1	ハリイタ5/64	NEEDLE PLATE 5/64	
31	S29283001	1	ハリイタ3/32	NEEDLE PLATE 3/32	

K. タッチバック関係/Quick back mechanism/Schnellumkehrvorrichtung/
 Dispositif de retour arrière rapide/Mecanismo de retroceso rápido

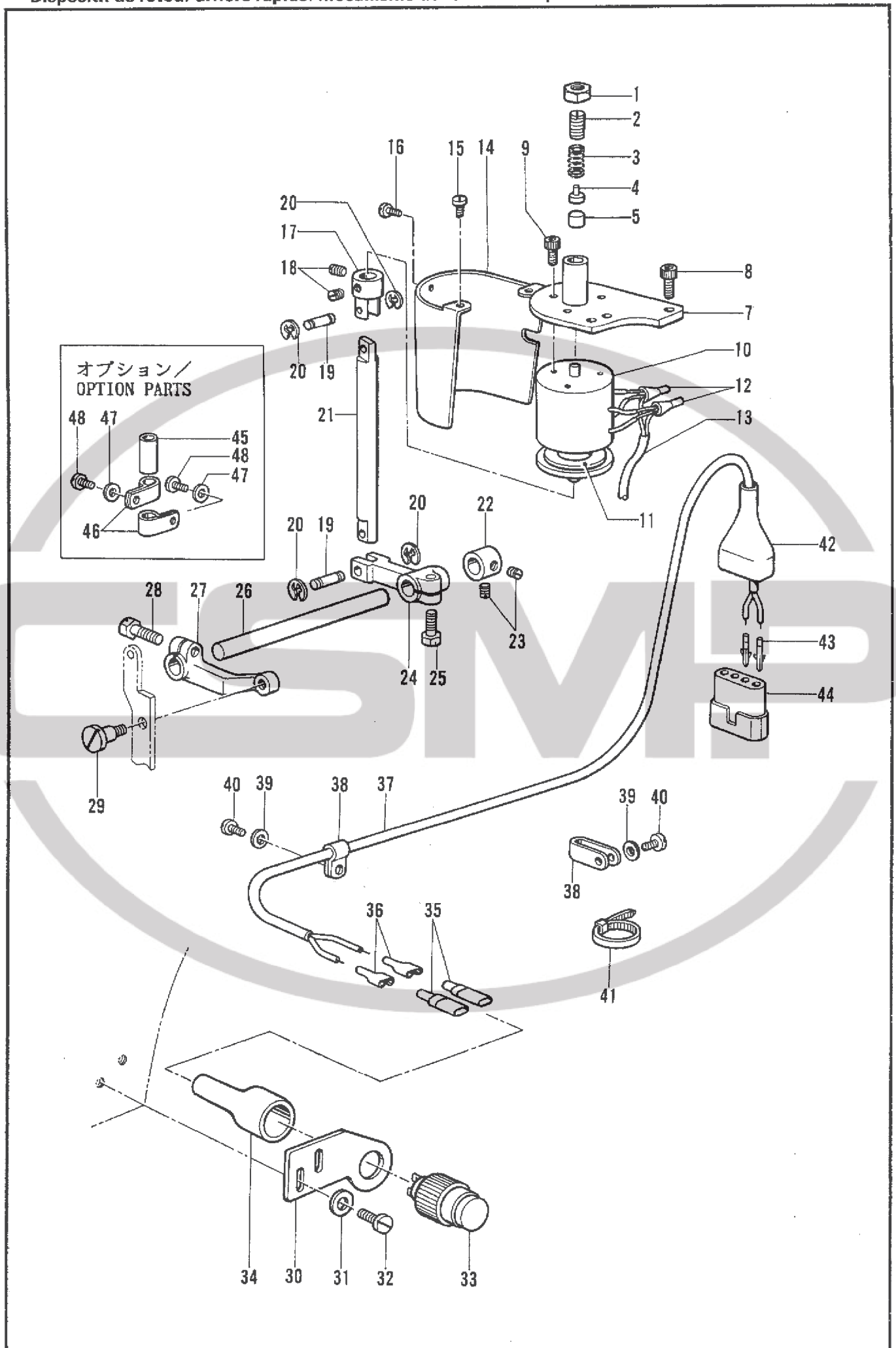

K. タッチバック関係 / Quick back mechanism / Schnellumkehrvorrichtung /
Dispositif de retour arrière rapide / Mecanismo de retroceso rápido

REF.NO.	CODE	Q'TY	ヒンメイ	NAME OF PARTS	RMKS
1	S25900001	1	ナット952-28	NUT 952-28	
2	S29535001	1	チョウセツネジ	ADJUST SCREW	
3	S29534001	1	クッションバネ	CUSHION SPRING	
4	S29536001	1	ピン	PIN	
5	S29537001	1	クッション	CUSHION	
7	S29538001	1	ソレノイド"コティイタクミ	SOLENOID SET PLATE ASSEMBLY	
8	S27001001	3	アナボルト5X12	BOLT 5X12	
9	S27028001	3	アナボルト5X10	BOLT 5X10	
10	S29540001	1	BT.ソレノイド	BT. SOLENOID	
11	S29543001	1	パッキング	PACKING	
12	S29542001	2	ヘイタンセツゾクシ	CONNECTION	
13	S29544001	1	ケーブル	CABLE	
14	S29541001	1	BT.ソレノイド"カハ-	BT. SOLENOID COVER	
15	S25906001	2	シメネジ"357-40X6	SCREW 357X6	
16	S25929001	1	シメネジ"317-44X36	SCREW 317X36	
17	S29545001	1	BT.ソレノイド"ツキ"テ	BT.SOLENOID CONNECTING ROD	
18	S29546001	2	アトメネジ"595-28X8	SET SCREW 595X8	
19	S29548001	2	BT.ツキ"テホ"ウピン	PIN	
20	S25898001	4	トメワ	STOP RING	
21	S29547001	1	BT.ツキ"テホ"ウ	BT.CONNECTING BAR	
22	S26265001	1	カラー	COLLAR	
23	S26039001	2	トメネジ"635-32X5	SET SCREW 635X5	
24	S29549001	1	BT.レンケツB	BT.CONNECTING (B)	
25	S26150001	1	ボルト675-24X16	BOLT 675X16	
26	S29550001	1	BT.レンケツシ"ク	BT. CONNECTING SHAFT	
27	S29551001	1	BT.レンケツA	BT.CONNECTING (A)	
28	S26150001	1	ボルト675-24X16	BOLT 675X16	
29	S26131001	1	タ"ンネジ"675-24X6	STUD SCREW 675X6	
30	S27085001	1	スイッチタ"イ	SWITCH BASE	
31	S26587001	2	サ"ガ"ネ	WASHER	
32	S26357001	2	シメネジ"516-32X14	SCREW 516X14	
33	S27719001	1	Rボ"タンスイッチ	R BUTTON SWITCH	
34	S27086001	1	スイッチカハ-	SWITCH COVER	
35	S27721001	2	ゼ"ツエンスリーブ"	INSULATION SLEEVE	
36	S27720001	2	ア"ッ"チャクタンシ	PRESSURE TERMINAL	
37	S29552001	1	ケーブル	CABLE	
38	S27029001	2	コード"クランプ"	CORD CLAMP	
39	S26999001	2	サ"ガ"ネ3.5	WASHER	
40	S25920001	2	シメネジ"357-40X8	SCREW 357X8	
41	S27052001	1	ケツソクハ"ント"	BAND	
42	S27012001	1	コネクタキャップ4P	CONNECTOR CAP 4P	
43	S27022001	4	コネクタピン4P	CONNECTOR PIN 4P	
44	S27735001	1	コネクタ4P(オス)	CONNECTOR 4P (MALE)	
<オプションパーツ /OPTION PARTS>					
45	S29553001	1	クッション	CUSHION	
46	S27029001	2	コード"クランプ"	CORD CLAMP	
47	S26999001	2	サ"ガ"ネ 3.5	WASHER 3.5	
48	S25920001	2	シメネジ"357-40X8	SCREW 357X8	

L1. 糸調子関係 / Thread tension / Faderspannung /
Tension du fil / Tensión del hilo

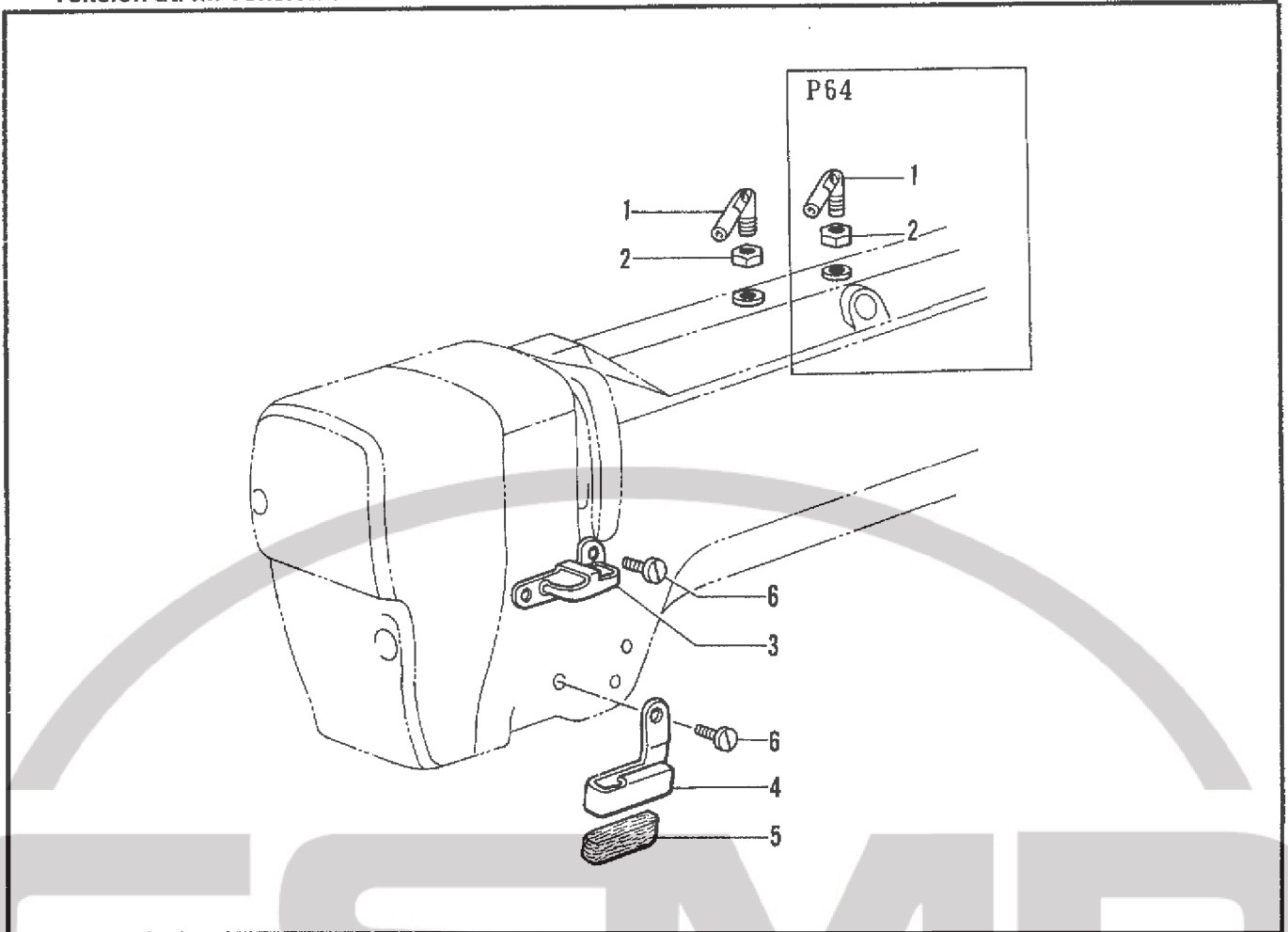

L2. 糸調子関係 / Thread tension / Faderspannung /
Tension du fil / Tensión del hilo

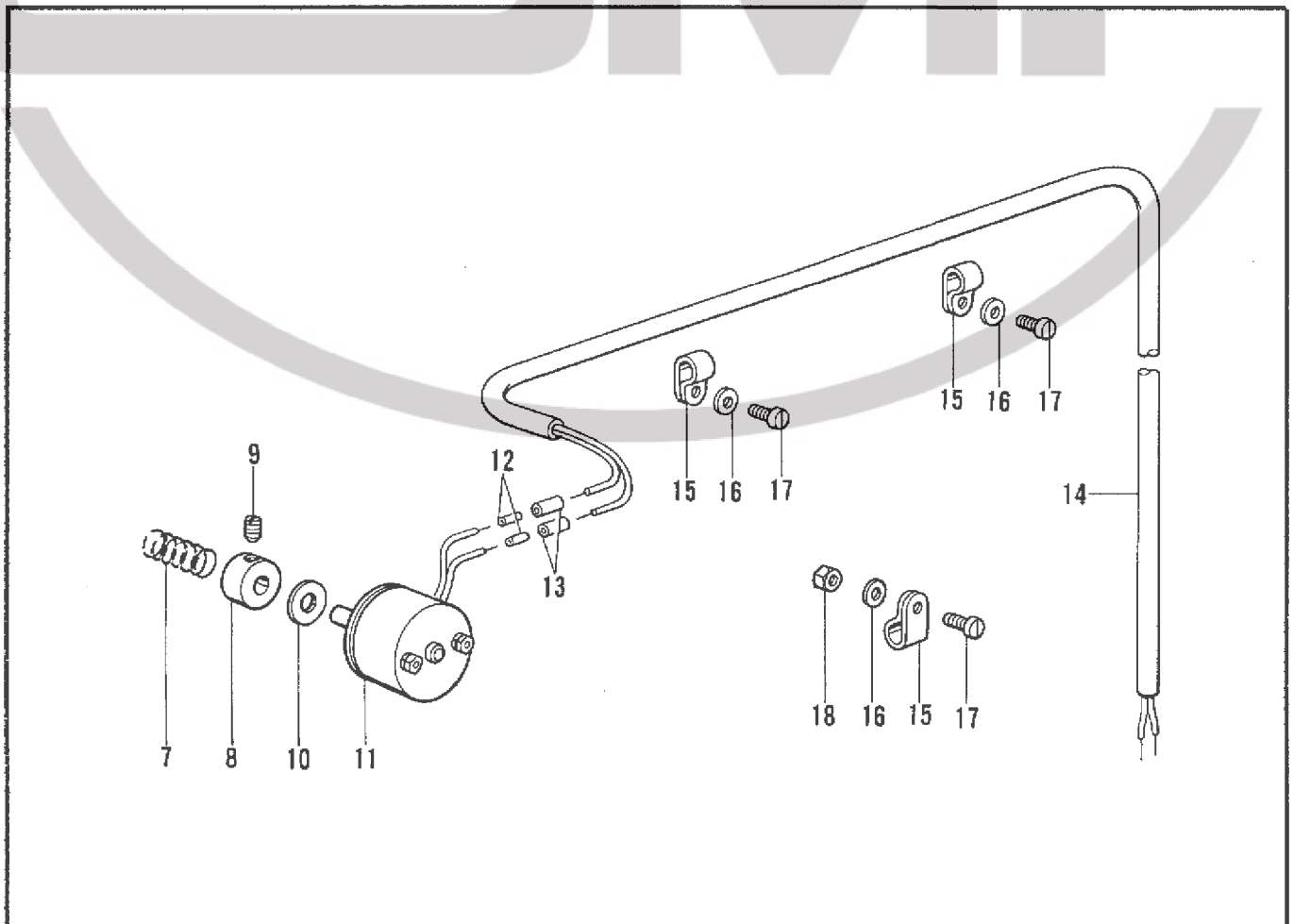

L1. 糸調子関係 / Thread tension / Fadenspannung /
Tension du fil / Tensión del hilo

REF.NO.	CODE	Q'TY	ヒンメイ	NAME OF PARTS	RMKS
<P62>					
1	S26208001	1	ウワイタイトアンナイ	UPPER PLATE THREAD GUIDE	
2	S26460001	1	ナット5.56	NUT 5.56	
<P64>					
1	S26208001	2	ウワイタイトアンナイ	UPPER PLATE THREAD GUIDE	
2	S26460001	2	ナット5.56	NUT 5.56	
3	S29554001	1	アームイトアンナイ	ARM THREAD GUIDE	
4	S26151001	1	アームイトアンナイD	ARM THREAD GUIDE (D)	
5	S26152001	1	アームイトアンナイフェルト	ARM THREAD GUIDE FELT	
6	S26107001	3	サラネジ"340-36X6	SCREW 340X6	

L2. 糸調子関係 / Thread tension / Fadenspannung /
Tension du fil / Tensión del hilo

REF.NO.	CODE	Q'TY	ヒンメイ	NAME OF PARTS	RMKS
7	S26990001	1	コイルバネ	COIL SPRING	
9	S26080001	2	アナトメネジ"318-40X5	SET SCREW 318X5	
12	S26996001	4	アツリヨクスリーブ	PRESSURE SLEEVE	
13	S26997001	4	ゼ"ツエンチューブ"	ISOLATION TUBE	
14	S29555001	1	ケーブル	CABLE	
15	S26998001	3	コード"クランプ"	CORD CLAMP	
16	S26999001	3	サ"カ"ネ3.5	WASHER 3.5	
17	S25920001	2	シメネジ"357-40X8	SCREW 357X8	
18	S25895001	1	ナット4	NUT 4	
19	S25892001	1	サラネジ"4X10	SCREW 4X10	
<P62>					
1	S26208001	1	ウワイタイトアンナイ	UPPER PLATE THREAD GUIDE	
2	S26460001	1	ナット5.56	NUT 5.56	
8	S26989001	1	イトユルメカラー	TENSION RELEASE COLLAR	
10	S26988001	1	イトユルメパッキング"	TENSION RELEASE PACKING	
11	S26987001	1	イトユルメソレノイド"	TENSION RELEASE SOLENOID	
<P64>					
1	S26208001	2	ウワイタイトアンナイ	UPPER PLATE THREAD GUIDE	
2	S26460001	2	ナット5.56	NUT 5.56	
8	S27056001	1	イトユルメカラー	TENSION RELEASE COLALR	
10	S27054001	1	イトユルメパッキング"	TENSION RELEASE PACKING	
11	S27058001	1	イトユルメソレノイド"	TENSION RELEASE SOLENOID	

L3. 糸調子関係 / Thread tension / Faderspannung /
Tension du fil / Tensión del hilo

<P62>

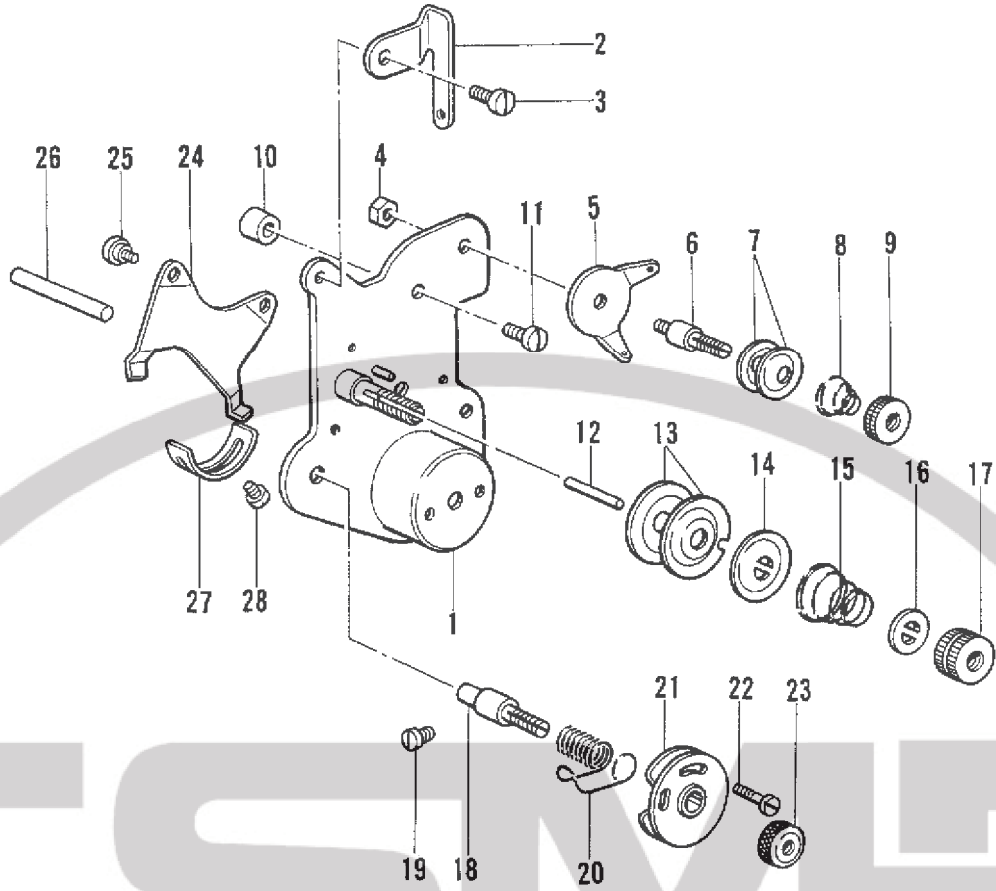

<P64>

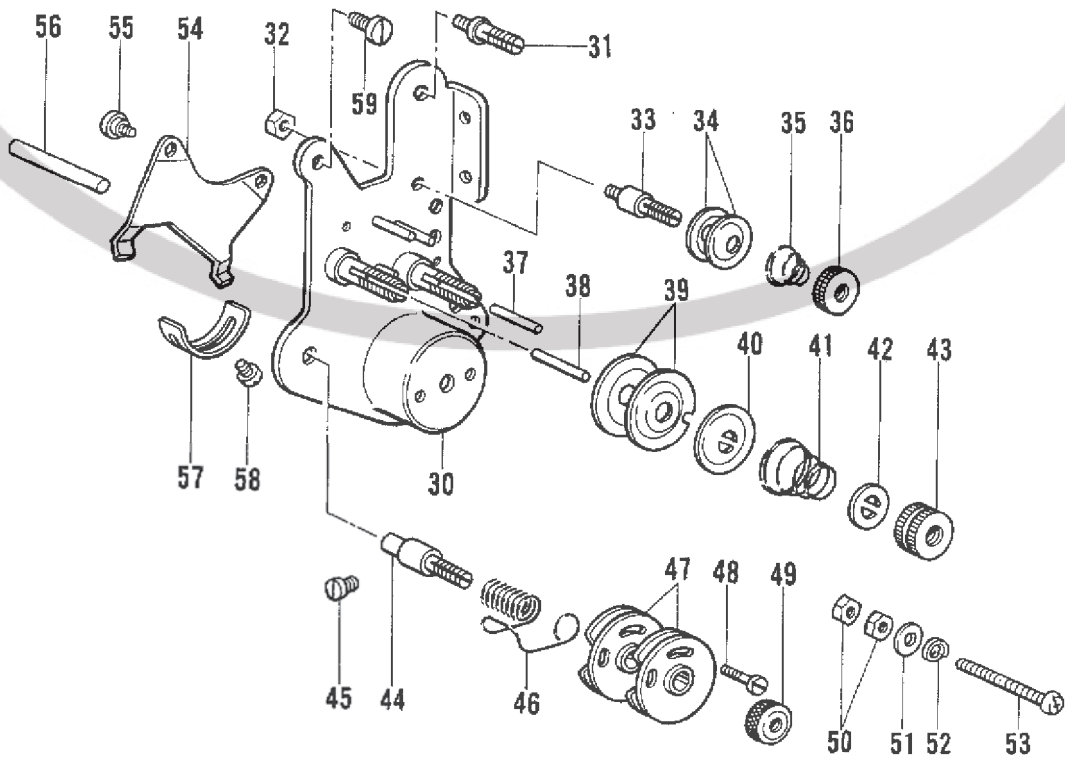

L3. 糸調子関係/Thread tension/Fadertension/
Tension du fil/Tensión del hilo

REF.NO.	CODE	Q'TY	ヒンメイ	NAME OF PARTS	RMKS
< P 62 >					
1	S26922001	1	チョウシタ"イクミ	TENSION BASE ASSEMBLY	
2	S27071001	1	イトカケ	THREAD HOOK	
3	S26554001	1	シメネジ"4.37-32	SCREW 4.37-32	
4	S26088001	1	ナット437-40	NUT 437-40	
5	S27593001	1	プレテンションイタ	PRETENSION PLATE	
6	S26960001	1	チョウシホ"ウ	TENSION STUD	
7	S26961001	2	サ"カ"ネ	WASHER	
8	S26963001	1	チョウシハ"ネS	TENSION SPRING (S)	
9	S26962001	1	チョウシナット	TENSION NUT	
10	S26994001	1	チョウシサラ	TENSION DISC	
11	S26538001	1	シメネジ"357-40X10	SCREW 357X10	
12	S26170001	1	イトユルメピン	PIN	
13	S26110001	2	イトチョウシサラ	TENSION DISC	
14	S26111001	1	チョウシサラオサエ	TENSION DISC PRESSER	
15	S26112001	1	イトチョウシハ"ネ	TENSION SPRING	
16	S26983001	1	カラー	COLLAR	
17	S27341001	1	イトチョウシナット	TENSION NUT	
18	S26169001	1	イトチョウシホ"ウ	TENSION STUD	
19	S25922001	1	シメネジ"357-40X8	SCREW 357X8	
20	S26108001	1	イトトリハ"ネ	SPRING	
21	S26114001	1	イトトリハ"ネアンナイ	SPRING GUIDE	
22	S26115001	1	シメネジ"UNF2-6X6.5	SCREW UNF2-6X6.5	
23	S26116001	1	イトチョウシナット	TENSION NUT	
24	S26991001	1	イトユルメイタ	TENSION RELEASE PLATE	
25	S26102001	2	タ"ンネジ"340-36X2	STUD SCREW 340X2	
26	S26137001	1	イトユルメシ"ク	TENSION RELEASE SHAFT	
27	S26109001	1	イトトリハ"ネストップ"パー	SPRING STOPPER	
28	S26087001	1	シメネジ"340-36X6	SCREW 340X6	
< P 64 >					
30	S29504001	1	チョウシタ"イクミ	TENSION BASE ASSEMBLY	
31	S26992001	1	チョウシホ"ウウエ	TENSION STUD UPPER	
32	S26088001	2	ナット437-40	NUT 437-40	
33	S27057001	1	イトチョウシホ"ウシタ	THREAD TENSION STUD (D)	
34	S26961001	4	チョウシサラ	TENSION DISC	
35	S26963001	2	チョウシハ"ネS	TENSION SPRING (S)	
36	S26962001	2	チョウシナット	TENSION NUT	
37	S26198001	1	イトユルメピンL	PIN (S)	
38	S26204001	1	イトユルメピンS	PIN (L)	
39	S26110001	4	イトチョウシサラ	TENSION DISC	
40	S26111001	2	チョウシサラオサエ	TENSION DISC PRESSER	
41	S26112001	2	イトチョウシハ"ネ	TENSION SPRING	
42	S26983001	2	カラー	COLLAR	
43	S27341001	2	イトチョウシナット	TENSION NUT	
44	S26197001	1	イトチョウシホ"ウL	TENSION STUD (L)	
45	S25922001	1	シメネジ"357-40X8	SCREW 357X8	
46	S26199001	1	イトトリハ"ネ	SPRING	
47	S26114001	2	イトトリハ"ネアンナイ	SPRING GUIDE	
48	S26200001	1	シメネジ"238-80X12	SCREW 238X12	
49	S26116001	1	イトチョウシナット	TENSION NUT	
50	S27066001	2	ナット4	NUT 4	
51	S27068001	1	ハ"ネサ"カ"ネ4	SPRING WASHER 4	
52	S27067001	1	サ"カ"ネ4	WASHER 4	
53	S27065001	1	シメネジ"	SCREW	
54	S27055001	1	イトユルメイタ	TENSION RELEASE PLATE	
55	S26102001	2	タ"ンネジ"340-36X2	STUD SCREW 340X2	
56	S26137001	1	イトユルメシ"ク	TENSION RELEASE SHAFT	
57	S26109001	1	イトトリハ"ネストップ"パー	SPRING STOPPER	
58	S26067001	1	シメネジ"340-36X6	SCREW 340X6	
59	S29768001	1	シメネジ"435-32X6.5	SCREW 435X6.5	

M1. 糸切り関係/Thread trimmer mechanism/Fadenabschneidevorrichtung/
 Mécanisme de coupe-fil/Mecanismo de la cortadura de hilos

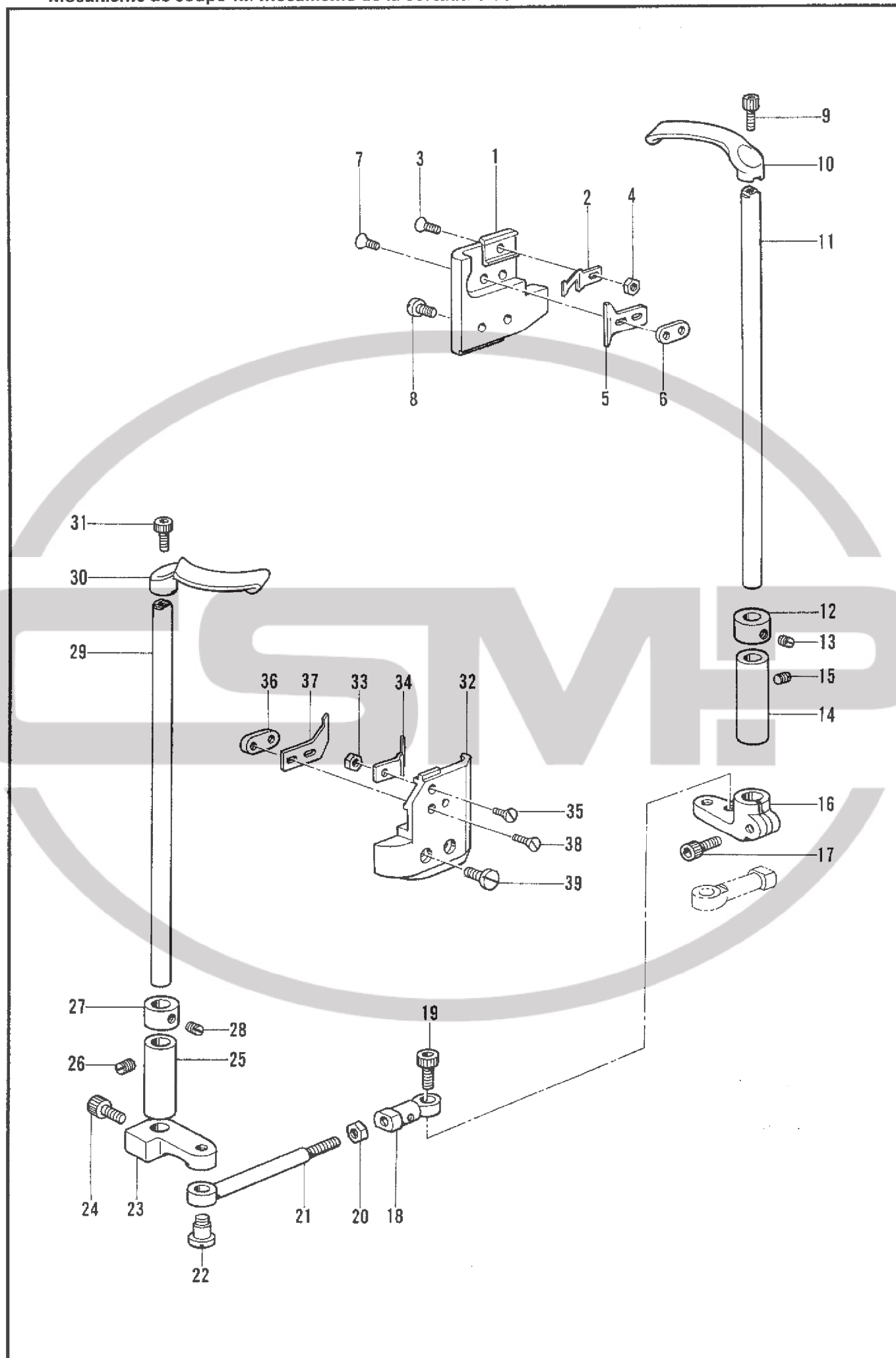

M1. 糸切り関係/Thread trimmer mechanism/Fadenabschneidevorrichtung/
Mécanisme de coupe-fil/Mecanismo de la cortadura de hilos

REF.NO.	CODE	Q'TY	品名	NAME OF PARTS	RMKS
1	S29556001	1	コティハウケ	FIXED KNIFE HOLDER	
2	S29277001	1	イトオサエハネ	SPRING	
3	S29265001	1	サラネジ"3X3.3	SCREW 3X3.3	
4	S29264001	1	ナット3	NUT 3	
5	S29275001	1	コティハ	FIXED KNIFE	
6	S29557001	1	コティハトメイタ	KNIFE STOPPER PLATE	
7	S29276001	2	サラネジ"318-44X6	SCREW 318X6	
8	S26534001	2	シメネジ"357-40X6	SCREW 357X6	
9	S27003001	1	アナボ"ルト4X8	BOLT 4X8	
10	S29274001	1	イト"ウハ	MOVABLE KNIFE	
11	S29558001	1	メスジ"ク	KNIFE SHAFT	
12	S27528001	1	セットカラー	SET COLLAR	
13	S26934001	2	トメネジ"5X5	SET SCREW 5X5	
14	S29559001	1	メスジ"クメタル	KNIFE SHAFT BUSH	
15	S25927001	1	トメネジ"4.37	SET SCREW 4.37	
16	S29560001	1	メスジ"クタ"ルマ	KNIFE SHAFT CRANK	
17	S26935001	1	アナボ"ルト5X14	BOLT 5X14	
<P64>					
18	S27743001	1	ツキ"テ	JOINT	
19	S26935001	1	アナボ"ルト5X14	BOLT 5X14	
20	S25894001	1	ナット5	NUT 5	
21	S29561001	1	メスジ"クレンケツル	KNIFE SHAFT CONNECTING (L)	
22	S27564001	1	タ"ンネジ"M5	STUD SCREW M5	
23	S27562001	1	イト"ウハレバ"ーL	MOVABLE LEVER (L)	
24	S26935001	1	アナボ"ルト5X14	BOLT 5X14	
25	S29559001	1	メスジ"クメタル	KNIFE SHAFT BUSH	
26	S25927001	1	トメネジ"4.37	SET SCREW 4.37	
27	S27528001	1	セットカラー	SET COLLAR	
28	S26934001	2	トメネジ"5X5	SET SCREW 5X5	
29	S29558001	1	メスジ"ク	KNIFE SHAFT	
30	S29274001	1	イト"ウハ	MOVABLE KNIFE	
31	S27003001	1	アナボ"ルト4X8	BOLT 4X8	
32	S29562001	1	コティハウケ	FIXED KNIFE HOLDER	
33	S29264001	1	ナット	NUT	
34	S29277001	1	イトオサエハネ	SPRING	
35	S29265001	1	サラネジ"3X3.3	SCREW 3X3.3	
36	S29557001	1	コティハトメイタ	KNIFE STOPPER PLATE	
37	S29275001	1	コティハ	FIXED KNIFE	
38	S29276001	2	サラネジ"318-44X6	SCREW 318X6	
39	S26534001	2	シメネジ"357-40X6	SCREW 357X6	

M2. 糸切り関係 / Thread trimmer mechanism / Fadenabschneidevorrichtung /
 Mécanisme de coupe-fil / Mecanismo de la cortadura de hilos

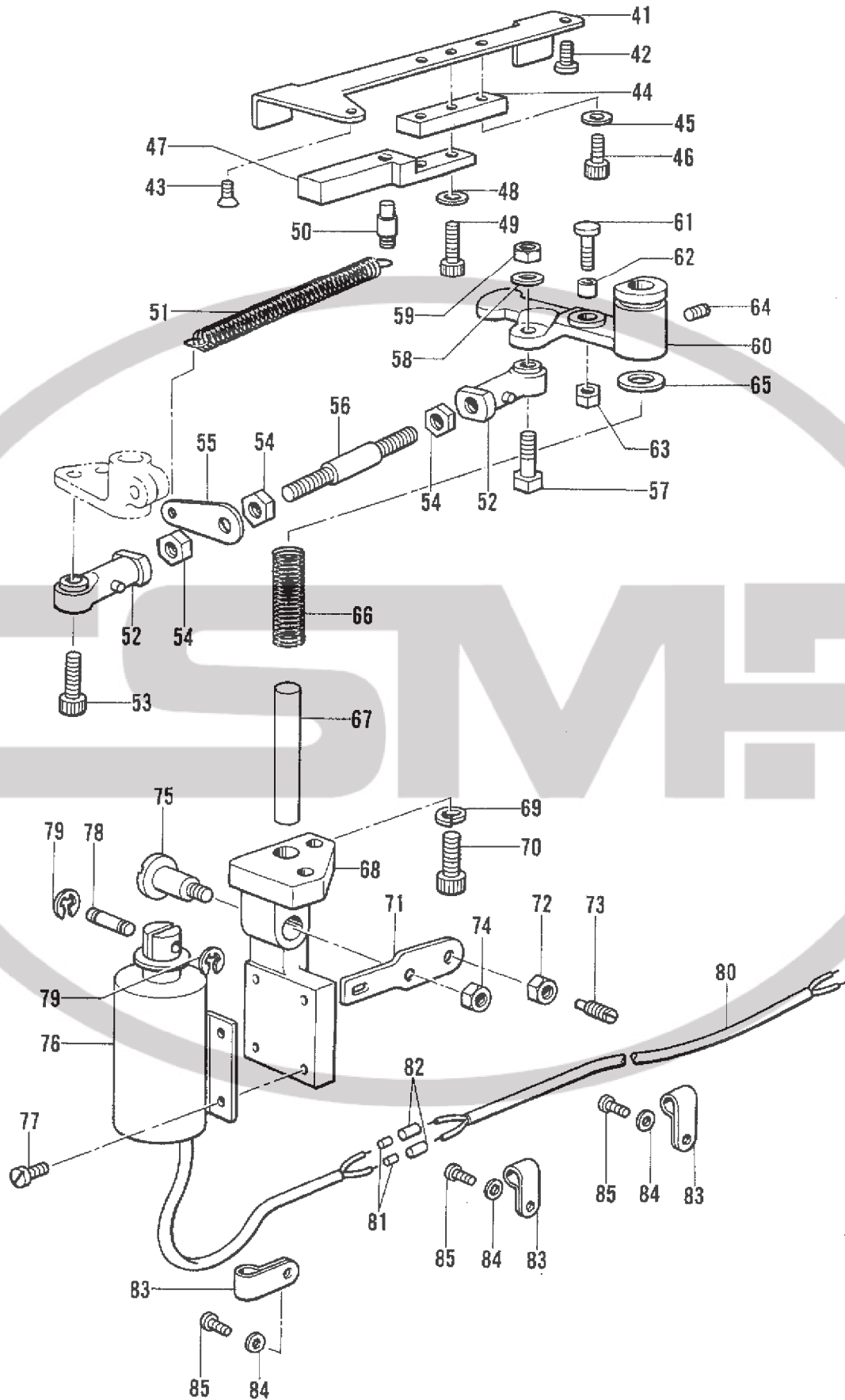

M2. 糸切り関係 / Thread trimmer mechanism / Fadenabschneidevorrichtung /
 Mécanisme de coupe-fil / Mecanismo de la cortadura de hilos

REF.NO.	CODE	Q'TY	ヒンメイ	NAME OF PARTS	RMKS
41	S29568001	1	クト"ウレハ"-ウケイタ	DRIVING LEVER HOLDER PLATE	
42	S26358001	1	シメネジ"516-32X14	SCREW 516X14	
43	S29565001	1	サラネジ"516-32X9	SCREW 516X9	
44	S29569001	1	クト"ウレハ"-ストッパ"	DRIVING LEVER STOPPER	
45	S29567001	1	サ"ガ"ネ5	WASHER 5	
46	S26972001	1	アナボ"ルト5X20	BOLT 5X20	
47	S29570001	1	クト"ウレハ"-ガイ"イト"	DRIVING LEVER GUIDE	
48	S29567001	2	サ"ガ"ネ5	WASHER 5	
49	S29566001	2	アナボ"ルト5X25	BOLT 5X25	
50	S29563001	1	ハ"ネカケ	SPRING HOOK	
51	S29570001	1	クト"ウレハ"-ハ"ネ	SPRING	
52	S27743001	2	ツキ"テ	JOINT	
53	S27001001	1	アナボ"ルト5X12	BOLT 5X12	
54	S25894001	3	ナット5	NUT 5	
55	S27524001	1	ハ"ネカケ	SPRING HOOK	
56	S29571001	1	レンケツジ"ク	CONNECTING SHAFT	
57	S27744001	1	ジ"ョイントネジ"	JOINT SCREW	
58	S27745001	1	ハ"ネサ"ガ"ネ5	SPRING WASHER 5	
59	S25893001	1	ナット5	NUT 5	
60	S29572001	1	クト"ウレハ"-	DRIVING LEVER	
61	S27596001	1	レハ"-コロタ"ンネジ"	STUD SCREW	
62	S25940001	1	ローラ-コロ	ROLLER	
63	S27727001	1	ナット476-32	NUT 476-32	
64	S26272001	1	トメネジ"556-32X5	SET SCREW 556X5	
65	S27597001	1	カンショウゴム	CHUSION RUBBER	
66	S27524001	1	ハ"ネカケ	SPRING HOOK	
67	S29573001	1	クト"ウレハ"-シ"ク	DRIVING LEVER SHAFT	
68	S29574001	1	ソレノイト"ト"タイ	SOLENOID BASE	
69	S29564001	2	ハ"ネサ"ガ"ネ	SPRING WASHER	
70	S29575001	2	アナボ"ルト6X2.2	BOLT 6X2.2	
71	S29576001	1	ソレノイト"レハ"-	SOLENOID LEVER	
72	S27734001	2	ナット5.95	NUT 5.95	
73	S27598001	1	ピンネジ"	PIN SCREW	
74	S26459001	1	ナット5.56	NUT 5.56	
75	S27002001	1	タ"ンネジ"	STUD SCREW	
76	S27004001	1	ソレノイト"	SOLENOID	
77	S27007001	4	シメネジ"3X6	SCREW 3X6	
78	S27006001	1	プ"ランジ"ャ-ピン	PPLUNGER PIN	
79	S27008001	2	トメワE2.5	STOP RING E2.5	
80	S29577001	1	ケー"ブル	CABLE	
81	S26996001	2	アツリヨクスリーブ"	PRESSURE SLEEVE	
82	S26997001	2	ゼ"ツエンチューブ"	ISOLATION TUBE	
83	S26998001	3	コー"ト"クランプ"	CORD CLAMP	
84	S26999001	3	サ"ガ"ネ3.5	WASHER 3.5	
85	S25920001	3	シメネジ"357-40X8	SCREW 357X8	

N. 糸切り・タッチバック関係 / Thread trimmer and quick back mechanism / Fadenabschneider und Schnellumkehrvorrichtung / Mécanisme de coupe-fil et retour arrière rapide / Mecanismo de la cortadura de hilos y retroceso rápido

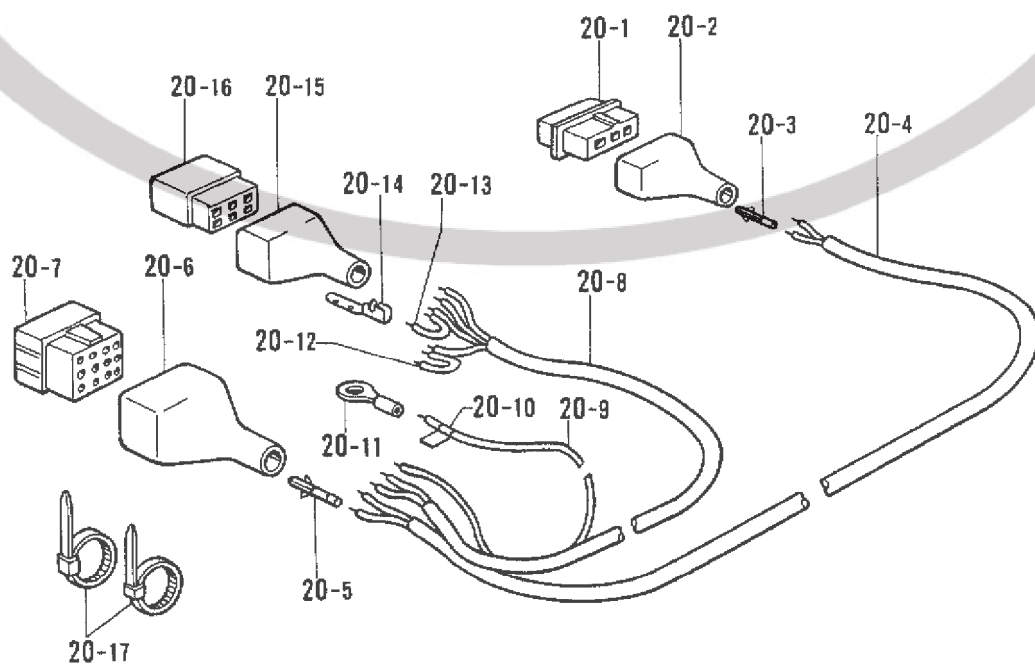
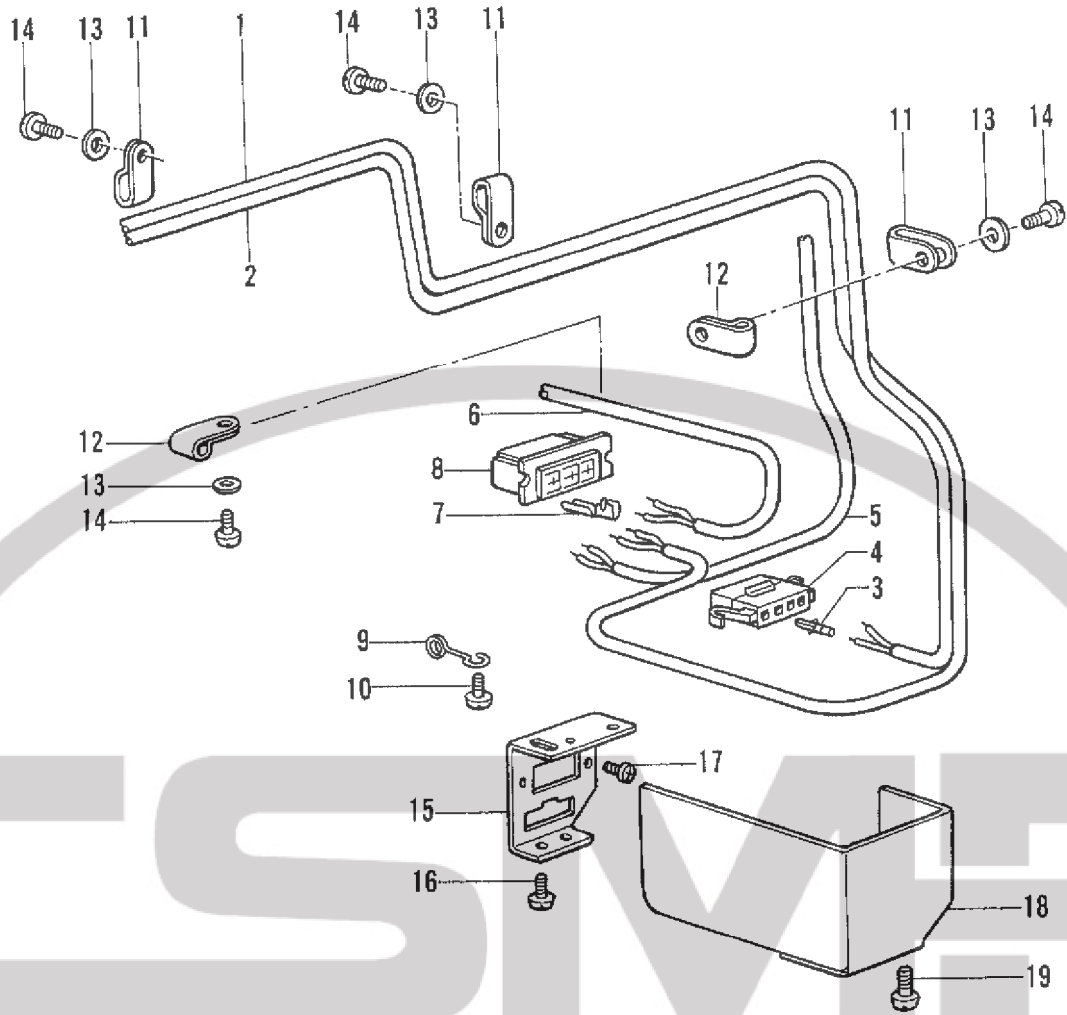

N. 糸切り・タッチバック関係 / Thread trimmer and quick back mechanism / Fadenabschneider und Schnellumkehrvorrichtung / Mécanisme de coupe-fil et retour arrière rapide / Mecanismo de la cortadura de hilos y retroceso rápido

REF.NO.	CODE	Q'TY	品名	NAME OF PARTS	RMKS
1	S29552001	1	ケーブル	CABLE	
2	S29555001	1	ケーブル	CABLE	
3	S29578001	2	コネクタピン4P(メス)	CONNECTOR PIN 4P (FEMALE)	
4	S29579001	1	コネクタ4P(オス)	CONNECTOR 4P	
5	S29544001	1	ケーブル	CABLE	
6	S29577001	1	ケーブル	CABLE	
7	S29580001	2	コネクタピン6P(メス)	CONNECTOR PIN 6P (FEMALE)	
8	S29581001	1	コネクタ6P(オス)	CONNECTOR 6P (MALE)	
9	S29582001	1	ケーブルオサエ	CABLE HOLDER	
10	S25906001	1	シメネジ"357-40X6	SCREW 357X6	
11	S27029001	3	コード"クランプ	CORD CLAMP	
12	S26998001	2	コード"クランプ	CORD CLAMP	
13	S26999001	4	ワッシャー3.5	WASHER 3.5	
14	S25920001	4	シメネジ"357-40X8	SCREW 357X8	
15	S29583001	1	コネクタートリツケイタ	CONNECTOR SET PLATE	
16	S25920001	2	シメネジ"357-40X8	SCREW 357X8	
17	S27007001	2	シメネジ"3X6	SCREW 3X6	
18	S29584001	1	コネクタカバー	CONNECTOR COVER	
19	S27007001	2	シメネジ"3X6	SCREW 3X6	
20	S29585001	1	ケーブルクミ	CABLE ASSEMBLY	
20-1	S29586001	1	コネクタ4P(メス)	CONNECTOR 4P (FEMALE)	
20-2	S29587001	1	4Pゴムカバー-B	4P RUBBER COVER (B)	
20-3	S29588001	2	コネクタピン(オス)	CONNECTOR PIN (MALE)	
20-4	S29589001	1	ケーブル	CABLE	
20-5	S27022001	6	コネクタピン(オス)	CONNECTOR PIN (MALE)	
20-6	S29590001	1	コネクタカバー12P	CONNECTOR COVER 12P	
20-7	S29591001	1	コネクタ12P	CONNECTOR 12P	
20-8	S27011001	1	ケーブル	CABLE	
20-9	S29592001	1	アースせん	EARTH WIRE	
20-10	S27709001	1	ワイヤーマーク	WIRE MARK	
20-11	S27030001	1	アツチャクタンシ	INSULATION SLEEVE	
20-12	S29593001	1	ケーブル	CABLE	
20-13	S29594001	1	ケーブル	CABLE	
20-14	S29595001	6	コネクタピン6P(オス)	CONNECTOR PIN 6P (MALE)	
20-15	S27014001	1	ゴムカバー6P(B)	RUBBER COVER 6P (B)	
20-16	S29596001	1	コネクタ6P(メス)	CONNECTOR 6P (FEMALE)	
20-17	S27052001	1	ケツソクバンド	BAND	

P. ベルトカバー関係 (オプション) / Belt cover mechanism (Option parts) / Gurtabdeckung (Sonderzubehör) /
 Couvre-courroie (Pièces en option) / Cubierta de correa (Piezas opcionales)

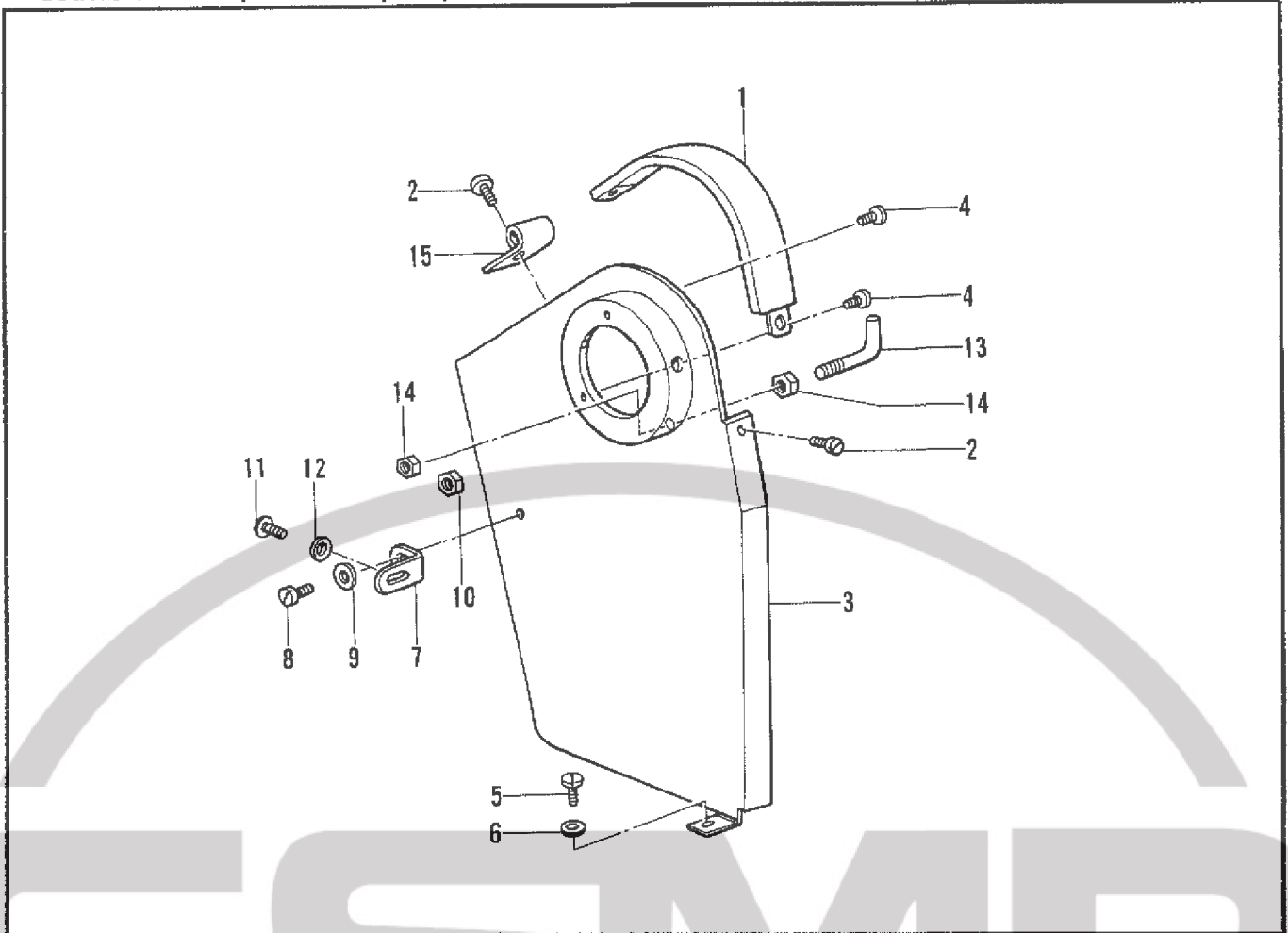

Z1. 付属品関係 / Accessories/Zubehör/
 Accessories/Accesorios

<-700>

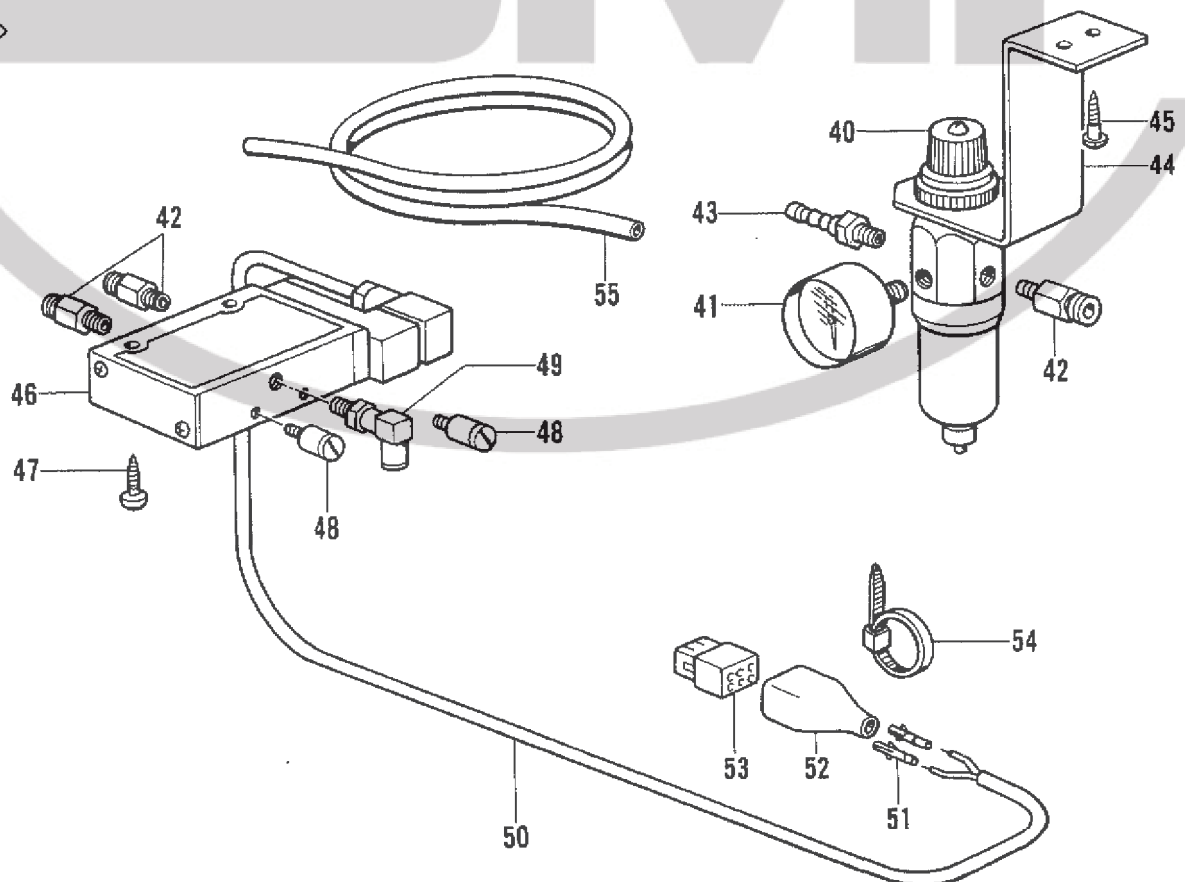

◎ 付属品の明細は変更することがあります。

◎ The details of included accessories are subject to change.

◎ Änderungen in der Aufstellung der Mitgelieferten Zubehöre sind vorbehalten.

◎ Les détails des accessoires inclus sont sujets à des changements.

◎ Los detalles de los accesorios incluidos pueden variar.

P. ベルトカバー関係 (オプション) / Belt cover mechanism (Option parts) / Gurtabdeckung (Sonderzubehör) /
Couvre-courroie (Pièces en option) / Cubierta de correa (Piezas opcionales)

REF.NO.	CODE	Q'TY	品名	NAME OF PARTS	RMKS
1	S27016001	1	ベルトカバー-U	BELT COVER (U)	
2	S26358001	2	シメネジ"516-32X14	SCREW 516X14	
3	S29301001	1	ベルトカバー	BELT COVER	
4	S26224001	2	シメネジ"340-36X5	SCREW 340X5	
5	S26087001	1	シメネジ"340-36X6	SCREW 340X6	
6	S26220001	1	ワッシャー	WASHER	
7	S26354001	1	ベルトカバー"トメカナグ"	BELT COVER STOPPER	
8	S26534001	1	シメネジ"476-40X6	SCREW 476X6	
9	S26587001	1	ワッシャー	WASHER	
10	S27727001	1	ナット476-32	NUT 476-32	
11	S26035001	1	シメネジ"437-32X6	SCREW 437X6	
12	S26220001	1	ワッシャー	WASHER	
13	S29302001	1	ケンシュツキササエ	SYNCHRONIZER SUPPORT	
14	S27734001	2	ナット6	NUT 6	
15	S29620001	1	コード"クランプ"	CORD CLAMP	

Z1. 付属品関係 / Accessories / Zubehör /
Accessories / Accesorios

REF.NO.	CODE	Q'TY	品名	NAME OF PARTS	RMKS
<-700>					
40	S27040001	1	エア-リキ"ユレター	REGULATOR	
41	S27044001	1	アツリョクゲイ	PRESSURE GAUGE	
42	S27740001	3	ニップル	NIPRE	
43	S27048001	1	ホースニップル	HOSE NIPRE	
44	147733001	1	エア-ユニットトリツケイタ	AIR UNIT SET PLATE	
45	101118001	2	マルモクネジ"4.5X20	SCREW 4.5X20	
46	S27037001	1	ソレノイド"ハ"ルブ"	SOLENOID VALVE	
47	S26949001	2	モクネジ"4.5	SCREW 4.5	
48	S26948001	2	サイレンサー	SILENCER	
49	S27741001	1	エルボ"	ELBOW	
50	S27050001	1	ケーブル	CABLE	
51	S27022001	2	コネクタピン"オス	CONNECTOR PIN (MALE)	
52	S29250001	1	コネクタ"キャップ"6P	CONNECTOR CAP 6P	
53	S29249001	1	コネクタ"メス"6P	CONNECTOR 6P (FEMALE)	
54	S27052001	1	ゲツソク"バンド"	BAND	
55	S29608001	1	エア-チューブ"	AIR TUBE	

Z2. 付属品関係/Accessories/Zubehör/
Accessories/Accessorios

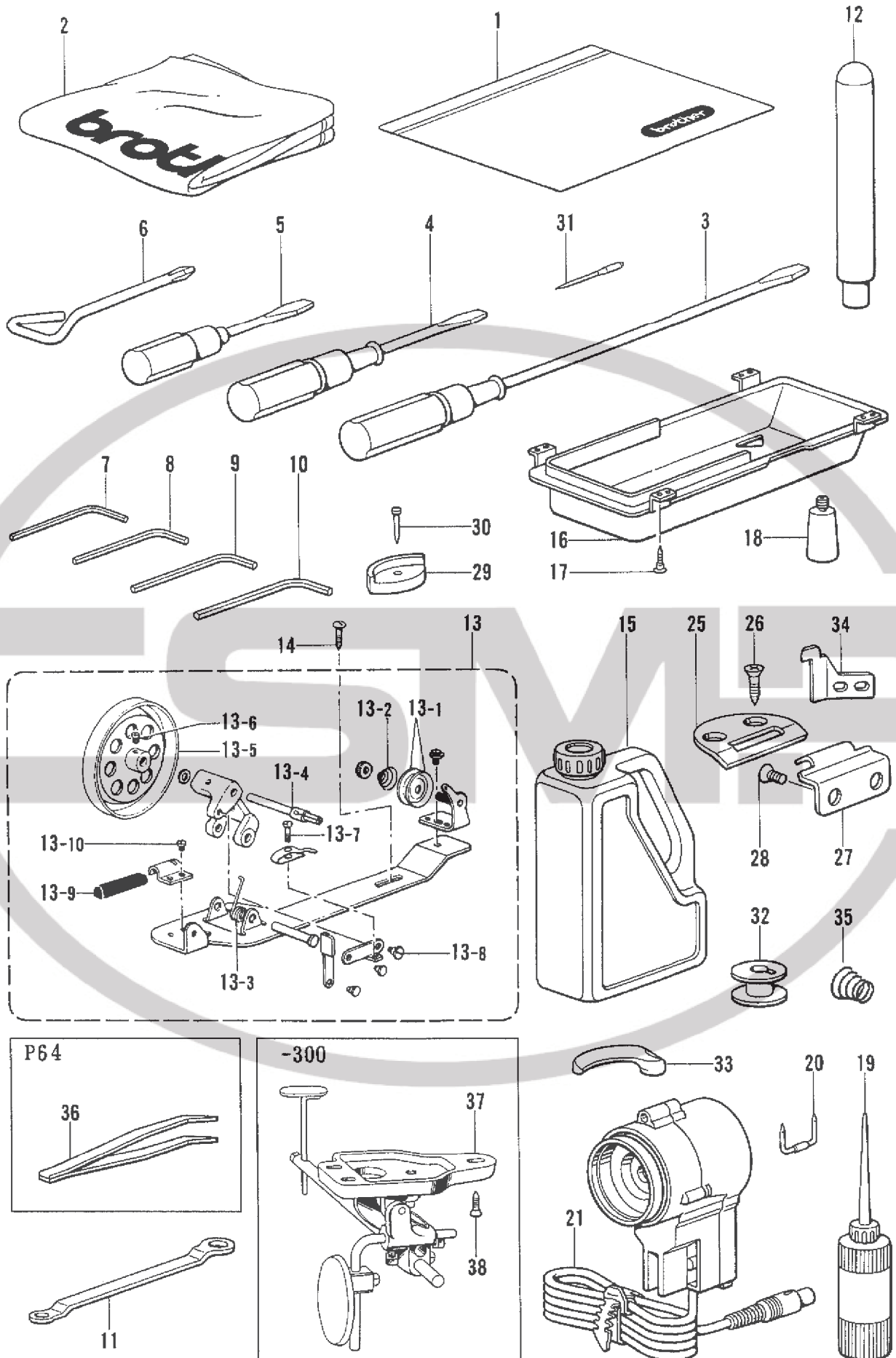

◎ 付属品の明細は変更することがあります。

◎ The details of included accessories are subject to change.

◎ Änderungen in der Aufstellung der Mitgelieferten Zubehöre sind vorbehalten.

◎ Les détails des accessoires inclus sont sujets à des changements.

◎ Los detalles de los accesorios incluidos pueden variar.

22. 付属品関係/Accessories/Zubehör/
Accessories/Accessorios

REF.NO.	CODE	Q'TY	ヒンメイ	NAME OF PARTS	RMKS
1	122991001	1	フソクヒンホ ^o リフクロ	ACCESSORY BAG	
2	144222001	1	-----	HEAD COVER	
3	S25931001	1	ト ^o ライハ ^o ー	DRIVER	
4	S25932001	1	ト ^o ライハ ^o ー	DRIVER	
5	S25933001	1	ト ^o ライハ ^o ー	DRIVER	
6	S25943001	1	+ト ^o ライハ ^o ー	DRIVER	
7	S26148001	1	6カクホ ^o ウスハ ^o ナ1.6	HEXAGONAL WRENCH 1.6	
8	S26280001	1	6カクホ ^o ウスハ ^o ナ2.5	HEXAGONAL WRENCH 2.5	
9	S26576001	1	6カクホ ^o ウスハ ^o ナ3	HEXAGONAL WRENCH 3	
10	S26575001	1	6カクホ ^o ウスハ ^o ナ4	HEXAGONAL WRENCH 4	
11	S26149001	1	メガ ^o ネレンチ	WRENCH	
12	S26536001	1	トウフ ^o ササエマクラ	HEAD REST	
13	117963110	1	イトマキキクミ	BOBBIN WINDER ASSEMBLY	
13-1	145446001	2	イトチョウシサラ	TENSION DISC	
13-2	100401001	1	イトチョウシハ ^o ネ	TENSION SPRING	
13-3	117969001	1	イトマキシ ^o クウケカエリハ ^o ネ	SPRING	
13-4	117970001	1	イトマキシ ^o ク	BOBBIN WINDER SHAFT	
13-5	S18634001	1	イトマキクルマ	BOBBIN WINDER WHEEL	
13-6	100366002	1	マルヒラトメネシ ^o 4.37X5	SCREW 4.37X5	
13-7	100657001	1	シメネシ ^o 3.18	SCREW 3.18	
13-8	100659001	1	タ ^o ンネシ ^o 3.18	SCREW 3.18	
13-9	100662001	1	イトマキクルマカイトント ^o メ	BOBBIN WINDER WHEEL STOPPER	
13-10	S01297001	1	シメネシ ^o 3.57	SCREW 3.57	
14	100666002	2	マルモクネシ ^o 5.5X20	SCREW 5.5X20	
15	154702001	1	オイルタンク	OIL TANK	
16	S29306001	1	オイルハ ^o ン	OIL PAN	
17	S25564001	8	クキ ^o	NAIL	
18	S29307001	1	ホ ^o リオイル ^o ータイ	OILER	
19	S25936001	1	ホ ^o リオイル ^o ー	OILER	
20	S27024001	5	ステップル	STAPLE	
21	J00670001	1	シンクロナイサ ^o ー	SYNCHRONIZER	
25	S26228001	2	ヒンジ ^o ウケ	HINGE BRACKET	
26	S25903001	4	サラモク52X25	SCREW 52X25	
27	S26225001	2	ヒンジ ^o	HINGE	
28	S26227001	4	ヒンジ ^o ネシ ^o	HINGE SCREW	
29	S26261001	4	トウフ ^o シキゴ ^o ム	HEAD CUSHION	
30	S25904001	4	クキ ^o	NAIL	
<P62>					
31	S25947016	3	ミシンハリDPX17#16	NEEDLE DPX17#16	
32	S29266001	6	ホ ^o ヒ ^o ン	BOBBIN	
33	S29274001	1	イト ^o ウハ	MOVABLE KNIFE	
34	S29275001	1	コテイハ	FIXED KNIFE	
35	S26993001	1	チョウシハ ^o ネ	SPRING	
<P64>					
31	S25947016	6	ミシンハリDPX17#16	NEEDLE DPX17#16	
32	S29266001	12	ホ ^o ヒ ^o ン	BOBBIN	
33	S29274001	2	イト ^o ウハ	MOVABLE KNIFE	
34	S29275001	2	コテイハ	FIXED KNIFE	
35	S26993001	2	チョウシハ ^o ネ	SPRING	
36	S26233001	1	ヒ ^o ンセット	TWEEZERS	
<-300>					
37	S29308001	1	ヒサ ^o アケ ^o セット	KNEE LIFTER SET	
38	S25903001	3	サラモク52X25	SCREW 52X25	

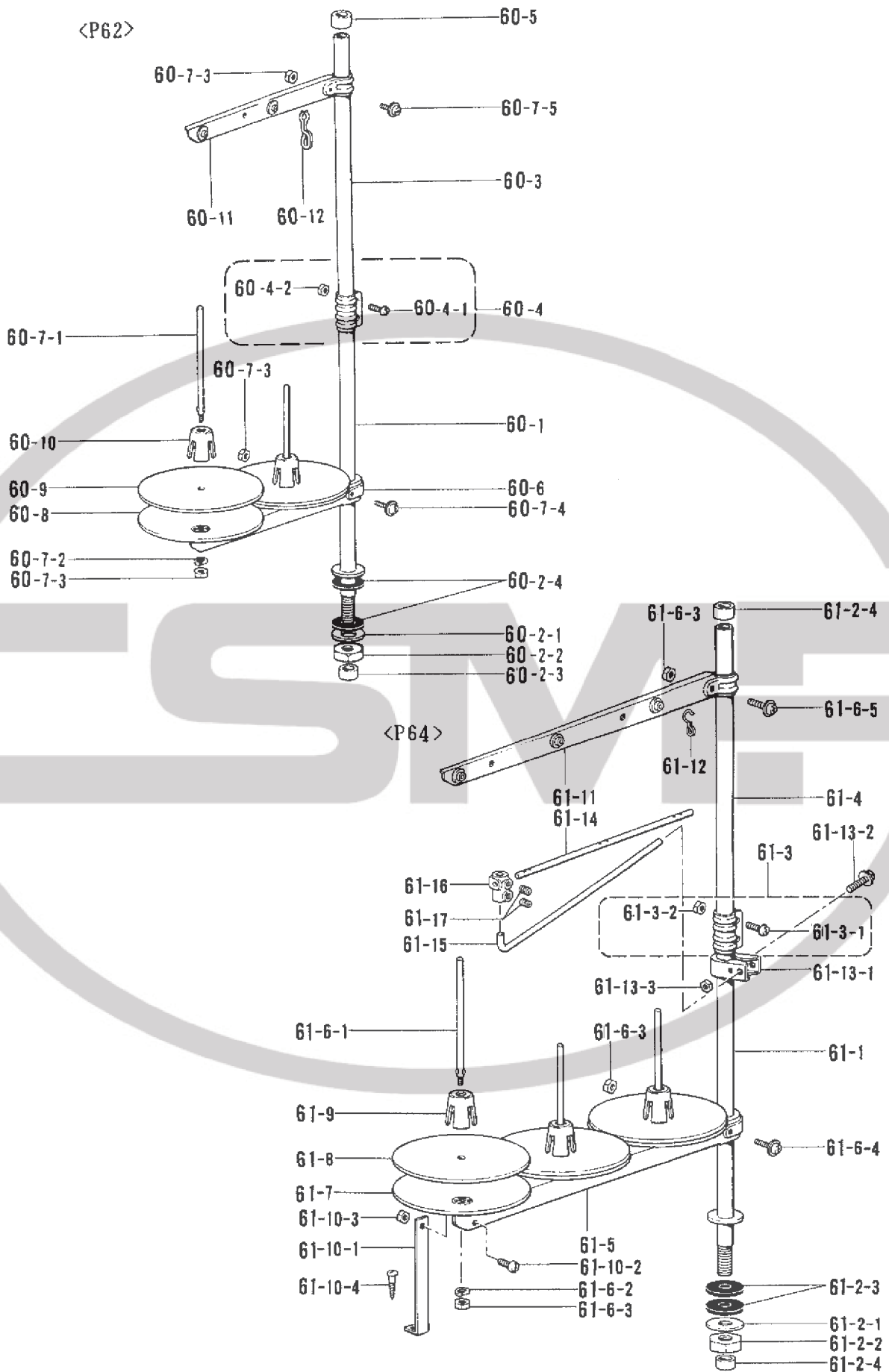

◎ 付属品の明細は変更することがあります。

◎ The details of included accessories are subject to change.

◎ Änderungen in der Aufstellung der Mitgelieferten Zubehöre sind vorbehalten.

◎ Les détails des accessoires inclus sont sujets à des changements.

◎ Los detalles de los accesorios incluidos pueden variar.

23. 付属品関係/Accessories/Zubehör/
Accessories/Accessorios

REF.NO.	CODE	Q'TY	ヒンメイ	NAME OF PARTS	RMKS
<P62>					
60	S02763202	1	イトタテタ"イクミ2DR	COTTON STAND ASSEMBLY (2DR)	
60-1	156112003	1	コラムパイプ	COLUMN PIPE (D)	
60-2	S02777001	1	パイプDネジ"セットB	PIPE (D) SCREW SET (B)	
60-2-1	150206002	1	ヒラサ"ガ"ネ16	PLAIN WASHER 16	
60-2-2	150191002	1	6カクナット5/8	NUT 5/8	
60-2-3	150174000	1	コラムキャップ	COLUMN CAP	
60-2-4	S01005000	2	イトタテゴム	RUBBER WASHER	
60-3	150172003	1	コラムパイプ	COLUMN PIPE	
60-4	150106003	1	コラムジョイントクミ	COLUMN JOINT ASSEMBLY	
60-4-1	062501406	2	ナヘ"コ5X14	SCREW 5X14	
60-4-2	021500106	2	1シュナット5	NUT 5	
60-5	150174000	1	コラムキャップ	COLUMN CAP	
60-6	S02778002	1	スプールホルダー-2	SPOOL HOLDER 2	
60-7	S02780001	1	スプールネジ"セット2	SPOOL SCREW SET 2	
60-7-1	150179002	2	スプールシャフトB	SPOOL SHAFT (B)	
60-7-2	028050246	2	ハ"ネサ"ガ"ネ2-5	SPRING WASHER 2-5	
60-7-3	021500106	4	1シュナット5	NUT 5	
60-7-4	050503006	1	ナヘ"コヒラサ"5X30	WASHER SCREW 5X30	
60-7-5	050501406	1	ナヘ"コヒラサ"5X14	WASHER SCREW 5X14	
60-8	150180001	2	ウケサ"ラ	SPOOL STAND BASE	
60-9	150182000	2	スプールマット	SPOOL MAT	
60-10	126863001	2	スプールクッション	SPOOL CUSHION	
60-11	S02786002	1	スレット"ハンガ"ークミ2	THREAD HANGER ASSEMBLY 2	
60-12	S02747101	1	イトカケハ"ネ	SPRING	
<P64>					
61	S07558009	1	イトタテタ"イクミ3DRTHF	COTTON STAND ASSEMBLY (3DRTHF)	
61-1	156112003	1	コラムパイプD	COLUMN PIPE (D)	
61-2	S02777001	1	パイプDネジ"セットB	PIPE (D) SCREW SET (A)	
61-2-1	150206002	1	ヒラサ"ガ"ネ16	PLAIN WASHER 16	
61-2-2	150191002	1	6カクナット5/8	NUT 5/8	
61-2-3	S01005000	2	イトタテゴム	RUBBER WASHER	
61-2-4	150174000	2	コラムキャップ	COLUMN CAP	
61-3	150106003	1	コラムジョイントクミ	COLUMN JOINT ASSEMBLY	
61-3-1	062501406	2	ナヘ"コ5X14	SCREW 5X14	
61-3-2	021500106	2	1シュナット5	NUT 5	
61-4	150172003	1	コラムパイプ	COLUMN PIPE	
61-5	S02779009	1	スプールホルダー-3	SPOOL HOLDER 3	
61-6	S02782001	1	スプールネジ"セット3	SPOOL SCREW SET 3	
61-6-1	150179002	3	スプールシャフトB	SPOOL SHAFT (B)	
61-6-2	028050246	3	ハ"ネサ"ガ"ネ2-5	SPRING WASHER 2-5	
61-6-3	021500106	5	1シュナット5	NUT 5	
61-6-4	050503006	1	ナヘ"コヒラサ"5X30	WASHER SCREW 5X30	
61-6-5	050501406	1	ナヘ"コヒラサ"5X14	WASHER SCREW 5X14	
61-7	150180001	3	ウケサ"ラ	SPOOL STAND BASE	
61-8	150182000	3	スプールマット	SPOOL MAT	
61-9	126863001	3	スプールクッション	SPOOL CUSHION	
61-10	S02784009	1	ホルダー-ササエAセット	HOLDER SUPPORT (A) SET	
61-10-1	150188009	1	スプールホルダー-ササエA	SPOOL HOLDER SUPPORT (A)	
61-10-2	062501006	1	ナヘ"コ5X10	SCREW 5X10	
61-10-3	021500106	1	1シュナット5	NUT 5	
61-10-4	031452206	1	マルモク45X22	SCREW 45X22	
61-11	S02788009	1	スレット"ハンガ"ークミ3	THREAD HANGER ASSEMBLY 3	
61-12	S02747101	1	イトカケハ"ネ	SPRING	
61-13	150145009	1	イトアンナイホルダー-クミ	THREAD GUIDE HOLDER ASSEMBLY	
61-13-1	150185009	1	イトアンナイホルダー-	THREAD GUIDE HOLDER	
61-13-2	050503006	1	ナヘ"コヒラサ"5X30	WASHER SCREW 5X30	
61-13-3	021500106	1	1シュナット5	NUT 5	
61-14	142997001	1	イトアンナイ3	THREAD GUIDE 3	
61-15	S04109001	1	イトアンナイササエホ"ウ	THREAD GUIDE SUPPORT BAR	
61-16	138843001	1	ササエホ"ウツキ"テ	JOINT	
61-17	014060632	2	アナトメ6X6クホ"ミ	SET SCREW 6X6	

CODE	REF.NO.	PAGE
J00670001	Z2 - 21	38
S01005000	Z3 - 60-2-4	40
	Z3 - 61-2-3	40
S01297001	Z2 - 13-10	38
S02747101	Z3 - 60-12	40
	Z3 - 61-12	40
S02763202	Z3 - 60	40
S02777001	Z3 - 60-2	40
	Z3 - 61-2	40
S02778002	Z3 - 60-6	40
S02779009	Z3 - 61-5	40
S02780001	Z3 - 60-7	40
S02782001	Z3 - 61-6	40
S02784009	Z3 - 61-10	40
S02786002	Z3 - 60-11	40
S02788009	Z3 - 61-11	40
S04109001	Z3 - 61-15	40
S07558009	Z3 - 61	40
S18634001	Z2 - 13-5	38
S25564001	Z2 - 17	38
S25892001	L2 - 19	24
S25893001	M2- 59	32
S25894001	F - 27	14
	M1- 20	30
	M2- 54	32
S25895001	L2 - 18	24
S25898001	K - 20	22
S25899001	E - 12	12
S25900001	K - 1	22
S25901001	J2 - 30	20
S25902001	A - 11	2
S25903001	Z2 - 26	38
	Z2 - 38	38
S25904001	Z2 - 30	38
S25906001	A - 46	2
	K - 15	22
	N - 10	34
S25907001	G - 4-3	16
S25917001	A - 6	2
	H - 13	18
S25920001	A - 18	2
	A - 20	2
	K - 40	22
	K - 48	22
	L2 - 17	24
	M2- 85	32
	N - 14	34
	N - 16	34
S25922001	L3 - 19	26
	L3 - 45	26
S25927001	M1- 15	30
	M1- 26	30
S25929001	K - 16	22
S25931001	Z2 - 3	38
S25932001	Z2 - 4	38
S25933001	Z2 - 5	38
S25936001	Z2 - 19	38
S25940001	M2- 62	32
S25943001	Z2 - 6	38
S25947016	Z2 - 31	38
S25992001	B - 18	4
S25996001	J1 - 21	20
S25998001	B - 1	4
S25999001	B - 2	4
S26000001	B - 3	4
	G - 20	16
	H - 17	18

CODE	REF.NO.	PAGE
S26001001	B - 6	4
S26002001	B - 14	4
	B - 24	4
	B - 4	4
S26003001	B - 30	4
S26004001	G - 28	16
S26008001	B - 9	4
S26012001	C - 4	6
	D - 11	8
S26014001	C - 11	6
S26015001	C - 13	6
	C - 8	6
S26016001	D - 7	8
S26017001	C - 6	6
S26022001	J1 - 35	20
S26025001	D - 13	8
S26026001	D - 10	8
S26027001	A - 24	2
S26028001	A - 25	2
S26035001	D - 61	10
	D - 63	10
	G - 3	16
	P - 11	36
S26036001	B - 22	4
S26037001	B - 21	4
S26039001	B - 35	4
	B - 39	4
	F - 19	14
	H - 31	18
	K - 23	22
S26040001	B - 36	4
	H - 33	18
S26041001	B - 37	4
S26042001	B - 28	4
S26043001	B - 31	4
S26044001	G - 26	16
	H - 27	18
	H - 3	18
S26045001	B - 32	4
	B - 44	4
S26047001	B - 29	4
	H - 36	18
S26049001	B - 43	4
S26052001	H - 41	18
	H - 43	18
S26054001	G - 19	16
S26055001	G - 23	16
S26056001	G - 12	16
S26057001	A - 22	2
	G - 13	16
S26058001	G - 14	16
S26060001	H - 30	18
S26061001	H - 34	18
S26062001	H - 28	18
S26063001	H - 35	18
S26064001	H - 37	18
S26065001	H - 38	18
S26066001	H - 44	18
S26067001	H - 40	18
	L3 - 58	26
S26068001	H - 39	18
S26069001	H - 42	18
S26070001	H - 45	18
S26071001	H - 46	18
S26072001	H - 48	18
S26073001	H - 47	18
S26075001	F - 18	14

CODE	REF.NO.	PAGE
S26076001	F - 17	14
S26077001	F - 8	14
S26079001	F - 11	14
S26080001	F - 12	14
	L2 - 9	24
S26081001	F - 10	14
S26083001	G - 18	16
S26084001	H - 6	18
S26085001	H - 21	18
	H - 7	18
S26087001	L3 - 28	26
	P - 5	36
S26088001	L3 - 32	26
	L3 - 4	26
S26090001	H - 10	18
	H - 32	18
	H - 5	18
S26092001	D - 16	8
S26095001	F - 14	14
S26096001	F - 15	14
	H - 25	18
S26097001	F - 16	14
	H - 24	18
S26102001	L3 - 25	26
	L3 - 55	26
S26107001	L1 - 6	24
S26108001	L3 - 20	26
S26109001	L3 - 27	26
	L3 - 57	26
S26110001	L3 - 13	26
	L3 - 39	26
S26111001	L3 - 14	26
	L3 - 40	26
S26112001	L3 - 15	26
	L3 - 41	26
S26114001	L3 - 21	26
	L3 - 47	26
S26115001	L3 - 22	26
S26116001	L3 - 23	26
	L3 - 49	26
S26122001	G - 5	16
S26124001	D - 4	8
S26125001	D - 5	8
S26129001	D - 1	8
S26130001	D - 57	8
S26131001	D - 2	8
	D - 58	8
	F - 22	14
	K - 29	22
S26132001	D - 60	10
S26133001	D - 62-1	10
S26134001	D - 62	10
S26135001	D - 62-3	10
S26136001	D - 62-2	10
S26137001	L3 - 26	26
	L3 - 56	26
S26141001	B - 23	4
S26142001	B - 7	4
	C - 5	6
S26143001	B - 10	4
S26144001	B - 26	4
	H - 16	18
S26148001	Z2 - 7	38
S26149001	Z2 - 11	38
S26150001	F - 30	14
	F - 39	14
	K - 25	22

CODE	REF.NO.	PAGE
S26150001	K - 28	22
S26151001	L1 - 4	24
S26152001	L1 - 5	24
S26153001	C - 2	6
	D - 20	8
	D - 29	8
	D - 8	8
	G - 22	16
S26154001	G - 25	16
S26155001	B - 5	4
	G - 24	16
S26156001	F - 35	14
	H - 22	18
	H - 8	18
	J1 - 22	20
S26157001	F - 9	14
S26158001	H - 11	18
S26162001	F - 6	14
S26166001	H - 1	18
S26169001	L3 - 18	26
S26170001	L3 - 12	26
S26185001	C - 3	6
S26186001	D - 14	8
S26187001	D - 12	8
S26188001	C - 7-1	6
S26189001	C - 10	6
S26197001	L3 - 44	26
S26198001	L3 - 37	26
S26199001	L3 - 46	26
S26200001	L3 - 48	26
S26204001	L3 - 38	26
S26207001	A - 23	2
S26208001	L1 - 1	24
	L2 - 1	24
S26209001	A - 4	2
S26210001	B - 17	4
S26212001	B - 15	4
S26213001	G - 21	16
	G - 27	16
S26214001	G - 30	16
S26215001	H - 2	18
S26220001	A - 21	2
	D - 68	8
	P - 12	36
	P - 6	36
S26221001	B - 25	4
S26222001	D - 6	8
S26224001	P - 4	36
S26225001	Z2 - 27	38
S26227001	Z2 - 28	38
S26228001	Z2 - 25	38
S26233001	Z2 - 36	38
S26250001	D - 66	8
S26261001	Z2 - 29	38
S26265001	K - 22	22
S26268001	F - 34	14
S26269001	F - 2	14
S26271001	F - 3	14
S26272001	F - 32	14
	F - 40	14
	M2 - 64	32
S26273001	F - 5	14
S26276001	F - 33	14
S26279001	F - 42	14
S26280001	Z2 - 8	38
S26285001	C - 1	6
S26321001	J1 - 16	20

CODE	REF.NO.	PAGE
S26321001	J1 - 37	20
	J2 - 18	20
S26329001	J1 - 31	20
	J2 - 28	20
S26331001	J1 - 33	20
S26332001	J1 - 34	20
S26333001	G - 1	16
	J2 - 23	20
S26334001	G - 4-1	16
S26335001	G - 4	16
S26336001	G - 4-2	16
S26337001	G - 7	16
S26338001	G - 8	16
S26340001	B - 27	4
S26342001	C - 12	6
	J1 - 15	20
	J1 - 30	20
	J1 - 36	20
	J2 - 17	20
	J2 - 27	20
S26343001	C - 12	6
S26344001	C - 12	6
S26346001	J2 - 29	20
S26354001	P - 7	36
S26357001	K - 32	22
S26358001	M2- 42	32
	P - 2	36
S26381001	G - 11	16
S26405001	E - 5	12
S26449001	D - 15	8
S26453001	D - 3	8
S26457001	B - 33	4
S26458001	B - 34	4
S26459001	G - 6	16
	M2- 74	32
S26460001	L1 - 2	24
	L2 - 2	24
S26533001	G - 36	16
	J1 - 18	20
	J1 - 25	20
	J1 - 29	20
	J2 - 26	20
	J2 - 9	20
S26534001	J1 - 27	20
	J2 - 21	20
	M1- 39	30
	M1- 8	30
	P - 8	36
S26536001	Z2 - 12	38
S26537001	A - 2	2
S26538001	A - 3	2
	L3 - 11	26
S26539001	B - 13	4
S26540001	F - 7	14
S26542001	F - 1	14
S26545001	B - 19	4
S26546001	B - 16	4
S26551001	B - 8	4
S26554001	L3 - 3	26
S26555001	A - 5	2
S26556001	A - 8	2
S26557001	A - 7	2
S26559001	A - 9	2
S26561001	A - 34	2
S26565001	A - 19	2
S26573001	B - 20	4
S26575001	F - 29	14

CODE	REF.NO.	PAGE
S26575001	Z2 - 10	38
S26576001	Z2 - 9	38
S26585001	D - 19	8
S26587001	K - 31	22
	P - 9	36
S26922001	L3 - 1	26
S26934001	M1- 13	30
	M1- 28	30
S26935001	G - 17	16
	M1- 17	30
	M1- 19	30
	M1- 24	30
S26948001	E - 18	12
	Z1 - 48	36
S26949001	E - 17	12
	Z1 - 47	36
S26960001	L3 - 6	26
S26961001	L3 - 34	26
	L3 - 7	26
S26962001	L3 - 36	26
	L3 - 9	26
S26963001	L3 - 35	26
	L3 - 8	26
S26967001	H - 19	18
S26971001	A - 15	2
S26972001	M2- 46	32
S26983001	L3 - 16	26
	L3 - 42	26
S26987001	L2 - 11	24
S26988001	L2 - 10	24
S26989001	L2 - 8	24
S26990001	L2 - 7	24
S26991001	L3 - 24	26
S26992001	L3 - 31	26
S26993001	Z2 - 35	38
S26994001	L3 - 10	26
S26996001	L2 - 12	24
	M2- 81	32
S26997001	L2 - 13	24
	M2- 82	32
S26998001	L2 - 15	24
	M2- 83	32
	N - 12	34
S26999001	K - 39	22
	K - 47	22
	L2 - 16	24
	M2- 84	32
	N - 13	34
S27001001	K - 8	22
	M2- 53	32
S27002001	M2- 75	32
S27003001	M1- 31	30
	M1- 9	30
S27004001	M2- 76	32
S27006001	M2- 78	32
S27007001	A - 13	2
	M2- 77	32
	N - 17	34
	N - 19	34
S27008001	M2- 79	32
S27011001	N - 20-8	34
S27012001	K - 42	22
S27014001	N - 20-15	34
S27016001	P - 1	36
S27022001	E - 20	12
	K - 43	22
	N - 20-5	34

CODE	REF.NO.	PAGE
S27022001	Z1 - 51	36
S27024001	Z2 - 20	38
S27028001	K - 9	22
S27029001	K - 38	22
	K - 46	22
	N - 11	34
S27030001	N - 20-11	34
S27033001	E - 9	12
S27035001	E - 11	12
S27037001	E - 16	12
	Z1 - 46	36
S27040001	E - 24	12
	Z1 - 40	36
S27044001	E - 25	12
	Z1 - 41	36
S27048001	E - 26	12
	Z1 - 43	36
S27050001	E - 19	12
	Z1 - 50	36
S27052001	E - 29	12
	K - 41	22
	N - 20-17	34
	Z1 - 54	36
S27054001	L2 - 10	24
S27055001	L3 - 54	26
S27056001	L2 - 8	24
S27057001	L3 - 33	26
S27058001	L2 - 11	24
S27065001	L3 - 53	26
S27066001	L3 - 50	26
S27067001	D - 33	8
	L3 - 52	26
S27068001	D - 32	8
	L3 - 51	26
S27069001	E - 6	12
S27071001	L3 - 2	26
S27085001	K - 30	22
S27086001	K - 34	22
S27093001	A - 27	2
S27140001	D - 27	8
S27146001	D - 23	8
S27147001	D - 21	8
S27148001	D - 25	8
S27149001	D - 26	8
S27208001	D - 44	8
S27211001	D - 24	8
	D - 49	8
S27214001	D - 45	8
S27215001	D - 46	8
S27216001	D - 43	8
S27217001	D - 41	8
S27219001	D - 51	8
S27220001	D - 54	8
S27221001	D - 53	8
S27222001	D - 55	8
S27223001	D - 56	8
S27224001	D - 50	8
S27225001	D - 67	10
S27251001	D - 18	8
S27275001	J1 - 20	20
	J2 - 19	20
S27293001	D - 36	8
S27313001	J1 - 13	20
	J2 - 15	20
S27314001	J1 - 14	20
	J2 - 16	20
S27341001	L3 - 17	26

CODE	REF.NO.	PAGE
S27341001	L3 - 43	26
S27389001	D - 67	10
S27390001	D - 67	10
S27397001	D - 67	10
S27398001	D - 67	10
S27454001	D - 65	10
S27524001	M2- 55	32
	M2- 66	32
S27528001	M1- 12	30
	M1- 27	30
S27545001	J1 - 17-2	20
	J2 - 8-2	20
S27546001	J1 - 17-3	20
	J2 - 8-3	20
S27557001	E - 14	12
S27562001	M1- 23	30
S27564001	M1- 22	30
S27593001	L3 - 5	26
S27596001	M2- 61	32
S27597001	M2- 65	32
S27598001	M2- 73	32
S27612001	E - 23	12
S27709001	N - 20-10	34
S27719001	K - 33	22
S27720001	K - 36	22
S27721001	K - 35	22
S27727001	G - 9	16
	M2- 63	32
	P - 10	36
S27732001	B - 41	4
S27733001	B - 42	4
S27734001	M2- 72	32
	P - 14	36
S27735001	K - 44	22
S27737001	G - 15	16
S27740001	E - 15	12
	Z1 - 42	36
S27741001	E - 13	12
	Z1 - 49	36
S27743001	M1- 18	30
	M2- 52	32
S27744001	M2- 57	32
S27745001	M2- 58	32
S27751001	J1 - 3-2	20
	J2 - 3-2	20
S27754001	J1 - 3-4	20
	J2 - 3-4	20
	J2 - 3-5	20
S29043001	A - 53	2
S29249001	E - 21	12
	Z1 - 53	36
S29250001	E - 22	12
	Z1 - 52	36
S29264001	M1- 33	30
	M1- 4	30
S29265001	M1- 3	30
	M1- 35	30
S29266001	J1 - 2	20
	J2 - 2	20
	Z2 - 32	38
S29267001	D - 42	8
S29268001	D - 52	8
S29269001	D - 52	10
S29270001	J1 - 19	20
S29271001	G - 2-1	16
S29272001	J1 - 3	20
	J2 - 3	20

CODE	REF.NO.	PAGE
S29273001	J1 - 17-1	20
	J2 - 8-1	20
S29274001	M1- 10	30
	M1- 30	30
	Z2 - 33	38
S29275001	M1- 37	30
	M1- 5	30
	Z2 - 34	38
S29276001	M1- 38	30
	M1- 7	30
S29277001	M1- 2	30
	M1- 34	30
S29278001	D - 64	10
S29279001	D - 64	10
S29280001	D - 64	10
S29281001	J2 - 31	20
S29282001	J2 - 31	20
S29283001	J2 - 31	20
S29284001	G - 2-2	16
S29285001	G - 2-2	16
S29286001	G - 2-2	16
S29291001	G - 33	16
S29301001	P - 3	36
S29302001	P - 13	36
S29306001	Z2 - 16	38
S29307001	Z2 - 18	38
S29308001	Z2 - 37	38
S29310001	A - 1	2
S29312001	A - 14	2
S29313001	A - 16	2
S29314001	A - 17	2
S29315001	A - 26	2
S29316001	A - 29	2
S29317001	A - 30	2
S29318001	A - 31	2
S29319001	A - 32	2
S29320001	A - 33	2
S29321001	A - 35	2
S29322001	A - 36	2
S29323001	A - 37	2
S29324001	A - 38	2
S29325001	A - 39	2
S29326001	A - 40	2
S29327001	A - 41	2
S29328001	A - 42	2
S29329001	A - 43	2
S29330001	A - 44	2
S29331001	A - 45	2
S29332001	A - 47	2
S29333001	A - 48	2
S29334001	A - 49	2
S29335001	A - 10	2
S29336001	B - 11	4
S29337001	B - 12	4
S29338001	B - 38	4
S29339001	B - 40	4
S29340001	C - 7-2	6
S29341001	C - 14	6
S29345001	D - 9	8
S29346001	D - 17	8
S29347001	D - 22	8
S29348001	D - 28	8
S29349001	D - 30	8
S29350001	D - 31	8
S29351001	D - 34	8
S29352001	D - 35	8
S29353001	D - 37	8

CODE	REF.NO.	PAGE
S29354001	D - 38	8
S29355001	D - 40	8
S29356001	D - 39	8
S29357001	D - 47	8
S29358001	D - 48	8
S29359001	D - 59	8
S29360001	E - 1	12
S29361001	E - 4	12
S29482001	E - 7	12
S29483001	E - 8	12
S29484001	E - 10	12
S29485001	F - 4	14
	F - 41	14
S29486001	F - 13	14
S29487001	F - 20	14
S29488001	F - 21	14
S29489001	F - 23	14
S29491001	F - 26	14
S29492001	F - 24	14
S29493001	F - 31	14
S29494001	F - 36	14
S29495001	F - 37	14
S29496001	F - 38	14
S29497001	G - 10	16
S29498001	G - 16	16
S29499001	G - 29	16
S29500001	G - 32	16
S29501001	G - 31	16
S29502001	G - 34	16
S29503001	G - 35	16
S29504001	L3 - 30	26
S29505001	H - 4	18
S29507001	H - 12	18
S29508001	H - 14	18
S29509001	H - 15	18
	H - 9	18
S29510001	H - 18	18
S29511001	H - 20	18
S29512001	H - 23	18
S29513001	H - 26	18
S29514001	H - 29	18
S29515001	H - 9	18
S29516001	J1 - 4	20
	J2 - 4	20
S29517001	J1 - 9	20
	J2 - 11	20
S29518001	J1 - 10	20
	J2 - 12	20
S29519001	J1 - 11	20
	J2 - 13	20
S29520001	J1 - 5	20
	J2 - 10	20
S29521001	J1 - 12	20
	J2 - 14	20
S29522001	J1 - 6	20
	J2 - 5	20
S29523001	J1 - 7	20
	J2 - 6	20
S29524001	J1 - 23	20
S29525001	J1 - 32	20
S29526001	J1 - 26	20
S29527001	J1 - 24	20
S29528001	J1 - 28	20
S29529001	J1 - 17	20
	J2 - 8	20
S29530001	J2 - 20	20
S29531001	J2 - 22	20

CODE	REF.NO.	PAGE
S29532001	J2 - 24	20
S29533001	J2 - 25	20
S29534001	K - 3	22
S29535001	K - 2	22
S29536001	K - 4	22
S29537001	K - 5	22
S29538001	K - 7	22
S29540001	K - 10	22
S29541001	K - 14	22
S29542001	K - 12	22
S29543001	K - 11	22
S29544001	K - 13	22
	N - 5	34
S29545001	K - 17	22
S29546001	K - 18	22
S29547001	K - 21	22
S29548001	K - 19	22
S29549001	K - 24	22
S29550001	K - 26	22
S29551001	K - 27	22
S29552001	K - 37	22
	N - 1	34
S29553001	K - 45	22
S29554001	J1 - 8	20
	J2 - 7	20
	L1 - 3	24
S29555001	L2 - 14	24
	N - 2	34
S29556001	M1- 1	30
S29557001	M1- 36	30
	M1- 6	30
S29558001	M1- 11	30
	M1- 29	30
S29559001	M1- 14	30
	M1- 25	30
S29560001	M1- 16	30
S29561001	M1- 21	30
S29562001	M1- 32	30
S29563001	M2- 50	32
S29564001	M2- 69	32
S29565001	M2- 43	32
S29566001	M2- 49	32
S29567001	M2- 45	32
	M2- 48	32
S29568001	M2- 41	32
S29569001	M2- 44	32
S29570001	M2- 47	32
	M2- 51	32
S29571001	M2- 56	32
S29572001	M2- 60	32
S29573001	M2- 67	32
S29574001	M2- 68	32
S29575001	M2- 70	32
S29576001	M2- 71	32
S29577001	M2- 80	32
	N - 6	34
S29578001	N - 3	34
S29579001	N - 4	34
S29580001	N - 7	34
S29581001	N - 8	34
S29582001	N - 9	34
S29583001	N - 15	34
S29584001	N - 18	34
S29585001	N - 20	34
S29586001	N - 20-1	34
S29587001	N - 20-2	34
S29588001	N - 20-3	34

CODE	REF.NO.	PAGE
S29589001	N - 20-4	34
S29590001	N - 20-6	34
S29591001	N - 20-7	34
S29592001	N - 20-9	34
S29593001	N - 20-12	34
S29594001	N - 20-13	34
S29595001	N - 20-14	34
S29596001	N - 20-16	34
S29608001	Z1 - 55	36
S29620001	P - 15	36
S29703001	A - 12	2
S29753001	J1 - 3-1	20
	J2 - 3-1	20
S29761001	J1 - 3-3	20
	J2 - 3-3	20
S29762001	J1 - 3-5	20
S29767001	J1 - 3-6	20
	J2 - 3-6	20
S29768001	L3 - 59	26
014060632	Z3 - 61-17	40
021060302	A - 51	2
	E - 2	12
021500106	Z3 - 60-4-2	40
	Z3 - 60-7-3	40
	Z3 - 61-10-3	40
	Z3 - 61-13-3	40
	Z3 - 61-3-2	40
	Z3 - 61-6-3	40
025060132	A - 52	2
	E - 3	12
028050246	Z3 - 60-7-2	40
	Z3 - 61-6-2	40
031452206	Z3 - 61-10-4	40
050501406	Z3 - 60-7-5	40
	Z3 - 61-6-5	40
050503006	Z3 - 60-7-4	40
	Z3 - 61-13-2	40
	Z3 - 61-6-4	40
062501006	Z3 - 61-10-2	40
062501406	Z3 - 60-4-1	40
	Z3 - 61-3-1	40
100366002	Z2 - 13-6	38
100401001	Z2 - 13-2	38
100657001	Z2 - 13-7	38
100659001	Z2 - 13-8	38
100662001	Z2 - 13-9	38
100666002	Z2 - 14	38
101118001	E - 28	12
	Z1 - 45	36
104449009	A - 28	2
117963110	Z2 - 13	38
117969001	Z2 - 13-3	38
117970001	Z2 - 13-4	38
122991001	Z2 - 1	38
126863001	Z3 - 60-10	40
	Z3 - 61-9	40
138843001	Z3 - 61-16	40
142997001	Z3 - 61-14	40
144222001	Z2 - 2	38
145446001	Z2 - 13-1	38
145646016	C - 9	6
147733001	E - 27	12
	Z1 - 44	36
150106003	Z3 - 60-4	40
	Z3 - 61-3	40
150145009	Z3 - 61-13	40
150172003	Z3 - 60-3	40

CODE	REF.NO.	PAGE
150172003	Z3 - 61-4	40
150174000	Z3 - 60-2-3	40
	Z3 - 60-5	40
	Z3 - 61-2-4	40
	Z3 - 60-7-1	40
150179002	Z3 - 61-6-1	40
	Z3 - 60-8	40
150180001	Z3 - 61-7	40
	Z3 - 60-9	40
150182000	Z3 - 61-8	40
	Z3 - 61-13-1	40
150185009	Z3 - 61-10-1	40
150188009	Z3 - 60-2-2	40
	Z3 - 61-2-2	40
150191002	Z3 - 60-2-1	40
	Z3 - 61-2-1	40
150206002	Z3 - 61-2-1	40
154702001	Z2 - 15	38
156112003	Z3 - 60-1	40
	Z3 - 61-1	40

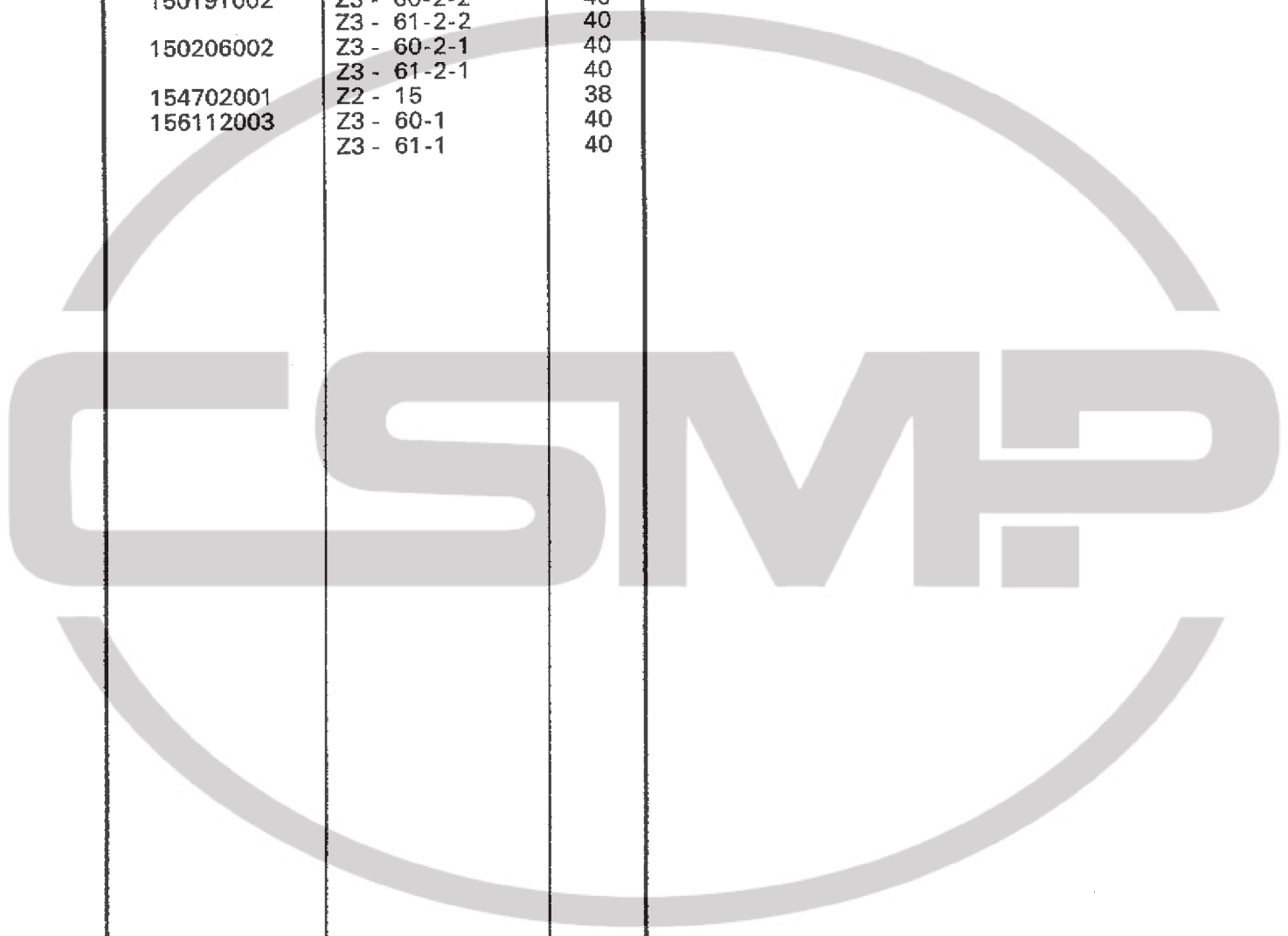





ブラザー工業株式会社

〒467 名古屋市瑞穂区河岸一丁目1番1号
TEL (052) 824-2392(代)

BROTHER INDUSTRIES, LTD. NAGOYA, JAPAN

118-S62
195S62-001
1992, 03

Printed in Japan/Gedruckt in Japan/Imprimé au Japon/Impreso en Japón