

FD3-B256 FD3-B257

パーツブック
PARTS BOOK
TEILEKATAROG
LIVRE DES PIECES
LIBRO DE REFERENCIA DE PIEZAS

筒型片面飾り縫自動糸切りミシン
筒型両面飾り縫自動糸切りミシン

CYLINDER BED BOTTOM COVERING STITCHER WITH THREAD TRIMMER
CYLINDER BED TOP AND BOTTOM COVERING STITCHER WITH THREAD TRIMMER

HOCHLEISTUNGS-ZYLINDERBETT-UNTERDECKSTICHMASCHINE MIT FADENABSCHNEIDER

HOCHLEISTUNGS-ZYLINDERBETT-UNTERDECKSTICHMASCHINE MIT FADENABSCHNEIDER UND OBEREM UND UNTEREM LEGEFADEN

MACHINE CANON A RECOUVREMENT INFERIEUR AVEC COUPE-FIL
MACHINE CANON A RECOUVREMENT SUPERIEUR ET INFERIEUR AVEC COUPE-FIL

RECUBRIDORA CILINDRICA A UNA CARA, CON CORTAHILOS
RECUBRIDORA CILINDRICA A DOS CARAS, CON CORTAHILOS

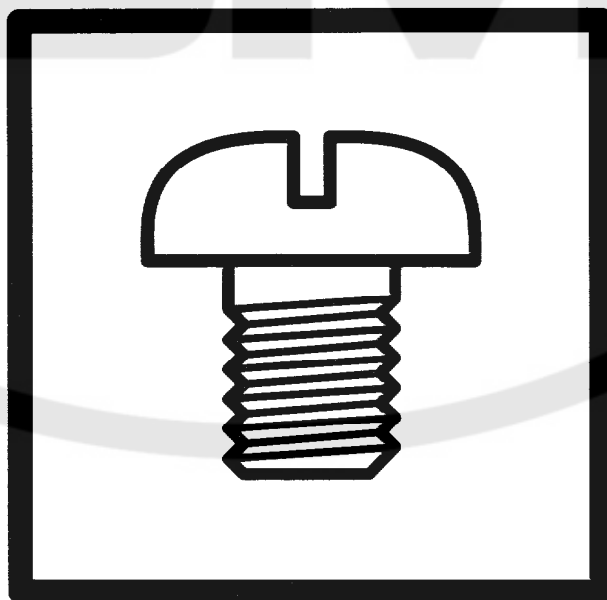

P256101

brother.

Notes sur l'utilisation de ce manuel de pièces détachées

1. Ce manuel est destiné aux machines à coudre ayant le même numéro de plaque montré sur la couverture de ce manuel (ou sur la feuille de corrections).
2. Les pièces non-standard sont indiquées para un

033 051

. Les numéros de la ligne indiquent la sous-classification.
3. Ce manuel a été fait d'après les renseignements valables au mois de Mars 1994.
4. Les pièces peuvent être sujettes à des modifications sans préavis.
5. Les pièces fournies en tant qu'assemblages complets sont encadrées avec un trait pointillé [] .
6. Vérifier la liste des pièces de calibrage (page 101) s'il y a un astérisque * dans le code des pièces ou la colonne des remarques.

TABLE DES MATIERES

A1~A4. Corps de la machine	1
B. Mécanisme de arbre supérieur et barra à aiguille	13
C1~C2. Mécanisme de pied presseur	17
D. Mécanisme du refroidisseur d'aiguille	21
E1~E2. Mécanisme de l'entraînement	23
F. Mécanisme de l'arbre inférieur	29
G. Mécanisme des griffes	31
H. Lubrification	33
J. Mécanisme de l'etendeur (B257)	35
K1. Tension du fil (B256)	37
K2. Tension du fil (B257)	41
L. Mécanisme à rabat (B257-OV1)	45
M. Mécanisme due puller (056,061,0V1,0W1,0X6)	47
N1. Mécanisme de couteau rafraîchisseur (0W1)	51
N2. Mécanisme de couteau rafraîchisseur (0X1,0X6)	53
P. Dispositif de couture (0W1)	55
Q. Synchronisateur	57
R. Mécanisme de tire-fil (B256-UT12,14,22,24)	57
S1~S2. Mécanisme de coupe-fils inférieur	59
T. Mécanisme de coupe-fils supérieur (B257-UT32,34) ..	67
U. Conjunto aéreo del levantador del pie	69
V. Dispositif pneumatique de releveur de pied presseur ..	71
W1. Dispositif de rouleaux de tension du tissu (056,0V1,0X6)	73
W2. Dispositif de rouleaux de tension du tissu (0W1)	75
X1~X3. Jeu d'accessoires	77
Z1~Z4. Accessoires	83
INDEX	91~100
LISTE DES PIECES D'ECARTEMENT	101~108

A1. 主体関係 / Machine body / Maschinengehäuse /
 Corps de la machine / Cuerpo de la máquina

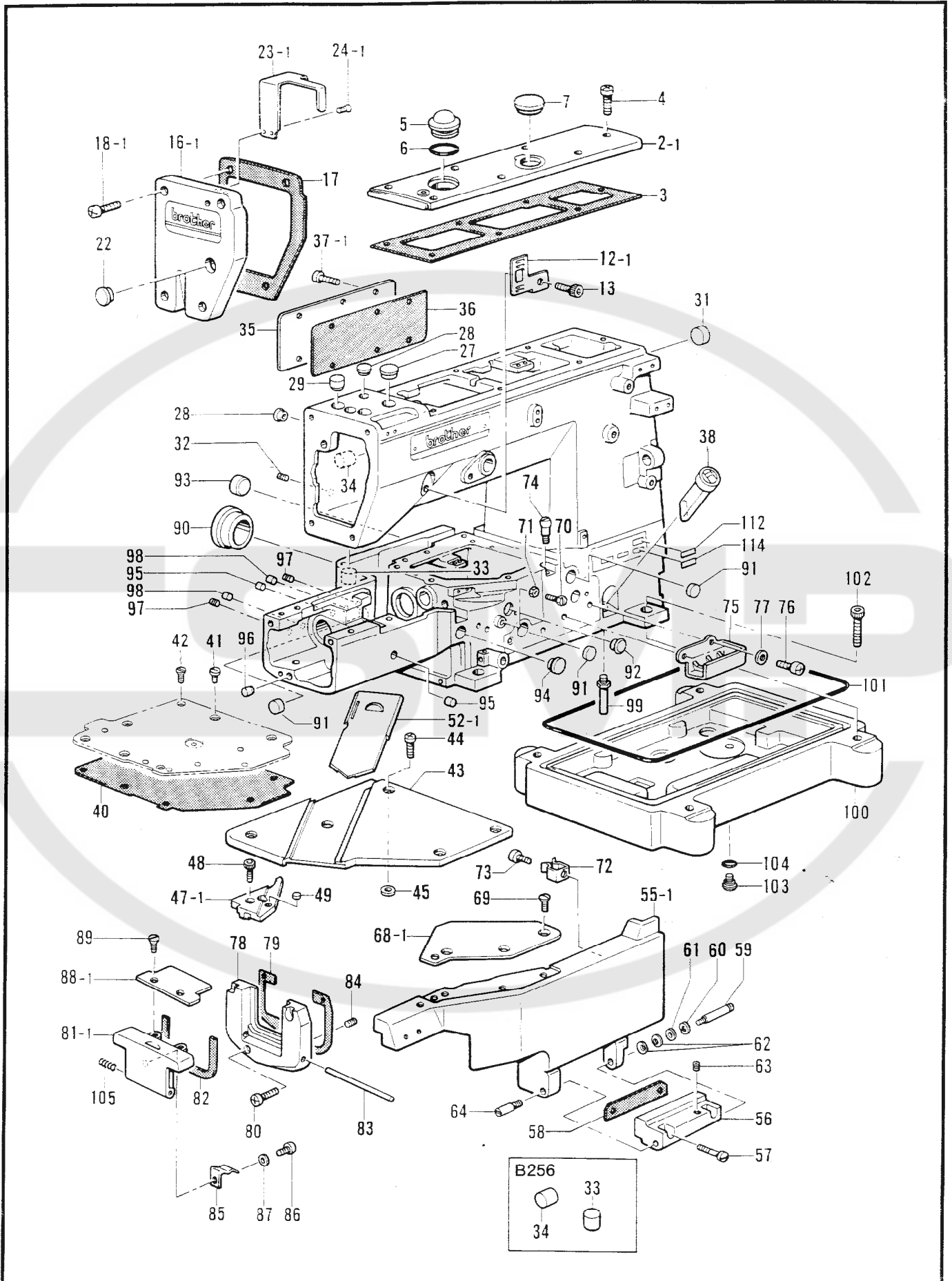

A1. 主体関係 / Machine body / Maschinengehäuse /
Corps de la machine / Cuerpo de la máquina

REF.NO.	CODE	Q'TY	ヒンメイ	NAME OF PARTS	RM
2-1	S08627001	1	ウワフタ	TOP COVER	
3	S08628000	1	ウワフタパツキン	TOP COVER PACKING	
4	062681012	7	ナベコ437-40X10	SCREW, PAN M4.37-40X10	
5	S02606000	1	ユリヨウケイマド	OIL GAUGE WINDOW	
6	081014670	1	OリングPW14	O RING, PW14	
7	159150009	1	カマジクメクラセン	OIL CAP	
12-1	S08629009	1	ハリイトクリカバー	NEEDLE THREAD TAKE-UP COVER	
13	018060822	1	アナボルト6X8	BOLT, SOCKET M6X8	
16-1	S08630201	1	メンイタ	FACE PLATE	
17	S08631000	1	メンイタパツキン	FACE PLATE PACKING	
18-1	062681612	4	ナベコ437-40X16	SCREW, PAN M4.37-40X16	
22	117934009	1	メクラセン	OIL CAP	
23-1	S08632009	1	ハリボウテンピンカバー	NEEDLE BAR TAKE-UP COVER	
24-1	102843004	2	サラネジ3.57	SCREW, FLAT M3.57	
27	104449009	1	メクラセン	OIL CAP	
28	104450109	2	メクラセン	OIL CAP	
29	154841009	1	メクラセン	OIL CAP	
31	S00313009	1	メクラセン	OIL CAP	
32	014060622	1	アナトメネジ6X6クボミ	SET SCREW, SOCKET (CP) M6X6	
35	S28007001	1	ガワイタ	REAR COVER	
36	S28008000	1	ガワイタパツキン	REAR COVER PACKING	
37-1	062680812	6	ナベコ437-40X8	SCREW, PAN M4.37-40X8	
38	148084001	1	オイルゲージマド	OIL GAUGE WINDOW	
40	S28011000	1	ベツトウワカバーパツキン	BED UPPER COVER PACKING	
41	107407003	5	シメネジ4.37	SCREW, M4.37	
42	107272002	2	サラネジ4.37	SCREW, FLAT M4.37	
43	S28012001	1	クロスプレートA	CLOTH PLATE (A)	
44	060681212	4	バインド437-40X12	SCREW, BIND M4.37-40X12	
45	S28014000	4	クロスプレートパツキン	CLOTH PLATE PACKING	
47-1	S28765001	1	クロスプレートSA	CLOTH PLATE (SA)	
48	018681232	2	アナボルト437-40X12	BOLT, SOCKET M4.37-40X12	
49	S28820000	1	ホジヨイタアテゴム	SUPPORT PLATE RUBBER	
52-1	S28492001	1	スベリイタE	SLIDE PLATE (E)	
55-1	S28027001	1	マエカバーA	FRONT COVER (A)	
56	S28031001	1	マエカバーササエ	FRONT COVER SUPPORT	
57	102424004	2	シメネジ4.37	SCREW, M4.37	
58	S28157000	1	マエカバーササエパツキン	FRONT COVER SUPPORT PACKING	
59	S28032001	1	マエカバーササエジクR	FRONT COVER SUPPORT SHAFT (R)	
60	048040342	1	トメワE4	RETAINING RING, E4	
61	025050132	1	ヒラザガネシヨウ5	WASHER, PLAIN S 5	
62	146598001	2	バネザガネ	WASHER, SPRING	
63	014680622	1	アナトメネジ4.37クボミ	SET SCREW, SOCKET (CP) M4.37	
64	S28033000	1	マエカバーササエジクL	FRONT COVER SUPPORT SHAFT (L)	
68-1	S28814001	1	ホジヨイタB	SUPPORT PLATE (B)	
69	107231002	3	サラネジ4.76	SCREW, FLAT M4.76	
70	154574001	1	ボルト4.37	BOLT, M4.37	
71	105234003	1	ナツト4.37	NUT, M4.37	
72	S28034101	1	カバートメバネ	COVER SET SPRING	
73	062710612	1	ナベコ476-32X6	SCREW, PAN M4.76-32X6	
74	S28035001	1	バネウケネジ	SCREW	
75	S28812000	1	シタイトテンピンカバー	LOOPER THREAD TAKE-UP COVER	
76	062680812	2	ナベコ437-40X8	SCREW, PAN M4.37-40X8	
77	100645003	2	ザガネ	WASHER	
78	S28036001	1	ヨコカバーササエA	SIDE COVER SUPPORT (A)	
79	S28037000	1	ヨコカバーササエパツキン	SIDE COVER SUPPORT PACKING	
80	062681612	3	ナベコ437-40X16	SCREW, PAN M4.37-40X16	
81-1	S28038001	1	ヨコカバーA	SIDE COVER (A)	
82	S28039000	1	ヨコカバーパツキン	SIDE COVER PACKING	
83	S28040000	1	ヨコカバーササエジク	SIDE COVER SUPPORT SHAFT	

A1. 主体関係 / Machine body / Maschinengehäuse /
 Corps de la machine / Cuerpo de la máquina

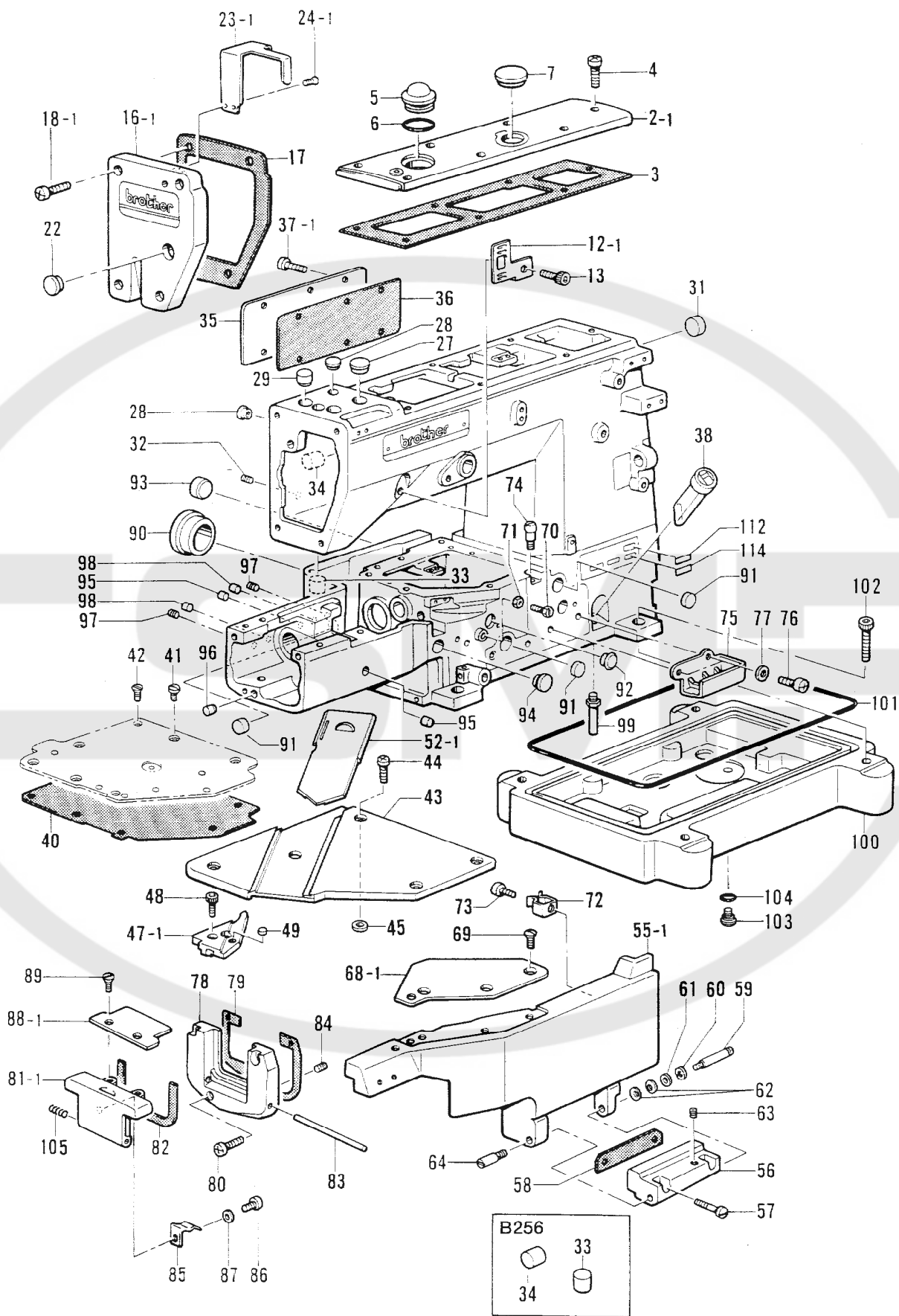

A1. 主体関係 / Machine body / Maschinengehäuse /
Corps de la machine / Cuerpo de la máquina

REF.NO.	CODE	Q'TY	ヒンメイ	NAME OF PARTS	RM
84	148294001	2	アナトメネジ3.57クボミ	SET SCREW, SOCKET (CP) M3.57	
85	S28156001	1	ヨコカバートメバネ	SIDE COVER SET SPRING	
86	062680712	1	ナベコ437-40X7	SCREW, PAN M4.37-40X7	
87	100645003	1	ザガネ	WASHER	
88-1	S28041001	1	ヨコカバークワイタA	SIDE COVER UPPER PLATE (A)	
89	S01696002	2	サラネジ3.57X6	SCREW, FLAT M3.57X6	
90	S28043009	1	メクラセン	OIL CAP	
91	S28044009	3	メクラセン	OIL CAP	
92	104449009	1	メクラセン	OIL CAP	
93	140066009	1	メクラセン	OIL CAP	
94	104450109	1	メクラセン	OIL CAP	
95	142274009	2	メクラセン	OIL CAP	
96	156217009	1	メクラセン	OIL CAP	
97	014060622	2	アナトメネジ6X6クボミ	SET SCREW, SOCKET (CP) M6X6	
98	142274009	2	メクラセン	OIL CAP	
99	104830101	4	キヤクチュウS	BED LEG (S)	
100	S28045000	1	アブラウケ	OIL RESERVOIR	
101	S28046000	1	Oリング	O RING	
102	018081622	4	アナボルト8X16	BOLT, SOCKET M8X16	
103	110641002	1	ダンネジ9.52	STUD SCREW, M9.52	
104	109203001	1	Oリング	O RING	
105	S28850001	1	ヨコカバークササエジクバネ	SPRING	
112	※	1	シヨウラベル	LABEL	
114	S10696027	1	ソウチヒヨウジラベル (UT11)	DEVICE LABEL (UT11)	
114	S10696029	1	ソウチヒヨウジラベル (UT13)	DEVICE LABEL (UT13)	
114	S10696033	1	ソウチヒヨウジラベル (UT21)	DEVICE LABEL (UT21)	
114	S10696035	1	ソウチヒヨウジラベル (UT23)	DEVICE LABEL (UT23)	
			<B256>		
33	154841009	1	メクラセン	OIL CAP	
34	156887001	1	メクラセン17	OIL CAP 17	
114	S10696028	1	ソウチヒヨウジラベル (UT12)	DEVICE LABEL (UT12)	
114	S10696030	1	ソウチヒヨウジラベル (UT14)	DEVICE LABEL (UT14)	
114	S10696034	1	ソウチヒヨウジラベル (UT22)	DEVICE LABEL (UT22)	
114	S10696036	1	ソウチヒヨウジラベル (UT24)	DEVICE LABEL (UT24)	
			<B257>		
114	S10696031	1	ソウチヒヨウジラベル (UT32)	DEVICE LABEL (UT32)	
114	S10696032	1	ソウチヒヨウジラベル (UT34)	DEVICE LABEL (UT34)	
114	S10696037	1	ソウチヒヨウジラベル (UT42)	DEVICE LABEL (UT42)	
114	S10696038	1	ソウチヒヨウジラベル (UT44)	DEVICE LABEL (UT44)	
			<オプションパーツ>	<OPTION PARTS>	
114	S10696039	1	ソウチヒヨウジラベル (CS1)	DEVICE LABEL (CS1)	

A2. 主体関係 / Machine body / Maschinengehäuse /
 Corps de la machine / Cuerpo de la máquina

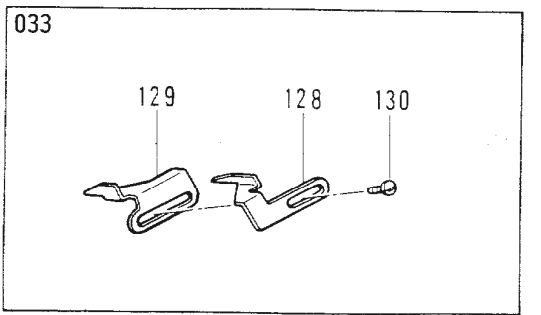
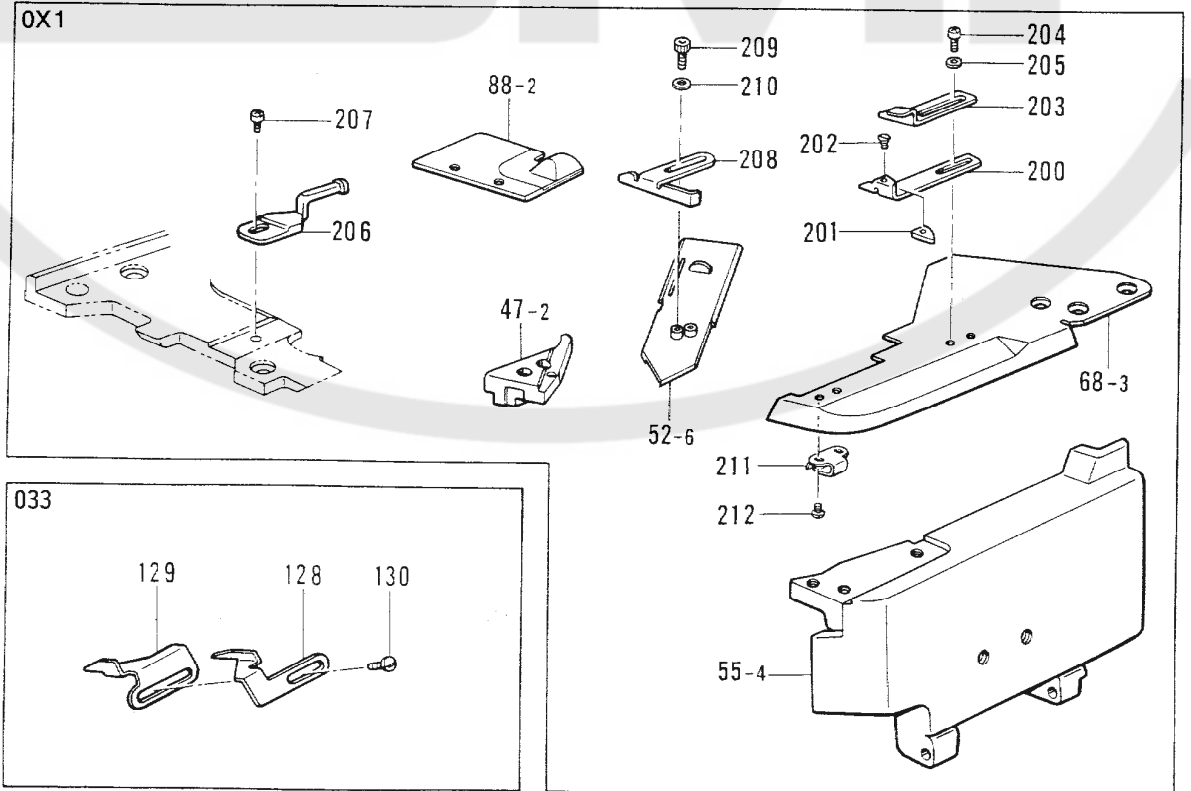
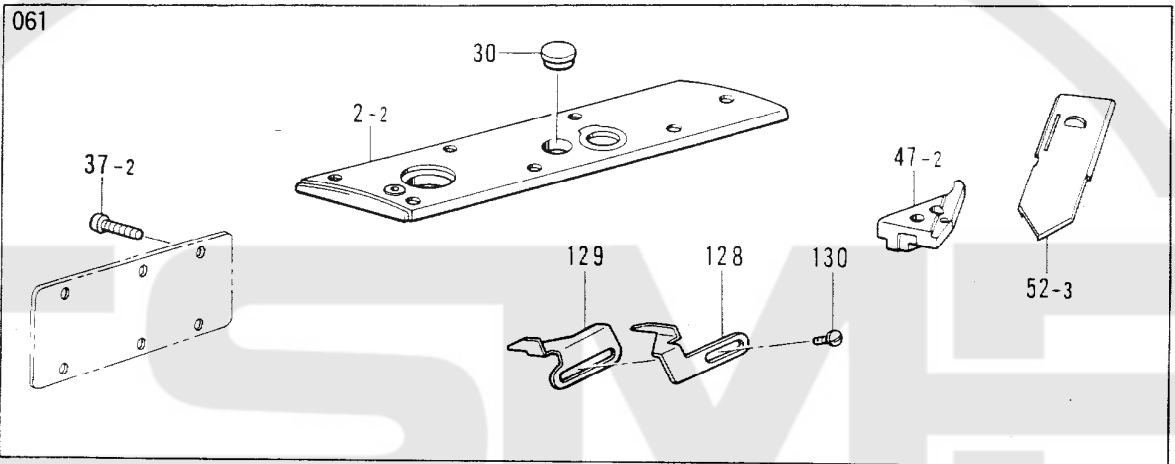
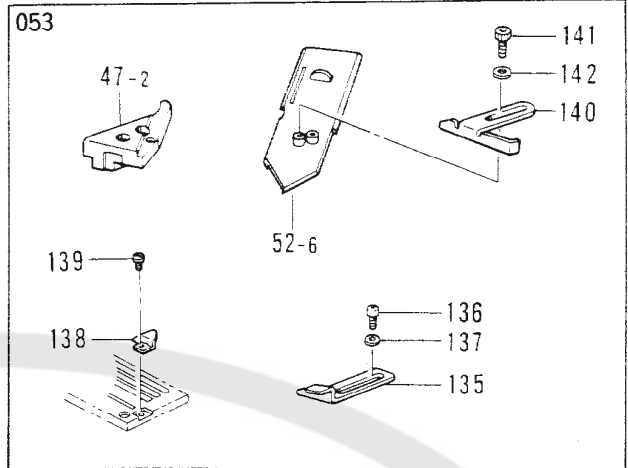
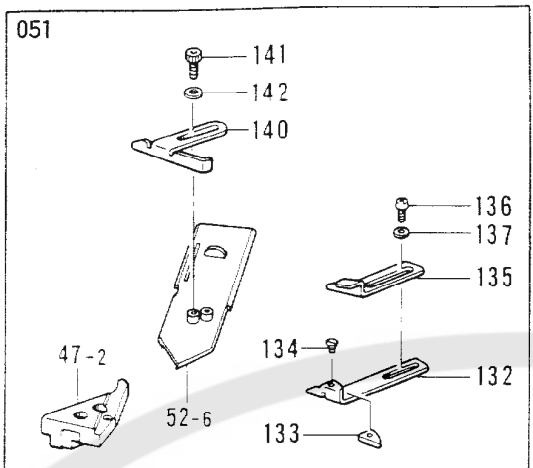

A2. 主体関係 / Machine body / Maschinengehäuse /
Corps de la machine / Cuerpo de la máquina

REF.NO.	CODE	Q'TY	ヒンメイ	NAME OF PARTS	RM
			<051>		
47-2	S28766001	1	クロスプレートSB	CLOTH PLATE (SB)	
52-6	S28024001	1	スベリイタD	SLIDE PLATE (D)	
132	S28054001	1	ヘムヌイガイドL	HEM SEWING GUIDE (L)	
133	S28055001	1	ガイドチップ	GUIDE TIP	
134	100360003	1	サラネジ2.38	SCREW, FLAT M2.38	
135	S28056001	1	ヘムヌイガイドR	HEM SEWING GUIDE (R)	
136	062711212	2	ナベコ476-32X12	SCREW, PAN M4.76-32X12	
137	113431002	2	ザガネ	WASHER	
140	S28500001	1	ヌノガイドRA	CLOTH GUIDE (RA)	
141	018680822	2	アナボルト4.37X8	BOLT, SOCKET M4.37X8	
142	100645003	2	ザガネ	WASHER	
			<053>		
47-2	S28766001	1	クロスプレートSB	CLOTH PLATE (SB)	
52-6	S28024001	1	スベリイタD	SLIDE PLATE (D)	
135	S28056001	1	ヘムヌイガイドR	HEM SEWING GUIDE (R)	
136	062711212	2	ナベコ476-32X12	SCREW, PAN M4.76-32X12	
137	113431002	2	ザガネ	WASHER	
138	S28822001	1	ヘムヌイガイドS	HEM SEWING GUIDE (S)	
139	S01295001	1	シメネジ2.38X3.5	SCREW, M2.38X3.5	
140	S28500001	1	ヌノガイドRA	CLOTH GUIDE (RA)	
141	018680822	2	アナボルト4.37X8	BOLT, SOCKET M4.37X8	
142	100645003	2	ザガネ	WASHER	
			<061>		
2-2	S12703001	1	ウワフタ	TOP COVER	
30	159150009	1	カマジクメクラセン	OIL CAP	
37-2	062681012	6	ナベコ437-40X10	SCREW, PAN M4.37-40X10	
47-2	S28766001	1	クロスプレートSB	CLOTH PLATE (SB)	
52-3	S28021001	1	スベリイタB	SLIDE PLATE (B)	
128	S28052001	1	ガイドL	GUIDE (L)	
129	S28053001	1	ガイドR	GUIDE (R)	
130	110072001	2	シメネジ4.76	SCREW, M4.76	
			<0X1>		
47-2	S28766001	1	クロスプレートSB	CLOTH PLATE (SB)	
52-6	S28024001	1	スベリイタD	SLIDE PLATE (D)	
55-4	S28030001	1	マエカバーC	FRONT COVER (C)	
68-3	S28060001	1	ホジヨイタ	SUPPORT PLATE	
88-2	S28042001	1	ヨコカバーウワイタB	SIDE COVER UPPER PLATE (B)	
200	S28054001	1	ヘムヌイガイドL	HEM SEWING GUIDE (L)	
201	S28055001	1	ガイドチップ	GUIDE TIP	
202	100360003	1	サラネジ2.38	SCREW, FLAT M2.38	
203	S28056001	1	ヘムヌイガイドR	HEM SEWING GUIDE (R)	
204	062680612	2	ナベコ4.37-40X6	SCREW, PAN M4.37-40X6	
205	100645003	2	ザガネ	WASHER	
206	S28059101	1	ホジヨアンナイ	SUB GUIDE	
207	062680512	1	ナベコ437-40X5	SCREW, PAN M4.37-40X5	
208	S28523001	1	ヌノガイドRB	CLOTH GUIDE (RB)	
209	018680822	2	アナボルト4.37X8	BOLT, SOCKET M4.37X8	
210	100645003	2	ザガネ	WASHER	
211	S28831001	1	ホジヨイタバネ	SUPPORT PLATE SPRING	
212	100105005	2	シメネジ2.38	SCREW, M2.38	
			<033>		
128	S28052001	1	ガイドL	GUIDE (L)	
129	S28053001	1	ガイドR	GUIDE (R)	
130	110072001	2	シメネジ4.76	SCREW, M4.76	

A3. 主体関係 / Machine body / Maschinengehäuse /
Corps de la machine / Cuerpo de la máquina

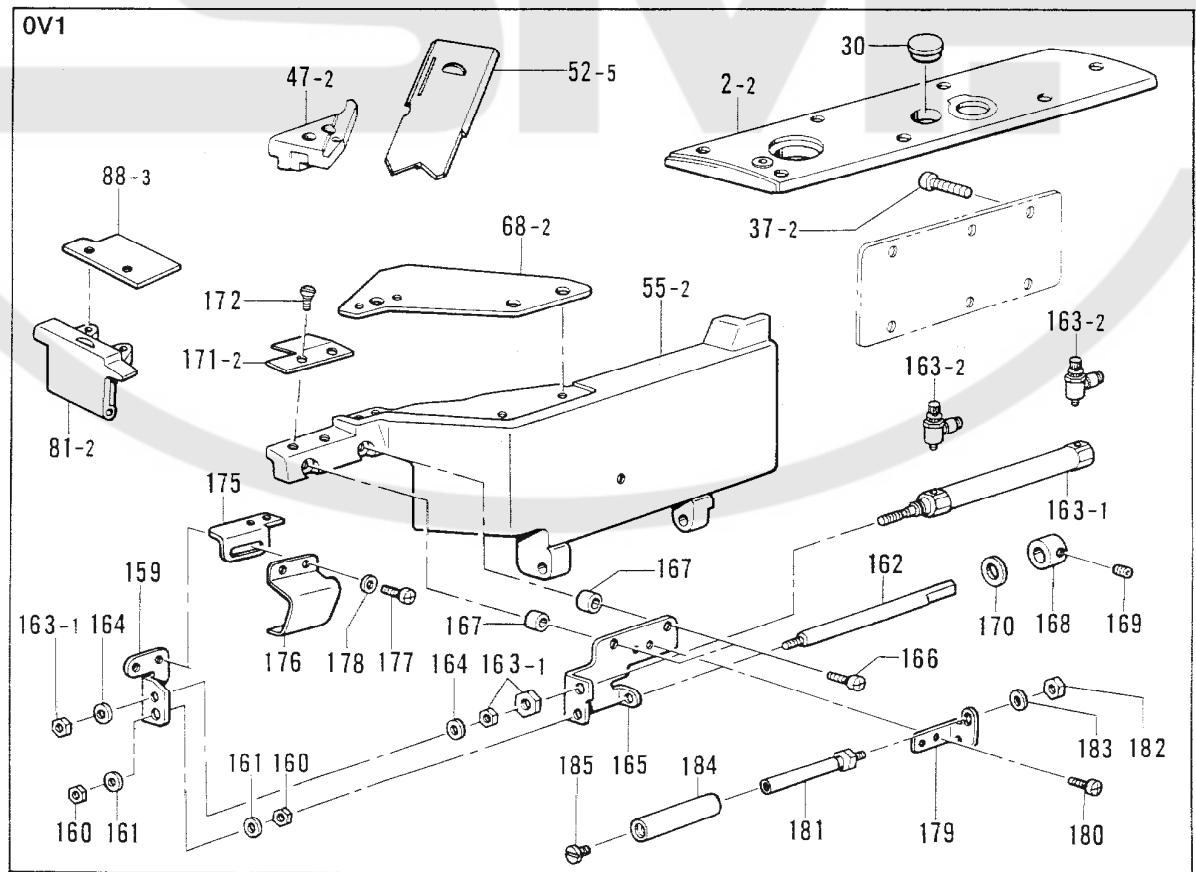
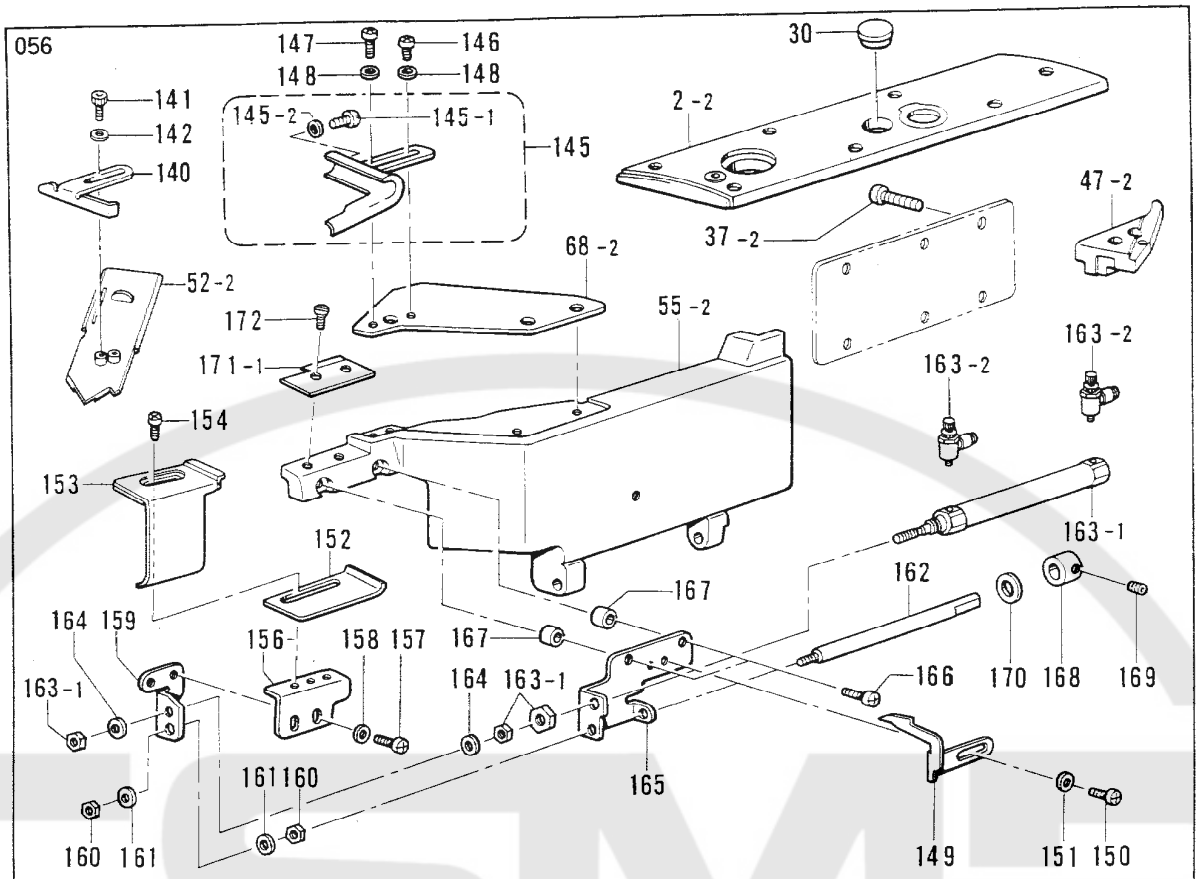

A3. 主体関係 / Machine body / Maschinengehäuse /
Corps de la machine / Cuerpo de la máquina

REF.NO.	CODE	Q'TY	ヒンメイ	NAME OF PARTS	RM
			<056,0V1>		
2-2	S12703001	1	ウワフタ	TOP COVER	
30	159150009	1	カマジクメクラセン	OIL CAP	
37-2	062681012	6	ナベコ437-40X10	SCREW, PAN M4.37-40X10	
47-2	S28766001	1	クロスプレートSB	CLOTH PLATE (SB)	
55-2	S28495001	1	マエカバーD	FRONT COVER (D)	
68-2	S28815001	1	ホジヨイタC	SUPPORT PLATE (C)	
159	S28506001	1	ゴムガイドドクドウイタ	RUBBER GUIDE DRIVING PLATE	
160	021500106	2	1シユナツト5	NUT, 1 M5	
161	025050236	2	ヒラザガネチユウ-5	WASHER, PLAIN M 5	
162	S28507000	1	ガイドジク	GUIDE SHAFT	
163	S28508000	1	エアーシリンダクミ	AIR CYLINDER ASSY	
163-1	S28509000	1	エアーシリンダ	AIR CYLINDER	
163-2	S23671000	2	スピードコントローラ	SPEED CONTROLLER	
164	025040236	2	ヒラザガネチユウ4	WASHER, PLAIN M4	
165	S28510001	1	シリンダドダイ	SYLINDER BRACKET	
166	062711612	2	ナベコ476-32X16	SCREW, PAN M4.76-32X16	
167	153195001	2	コロ	ROLLER	
168	147402001	1	セツトカラー	SET COLLAR	
169	014680422	1	アナトメネジ4.37クボミ	SET SCREW, SOCKET (CP) M4.37	
170	154599000	1	ソレノイドクツシヨン	SOLENOID CUSHION	
172	107272002	2	サラネジ4.37	SCREW, FLAT M4.37	
			<056>		
52-2	S28493001	1	スベリイタF	SLIDE PLATE (F)	
140	S28500001	1	ヌノガイドRA	CLOTH GUIDE (RA)	
141	018680822	2	アナボルト4.37X8	BOLT, SOCKET M4.37X8	
142	100645003	2	ザガネ	WASHER	
145	S28866001	1	バインダー-Rクミ	BINDER (R) ASSY	
145-1	062670412	2	ナベコ357-40X4	SCREW, PAN M3.57-40X4	
145-2	105161004	2	ザガネ	WASHER	
146	062710612	1	ナベコ476-32X6	SCREW, PAN M4.76-32X6	
147	062711212	1	ナベコ476-32X12	SCREW, PAN M4.76-32X12	
148	148847001	2	ザガネ	WASHER	
149	S28502001	1	ヌノガイドL	CLOTH GUIDE (L)	
150	062680812	2	ナベコ437-40X8	SCREW, PAN M4.37-40X8	
151	100645003	2	ザガネ	WASHER	
152	S28503000	1	バインダー-L	BINDER (L)	
153	S28504000	1	ゴムガイド	RUBBER GUIDE	
154	060680712	2	バインド437-40X7	SCREW, BIND M4.37-40X7	
156	S28505001	1	ゴムガイドトリツケダイ	RUBBER GUIDE SET BRACKET	
157	062680812	2	ナベコ437-40X8	SCREW, PAN M4.37-40X8	
158	100645003	2	ザガネ	WASHER	
171-1	S28819001	1	スベリイタS	SLIDE PLATE (S)	
			<0V1>		
52-5	S28494001	1	スベリイタG	SLIDE PLATE (G)	
81-2	S28496001	1	ヨコカバーB	SIDE COVER (B)	
88-3	S28497001	1	ヨコカバーウイタC	SIDE COVER UPPER PLATE (C)	
171-2	S28818001	1	スベリイタS	SLIDE PLATE (S)	
175	S28515001	1	ジヨウギトリツケダイ	RULLER SET BASE	
176	S28516001	1	シリンダカバー	CYLINDER COVER	
177	062680812	2	ナベコ437-40X8	SCREW, PAN M4.37-40X8	
178	025680133	2	ヒラザガネシヨウ4.37	WASHER, PLAIN S 4.37	
179	S28517001	1	ホジヨローラササエ	SUB ROLLER SUPPORT	
180	062680812	2	ナベコ437-40X8	SCREW, PAN M4.37-40X8	
181	S28518001	1	ホジヨローラジク	SUB ROLLER SHAFT	
182	105234003	1	ナツト4.37	NUT, M4.37	
183	100645003	1	ザガネ	WASHER	
184	S28519000	1	ホジヨローラ	SUB ROLLER	
185	148834001	1	シメネジ3.57	SCREW, M3.57	

A4. 主体関係 / Machine body / Maschinengehäuse /
 Corps de la machine / Cuerpo de la máquina

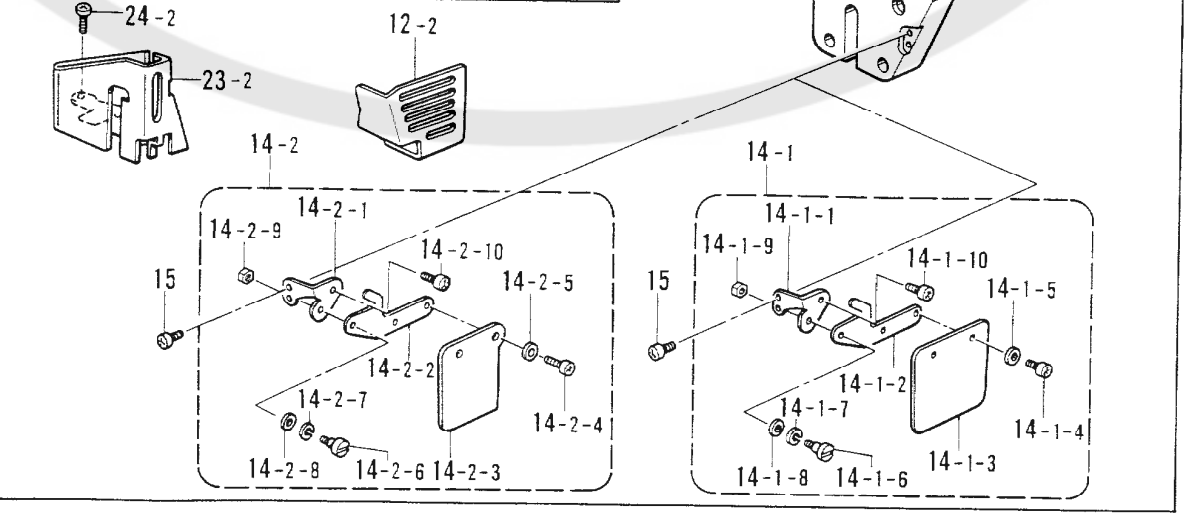
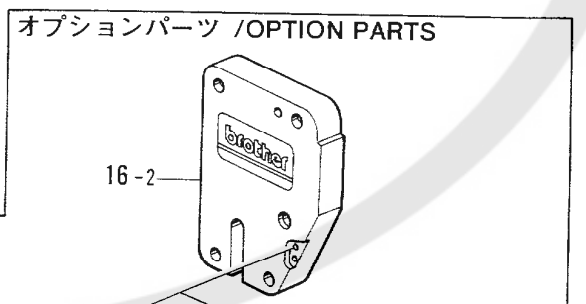
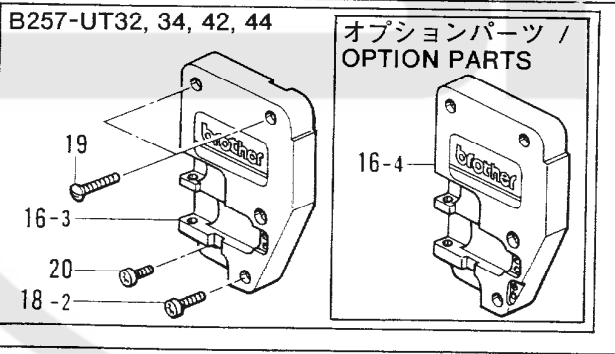
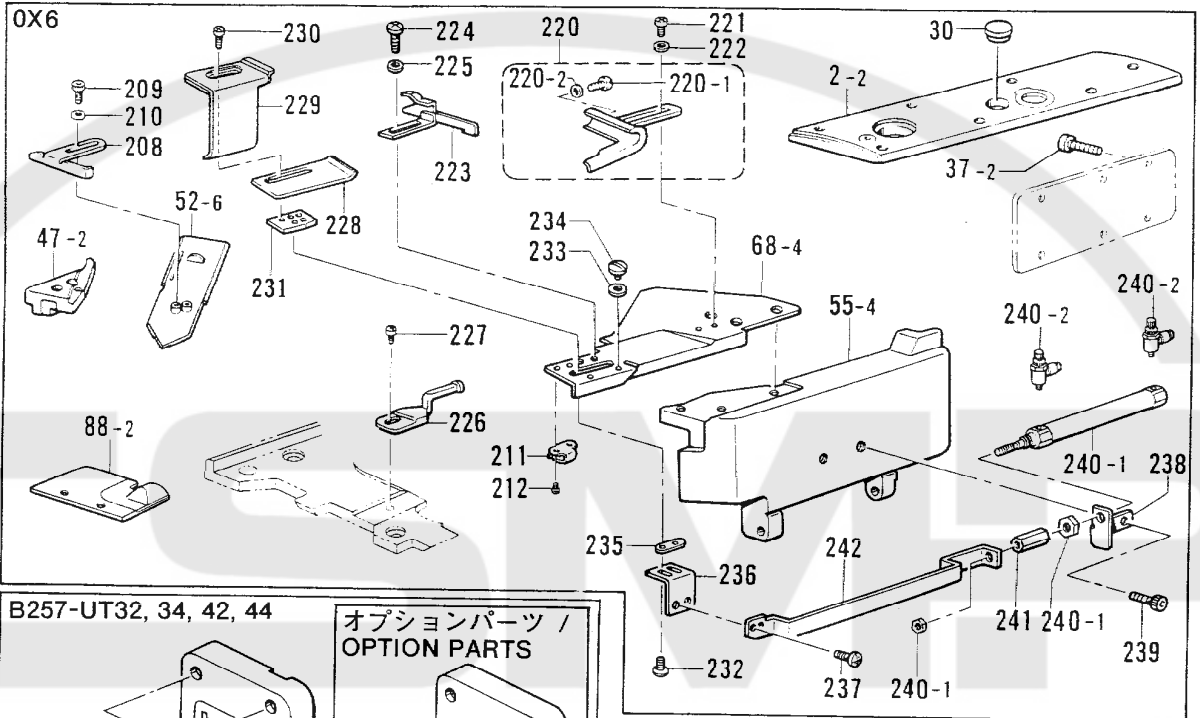
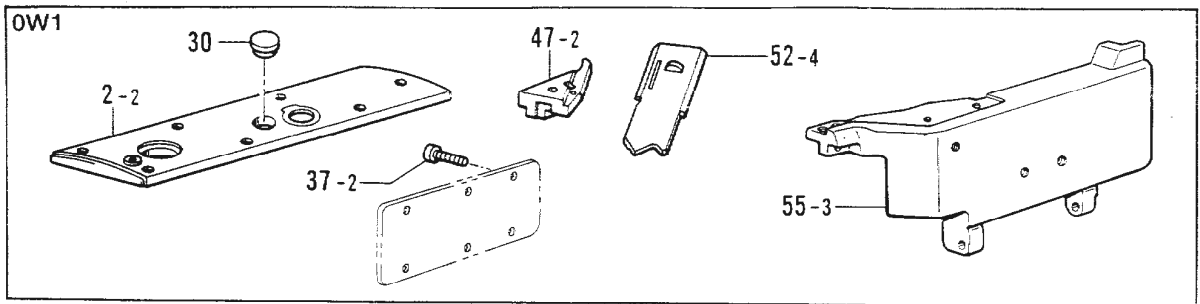

A4. 主体関係 / Machine body / Maschinengehäuse /
Corps de la machine / Cuerpo de la máquina

REF.NO.	CODE	Q'TY	ヒンメイ	NAME OF PARTS	RM
			<0W1>		
2-2	S12703001	1	ウワフタ	TOP COVER	
30	159150009	1	カマジクメクラセン	OIL CAP	
37-2	062681012	6	ナベコ437-40X10	SCREW, PAN M4.37-40X10	
47-2	S28766001	1	クロスプレートSB	CLOTH PLATE (SB)	
52-4	S28022001	1	スベリイタC	SLIDE PLATE (C)	
55-3	S28029001	1	マエカバーB	FRONT COVER (B)	
			<0X6>		
2-2	S12703001	1	ウワフタ	TOP COVER	
30	159150009	1	カマジクメクラセン	OIL CAP	
37-2	062681012	6	ナベコ437-40X10	SCREW, PAN M4.37-40X10	
47-2	S28766001	1	クロスプレートSB	CLOTH PLATE (SB)	
52-6	S28024001	1	スベリイタD	SLIDE PLATE (D)	
55-4	S28030001	1	マエカバーC	FRONT COVER (C)	
68-4	S28521001	1	ホジヨイタ	SUPPORT PLATE	
88-2	S28042001	1	ヨコカバーウワイタB	SIDE COVER UPPER PLATE (B)	
208	S28523001	1	ヌノガイドRB	CLOTH GUIDE (RB)	
209	018680822	2	アナボルト4.37X8	BOLT, SOCKET M4.37X8	
210	100645003	2	ザガネ	WASHER	
211	S28831001	1	ホジヨイタバネ	SUPPORT PLATE SPRING	
212	100105005	2	シメネジ2.38	SCREW, M2.38	
220	S28867001	1	バインダーRクミ	BINDER (R) ASSY	
220-1	062670412	2	ナベコ357-40X4	SCREW, PAN M3.57-40X4	
220-2	105161004	2	ザガネ	WASHER	
221	062680512	2	ナベコ437-40X5	SCREW, PAN M4.37-40X5	
222	100645003	2	ザガネ	WASHER	
223	S28525000	1	ヌノガイドL	CLOTH GUIDE (L)	
224	062680512	2	ナベコ437-40X5	SCREW, PAN M4.37-40X5	
225	100645003	2	ザガネ	WASHER	
226	S28059101	1	ホジヨアンナイ	SUB GUIDE	
227	062680512	1	ナベコ437-40X5	SCREW, PAN M4.37-40X5	
228	S28503000	1	バインダーL	BINDER (L)	
229	S28504000	1	ゴムガイド	RUBBER GUIDE	
230	060680712	2	バインド437-40X7	SCREW, BIND M4.37-40X7	
231	S28526001	1	ゴムガイドトリツケダイ	RUBBER GUIDE SET BRACKET	
232	062680812	2	ナベコ437-40X8	SCREW, PAN M4.37-40X8	
233	146354001	2	ザガネ	WASHER	
234	105130001	2	シメネジ3.57	SCREW, M3.57	
235	S28527001	1	トリツケダイスベリイタ	BRACKET SLIDE PLATE	
236	S28528001	1	ゴムガイドクドウイタ	RUBBER GUIDE DRIVING PLATE	
237	062680612	2	ナベコ4.37-40X6	SCREW, PAN M4.37-40X6	
238	S28529001	1	シリンダドダイ	CYLINDER BRACKET	
239	018501022	2	アナボルト5X10	BOLT, SOCKET M5X10	
240	S28508000	1	エアーシリンダクミ	AIR CYLINDER ASSY	
240-1	S28509000	1	エアーシリンダ	AIR CYLINDER	
240-2	S23671000	2	スピードコントローラ	SPEED CONTROLLER	
241	S28532001	1	ナツト	NUT	
242	S28533001	1	ガイドカイヘイレカン	GUIDE OPENING AND CLOSING CONNECTOR	

A4. 主体関係 / Machine body / Maschinengehäuse /
 Corps de la machine / Cuerpo de la máquina

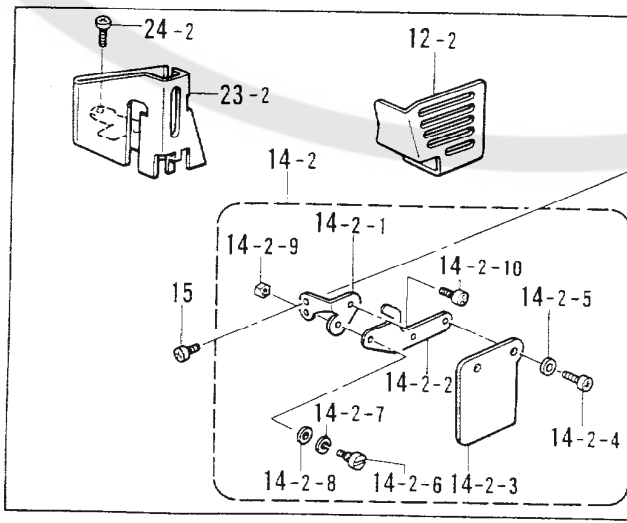
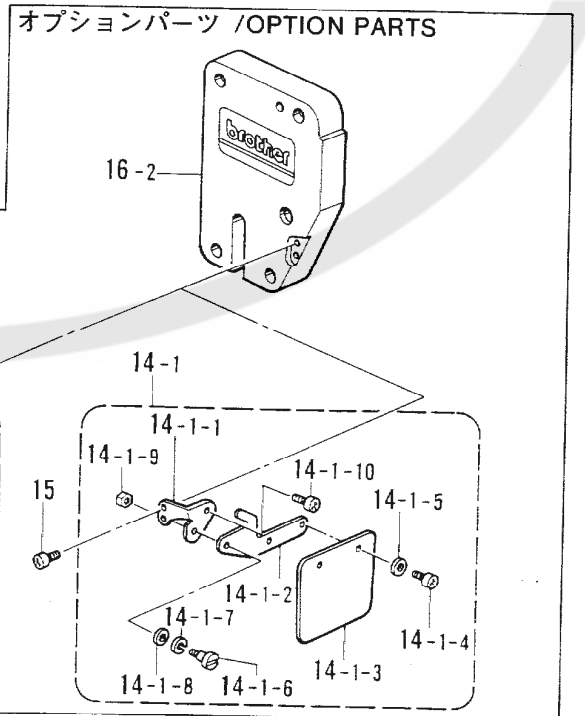
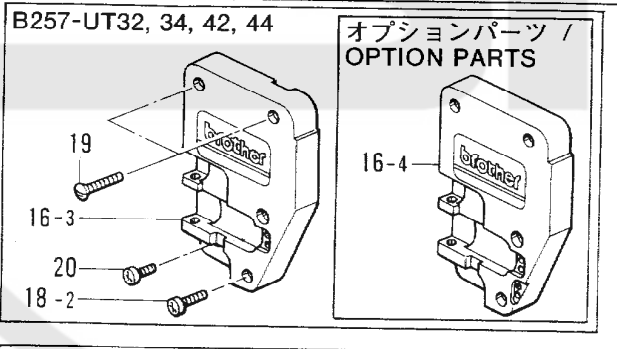
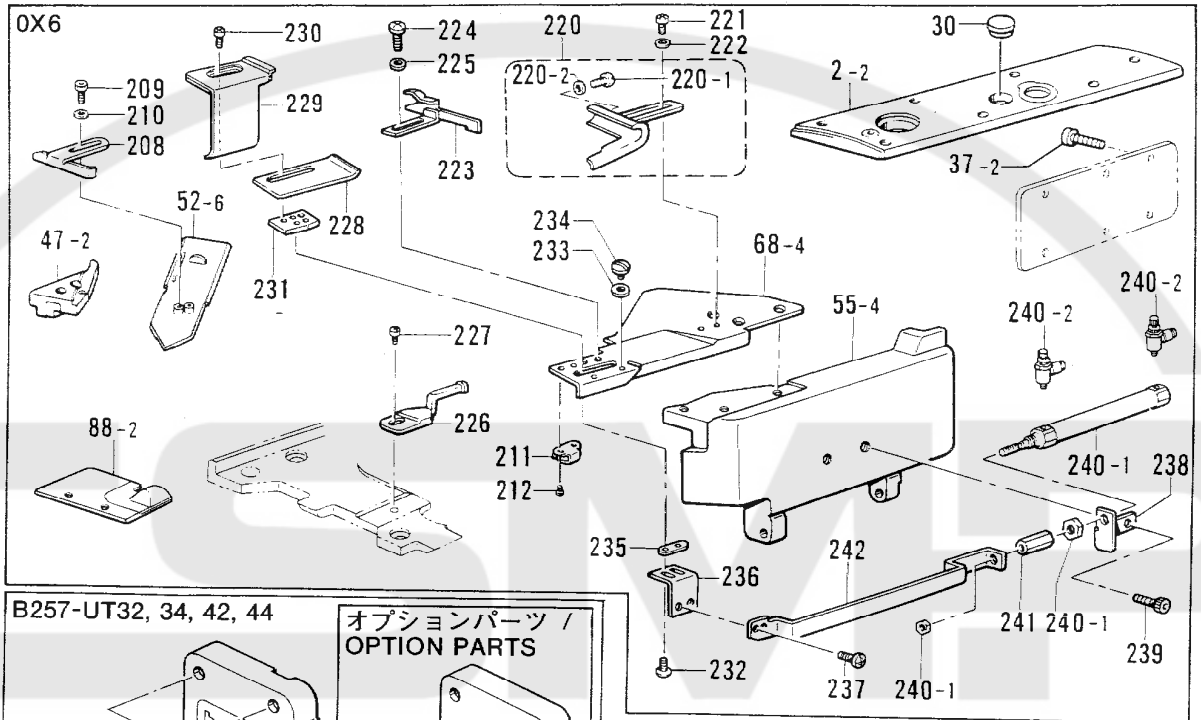
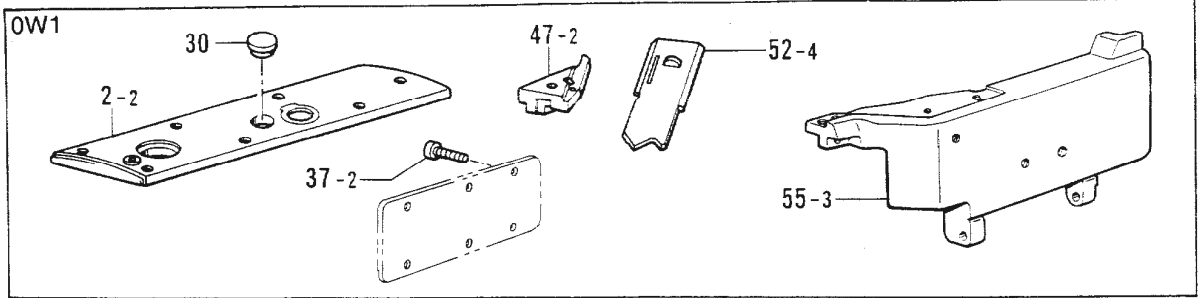

A4. 主体関係 / Machine body / Maschinengehäuse /
Corps de la machine / Cuerpo de la máquina

REF.NO.	CODE	Q'TY	ヒンメイ	NAME OF PARTS	RM
<B257-UT32,34,42,44>					
16-3	S21960001	1	メンイタ	FACE PLATE	
18-2	062681612	1	ナベコ437-40X16	SCREW, PAN M4.37-40X16	
19	156937001	2	マルサラネジ4.37X25	SCREW, FLAT M4.37X25	
20	062681012	1	ナベコ437-40X10	SCREW, PAN M4.37-40X10	
<オプションパーツ / OPTION PARTS>					
16-4	S28811001	1	メンイタ	FACE PLATE	
<オプションパーツ / OPTION PARTS>					
12-2	S28807001	1	ハライトクリカバー	NEEDLE THREAD TAKE-UP COVER	
14-1	S28802001	1	アイガードクミ	EYE GUARD ASSY	
14-1-1	S28803001	1	アイガードドダイ	EYE GUARD BASE	
14-1-2	S28804001	1	アイガードトリツケイタ	EYE GUARD SET PLATE	
14-1-3	S00075000	1	アイガード	EYE GUARD	
14-1-4	062660512	2	ナベコネジ318-40X5	SCREW, PAN M3.18-40X5	
14-1-5	025030232	2	ヒラザガネチユウ3	WASHER, PLAIN M 3	
14-1-6	S07317001	1	ダンネジ3.57	STUD SCREW, M3.57	
14-1-7	028050246	1	バネザガネ2-5	WASHER, SPRING 2-5	
14-1-8	025050232	1	ヒラザガネチユウ5	WASHER, PLAIN M 5	
14-1-9	106129001	1	ナツト3.57	NUT, M3.57	
14-1-10	060670512	1	バインド357-40X5	SCREW, BIND M3.57-40X5	
14-2	S28805001	1	アイガードクミ	EYE GUARD ASSY	
14-2-1	S28803001	1	アイガードドダイ	EYE GUARD BASE	
14-2-2	S28804001	1	アイガードトリツケイタ	EYE GUARD SET PLATE	
14-2-3	S28806000	1	アイガード	EYE GUARD	
14-2-4	062660512	2	ナベコネジ318-40X5	SCREW, PAN M3.18-40X5	
14-2-5	025030232	2	ヒラザガネチユウ3	WASHER, PLAIN M 3	
14-2-6	S07317001	1	ダンネジ3.57	STUD SCREW, M3.57	
14-2-7	028050246	1	バネザガネ2-5	WASHER, SPRING 2-5	
14-2-8	025050232	1	ヒラザガネチユウ5	WASHER, PLAIN M 5	
14-2-9	106129001	1	ナツト3.57	NUT, M3.57	
14-2-10	060670512	1	バインド357-40X5	SCREW, BIND M3.57-40X5	
15	060680712	2	バインド437-40X7	SCREW, BIND M4.37-40X7	
16-2	S28810001	1	メンイタ	FACE PLATE	
23-2	S28809001	1	ハリボウテンピンカバー	NEEDLE BAR TAKE-UP COVER	
24-2	060680712	2	バインド437-40X7	SCREW, BIND M4.37-40X7	

B. 上軸・針棒関係 / Upper shaft and needle bar mechanism / Obere Welle und Nadelstangenvorrichtung / Mécanisme de arbre supérieur et barra à aiguille / Mecanismo del eje superior y la barra de aguja

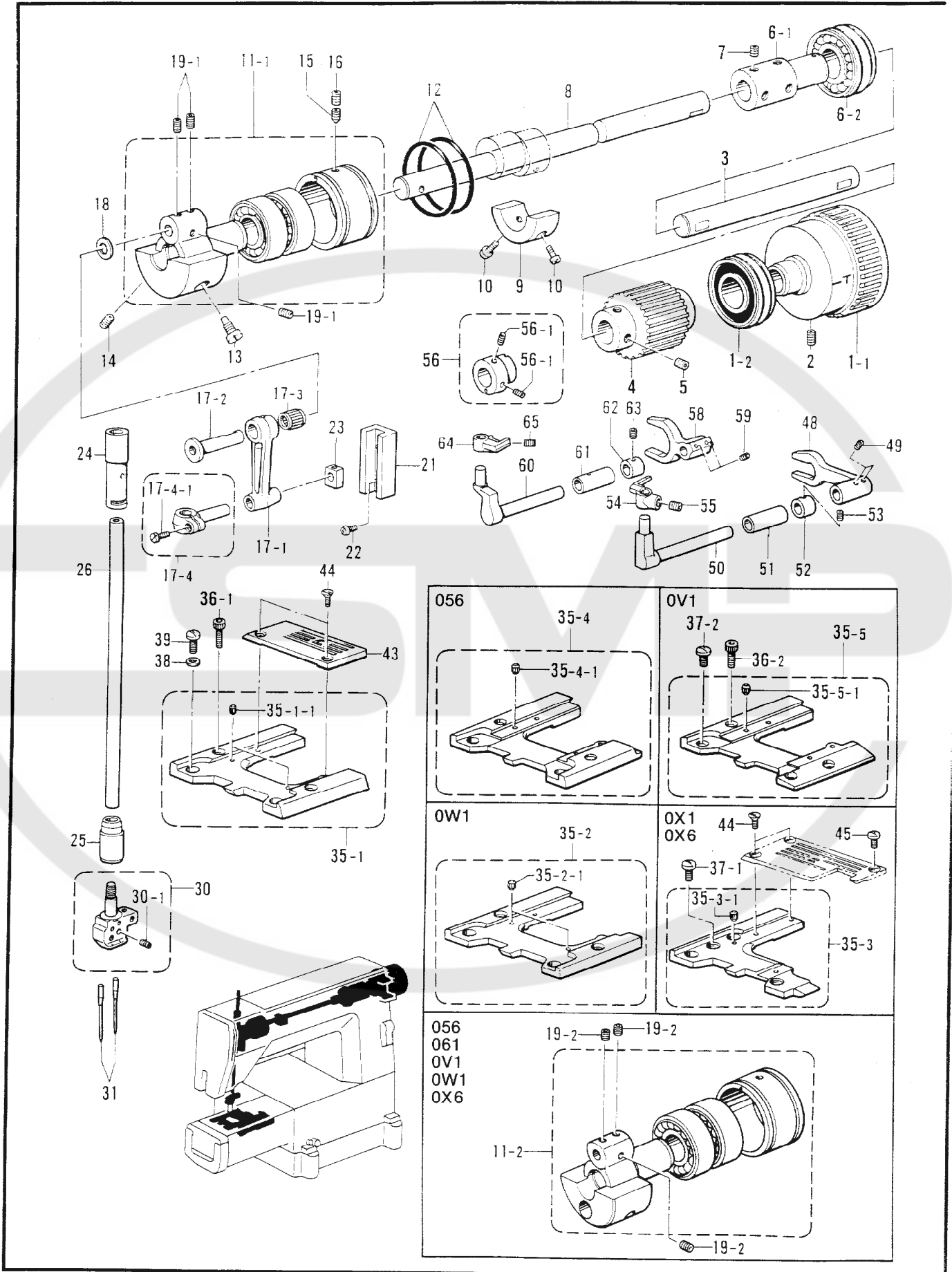

B. 上軸・針棒関係 / Upper shaft and needle bar mechanism / Obere Welle und Nadelstangenvorrichtung / Mécanisme de arbre supérieur et barra à aiguille / Mecanismo del eje superior y la barra de aguaja

REF.NO.	CODE	Q'TY	ヒンメイ	NAME OF PARTS	RM
1	S28069009	1	プーリクミ	PULLEY ASSY	
1-1	S28070009	1	プーリ	PULLEY	
1-2	S14621001	1	タマジクウケ6204LLB	BALL BEARING, 6204LLB	
2	014770622	2	アナトメネジ6.35クボミ	SET SCREW, SOCKET (CP) M6.35	
3	S08682001	1	ウワジクR	UPPER SHAFT (R)	
4	S08683000	1	タイミングプーリU	TIMING PULLEY (U)	
5	014770622	4	アナトメネジ6.35クボミ	SET SCREW, SOCKET (CP) M6.35	
6	S08684101	1	ツギテLクミ	JOINT (L) ASSY	
6-1	S08685001	1	ツギテL	JOINT (L)	
6-2	S08686101	1	タマジクウケ6204LU	BALL BEARING, 6204LU	
7	014770622	4	アナトメネジ6.35クボミ	SET SCREW, SOCKET (CP) M6.35	
8	S12724001	1	ウワジクL	UPPER SHAFT (L)	
9	S08688001	1	ウエイト	WEIGHT	
10	062711012	2	ナベコ476-32X10	SCREW, PAN M4.76-32X10	
11-1	S28068001	1	ハリボウ克蘭クミ	NEEDLE BAR CRANK ASSY	
12	081046870	2	OリングS46	O RING, S46	
13	104464001	1	シメネジ7.14	SCREW, M7.14	
14	014770622	1	アナトメネジ6.35クボミ	SET SCREW, SOCKET (CP) M6.35	
15	118853001	1	アナトメネジ5.95	SET SCREW, SOCKET M5.95	
16	014760622	1	アナトメネジ5.95	SET SCREW, SOCKET (CP) M5.95	
17	S08692101	1	ハリボウレンカンクミ	THREAD TAKE-UP LEVER ASSY	
17-1	S08693001	1	ハリボウレンカン	THREAD TAKE-UP LEVER	
17-2	S08694001	1	ハリボウレンカンジク	THREAD TAKE-UP LEVER SHAFT	
17-3	S09120001	1	ニードルジクウケ	NEEDLE ROLLER BEARING	
17-4	S30086001	1	ハリボウダキクミ	NEEDLE BAR CLAMP ASSY	
17-4-1	100064005	1	シメネジ3.57	SCREW, M3.57	
18	107153001	1	ザガネ	WASHER	
19-1	014760622	3	アナトメネジ5.95	SET SCREW, SOCKET (CP) M5.95	
21	145688000	1	ハリボウアンナイ	NEEDLE BAR GUIDE	
22	062670612	2	ナベコ357-40X6	SCREW, PAN M3.57-40X6	
23	102630001	1	ハリボウアンナイカクコマ	NEEDLE BAR GUIDE SLIDE BLOCK	
24	S08696000	1	ハリボウメタルU	NEEDLE BAR BUSH (U)	
25	S08697000	1	ハリボウメタルD	NEEDLE BAR BUSH (D)	
26	S08698001	1	ハリボウ	NEEDLE BAR	
30	※	1	ハリドメクミ	NEEDLE CLAMP ASSY	
35-1	S28063001	1	ハリイタササエイタクミ	NEEDLE PLATE SUPPORT (A) ASSY	
35-1-1	S28064001	2	ミゾツキピン	PIN	
36-1	018681022	2	アナボルト4.37X10	BOLT, SOCKET M4.37X10	
38	S28075001	2	ハリイタササエイタカラー	COLLAR	
39	060670812	2	バインド357-40X8	SCREW, BIND M3.57-40X8	
43	※	1	ハリイタ	NEEDLE PLATE	
44	S09121001	2	マルサラネジ3.57X6	SCREW, FLAT M3.57X6	
48	S28087001	1	ハリウケフレバー	NEEDLE GUARD (F) LEVER	
49	014680422	2	アナトメネジ4.37クボミ	SET SCREW, SOCKET (CP) M4.37	
50	S28088001	1	ハリウケFホルダ	NEEDLE GUARD (F) HOLDER	
51	S28096000	1	ハリウケホルダメタル	NEEDLE GUARD HOLDER BUSH	
52	S28090001	1	セツトカラー	SET COLLAR	
53	014680422	1	アナトメネジ4.37クボミ	SET SCREW, SOCKET (CP) M4.37	
54	S28091001	1	ハリウケF	NEEDLE GUARD (F)	
55	014680422	1	アナトメネジ4.37クボミ	SET SCREW, SOCKET (CP) M4.37	
56	S28092001	1	ハリウケBヘンシンリンクミ	NEEDLE GUARD (B) ECCENTRIC WHEEL ASSY	
56-1	014680422	2	アナトメネジ4.37クボミ	SET SCREW, SOCKET (CP) M4.37	
58	S28094001	1	ハリウケBレバー	NEEDLE GUARD (B) LEVER	
59	014680422	2	アナトメネジ4.37クボミ	SET SCREW, SOCKET (CP) M4.37	
60	S28095001	1	ハリウケBホルダ	NEEDLE GUARD (B) HOLDER	
61	S28096000	1	ハリウケホルダメタル	NEEDLE GUARD HOLDER BUSH	
62	S28090001	1	セツトカラー	SET COLLAR	
63	014680422	1	アナトメネジ4.37クボミ	SET SCREW, SOCKET (CP) M4.37	
64	S28097001	1	ハリウケB	NEEDLE GUARD (B)	
65	014680422	1	アナトメネジ4.37クボミ	SET SCREW, SOCKET (CP) M4.37	

B. 上軸・針棒関係 / Upper shaft and needle bar mechanism / Obere Welle und Nadelstangenvorrichtung / Mécanisme de arbre supérieur et barra à aiguille / Mecanismo del eje superior y la barra de aguja

REF.NO.	CODE	Q'TY	品名	NAME OF PARTS	RM
30-1 31	146427001 S08715010	2 2	<-1,-2,-3,-4,-5> アナトメネジ3.18クボミ ミシンハリUYX128GAS	SET SCREW, SOCKET (CP) M3.18 NEEDLE UYX128GAS	
30-1 31	146427001 S08715010	3 3	<-6,-7,-8> アナトメネジ3.18クボミ ミシンハリUYX128GAS	SET SCREW, SOCKET (CP) M3.18 NEEDLE UYX128GAS	
11-2 19-2	S12725101 152718001	1 3	<056,061,0V1,0W1,0X6> ハリボウクランククミ アナトメネジ5.95	NEEDLE BAR CRANK ASSY SET SCREW, SOCKET M5.95	
35-2 35-2-1	S28065001 S28064001	1 2	<0W1> ハリイタササエイタBクミ ミゾツキピン	NEEDLE PLATE SUPPORT (B) ASSY PIN	
35-3 35-3-1 37-1 44 45	S28066001 S28064001 153208002 S09121001 100257010	1 1 2 2 1	<0X1,0X6> ハリイタササエイタDクミ ミゾツキピン シメネジ4.37 マルサラネジ3.57X6 シメネジ3.57	NEEDLE PLATE SUPPORT (D) ASSY PIN SCREW, M4.37 SCREW, FLAT M3.57X6 SCREW, M3.57	
35-4 35-4-1	S28512001 S28064001	1 2	<056> ハリイタササエイタEクミ ミゾツキピン	NEEDLE PLATE SUPPORT (E) ASSY PIN	
35-5 35-5-1 36-2 37-2	S28513001 S28064001 018681022 153208002	1 2 1 1	<B257-0V1> ハリイタササエイタFクミ ミゾツキピン アナボルト4.37X10 シメネジ4.37	NEEDLE PLATE SUPPORT (F) ASSY PIN BOLT, SOCKET M4.37X10 SCREW, M4.37	

C1. 押工関係 / Presser foot mechanism / Stoffdrückerfuß /
 Mécanisme de pied presseur / Mecanismo de la prensa tela

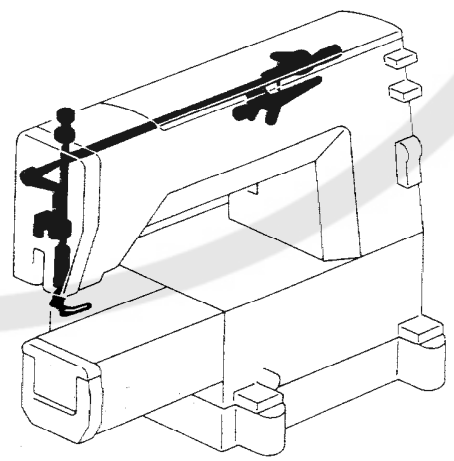
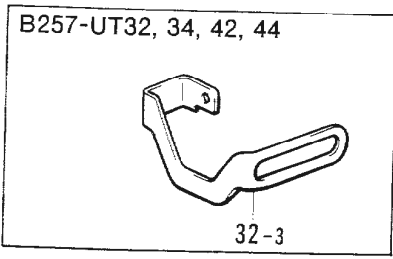
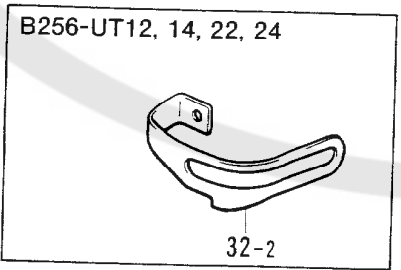
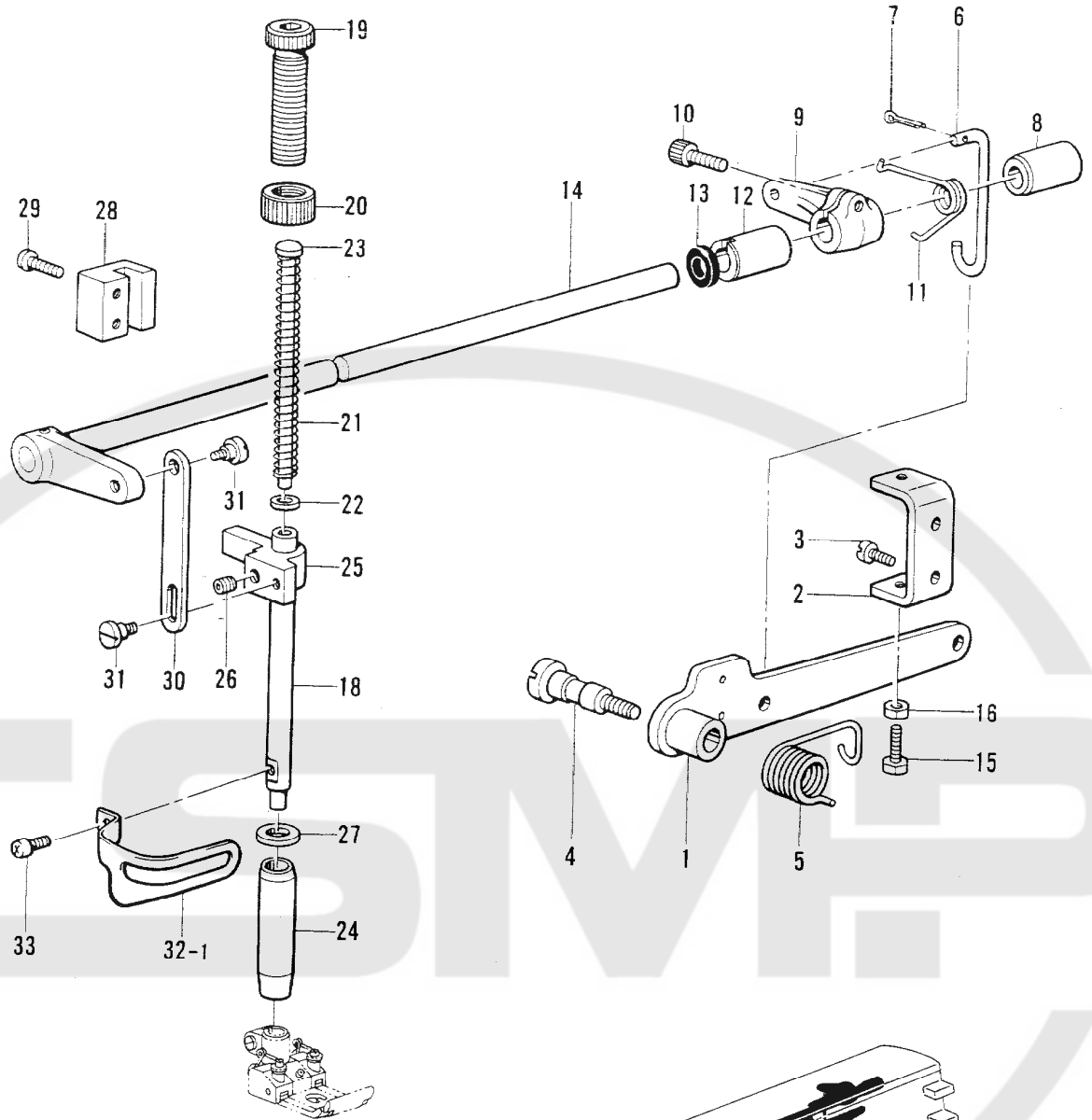

C1. 押工関係 / Presser foot mechanism / Stoffdrückerfuß /
 Mécanisme de pied presseur / Mecanismo de la prensa tela

REF.NO.	CODE	Q'TY	品名	NAME OF PARTS	RM
1	S21829001	1	オサエアゲレバーR	PRESSER BAR LIFTER LEVER (R)	
2	146522101	1	レバーチヨウセツイタ	LEVER ADJUST PLATE	
3	060680712	2	バインド437-40X7	SCREW, BIND M4.37-40X7	
4	S21830001	1	ダンネジ7.94	STUD SCREW, M7.94	
5	143325001	1	オサエアシアゲレバーバネ	SPRING	
6	S08769001	1	オサエアゲリンク	PRESSER BAR LIFTER LINK	
7	110793001	1	ワリピン	PIN, COTTER	
8	155220000	1	ホジヨアツメタルR	AUTO PRESSER ARM BUSH (R)	
9	154956001	1	オサエアシアゲMレバー	PRESSER FOOT LIFTER INSIDE LEVER	
10	018771432	1	アナボルト635-40X14	BOLT, SOCKET M6.35-40X14	
11	154957001	1	オサエアゲMレバーバネ	SPRING	
12	S08770000	1	ジクメタル	SHAFT BUSH	
13	155539000	1	ダストシール	DUJST SEAL	
14	S08771001	1	オサエアゲレバーLクミ	PRESSER BAR LIFTER LEVER (L) ASSY	
15	017711612	1	ボルト4.76X16	BOLT, M4.76X16	
16	110161006	1	ナツト4.76	NUT, M4.76	
18	S08774001	1	オサエボウ	PRESSER BAR	
19	S31012001	1	オサエチヨウセツネジ	ADJUST SCREW	
20	S31013001	1	チヨウセツネジツツマミナツト	NUT	
21	141728001	1	オサエバネ	SPRING	
22	140407001	1	ザガネ	WASHER	
23	141208001	1	オサエバネアンナイ	SPRING GUIDE	
24	145472001	1	オサエボウメタル	PRESSER BAR BUSH	
25	S00879001	1	オサエボウダキ	PRESSER BAR CLAMP	
26	014760622	1	アナトメネジ5.95	SET SCREW, SOCKET (CP) M5.95	
27	154596000	1	イトキリカムレバークツション	CUSHION	
28	S08775000	1	オサエボウアンナイ	PRESSER BAR GUIDE	
29	062681412	2	ナベコ437-40X14	SCREW, PAN M4.37-40X14	
30	S08776001	1	オサエアゲイタ	PRESSER BAR LIFTER PLATE	
31	S08777001	2	ダンネジ4.37	STUD SCREW, M4.37	
32-1	S28798001	1	フィンガーガードA	FINGER GUARD (A)	
33	062670812	1	ナベコ3.57-40X8	SCREW, PAN M3.57-40X8	
32-2	S28800001	1	<B256-UT12,14,22,24> フィンガーガードC	FINGER GUARD (C)	
32-3	S28801001	1	<B257-UT32,34,42,44> フィンガーガードB	FINGER GUARD (B)	

C2. 押工関係 / Presser foot mechanism / Stoffdrückerfuß /
 Mécanisme de pied presseur / Mecanismo de la prensa tela

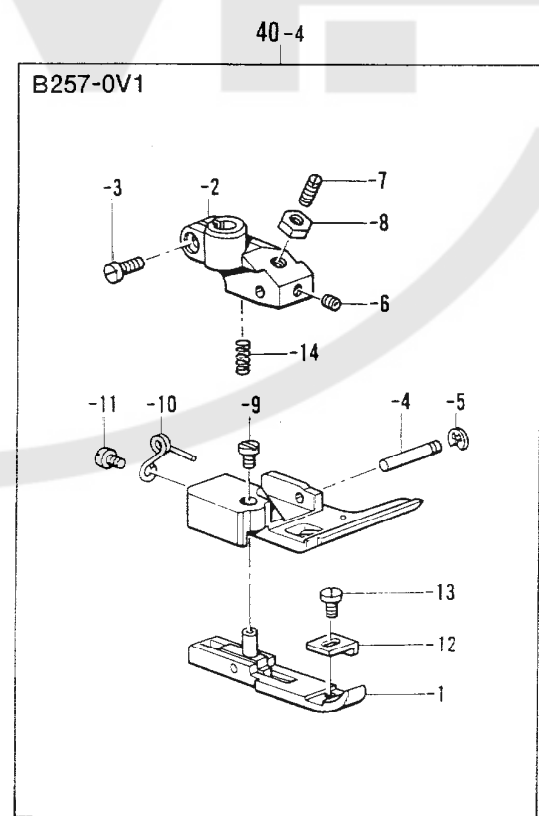
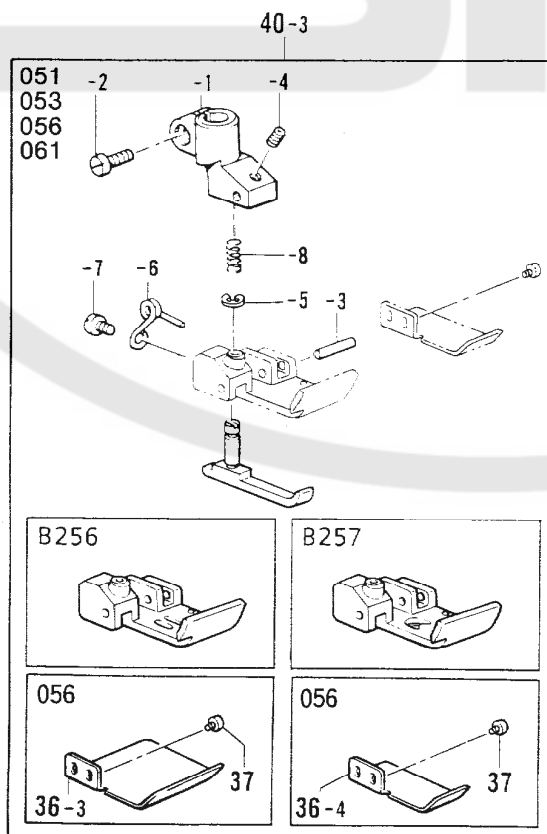
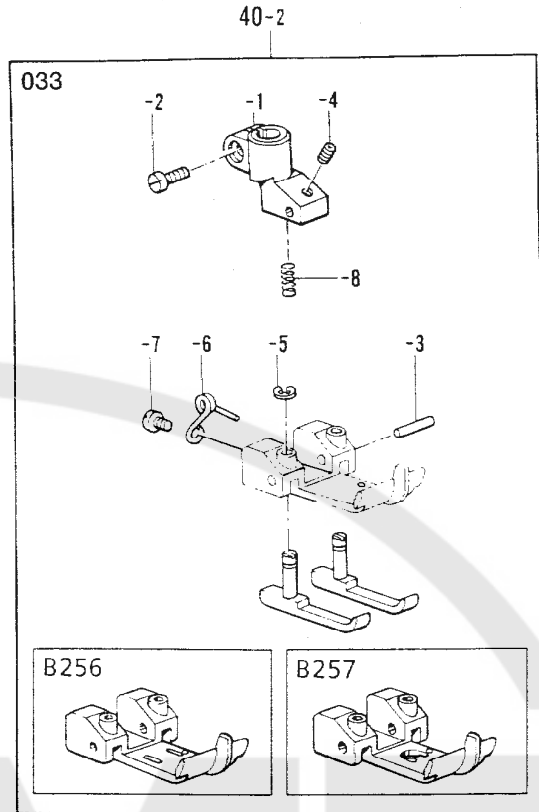
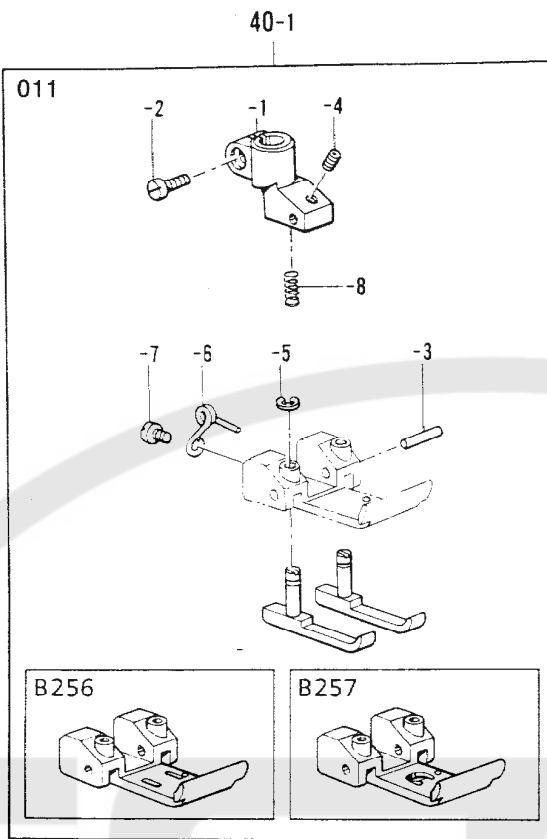

C2. 押工関係 / Presser foot mechanism / Stoffdrückerfuß /
 Mécanisme de pied presseur / Mecanismo de la prensa tela

REF.NO.	CODE	Q'TY	品名	NAME OF PARTS	RM
<011>					
40-1	※	1	オサエクミ	PRESSER FOOT ASSY	
40-1-1	S08782101	1	オサエシジタイ	PRESSER FOOT BASE	
40-1-2	100064005	1	シメネジ3.57	SCREW, M3.57	
40-1-3	S08783101	1	オサエピン	PIN	
40-1-4	S01374001	1	トメネジ2.38クボミ	SET SCREW, (CP) M2.38	
40-1-5	048020342	2	トメワE2	RETAINING RING, E2	
40-1-6	S08784001	2	オサエバネ	SPRING	
40-1-7	062660512	2	ナベコネジ318-40X5	SCREW, PAN M3.18-40X5	
40-1-8	S08785001	1	オシバネ	SPRING	
<033>					
40-2	※	1	オサエクミ	PRESSER FOOT ASSY	
40-2-1	S08782101	1	オサエシジタイ	PRESSER FOOT BASE	
40-2-2	100064005	1	シメネジ3.57	SCREW, M3.57	
40-2-3	S08783101	1	オサエピン	PIN	
40-2-4	S01374001	1	トメネジ2.38クボミ	SET SCREW, (CP) M2.38	
40-2-5	048020342	2	トメワE2	RETAINING RING, E2	
40-2-6	S08784001	2	オサエバネ	SPRING	
40-2-7	062660512	2	ナベコネジ318-40X5	SCREW, PAN M3.18-40X5	
40-2-8	S08785001	1	オシバネ	SPRING	
<051,053,056,061>					
40-3	※	1	オサエクミ	PRESSER FOOT ASSY	
40-3-1	S08782101	1	オサエシジタイ	PRESSER FOOT BASE	
40-3-2	100064005	1	シメネジ3.57	SCREW, M3.57	
40-3-3	S08783101	1	オサエピン	PIN	
40-3-4	S01374001	1	トメネジ2.38クボミ	SET SCREW, (CP) M2.38	
40-3-5	048020342	1	トメワE2	RETAINING RING, E2	
40-3-6	S08784001	1	オサエバネ	SPRING	
40-3-7	062660512	1	ナベコネジ318-40X5	SCREW, PAN M3.18-40X5	
40-3-8	S08785001	1	オシバネ	SPRING	
<056> <幅広用 / FOR WIDE ELASTIC>					
36-3	S28107101	1	ヌノオサエ	CLOTH PRESSER	
37	062630412	2	ナベコ238-56X4	SCREW, PAN M2.38-56X4	
<056> <幅狭用 / FOR NARROW ELASTIC>					
36-4	S28108101	1	ヌノオサエ	CLOTH PRESSER	
37	062630412	2	ナベコ238-56X4	SCREW, PAN M2.38-56X4	
<B257-0V1>					
40-4	※	1	オサエクミ	PRESSER FOOT ASSY	
40-4-1	S28558001	1	ハシオサエクミ	EDGE PRESSER ASSY	
40-4-2	S08806101	1	オサエシジタイ	PRESSER FOOT BASE	
40-4-3	100064005	1	シメネジ3.57	SCREW, M3.57	
40-4-4	S08807101	1	オサエピン	PIN	
40-4-5	048015346	1	トメワE1.5	RETAINING RING, E 1.5	
40-4-6	146427001	1	アナトメネジ3.18クボミ	SET SCREW, SOCKET (CP) M3.18	
40-4-7	S08808001	1	ストップネジ	STOPPER SCREW	
40-4-8	021660102	1	ナット1シユ3.18	NUT, 1 M3.18	
40-4-9	S08809001	1	シメネジ2.38X3.5	SCREW, M2.38X3.5	
40-4-10	S08810001	1	オサエネジリバネ	TWIST SPRING	
40-4-11	060630412	1	バインド238-56X4	SCREW, BIND M2.38-56X4	
40-4-12	S28560001	1	ガイド	GUIDE	
40-4-13	141544001	1	シメネジ3.18	SCREW, M3.18	
40-4-14	S08812001	1	オシバネ	SPRING	

C2. 押工関係 / Presser foot mechanism / Stoffdrückerfuß /
 Mécanisme de pied presseur / Mecanismo de la prensa tela

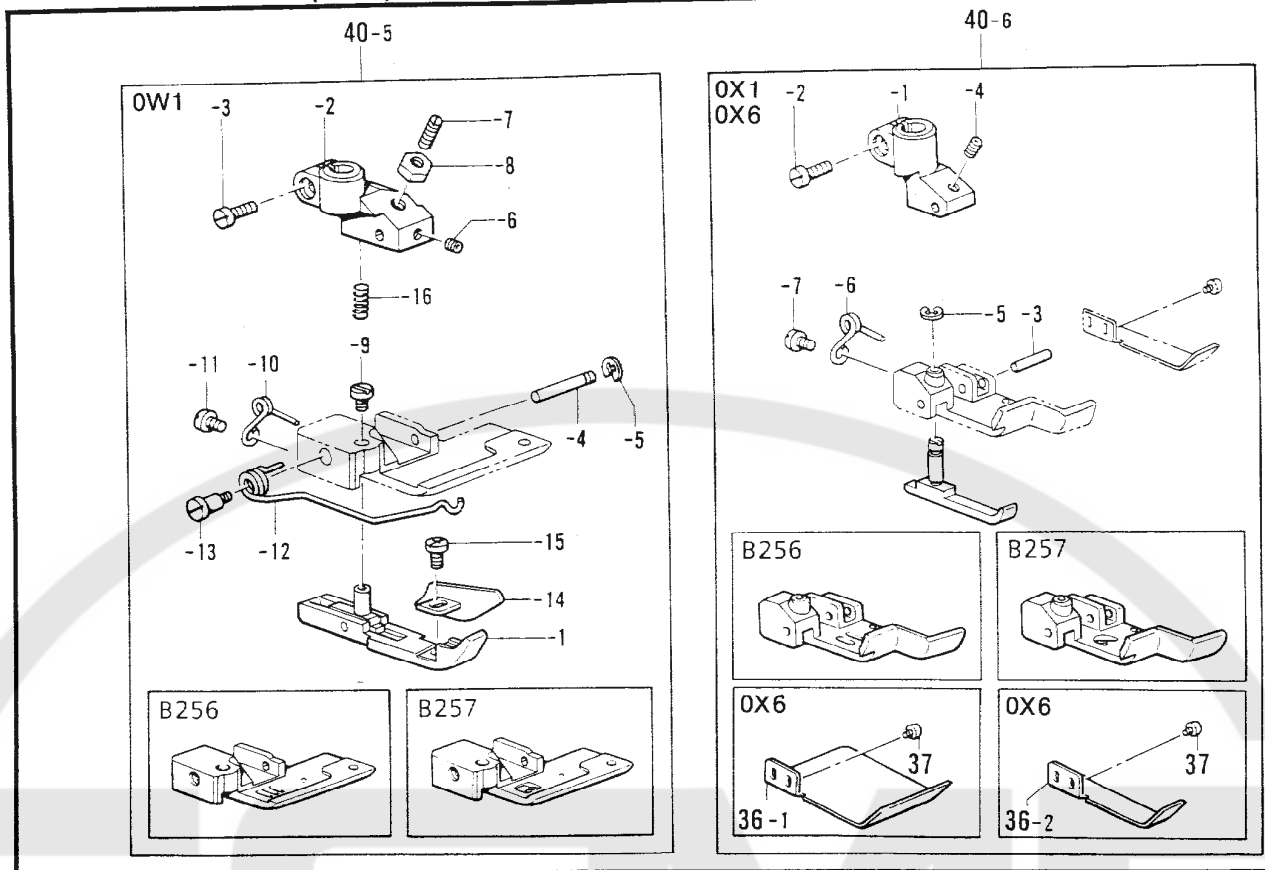

118-256,257-201

D. 針冷却関係 / Needle cooler / Nadelkühlungsvorrichtung /
 Mécanisme du refroidisseur d'aiguille / Mecanismo del enfriador de aguja

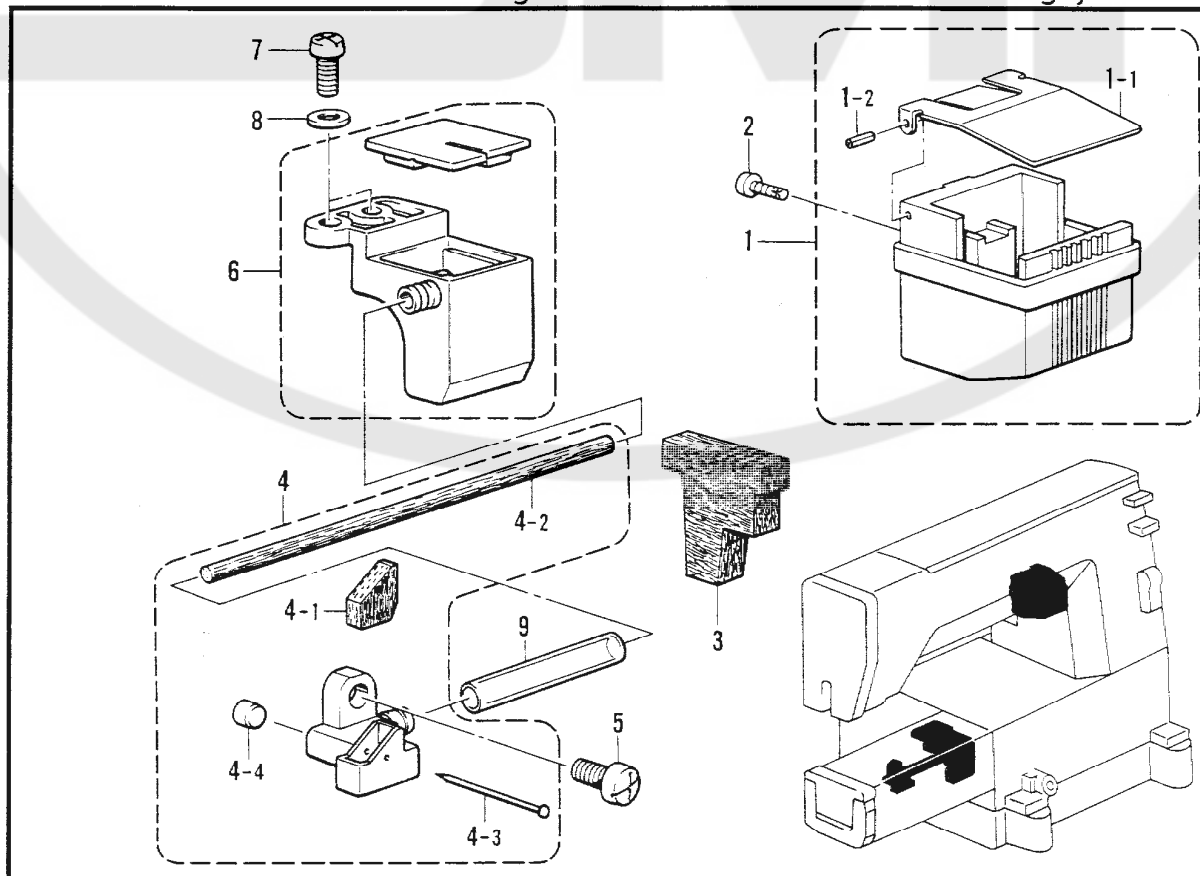

118-256,257-124

C2. 押工関係 / Presser foot mechanism / Stoffdrückerfuß /
Mécanisme de pied presseur / Mecanismo de la prensa tela

REF.NO.	CODE	Q'TY	ヒンメイ	NAME OF PARTS	RM
<0W1>					
40-5	※	1	オサエクミ	PRESSER FOOT ASSY	
40-5-1	S28567001	1	ハシオサエクミ	EDGE PRESSER ASSY	
40-5-2	S08806101	1	オサエシジタイ	PRESSER FOOT BASE	
40-5-3	100064005	1	シメネジ3.57	SCREW, M3.57	
40-5-4	S08807101	1	オサエピン	PIN	
40-5-5	048015346	1	トメワE1.5	RETAINING RING, E 1.5	
40-5-6	146427001	1	アナトメネジ3.18クボミ	SET SCREW, SOCKET (CP) M3.18	
40-5-7	S08808001	1	ストツブネジ	STOPPER SCREW	
40-5-8	021660102	1	ナツト1シユ3.18	NUT, 1 M3.18	
40-5-9	S08809001	1	シメネジ2.38X3.5	SCREW, M2.38X3.5	
40-5-10	S08810001	1	オサエネジリバネ	TWIST SPRING	
40-5-11	060630412	1	バインド238-56X4	SCREW, BIND M2.38-56X4	
40-5-12	S28569001	1	オサエバネ	PRESSER SPRING	
40-5-13	155103001	1	ダンネジ3.18	STUD SCREW, M3.18	
40-5-14	S28570001	1	ガイドF	GUIDE (F)	
40-5-15	062670412	1	ナベコ357-40X4	SCREW, PAN M3.57-40X4	
40-5-16	S08812001	1	オシバネ	SPRING	
<0X1,0X6>					
40-6	※	1	オサエクミ	PRESSER FOOT ASSY	
40-6-1	S28131001	1	オサエシジタイ	PRESSER FOOT BASE	
40-6-2	100064005	1	シメネジ3.57	SCREW, M3.57	
40-6-3	S08783101	1	オサエピン	PIN	
40-6-4	S01374001	1	トメネジ2.38クボミ	SET SCREW, (CP) M2.38	
40-6-5	048020342	1	トメワE2	RETAINING RING, E2	
40-6-6	S08784001	1	オサエバネ	SPRING	
40-6-7	062660512	1	ナベコネジ318-40X5	SCREW, PAN M3.18-40X5	
<0X6> <幅広用 / FOR WIDE ELASTIC>					
36-1	S28105001	1	ヌノオサエ	CLOTH PRESSER	
37	062630412	2	ナベコ238-56X4	SCREW, PAN M2.38-56X4	
<0X6> <幅セマ用 / FOR NARROW ELASTIC>					
36-2	S28106001	1	ヌノオサエ	CLOTH PRESSER	
37	062630412	2	ナベコ238-56X4	SCREW, PAN M2.38-56X4	

118-256,257-201

D. 針冷却関係 / Needle cooler / Nadelkühlungsvorrichtung /
Mécanisme du refroidisseur d'aiguille / Mecanismo del enfriador de aguja

REF.NO.	CODE	Q'TY	ヒンメイ	NAME OF PARTS	RM
1	S08758009	1	ハリイトレイキヤクタンククミ	NEEDLE THREAD COOLER TANK ASSY	
1-1	S08760009	1	ハリイトレイキヤクタンクフタ	NEEDLE THREAD COOLER TANK COVER	
1-2	047200642	2	スプリングピンAW2	PIN, SPRING ROLL AW2	
2	575456001	2	+ナベPタイト3X10	TAPTITE, PAN P M3X10	
3	S08761100	1	ハリイトレイキヤクフェルト	FELT	
4	S28750001	1	フェルトササエクミ	FELT SUPPORT ASSY	
4-1	S28099000	1	フェルトS	FELT (S)	
4-2	S28100000	1	フェルト	FELT	
4-3	S02874001	1	ムシピン	PIN	
4-4	142274001	1	メクラセン	OIL CAP	
5	062680812	1	ナベコ437-40X8	SCREW, PAN M4.37-40X8	
6	S28101000	1	ハリレイキヤクタンククミ	NEEDLE COOLER TANK ASSY	
7	062671012	2	ナベコ357-40X10	SCREW, PAN M3.57-40X10	
8	105161003	2	ザガネ	WASHER	
9	S28104000	1	ビニルチューブ (L=36)	OIL TUBE (L=36)	

118-256,257-124

E1. 送り関係 / Feed mechanism / Transportvorrichtung /
 Mécanisme de l'entraînement / Mecanismo de la alimentación

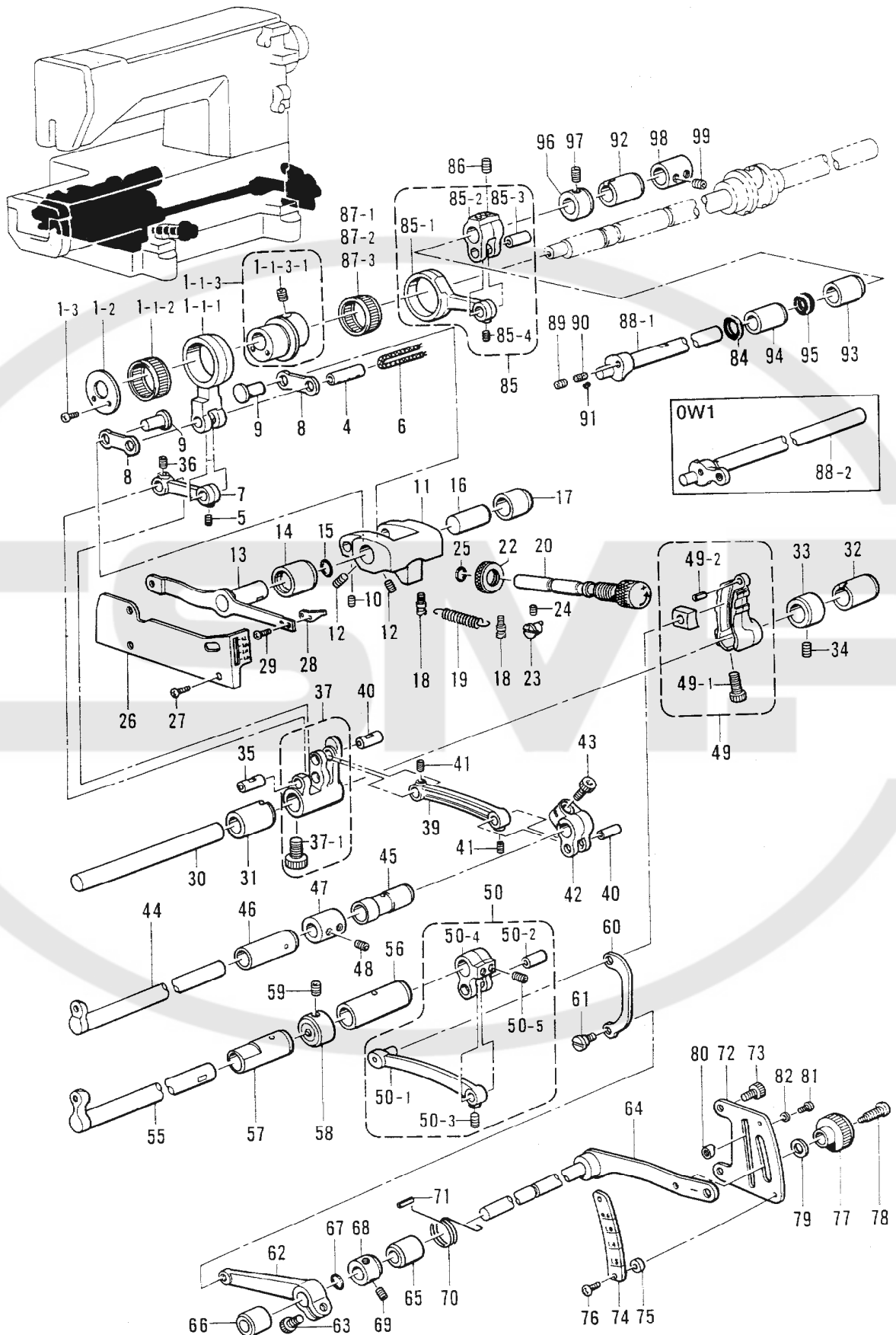

E1. 送り関係 / Feed mechanism / Transportvorrichtung /
Mécanisme de l'entraînement / Mecanismo de la alimentación

REF.NO.	CODE	Q'TY	ヒンメイ	NAME OF PARTS	RM
1	S28159001	1	オクリロッドソウクミ	FEED ROD SET	
1-1	S28160001	1	オクリロッドクミ	FEED ROD ASSY	
1-1-1	S28163001	1	オクリロッド	FEED ROD	
1-1-2	S28164001	1	ニードルジクウケ25	NEEDLE ROLLER BEARING 25	
1-1-3	S28161001	1	オクリヘンシンリンネジツキ	FEED ECCENTRIC WHEEL WITH SCREW	
1-1-3-1	014770622	2	アナトメネジ6.35クボミ	SET SCREW, SOCKET (CP) M6.35	
1-2	S28165001	1	ロッドオサエイタ	FEED ROD PRESSER PLATE	
1-3	062670612	2	ナベコ357-40X6	SCREW, PAN M3.57-40X6	
4	S28166001	1	オクリロッドピン	PIN	
5	014680422	1	アナトメネジ4.37クボミ	SET SCREW, SOCKET (CP) M4.37	
6	140418000	1	クミヒモ (L=56)	WICK (L=56)	
7	S28167001	1	オクリリンクL	FEED LINK (L)	
8	S28168001	1	オクリリンクSクミ	FEED LINK (S) ASSY	
9	S28170001	2	オクリリンクSピン	FEED LINK (S) PIN	
10	014680422	2	アナトメネジ4.37クボミ	SET SCREW, SOCKET (CP) M4.37	
11	S28171001	1	オクリチヨウセツドダイ	FEED ADJUST BRACKET	
12	148857001	4	アナトメネジ6.35クボミ	SET SCREW, SOCKET (CP) M6.35	
13	S28172001	1	オクリチヨウセツレバー	FEED ADJUST LEVER	
14	S28173000	1	チヨウセツドダイメタルL	FEED ADJUST BRACKET BUSH (L)	
15	081012070	1	OリングP12	O RING, P12	
16	S28174001	1	チヨウセツドダイジク	FEED ADJUST BRACKET SHAFT	
17	S28175000	1	チヨウセツドダイメタルR	FEED ADJUST BRACKET BUSH (R)	
18	S28176001	2	バネカケ	SPRING HOOK	
19	S28249001	1	モドシバネ	SPRING	
20	S28177001	1	オクリチヨウセツネジ	FEED ADJUST SCREW	
22	S28179001	1	チヨウセツネジツマミナツト	FEED ADJUST SCREW KNOB NUT	
23	S28180001	1	チヨウセツネジストツパ	FEED ADJUST SCREW STOPPER	
24	014680622	1	アナトメネジ4.37クボミ	SET SCREW, SOCKET (CP) M4.37	
25	081007070	1	OリングP7	O RING, P7	
26	S28181001	1	オクリチヨウセツカバー	FEED ADJUST COVER	
27	106629002	3	シメネジ4.37	SCREW, M4.37	
28	S28182001	1	オクリピッチシジイタ	FEED PITCH CONTROL PLATE	
29	100105005	2	シメネジ2.38	SCREW, M2.38	
30	S28183001	1	オクリジク	FEED SHAFT	
31	S28184000	1	オクリジクメタルL	FEED SHAFT BUSH (L)	
32	S28185000	1	オクリジクメタルR	FEED SHAFT BUSH (R)	
33	117671002	1	セツトカラー	SET COLLAR	
34	014770622	2	アナトメネジ6.35クボミ	SET SCREW, SOCKET (CP) M6.35	
35	S28186001	1	ロッドピン	ROD PIN	
36	014680422	1	アナトメネジ4.37クボミ	SET SCREW, SOCKET (CP) M4.37	
37	S28844001	1	シュオクリウデクミ	MAIN FEED ARM ASSY	
37-1	018081622	1	アナボルト8X16	BOLT, SOCKET M8X16	
39	S28188001	1	シュオクリリンク	MAIN FEED LINK	
40	S28186001	2	ロッドピン	ROD PIN	
41	014680422	2	アナトメネジ4.37クボミ	SET SCREW, SOCKET (CP) M4.37	
42	S28189001	1	シュオクリジクウデ	MAIN FEED SHAFT ARM	
43	018771432	1	アナボルト635-40X14	BOLT, SOCKET M6.35-40X14	
44	S28190001	1	シュオクリジク	MAIN FEED SHAFT	
45	S28191001	1	シュオクリジクメタルR	MAIN FEED SHAFT BUSH (R)	
46	S28192001	1	シュオクリジクメタルL	MAIN FEED SHAFT BUSH (L)	
47	S28193001	1	セツトカラー	SET COLLAR	
48	148857001	2	アナトメネジ6.35クボミ	SET SCREW, SOCKET (CP) M6.35	
49	S28194001	1	サドウオクリウデコマクミ	DIFFERENTIAL FEED ARM BLOCK ASSY	
49-1	018771432	1	アナボルト635-40X14	BOLT, SOCKET M6.35-40X14	
49-2	047400842	1	スプリングピンAW4X8	PIN, SPRING ROLL AW4x8	
50	S28790001	1	サドウオクリジクウデクミ	DIFFERENTIAL FEED SHAFT ARM ASSY	
50-1	S28198001	1	サドウオクリリンク	DIFFERENTIAL FEED LINK	
50-2	S28186001	1	ロッドピン	ROD PIN	
50-3	014680422	1	アナトメネジ4.37クボミ	SET SCREW, SOCKET (CP) M4.37	

E1. 送り関係 / Feed mechanism / Transportvorrichtung /
 Mécanisme de l'entraînement / Mecanismo de la alimentación

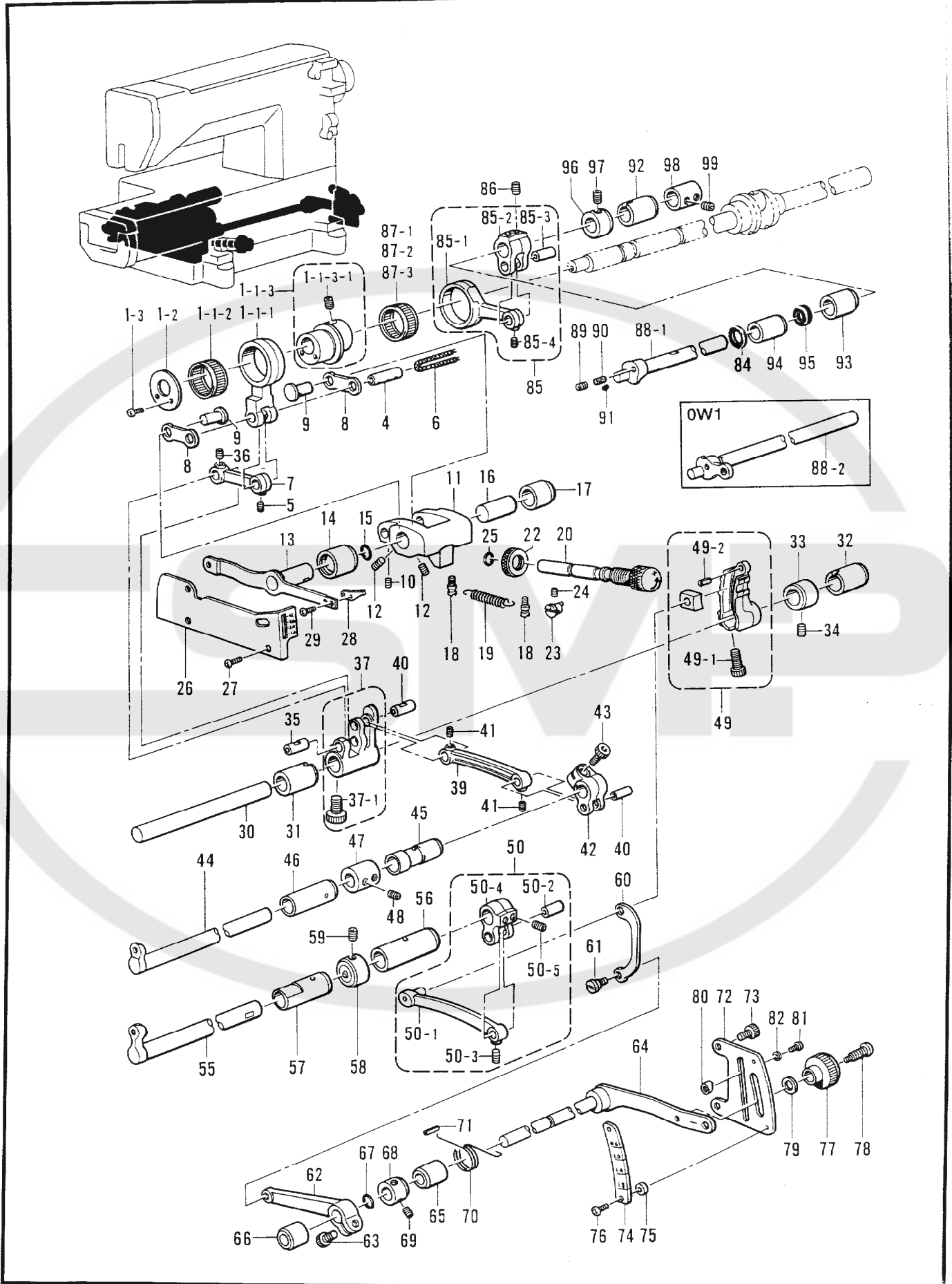

E1. 送り関係 / Feed mechanism / Transportvorrichtung /
Mécanisme de l'entraînement / Mecanismo de la alimentación

REF.NO.	CODE	Q'TY	ヒンメイ	NAME OF PARTS	RM
50-4	S28199001	1	サドウオクリジクウデ	DIFFERENTIAL FEED SHAFT ARM	
50-5	014770622	2	アナトメネジ6.35クボミ	SET SCREW, SOCKET (CP) M6.35	
55	S28200001	1	サドウオクリジク	DIFFERENTIAL FEED SHAFT	
56	S28201001	1	サドウオクリジクメタルR	DIFFERENTIAL FEED SHAFT BUSH (R)	
57	S28202001	1	サドウオクリジクメタルL	DIFFERENTIAL FEED SHAFT BUSH (L)	
58	117671002	1	セツトカラー	SET COLLAR	
59	014770622	2	アナトメネジ6.35クボミ	SET SCREW, SOCKET (CP) M6.35	
60	S28203001	1	サドウリンク	DIFFERENTIAL FEED ADJUST LINK	
61	155167001	1	ダンネジ5.56	STUD SCREW, M5.56	
62	S28204001	1	サドウリンクレバー	DIFFERENTIAL FEED ADJUST LINK LEVER	
63	018771432	1	アナボルト635-40X14	BOLT, SOCKET M6.35-40X14	
64	S28205001	1	サドウチヨウセツレバー	DIFFERENTIAL FEED ADJUST LEVER	
65	S28206000	1	サドウレバーメタルR	DIFFERENTIAL FEED LEVER BUSH (R)	
66	S28207000	1	サドウレバーメタルL	DIFFERENTIAL FEED LEVER BUSH (L)	
67	108549001	1	Oリング	O RING	
68	159491001	1	セツトカラー	SET COLLAR	
69	014760622	2	アナトメネジ5.95	SET SCREW, SOCKET (CP) M5.95	
70	S28208001	1	レバーバネ	LEVER SPRING	
71	047501242	1	スプリングピンAW5	PIN, SPRING ROLL AW5	
72	S28209001	1	サドウチヨウセツレバーイタ	DIFFERENTIAL FEED LEVER PLATE	
73	018061022	2	アナボルト6X10	BOLT, SOCKET M6X10	
74	S28210001	1	サドゥリヨウウメモリイタ	DIFFERENTIAL STITCH CONTROL	
75	S28248001	2	カラー	COLLAR	
76	062670812	2	ナベコ3.57-40X8	SCREW, PAN M3.57-40X8	
77	S20549101	1	セツトネジツマミ	SET SCREW KNOB	
78	S20550002	1	セツトネジ	SET SCREW	
79	S20560001	1	サラバネザガネ	SPRING WASHER	
80	S25818002	2	チヨウセツレバーストツバ	STOPPER FOR FEED ADJUST LEVER	
81	062350616	2	ナベコM3.5X6	SCREW, PAN M3.5X6	
82	105161004	2	ザガネ	WASHER	
84	148559100	1	ゴム	RUBBER	
85	S28211001	1	ジヨウゲオクリロッドクミ	FEED LIFTING ROD ASSY	
85-1	S28212001	1	ジヨウゲオクリロッド	FEED LIFTING ROD	
85-2	S28213001	1	ジヨウゲオクリウデ	FEED LIFTING ARM	
85-3	S28186001	1	ロッドピン	ROD PIN	
85-4	014680422	1	アナトメネジ4.37クボミ	SET SCREW, SOCKET (CP) M4.37	
86	014770622	2	アナトメネジ6.35クボミ	SET SCREW, SOCKET (CP) M6.35	
87-1	S20500001	1	ニードルジクウケ24	NEEDLE ROLLER BEARING 24	
87-2	S20500002	1	ニードルジクウケ24	NEEDLE ROLLER BEARING 24	
87-3	S20500003	1	ニードルジクウケ24	NEEDLE ROLLER BEARING 24	
88-1	S28214001	1	ジヨウゲオクリジク	FEED LIFTING SHAFT	
89	153675001	1	アナトメネジ4.37	SET SCREW, SOCKET M4.37	
90	S28845000	1	フェルト	FELT	
91	S12718000	1	ケミカルフェルト	CHEMICAL FELT	
92	S28216000	1	ジヨウゲジクメタルR	FEED LIFTING SHAFT BUSH (R)	
93	S28217000	1	ジヨウゲジクメタルM	FEED LIFTING SHAFT BUSH (M)	
94	S28218001	1	ジヨウゲジクメタルL	FEED LIFTING SHAFT BUSH (L)	
95	S12827000	1	ダストシール	DUST SEAL	
96	159491001	1	セツトカラー	SET COLLAR	
97	014760622	2	アナトメネジ5.95	SET SCREW, SOCKET (CP) M5.95	
98	S28193001	1	セツトカラー	SET COLLAR	
99	148857001	2	アナトメネジ6.35クボミ	SET SCREW, SOCKET (CP) M6.35	
88-2	S28215001	1	<OW1> ジヨウゲオクリジク	FEED LIFTING SHAFT	

E2. 送り関係 / Feed mechanism / Transportvorrichtung /
 Mécanisme de l'entraînement / Mecanismo de la alimentación

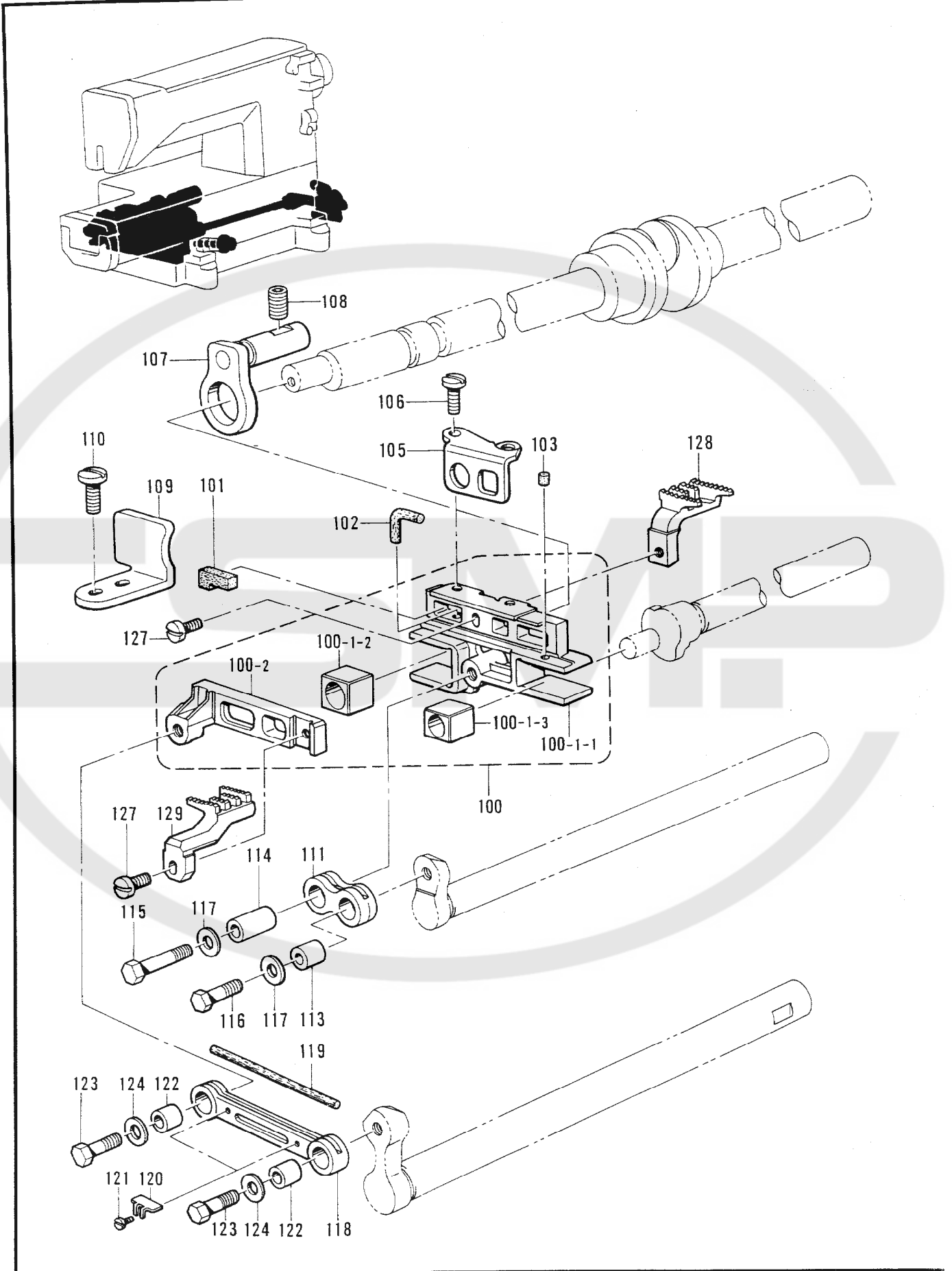

E2. 送り関係 / Feed mechanism / Transportvorrichtung /
Mécanisme de l'entraînement / Mecanismo de la alimentación

REF.NO.	CODE	Q'TY	ヒンメイ	NAME OF PARTS	RM
100	S28793001	1	オクリダイクミ	FEED BAR ASSY	
100-1	S28219001	1	オクリダイカクゴマクミ	FEED BAR SLIDE BLOCK ASSY	
100-1-1	S28220001	1	シユオクリダイ	MAIN FEED BAR	
100-1-2	S28221000	1	オクリダイカクゴマB	FEED BAR SLIDE BLOCK (B)	
100-1-3	S28222000	1	オクリダイカクゴマF	FEED BAR SLIDE BLOCK (F)	
100-2	S28225001	1	サドウオクリダイ	DIFFERENTIAL FEED BAR	
101	S28223000	1	シユオクリダイフェルト	MAIN FEED BAR FELT	
102	S05246000	1	フェルト	FELT	
103	S28224000	1	フェルトS	FELT (S)	
105	S28226001	1	サドウオクリダイアンナイ	DIFFERENTIAL FEED BAR GUIDE	
106	112751003	2	シメネジ3.57	SCREW, M3.57	
107	S28227001	1	オクリダイアンナイR	FEED BAR GUIDE (R)	
108	014780622	1	アナトメネジ6.35クボミ	SET SCREW, SOCKET (CP) M6.35	
109	S28228001	1	オクリダイアンナイL	FEED BAR GUIDE (L)	
110	100644005	2	シメネジ4.37	SCREW, M4.37	
111	S28229000	1	シユオクリジクリンク	MAIN FEED SHAFT LINK	
113	S28232001	1	リンクカラーS	LINK COLLAR (S)	
114	S28233001	1	リンクカラーL	LINK COLLAR (L)	
115	148186001	1	ボルト4.76	BOLT, M4.76	
116	S28843001	1	ボルト4.76	BOLT, M4.76	
117	155157001	2	ザガネ	WASHER	
118	S28234000	1	サドウオクリジクリンク	DIFFERENTIAL FEED SHAFT LINK	
119	S28235000	1	リンクフェルトL	LINK FELT (L)	
120	S28231000	2	フェルトオサエ	FELT SUPPORT	
121	060630412	2	バインド238-56X4	SCREW, BIND M2.38-56X4	
122	S28232001	2	リンクカラーS	LINK COLLAR (S)	
123	S28843001	2	ボルト4.76	BOLT, M4.76	
124	155157001	2	ザガネ	WASHER	
127	S28236001	2	シメネジ3.57	SCREW, M3.57	
128	※	1	シユオクリバ	MAIN FEED DOG	
129	※	1	サドウオクリバ	DIFFERENTIAL FEED DOG	

F. 下軸関係 / Lower shaft mechanism / Untere Welle /
 Mécanisme de l'arbre inférieur / Mecanismo del eje inferior

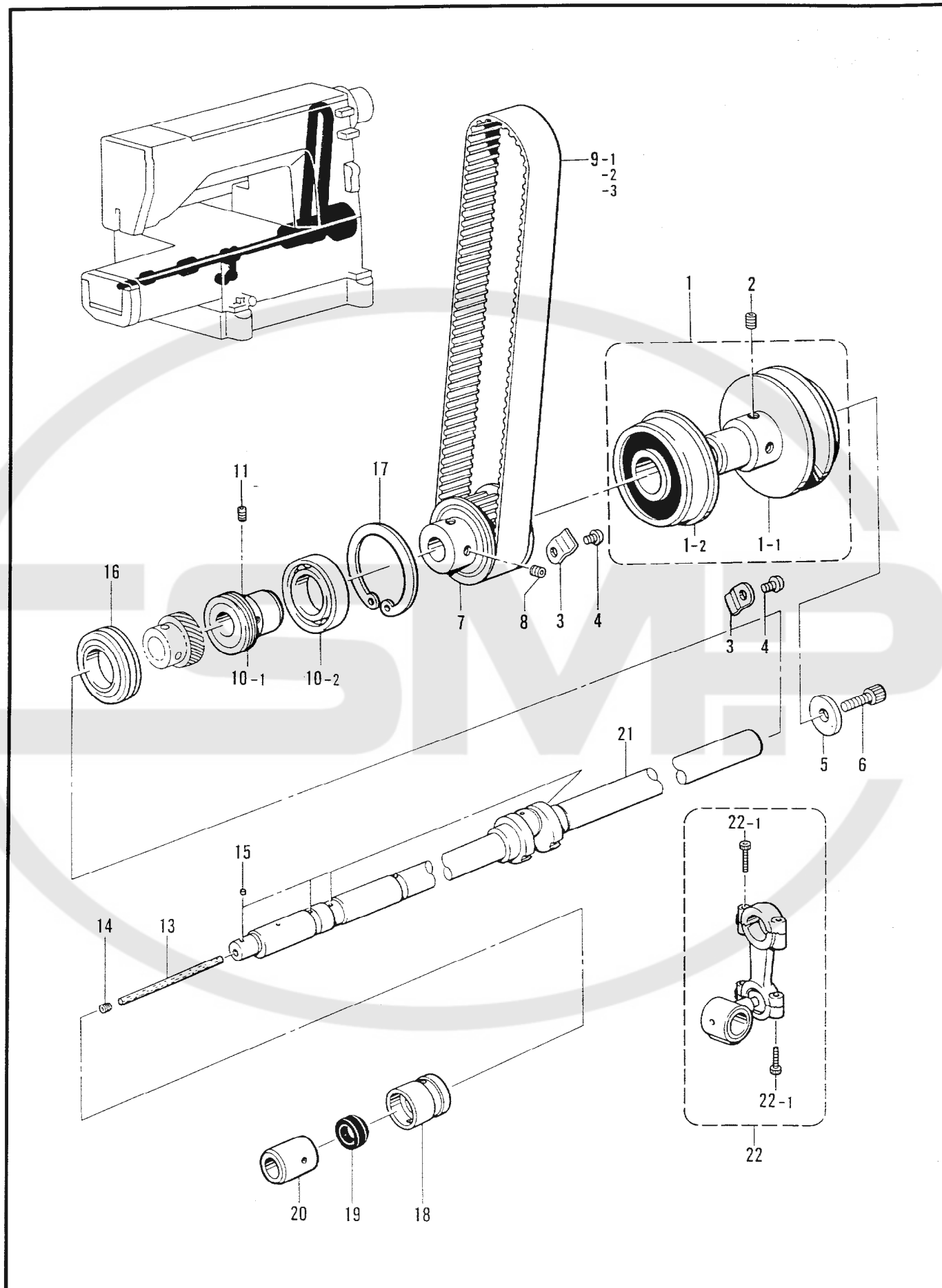

F. 下軸関係 / Lower shaft mechanism / Untere Welle /
Mécanisme de l'arbre inférieur / Mecanismo del eje inferior

REF.NO.	CODE	Q'TY	ヒンメイ	NAME OF PARTS	RM
1	S08889101	1	Vベルトプーリクミ	V-BELT PULLEY ASSY	
1-1	S08890001	1	Vベルトプーリ	V-BELT PULLEY	
1-2	S14622001	1	タマジクウケ6304VV	BALL BEARING, 6304VV	
2	014780622	2	アナトメネジ6.35クボミ	SET SCREW, SOCKET (CP) M6.35	
3	153734001	2	アームササエイタバネ	PLATE SPRING	
4	062680612	2	ナベコ4.37-40X6	SCREW, PAN M4.37-40X6	
5	154886001	1	ザガネ	WASHER	
6	018771432	1	アナボルト635-40X14	BOLT, SOCKET M6.35-40X14	
7	S08892001	1	タイミングプーリDクミ	TIMING PULLEY (D) ASSY	
8	014770622	2	アナトメネジ6.35クボミ	SET SCREW, SOCKET (CP) M6.35	
9-1	★ S12806001	1	タイミングベルト	TIMING BELT	
9-2	★ S12806002	1	タイミングベルト	TIMING BELT	
9-3	★ S12806003	1	タイミングベルト	TIMING BELT	
10	S28363001	1	タマジクウケクミ	BALL BEARING ASSY	
10-1	S28364001	1	ウオーム	WORM	
10-2	S28365001	1	タマジクウケ6005DU	BALL BEARING, 6005DU	
11	014770622	2	アナトメネジ6.35クボミ	SET SCREW, SOCKET (CP) M6.35	
13	S28372000	1	フェルト	FELT	
14	153675001	1	アナトメネジ4.37	SET SCREW, SOCKET M4.37	
15	S12718000	4	ケミカルフェルト	CHEMICAL FELT	
16	S28373001	1	タマジクウケ6203	BALL BEARING, 6203	
17	048470242	1	トメワアナヨウC47	RETAINING RING, C47	
18	S28374000	1	シタジクメタルR	LOWER SHAFT BUSH (R)	
19	S28375000	1	ダストシール	DUST SEAL	
20	S28376000	1	シタジクメタルL	LOWER SHAFT BUSH (L)	
			<アカ>	<RED>	
21	S28367011	1	シタジク	LOWER SHAFT	
22	S28368011	1	ルーパロツドクミ	LOOPER ROD ASSY	
22-1	018401422	4	アナボルト4X14	BOLT, SOCKET M4X14	
			<アオ>	<BLUE>	
21	S28367012	1	シタジク	LOWER SHAFT	
22	S28368012	1	ルーパロツドクミ	LOOPER ROD ASSY	
22-1	018401422	4	アナボルト4X14	BOLT, SOCKET M4X14	

★印はアームベッド上面のテーキンに合わせてご選択下さい。(取扱説明書タイミングベルト交換の仕方をご参照ください。)

Select parts marked with a star (★) according to the index on the arm bed top. (Refer to timing belt replacement in the instruction manual.)

Die mit dem Zeichen (★) markierten Teile entsprechend dem an der Oberseite des Armbetts angegebenen Index auswählen. (Siehe Ersetzen des Synchronriemens in der Bedienungsanleitung.)

Sélectionner les pièces indiquées par une étoile (★) selon l'index situé sur le plateau du bras. (Se reporter à la section du manuel d'instructions concernant le remplacement de la courroie de synchronisation.)

Las piezas marcadas con un asterisco (★) se deben seleccionar de acuerdo al índice de la parte superior de la mesa del brazo. (Consultar la sección sobre el cambio de la correa de distribución en el manual de instrucciones.)

G. ルーパー関係 / Looper mechanism / Greifer /
Mécanisme des griffes / Mecanismo del presilladora

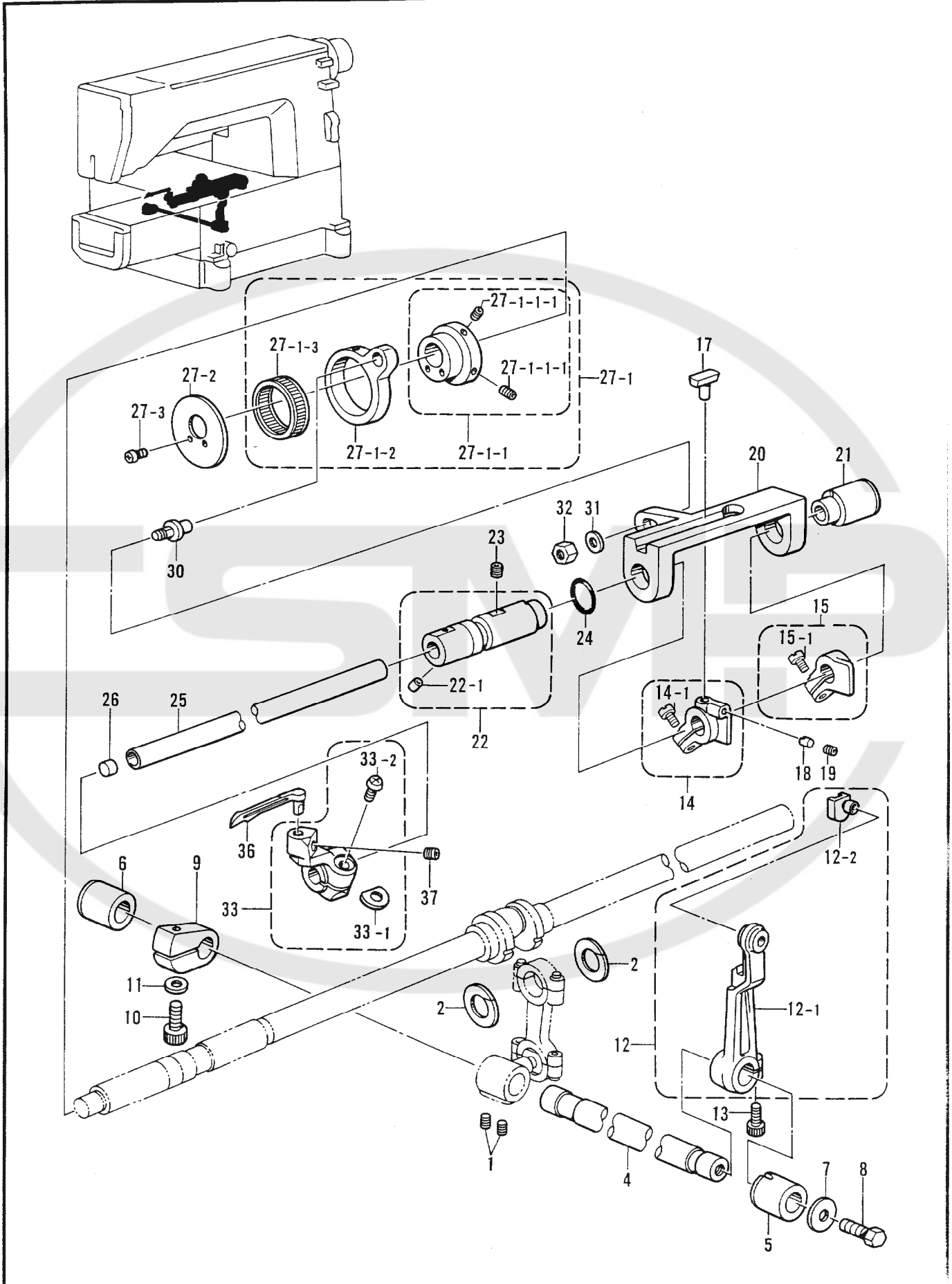

G. ルーパー関係 / Looper mechanism / Greifer /
 Mécanisme des griffes / Mecanismo del presilladora

REF.NO.	CODE	Q'TY	ヒンメイ	NAME OF PARTS	RM
1	014770622	2	アナトメネジ6.35クボミ	SET SCREW, SOCKET (CP) M6.35	
2	S20598000	2	ロッドフレドメ	ROD STOPPER	
4	S28377001	1	ルーバジク	LOOPER SHAFT	
5	S28184000	1	オクリジクメタルL	FEED SHAFT BUSH (L)	
6	S28842001	1	ルーバジクメタルB	LOOPER SHAFT BUSH (B)	
7	151090001	1	スラストザガネ	THRUST WASHER	
8	017771412	1	ボルト6.35X14	BOLT, M6.35X14	
9	S28848000	1	バランス	BALANCE	
10	018062022	1	アナボルト6X20	BOLT, SOCKET M6X20	
11	155559001	1	ヒラザガネ	WASHER, PLAIN	
12	S28823001	1	ルーバヨウドウウデクミ	LOOPER DRIVING ARM ASSY	
12-1	S28824001	1	ルーバヨウドウウデ	LOOPER DRIVING ARM	
12-2	S28825001	1	ヨウドウウデカクゴマ	DRIVING ARM SLIDE BLOCK	
13	018771432	1	アナボルト635-40X14	BOLT, SOCKET M6.35-40X14	
14	S28826001	1	スライダホルダクミ	SLIDER HOLDER ASSY	
14-1	100064005	1	シメネジ3.57	SCREW, M3.57	
15	S28828001	1	カクゴマホルダクミ	SLIDE BLOCK HOLDER ASSY	
15-1	100064005	1	シメネジ3.57	SCREW, M3.57	
17	S28383001	1	スライダー	SLIDER	
18	S28384001	1	スライダーオシ	SLIDER PUSH	
19	014680422	1	アナトメネジ4.37クボミ	SET SCREW, SOCKET (CP) M4.37	
20	S28385000	1	ルーバボウガイド	LOOPER BAR GUIDE	
21	S28386001	1	ルーバボウメタルR	LOOPER BAR BUSH (R)	
22	S28387001	1	ルーバボウメタルLクミ	LOOPER BAR BUSH (L) ASSY	
22-1	047402042	1	スプリングピンA4	PIN, SPRING ROLL A4	
23	014780622	1	アナトメネジ6.35クボミ	SET SCREW, SOCKET (CP) M6.35	
24	081012070	1	OリングP12	O RING, P12	
25	S28389001	1	ルーバボウ	LOOPER BAR	
26	S28869000	1	メクラセン	OIL CAP	
27	S28795001	1	ゼンゴロツドソウクミ	LONGITUDINAL FEED ROD SET	
27-1	S28390001	1	ルーバゼンゴロツドクミ	LOOPER LONGITUDINAL FEED ROD ASSY	
27-1-1	S28391001	1	ルーバヘンシンリンネジツキ	LOOPER ECCENTRIC WHEEL WITH SCREW	
27-1-1-1	014680622	2	アナトメネジ4.37クボミ	SET SCREW, SOCKET (CP) M4.37	
27-1-2	S28393001	1	ルーバゼンゴロツド	LOOPER LONGITUDINAL FEED ROD	
27-1-3	S12915001	1	ニードルジクウケ25	NEEDLE ROLLER BEARING 25	
27-2	S28165001	1	ロツドオサエイタ	FEED ROD PRESSER PLATE	
27-3	062670612	2	ナベコ357-40X6	SCREW, PAN M3.57-40X6	
30	S28394001	1	ゼンゴロツドピン	PIN	
31	148847001	1	ザガネ	WASHER	
32	110161006	1	ナツト4.76	NUT, M4.76	
33	S28885001	1	ルーバホルダクミ	LOOPER HOLDER ASSY	
33-1	S28381000	1	スベサ	SPACER	
33-2	062671012	1	ナベコ357-40X10	SCREW, PAN M3.57-40X10	
36	S28396001	1	ルーバ	LOOPER	
37	014680422	1	アナトメネジ4.37クボミ	SET SCREW, SOCKET (CP) M4.37	

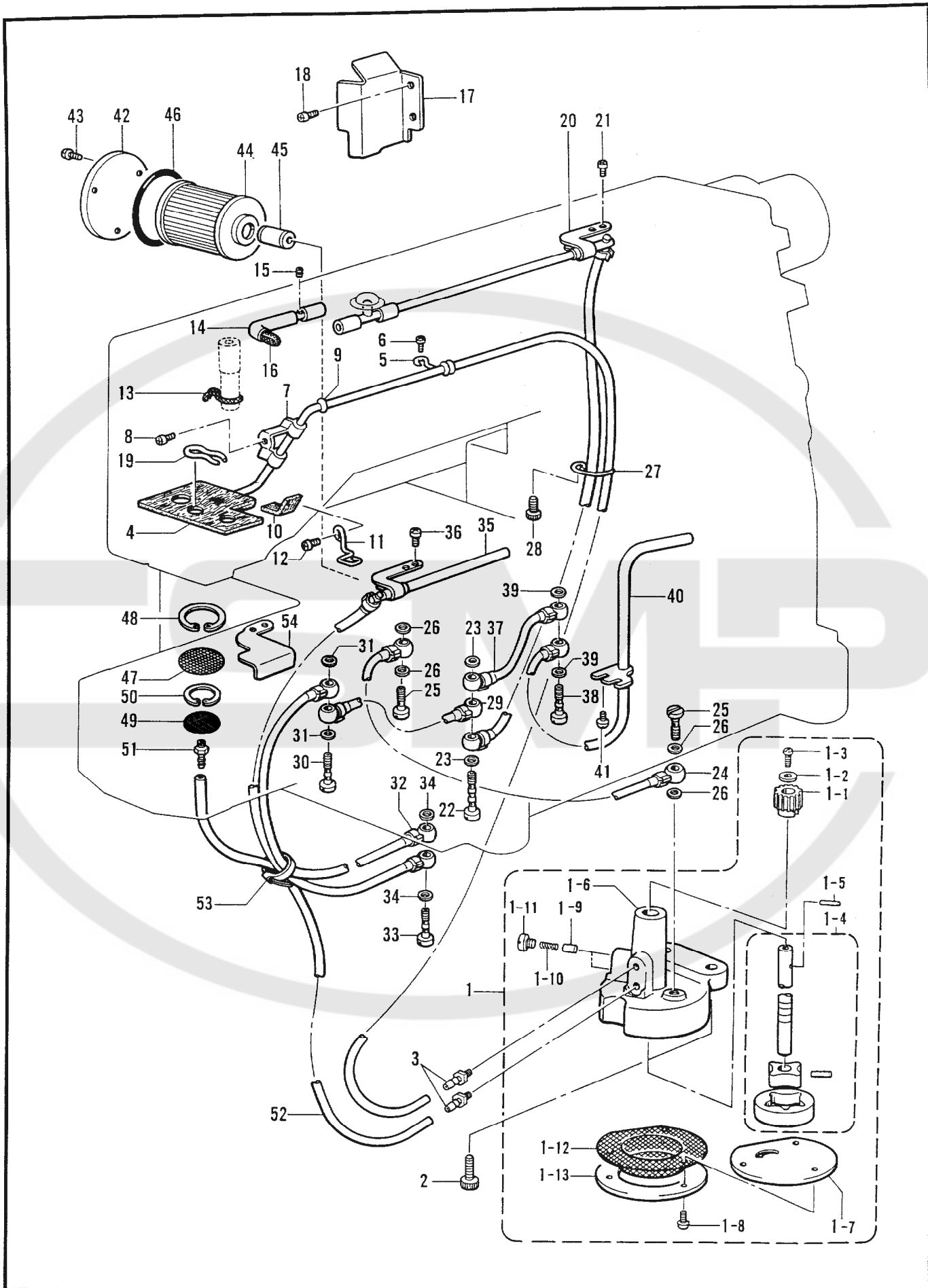

H. 給油潤滑関係 / Lubrication / Schmierung / Lubrification / Lubricación

REF.NO.	CODE	Q'TY	ヒンメイ	NAME OF PARTS	RM
1	S28397101	1	トロコイドポンプクミ	PUMP ASSY	
1-1	144619000	1	ウオームホイール	WORM WHEEL	
1-2	025350332	1	ヒラザガネダイ3.5	WASHER, PLAIN L 3.5	
1-3	062670812	1	ナベコ3.57-40X8	SCREW, PAN M3.57-40X8	
1-4	S28398001	1	ポンプロータークミ	PUMP INNER ROTER ASSY	
1-5	144622001	1	ミゾツキピンEガタ	DOWEL PIN (E)	
1-6	S28400100	1	ポンプケース	PUMP CASE	
1-7	147527000	1	ポンプフタ	PUMP COVER	
1-8	062671012	3	ナベコ357-40X10	SCREW, PAN M3.57-40X10	
1-9	144875001	2	プランジャー	PLUNGER	
1-10	144876001	2	プランジャーバネ	PLUNGER SPRING	
1-11	112467002	2	シメネジ6.35	SCREW, M6.35	
1-12	147528100	1	ロカモウ	OIL FILTER	
1-13	147529000	1	ロカモウオサエ	OIL FILTER FLANGE	
2	018061622	2	アナボルト6X16	BOLT, SOCKET M6X16	
3	142359001	2	オイルクチ	OIL FEEDING PIPE	
4	S28401001	1	チューブクミ	OIL TUBE ASSY	
5	112743001	1	クミヒモササエ	WICK SUPPORT	
6	062670612	1	ナベコ357-40X6	SCREW, PAN M3.57-40X6	
7	151429001	1	チューブホルダ	TUBE HOLDER	
8	062670612	1	ナベコ357-40X6	SCREW, PAN M3.57-40X6	
9	118770001	1	パツキン	PACKING	
10	S08943000	1	カクゴマフェルト	FELT	
11	S08944001	1	フェルトオサエ	FELT SUPPORT	
12	062670612	1	ナベコ357-40X6	SCREW, PAN M3.57-40X6	
13	157840000	1	クミヒモ3X3 (L = 100)	WICK 3X3 (L = 100)	
14	S08945001	1	オイルパイプ	OIL PIPE	
15	014680622	1	アナトメネジ4.37クボミ	SET SCREW, SOCKET (CP) M4.37	
16	S08946000	1	フェルト	FELT	
17	S08947001	1	オイルヨケイタ	OIL STOPPER PLATE	
18	062670612	2	ナベコ357-40X6	SCREW, PAN M3.57-40X6	
19	145737001	1	フェルトオサエ	FELT SUPPORT	
20	S08948001	1	ロツドオイルパイプUクミ	MAIN OIL PIPE (U) ASSY	
21	062670612	2	ナベコ357-40X6	SCREW, PAN M3.57-40X6	
22	112351001	1	ハイユパイプネジ	OIL FEEDING PIPE SCREW	
23	159476000	2	ザガネ	WASHER	
24	S12846001	1	ビニルチューブクミ	OIL TUBE ASSY	
25	112359001	2	ハイユパイプツギテネジ	OIL FEEDING PIPE JOINT SCREW	
26	159476000	4	ザガネ	WASHER	
27	S28405001	1	チューブガイド	TUBE GUIDE	
28	018060822	1	アナボルト6X8	BOLT, SOCKET M6X8	
29	S28846001	1	ビニルチューブクミ	OIL TUBE ASSY	
30	112364001	1	ハイユパイプツギテネジ	OIL FEEDING PIPE JOINT SCREW	
31	159476000	2	ザガネ	WASHER	
32	S28403001	1	ビニルチューブクミ	OIL TUBE ASSY	
33	112364001	1	ハイユパイプツギテネジ	OIL FEEDING PIPE JOINT SCREW	
34	159476000	2	ザガネ	WASHER	
35	S28406001	1	ロツドオイルパイプDクミ	MAIN OIL PIPE (D) ASSY	
36	062670612	2	ナベコ357-40X6	SCREW, PAN M3.57-40X6	
37	S28409001	1	ビニルチューブクミ	OIL TUBE ASSY	
38	112364001	1	ハイユパイプツギテネジ	OIL FEEDING PIPE JOINT SCREW	
39	159476000	2	ザガネ	WASHER	
40	S28411001	1	ギアキユウユパイプクミ	GEAR OIL PIPE ASSY	
41	062680812	2	ナベコ437-40X8	SCREW, PAN M4.37-40X8	
42	S12987001	1	オイルフィルターフタ	OIL FILTER CAP	
43	062680812	3	ナベコ437-40X8	SCREW, PAN M4.37-40X8	
44	S08956000	1	オイルフィルター	OIL FILTER	
45	S08957001	1	オイルクチ	OIL FEEDING PIPE	
46	081044070	1	OリングP44	O RING, P44	
47	S28851000	1	ロカモウU	OIL FILTER (U)	
48	048240242	1	トメワアナヨウC24	RETAINING RING, C24	
49	S28852000	1	ロカモウD	OIL FILTER (D)	
50	048180242	1	トメワアナヨウC18	RETAINING RING, C18	
51	142359001	1	オイルクチ	OIL FEEDING PIPE	
52	S28415000	1	ビニルチューブ (L = 225)	OIL TUBE (L = 225)	
53	340400001	1	ユニタイバンド	BEAD BAND	
54	S28416001	1	アブラヨケイタ	OIL STOPPER PLATE	

J. スプレダー関係 / Spreader mechanism / Spreizvorrichtung /
 Mécanisme de l'étendeur / Mecanismo extendedor

B257

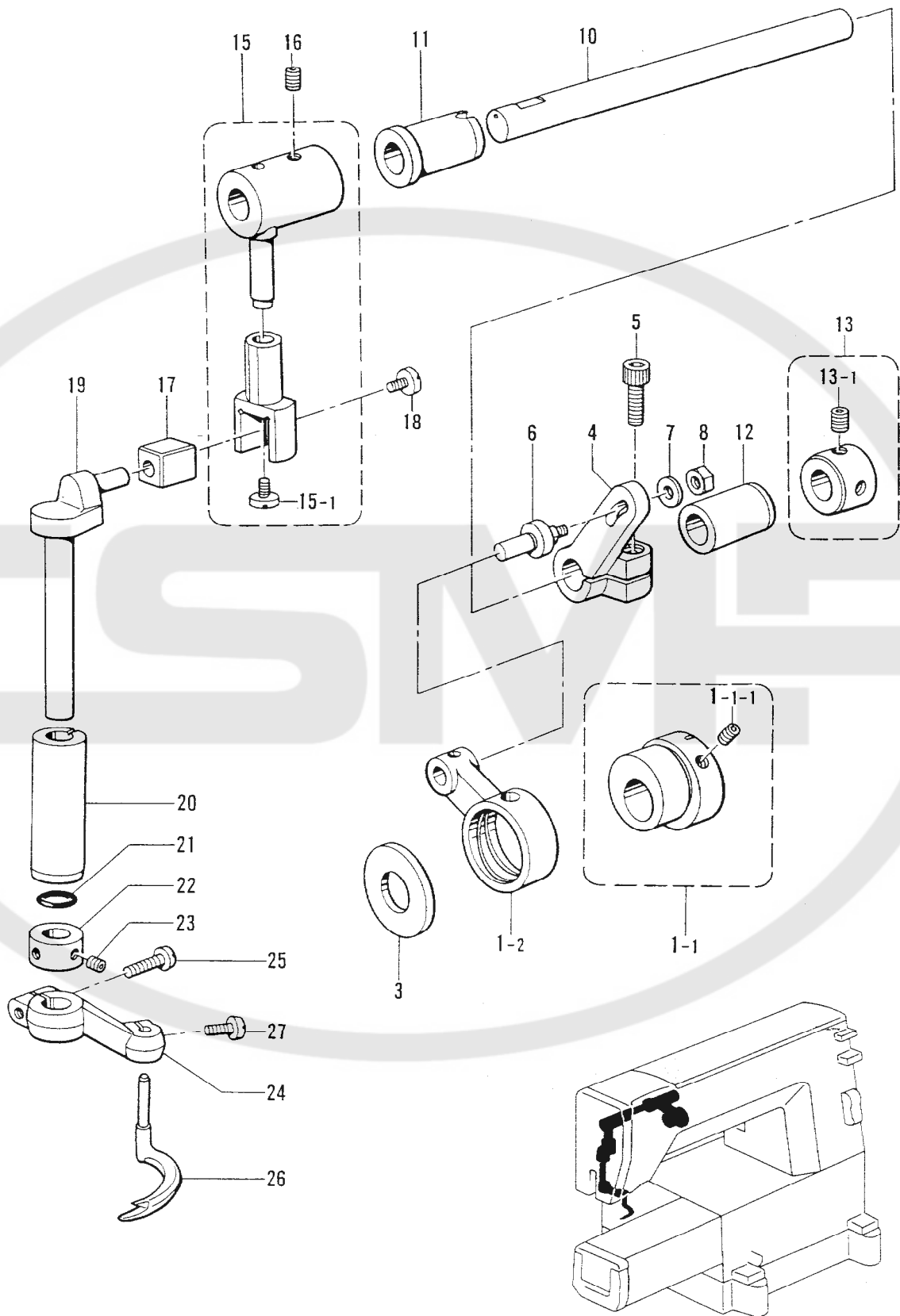

J. スプレダー関係 / Spreader mechanism / Spreizvorrichtung /
 Mécanisme de l'étendeur / Mecanismo extendedor

REF.NO.	CODE	Q'TY	ヒンメイ	NAME OF PARTS	RM
			<B257>		
1	S08923101	1	スプレダヘンシンリンクミ	SPREADER ECCENTRIC WHEEL ASSY	
1-1	S10656001	1	ヘンシンリンネジツキ	ECCENTRIC WHEEL WITH SCREW	
1-1-1	014680622	2	アナトメネジ4.37クボミ	SET SCREW, SOCKET (CP) M4.37	
1-2	S08925000	1	スプレダロツド	SPREADER ROD	
3	101482001	1	レンカンシキリイタ	CONNECTING ROD PARTITION PLATE	
4	S08926101	1	スプレダレバー	SPREADER LEVER (R)	
5	018771432	1	アナボルト635-40X14	BOLT, SOCKET M6.35-40X14	
6	S13809001	1	スプレダロツドピン	PIN	
7	148847001	1	ザガネ	WASHER	
8	110161006	1	ナツト4.76	NUT, M4.76	
10	S08927001	1	スプレダジク	SPREADER SHAFT	
11	148196000	1	ウワメスサドウウデメタルL	SPREADER SHAFT BUSH (L)	
12	148197000	1	ウワメスサドウウデメタルR	SPREADER SHAFT BUSH (R)	
13	S03421001	1	セットカラークミ	SET COLLAR ASSY	
13-1	014770622	2	アナトメネジ6.35クボミ	SET SCREW, SOCKET (CP) M6.35	
15	S08928001	1	スプレダレバーLクミ	SPREADER LEVER (L) ASSY	
15-1	148834001	1	シメネジ3.57	SCREW, M3.57	
16	014770622	2	アナトメネジ6.35クボミ	SET SCREW, SOCKET (CP) M6.35	
17	146547000	1	オクリダイカクゴマ	FEED BAR SLIDE BLOCK	
18	148834001	1	シメネジ3.57	SCREW, M3.57	
19	S08931001	1	スプレダタテジク	SPREADER VERTICAL SHAFT	
20	S08932000	1	スプレダタテジクメタル	SPREADER VERTICAL SHAFT BUSH	
21	081007670	1	OリングPW7	O RING, PW7	
22	110197001	1	セットカラー	SET COLLAR	
23	014680422	2	アナトメネジ4.37クボミ	SET SCREW, SOCKET (CP) M4.37	
24	S08933001	1	スプレダホルダ	SPREADER HOLDER	
25	062681412	1	ナベコ437-40X14	SCREW, PAN M4.37-40X14	
26	S28591001	1	スプレダ	SPREADER	
27	062681012	1	ナベコ437-40X10	SCREW, PAN M4.37-40X10	

K1. 糸調子関係 / Thread tension / Fadernspannung / Tension du fil / Tensión del hilo

B256

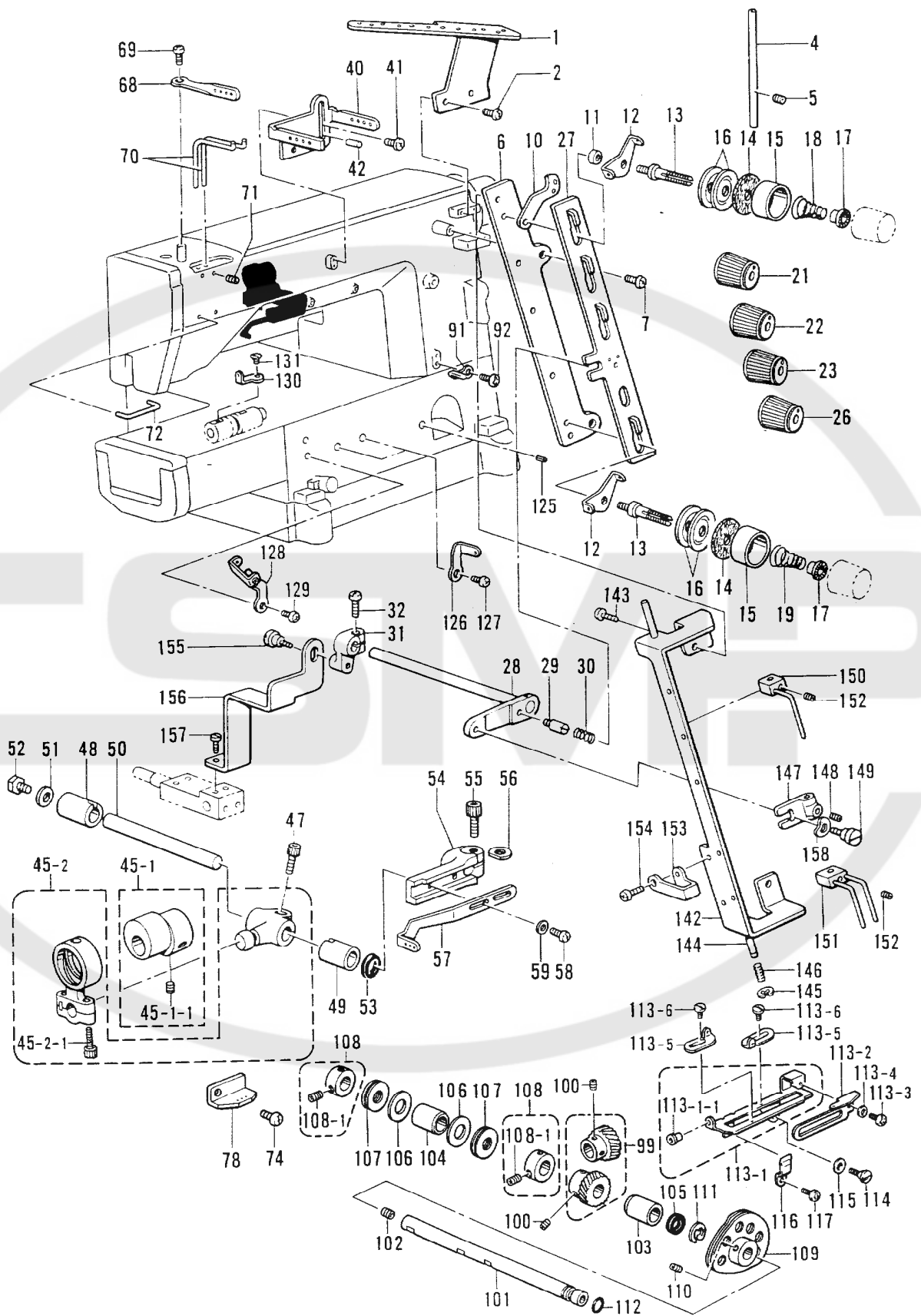

K1. 糸調子関係 / Thread tension / Faderspannung / Tension du fil / Tensión del hilo

REF.NO.	CODE	Q'TY	ヒンメイ	NAME OF PARTS	RM
			<B256>		
1	S08961101	1	シユイトアンナイ	MAIN THREAD GUIDE	
2	062680812	2	ナベコ437-40X8	SCREW, PAN M4.37-40X8	
4	150645009	1	イトアンナイパイプL	THREAD GUIDE PIPE (L)	
5	014680422	1	アナトメネジ4.37クボミ	SET SCREW, SOCKET (CP) M4.37	
6	S08962109	1	イトチヨウシダイ	TENSION BASE	
7	062681012	2	ナベコ437-40X10	SCREW, PAN M4.37-40X10	
10	S08963001	4	イトチヨウシダイイトアンナイ	TENSION BASE THREAD GUIDE	
11	S21878001	4	カンザ	SPACER	
12	110813001	4	ハリイトアンナイ	NEEDLE THREAD GUIDE	
13	159574101	4	イトチヨウシボウ	TENSION STUD	
14	110832009	4	イトチヨウシサラフェルト	TENSION DISC FELT	
15	144103009	4	イトチヨウシサラオサエ	TENSION DISC PRESSER	
16	145446001	8	イトチヨウシサラ	TENSION DISC	
17	S30564000	3	チヨウシバネウエザガネ	TENSION SPRING WASHER	
18	144104001	4	ハリイトチヨウシバネ	THREAD TENSION ADJUST SPRING	
19	144110001	1	シタルーバイトチヨウシバネ	THREAD TENSION ADJUST SPRING	
21	S30565003	1	イトチヨウシナツト (アカ)	TENSION NUT (RED)	
22	S30565004	1	イトチヨウシナツト (キイ)	TENSION NUT (YELLOW)	
23	S30565002	1	イトチヨウシナツト (ミドリ)	TENSION NUT (GREEN)	
26	S30565001	1	イトチヨウシナツト (ミズイロ)	TENSION NUT (LIGHT BLUE)	
27	S21879001	1	イトユルメイタ	TENSION RELEASE PLATE	
28	S21880001	1	イトユルメジク	TENSION RELEASE SHAFT	
29	S21881001	1	シメネジ4.76	SCREW, M4.76	
30	S21882001	1	イトユルメイタオシバネ	SPRING	
31	S21883001	1	イトユルメウデ	TENSION RELEASE ARM	
32	062681212	1	ナベコ437-40X12	SCREW, PAN M4.37-40X12	
40	S08969101	1	チユウカンイトアンナイ	THREAD GUIDE	
41	060680712	1	バインド437-40X7	SCREW, BIND M4.37-40X7	
42	143602001	1	ミゾツキピン	DOWEL PIN	
45	S08971201	1	ハリイトクリヘンシンリンクミ	NEEDLE THREAD TAKE-UP ECCENTRIC ASSY	
45-1	S10657001	1	イトクリヘンシンリンクネジツキ	TAKE-UP ECCENTRIC WHEEL WITH SCREW	
45-1-1	014770622	2	アナトメネジ6.35クボミ	SET SCREW, SOCKET (CP) M6.35	
45-2	S08973101	1	ハリイトクリロツドクミ	THREAD TAKE-UP ECCENTRIC ROD ASSY	
45-2-1	018401422	2	アナボルト4X14	BOLT, SOCKET M4X14	
47	018771432	1	アナボルト635-40X14	BOLT, SOCKET M6.35-40X14	
48	155220000	1	ホジヨアツメタルR	AUTO PRESSER ARM BUSH (R)	
49	S08770000	1	ジクメタル	SHAFT BUSH	
50	S08976001	1	ハリイトクリジク	NEEDLE THREAD TAKE-UP SHAFT	
51	S00356001	1	ザガネ	WASHER	
52	S00383001	1	ボルト5.56X8	BOLT, M5.56X8	
53	155539000	1	ダストシール	DUST SEAL	
54	S08977001	1	ハリイトクリレバー	NEEDLE THREAD TAKE-UP LEVER	
55	018771432	1	アナボルト635-40X14	BOLT, SOCKET M6.35-40X14	
56	155162001	1	スペーサ	SPACER	
57	S08978001	1	ハリイトクリ	NEEDLE THREAD TAKE-UP	
58	062681012	2	ナベコ437-40X10	SCREW, PAN M4.37-40X10	
59	100645003	2	ザガネ	WASHER	
68	S08981001	1	ハリボウテンピン	NEEDLE BAR TAKE-UP	
69	062670612	1	ナベコ357-40X6	SCREW, PAN M3.57-40X6	
70	S08982001	2	ハリイトウケ	NEEDLE THREAD GUIDE	
71	014680422	2	アナトメネジ4.37クボミ	SET SCREW, SOCKET (CP) M4.37	
72	S08983001	1	アームハリイトウケ	ARM NEEDLE THREAD GUIDE	
74	062680812	1	ナベコ437-40X8	SCREW, PAN M4.37-40X8	
78	S28438001	1	アームイトアンナイD	ARM THREAD GUIDE (D)	
91	S08970001	1	イトアンナイS	THREAD GUIDE (S)	
92	062680612	1	ナベコ4.37-40X6	SCREW, PAN M4.37-40X6	
99	S28417001	1	ヘリカルギヤクミ	HELICAL GEAR ASSY	
100	014770622	4	アナトメネジ6.35クボミ	SET SCREW, SOCKET (CP) M6.35	
101	S28420001	1	テンピンジク	TAKE-UP SHAFT	

K1. 糸調子関係 / Thread tension / Faderspannung / Tension du fil / Tensión del hilo

B256

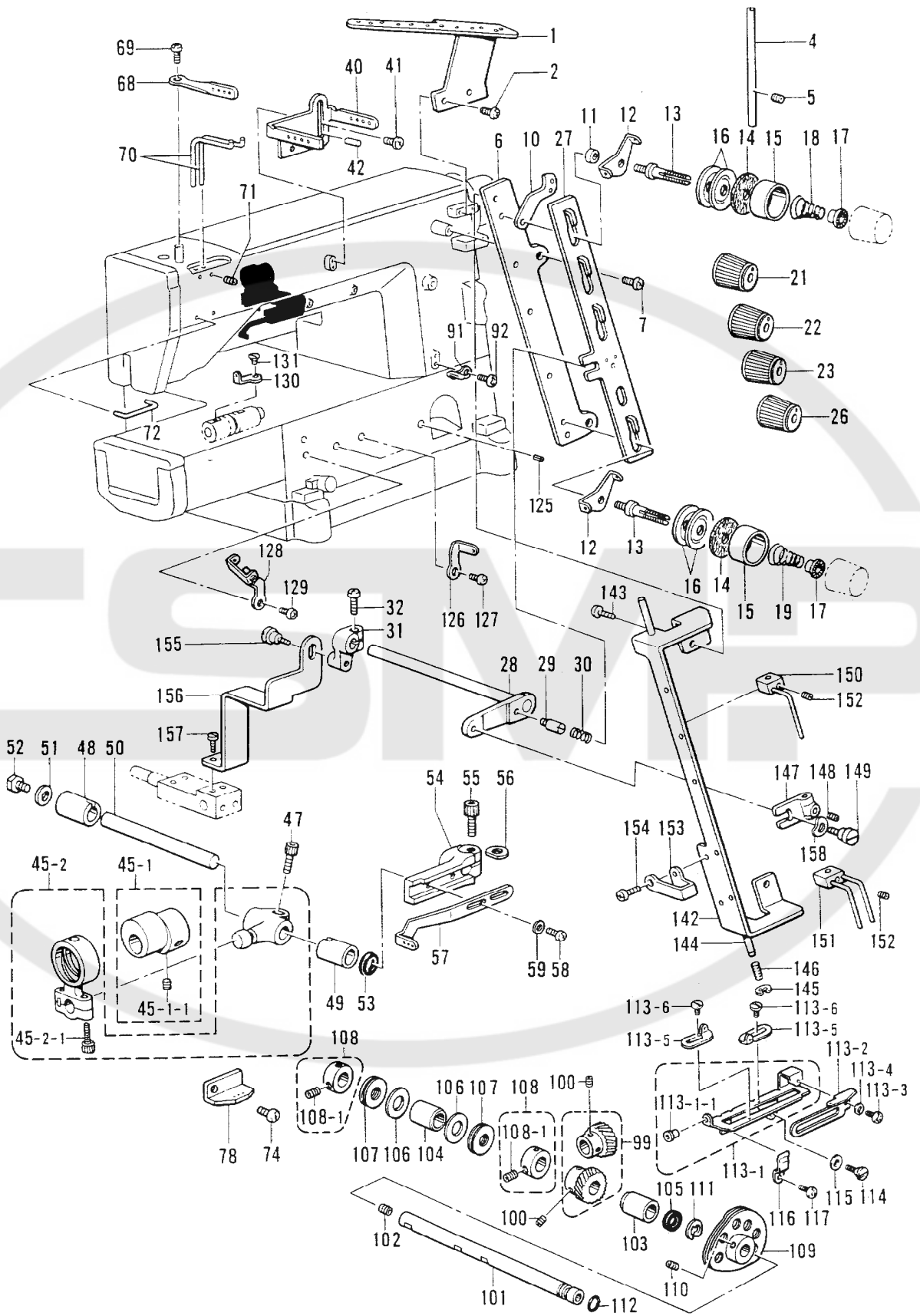

K1. 糸調子関係 / Thread tension / Faderspannung / Tension du fil / Tensión del hilo

REF.NO.	CODE	Q'TY	ヒンメイ	NAME OF PARTS	RM
102	014770622	1	アナトメネジ6.35クボミ	SET SCREW, SOCKET (CP) M6.35	
103	S28421000	1	テンビンジクメタルF	TAKE-UP SHAFT BUSH (F)	
104	S28422000	1	テンビンジクメタルB	TAKE-UP SHAFT BUSH (B)	
105	S28423000	1	ダストシール	DUST SEAL	
106	S28424001	2	スラストザガネ	THRUST WASHER	
107	S08238000	2	スラストベアリング	THRUST BEARING	
108	S28425001	2	セツトカラークミ	SET COLLAR ASSY	
108-1	014770622	4	アナトメネジ6.35クボミ	SET SCREW, SOCKET (CP) M6.35	
109	S28427001	1	シタイトテンビンクミ	LOOPER THREAD TAKE-UP ASSY	
110	014680422	2	アナトメネジ4.37クボミ	SET SCREW, SOCKET (CP) M4.37	
111	048090342	1	トメワE9	RETAINING RING, E9	
112	081008070	1	OリングP8	O RING, P8	
113	S28796001	1	テンビンドダイソウクミ	LOOPER THREAD TAKE-UP BASE SET	
113-1	S28431001	1	テンビンドダイクミ	LOOPER THREAD TAKE-UP BASE ASSY	
113-1-1	146924000	1	スレッドブツシユ	THREAD BUSH	
113-2	S28434001	1	テンビンイトサバキ	THREAD HANDLER	
113-3	062670612	1	ナベコ357-40X6	SCREW, PAN M3.57-40X6	
113-4	105161004	1	ザガネ	WASHER	
113-5	S28435001	2	テンビンイトアンナイ	TAKE-UP THREAD GUIDE	
113-6	105288001	2	シメネジ2.38	SCREW, M2.38	
114	S08777001	1	ダンネジ4.37	STUD SCREW, M4.37	
115	103810002	1	ナミガタバネザガネ	WAVE SPRING WASHER	
116	155318001	1	ドダイオサエバネ	SPRING	
117	062670612	1	ナベコ357-40X6	SCREW, PAN M3.57-40X6	
125	047200642	1	スプリングピンAW2	PIN, SPRING ROLL AW2	
126	S08970001	2	イトアンナイS	THREAD GUIDE (S)	
127	062680612	2	ナベコ4.37-40X6	SCREW, PAN M4.37-40X6	
128	S28436001	1	シタイトアンナイF	LOOPER THREAD GUIDE (F)	
129	062680612	1	ナベコ4.37-40X6	SCREW, PAN M4.37-40X6	
130	S28437001	1	シタイトアンナイB	LOOPER THREAD GUIDE (B)	
131	149288003	1	サラネジ3.18	SCREW, FLAT M3.18	
142	S21884001	1	イトユルメアンナイ	TENSION RELEASE GUIDE	
143	060680512	2	バインド437-40X5	SCREW, BIND M4.37-40X5	
144	S21885001	1	イトトリジク	THREAD TAKE-UP SHAFT	
145	048030342	1	トメワE3	RETAINING RING, E3	
146	S21886001	1	カンシヨウバネ	SHOCK ABSORBING SPRING	
147	S21887001	1	イトトリレバー	THREAD TAKE-UP LEVER	
148	014680422	1	アナトメネジ4.37クボミ	SET SCREW, SOCKET (CP) M4.37	
149	144526001	1	ダンネジ4.37	STUD SCREW, M4.37	
150	S21888001	3	イトトリブロックSクミ	THREAD TAKE-UP BLOCK (S) ASSY	
151	S21891001	1	イトトリブロックWクミ	THREAD TAKE-UP BLOCK (W) ASSY	
152	014680422	4	アナトメネジ4.37クボミ	SET SCREW, SOCKET (CP) M4.37	
153	S21893001	1	イトユルメイトミチ	THREAD HANDLING AREA	
154	062670512	1	ナベコ357-40X5	SCREW, PAN M3.57-40X5	
155	144526001	1	ダンネジ4.37	STUD SCREW, M4.37	
156	S21894001	1	イトユルメクドウイタ	TENSION RELEASE DRIVING PLATE	
157	100644005	2	シメネジ4.37	SCREW, M4.37	
158	103810002	1	ナミガタバネザガネ	WAVE SPRING WASHER	

K2. 糸調子関係 / Thread tension / Faderspannung / Tension du fil / Tensión del hilo

B257

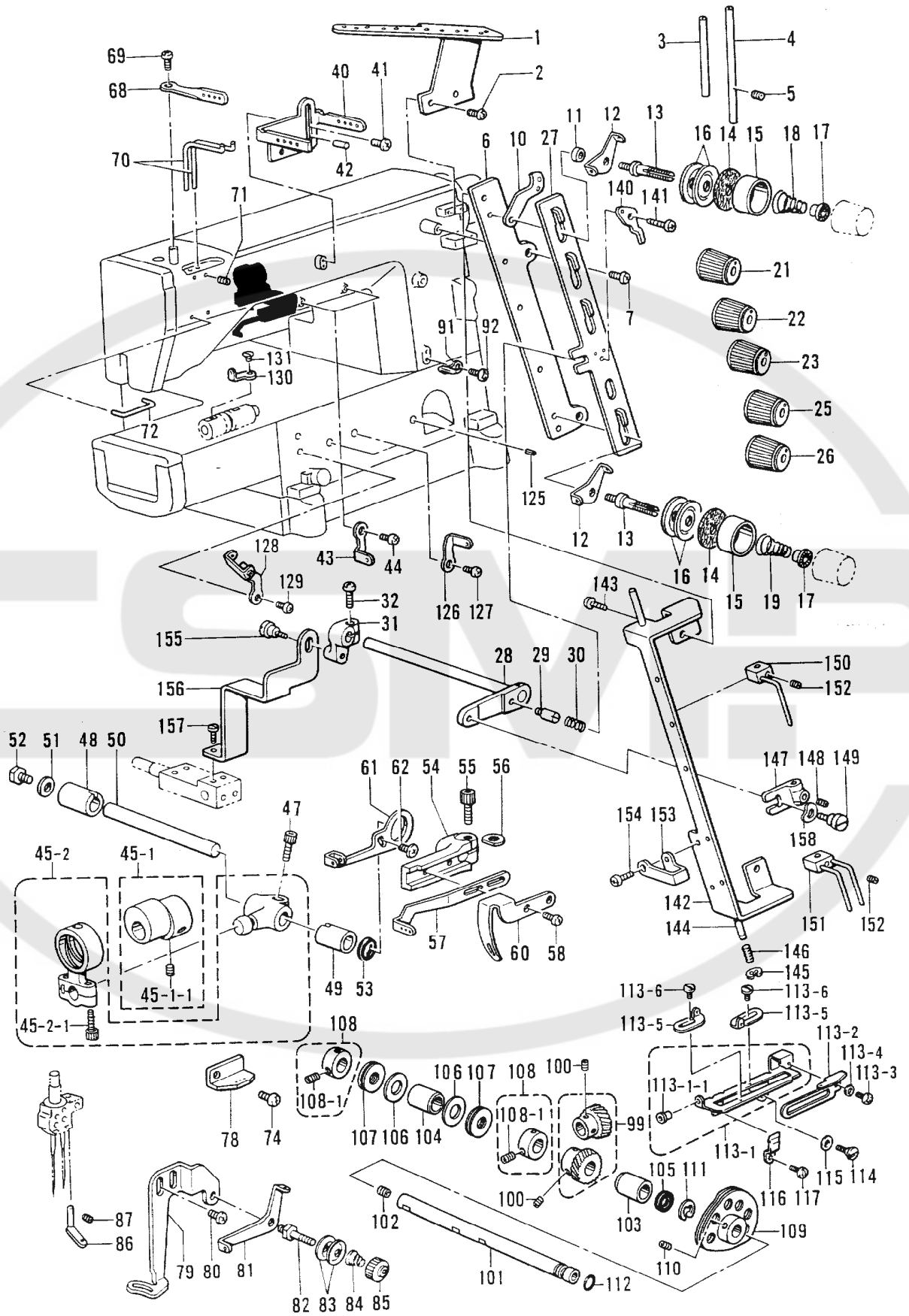

K2. 糸調子関係 / Thread tension / Faderspannung / Tension du fil / Tensión del hilo

REF.NO.	CODE	Q'TY	ヒンメイ	NAME OF PARTS	RM
			<B257>		
1	S08961101	1	シユイトアンナイ	MAIN THREAD GUIDE	
2	062680812	2	ナベコ437-40X8	SCREW, PAN M4.37-40X8	
3	150644009	1	イトアンナイパイプS	THREAD GUIDE PIPE (S)	
4	150645009	1	イトアンナイパイプL	THREAD GUIDE PIPE (L)	
5	014680422	2	アナトメネジ4.37クボミ	SET SCREW, SOCKET (CP) M4.37	
6	S08962109	1	イトチヨウシダイ	TENSION BASE	
7	062681012	2	ナベコ437-40X10	SCREW, PAN M4.37-40X10	
10	S08963001	5	イトチヨウシダイイトアンナイ	TENSION BASE THREAD GUIDE	
11	S21878001	5	カンザ	SPACER	
12	110813001	5	ハリイトアンナイ	NEEDLE THREAD GUIDE	
13	159574101	5	イトチヨウシボウ	TENSION STUD	
14	110832009	5	イトチヨウシサラフェルト	TENSION DISC FELT	
15	144103009	5	イトチヨウシサラオサエ	TENSION DISC PRESSER	
16	145446001	10	イトチヨウシサラ	TENSION DISC	
17	S30564000	5	チヨウシバナウエザガネ	TENSION SPRING WASHER	
18	144104001	3	ハリイトチヨウシバナ	THREAD TENSION ADJUST SPRING	
19	144110001	2	シタルーパイトチヨウシバナ	THREAD TENSION ADJUST SPRING	
21	S30565003	1	イトチヨウシナツト (アカ)	TENSION NUT (RED)	
22	S30565004	1	イトチヨウシナツト (キイ)	TENSION NUT (YELLOW)	
23	S30565002	1	イトチヨウシナツト (ミドリ)	TENSION NUT (GREEN)	
25	S30565003	1	イトチヨウシナツト (アカ)	TENSION NUT (RED)	
26	S30565001	1	イトチヨウシナツト (ミズイロ)	TENSION NUT (LIGHT BLUE)	
27	S21879001	1	イトユルメイタ	TENSION RELEASE PLATE	
28	S21880001	1	イトユルメジク	TENSION RELEASE SHAFT	
29	S21881001	1	シメネジ4.76	SCREW, M4.76	
30	S21882001	1	イトユルメイタオシバナ	SPRING	
31	S21883001	1	イトユルメウデ	TENSION RELEASE ARM	
32	062681212	1	ナベコ437-40X12	SCREW, PAN M4.37-40X12	
40	S08969101	1	チユウカンイトアンナイ	THREAD GUIDE	
41	060680712	1	バインド437-40X7	SCREW, BIND M4.37-40X7	
42	143602001	1	ミゾツキピン	DOWEL PIN	
43	S08970001	2	イトアンナイS	THREAD GUIDE (S)	
44	062680612	2	ナベコ4.37-40X6	SCREW, PAN M4.37-40X6	
45	S08971201	1	ハリイトクリヘンシンリンクミ	NEEDLE THREAD TAKE-UP ECCENTRIC ASSY	
45-1	S10657001	1	イトクリヘンシンリンクネジツキ	TAKE-UP ECCENTRIC WHEEL WITH SCREW	
45-1-1	014770622	2	アナトメネジ6.35クボミ	SET SCREW, SOCKET (CP) M6.35	
45-2	S08973101	1	ハリイトクリロツドクミ	THREAD TAKE-UP ECCENTRIC ROD ASSY	
45-2-1	018401422	2	アナボルト4X14	BOLT, SOCKET M4X14	
47	018771432	1	アナボルト635-40X14	BOLT, SOCKET M6.35-40X14	
48	155220000	1	ホジヨアツメタルR	AUTO PRESSER ARM BUSH (R)	
49	S08770000	1	ジクメタル	SHAFT BUSH	
50	S08976001	1	ハリイトクリジク	NEEDLE THREAD TAKE-UP SHAFT	
51	S00356001	1	ザガネ	WASHER	
52	S00383001	1	ボルト5.56X8	BOLT, M5.56X8	
53	155539000	1	ダストシール	DUST SEAL	
54	S08977001	1	ハリイトクリレバー	NEEDLE THREAD TAKE-UP LEVER	
55	018771432	1	アナボルト635-40X14	BOLT, SOCKET M6.35-40X14	
56	155162001	1	スベーサ	SPACER	
57	S08978001	1	ハリイトクリ	NEEDLE THREAD TAKE-UP	
58	062681012	2	ナベコ437-40X10	SCREW, PAN M4.37-40X10	
60	S08979001	1	カザリイトクリ	COVERING THREAD TAKE-UP	
61	S08980001	1	カザリイトアンナイR	COVERING THREAD GUIDE (R)	
62	060680712	1	バインド437-40X7	SCREW, BIND M4.37-40X7	
68	S08981001	1	ハリボウテンピン	NEEDLE BAR TAKE-UP	
69	062670612	1	ナベコ357-40X6	SCREW, PAN M3.57-40X6	
70	S08982001	2	ハリイトウケ	NEEDLE THREAD GUIDE	
71	014680422	2	アナトメネジ4.37クボミ	SET SCREW, SOCKET (CP) M4.37	
72	S08983001	1	アームハリイトウケ	ARM NEEDLE THREAD GUIDE	
74	062680812	1	ナベコ437-40X8	SCREW, PAN M4.37-40X8	
78	S28438001	1	アームイトアンナイD	ARM THREAD GUIDE (D)	
79	S08985001	1	カザリイトアンナイL	COVERING THREAD GUIDE (L)	

K2. 糸調子関係 / Thread tension / Faderspannung / Tension du fil / Tensión del hilo

B257

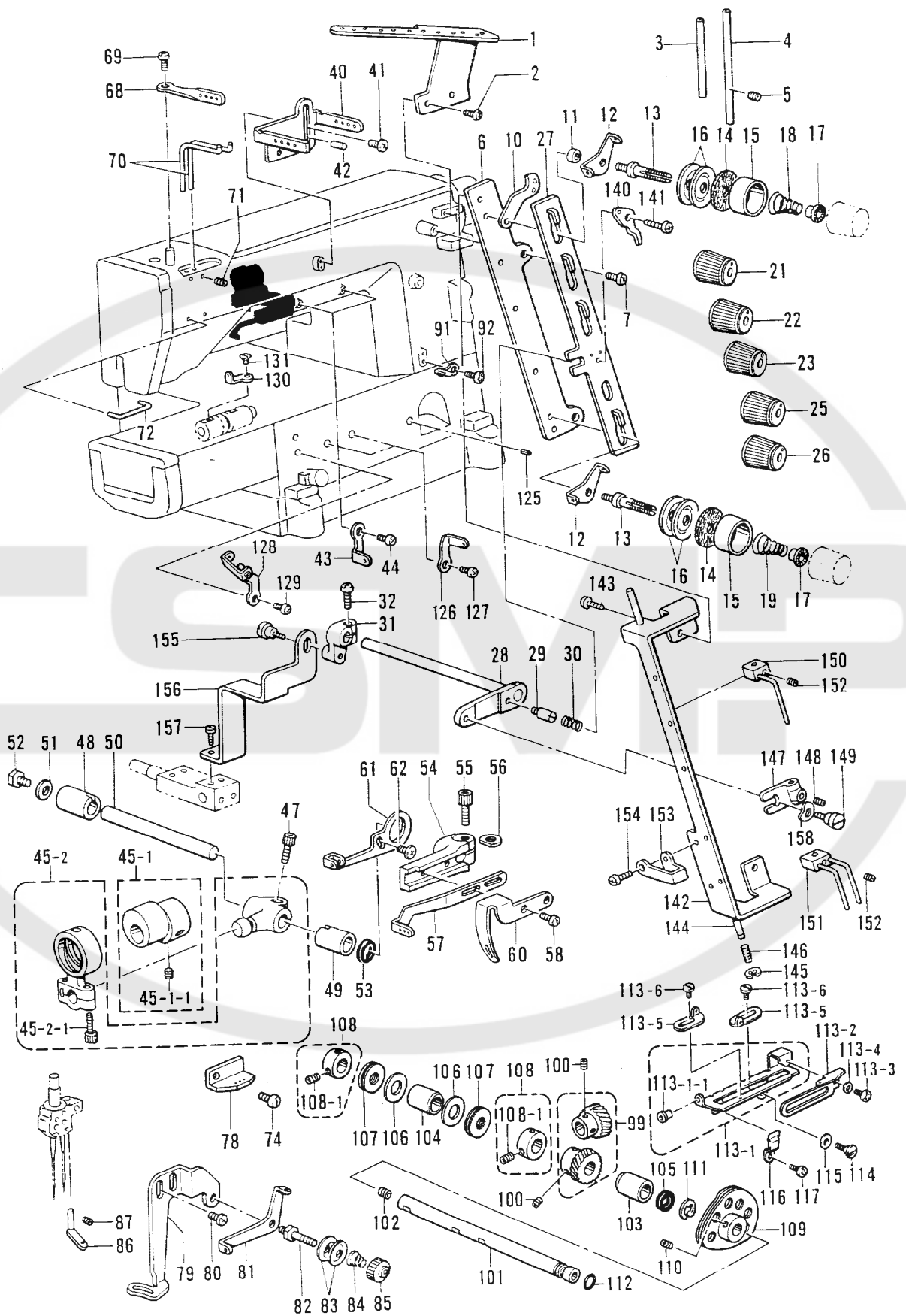

K2. 糸調子関係 / Thread tension / Faderspannung / Tension du fil / Tensión del hilo

REF.NO.	CODE	Q'TY	ヒンメイ	NAME OF PARTS	RM
80	060680712	2	バインド437-40X7	SCREW, BIND M4.37-40X7	
81	S08986001	1	カザリイトアンナイ	COVERING THREAD GUIDE	
82	S08987001	1	イトチヨウシボウ	THREAD TENSION CONTROL STUD	
83	144504001	2	イトアンナイサラ	THREAD GUIDE DISC	
84	144505000	1	イトアンナイバネ	SPRING	
85	155510001	1	イトチヨウシナツト	TENSION NUT	
86	S08988001	1	ハリドメカザリイトアンナイ	NEEDLE CLAMP THREAD GUIDE	
87	146427001	1	アナトメネジ3.18クボミ	SET SCREW, SOCKET (CP) M3.18	
91	S08970001	1	イトアンナイS	THREAD GUIDE (S)	
92	062680612	1	ナベコ4.37-40X6	SCREW, PAN M4.37-40X6	
99	S28417001	1	ヘリカルギヤクミ	HELICAL GEAR ASSY	
100	014770622	4	アナトメネジ6.35クボミ	SET SCREW, SOCKET (CP) M6.35	
101	S28420001	1	テンビンジク	TAKE-UP SHAFT	
102	014770622	1	アナトメネジ6.35クボミ	SET SCREW, SOCKET (CP) M6.35	
103	S28421000	1	テンビンジクメタルF	TAKE-UP SHAFT BUSH (F)	
104	S28422000	1	テンビンジクメタルB	TAKE-UP SHAFT BUSH (B)	
105	S28423000	1	ダストシール	DUST SEAL	
106	S28424001	2	スラストザガネ	THRUST WASHER	
107	S08238000	2	スラストベアリング	THRUST BEARING	
108	S28425001	2	セツトカラークミ	SET COLLAR ASSY	
108-1	014770622	4	アナトメネジ6.35クボミ	SET SCREW, SOCKET (CP) M6.35	
109	S28427001	1	シタイトテンビンクミ	LOOPER THREAD TAKE-UP ASSY	
110	014680422	2	アナトメネジ4.37クボミ	SET SCREW, SOCKET (CP) M4.37	
111	048090342	1	トメワE9	RETAINING RING, E9	
112	081008070	1	OリングP8	O RING, P8	
113	S28796001	1	テンビンドダイソウクミ	LOOPER THREAD TAKE-UP BASE SET	
113-1	S28431001	1	テンビンドダイクミ	LOOPER THREAD TAKE-UP BASE ASSY	
113-1-1	146924000	1	スレツドブツシュ	THREAD BUSH	
113-2	S28434001	1	テンビンイトサバキ	THREAD HANDLER	
113-3	062670612	1	ナベコ357-40X6	SCREW, PAN M3.57-40X6	
113-4	105161004	1	ザガネ	WASHER	
113-5	S28435001	2	テンビンイトアンナイ	TAKE-UP THREAD GUIDE	
113-6	105288001	2	シメネジ2.38	SCREW, M2.38	
114	S08777001	1	ダンネジ4.37	STUD SCREW, M4.37	
115	103810002	1	ナミガタバネザガネ	WAVE SPRING WASHER	
116	155318001	1	ドダイオサエバネ	SPRING	
117	062670612	1	ナベコ357-40X6	SCREW, PAN M3.57-40X6	
125	047200642	1	スプリングピンAW2	PIN, SPRING ROLL AW2	
126	S08970001	2	イトアンナイS	THREAD GUIDE (S)	
127	062680612	2	ナベコ4.37-40X6	SCREW, PAN M4.37-40X6	
128	S28436001	1	シタイトアンナイF	LOOPER THREAD GUIDE (F)	
129	062680612	1	ナベコ4.37-40X6	SCREW, PAN M4.37-40X6	
130	S28437001	1	シタイトアンナイB	LOOPER THREAD GUIDE (B)	
131	149288003	1	サラネジ3.18	SCREW, FLAT M3.18	
140	S21963001	1	イトユルメイタS	TENSION RELEASE PLATE (S)	
141	060680512	1	バインド437-40X5	SCREW, BIND M4.37-40X5	
142	S21884001	1	イトユルメアンナイ	TENSION RELEASE GUIDE	
143	060680512	2	バインド437-40X5	SCREW, BIND M4.37-40X5	
144	S21885001	1	イトトリジク	THREAD TAKE-UP SHAFT	
145	048030342	1	トメワE3	RETAINING RING, E3	
146	S21886001	1	カンシヨウバネ	SHOCK ABSORBING SPRING	
147	S21887001	1	イトトリレバー	THREAD TAKE-UP LEVER	
148	014680422	1	アナトメネジ4.37クボミ	SET SCREW, SOCKET (CP) M4.37	
149	144526001	1	ダンネジ4.37	STUD SCREW, M4.37	
150	S21888001	3	イトトリブロツクSクミ	THREAD TAKE-UP BLOCK (S) ASSY	
151	S21891001	2	イトトリブロツクWクミ	THREAD TAKE-UP BLOCK (W) ASSY	
152	014680422	5	アナトメネジ4.37クボミ	SET SCREW, SOCKET (CP) M4.37	
153	S21893001	2	イトユルメイトミチ	THREAD HANDLING AREA	
154	062670512	2	ナベコ357-40X5	SCREW, PAN M3.57-40X5	
155	144526001	1	ダンネジ4.37	STUD SCREW, M4.37	
156	S21894001	1	イトユルメクドウイタ	TENSION RELEASE DRIVING PLATE	
157	100644005	2	シメネジ4.37	SCREW, M4.37	
158	103810002	1	ナミガタバネザガネ	WAVE SPRING WASHER	

L. ラッパ関係 / Lapper mechanism / Falz-mechanismus /
 Mécanisme à rabat / Mecanismo de solapado

B257-0V1

三ツ折 / Clean finish top and raw edge bottom

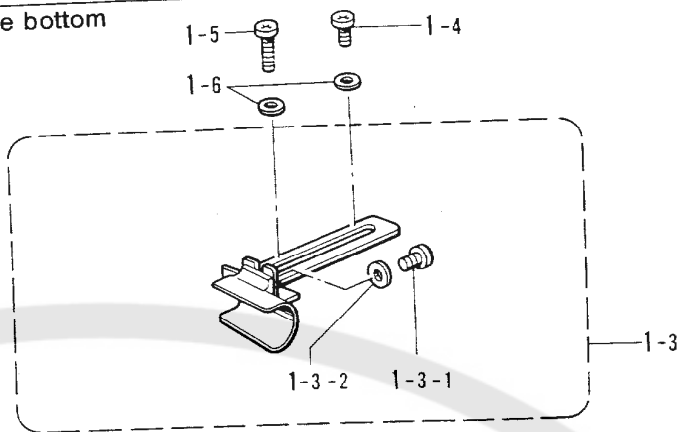

30mm

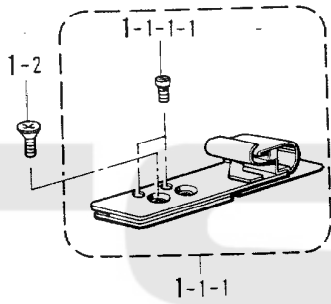

35mm
 <標準 / STANDARD >

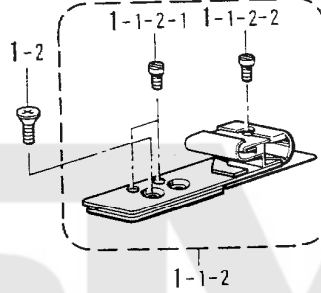

40mm

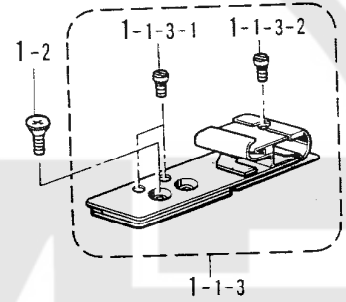

二ツ折 / Raw edge top and bottom

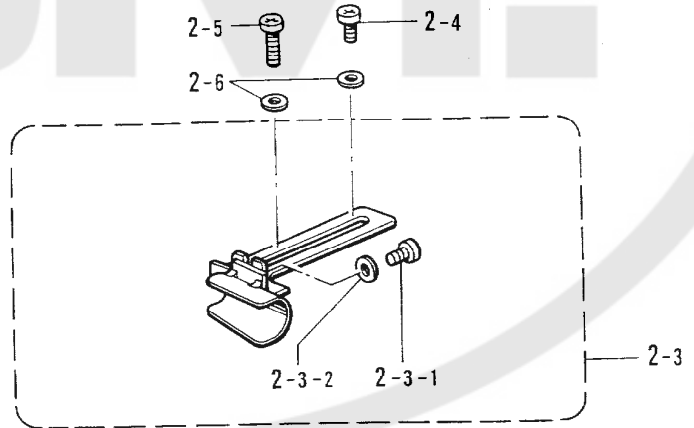

30mm

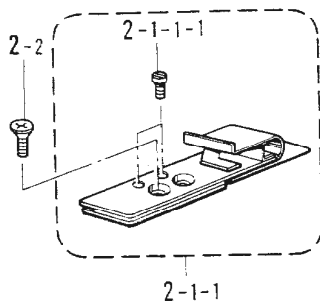

35mm

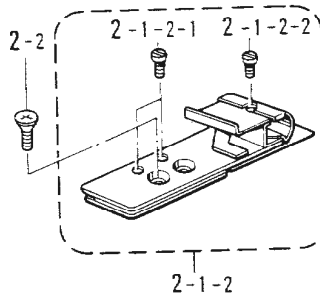

40mm

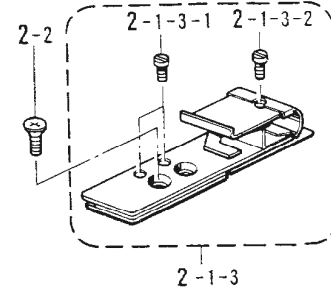

L. ラッパ-関係 / Lapper mechanism / Falz-mechanismus /
Mécanisme à rabat / Mecanismo de solapado

REF.NO.	CODE	Q'TY	ヒンメイ	NAME OF PARTS	RM
<B257-0V1>					
<三つ折り / CLEAN FINISH TOP AND FAW EDGE BOTTOM>					
1-2	003400804	2	サラネジ4X8	SCREW, FLAT M4X8	
1-3	S28606001	1	ゴムガイドRクミ	RUBBER GUIDE (R) ASSY	
1-3-1	062670412	1	ナベコ357-40X4	SCREW, PAN M3.57-40X4	
1-3-2	105161004	1	ザガネ	WASHER	
1-4	062710612	1	ナベコ476-32X6	SCREW, PAN M4.76-32X6	
1-5	062711212	1	ナベコ476-32X12	SCREW, PAN M4.76-32X12	
1-6	148847001	2	ザガネ	WASHER	
<30MM>					
1	S28601001	1	ゴムバインダークミ	RUBBER BINDER ASSY	
1-1-1	S28602001	1	ゴムガイドLクミ	RUBBER GUIDE (L) ASSY	
1-1-1-1	141544001	2	シメネジ3.18	SCREW, M3.18	
<35MM> <標準 / STANDARD>					
1	S28609001	1	ゴムバインダークミ	RUBBER BINDER ASSY	
1-1-2	S28610001	1	ゴムガイドLクミ	RUBBER GUIDE (L) ASSY	
1-1-2-1	141544001	2	シメネジ3.18	SCREW, M3.18	
1-1-2-2	110215002	1	シメネジ3.57	SCREW, M3.57	
<40MM>					
1	S28614001	1	ゴムバインダークミ	RUBBER BINDER ASSY	
1-1-3	S28615001	1	ゴムガイドLクミ	RUBBER GUIDE (L) ASSY	
1-1-3-1	141544001	2	シメネジ3.18	SCREW, M3.18	
1-1-3-2	110215002	1	シメネジ3.57	SCREW, M3.57	
<二つ折り / RAW EDGE TOP AND BOTTOM>					
2-2	003400804	2	サラネジ4X8	SCREW, FLAT M4X8	
2-3	S28604001	1	ゴムガイドRクミ	RUBBER GUIDE (R) ASSY	
2-3-1	062670412	1	ナベコ357-40X4	SCREW, PAN M3.57-40X4	
2-3-2	105161004	1	ザガネ	WASHER	
2-4	062710612	1	ナベコ476-32X6	SCREW, PAN M4.76-32X6	
2-5	062711212	1	ナベコ476-32X12	SCREW, PAN M4.76-32X12	
2-6	148847001	2	ザガネ	WASHER	
<30MM>					
2	S28619001	1	ゴムバインダークミ	RUBBER BINDER ASSY	
2-1-1	S28620001	1	ゴムガイドLクミ	RUBBER GUIDE (L) ASSY	
2-1-1-1	141544001	2	シメネジ3.18	SCREW, M3.18	
<35MM>					
2	S28622001	1	ゴムバインダークミ	RUBBER BINDER ASSY	
2-1-2	S28623001	1	ゴムガイドLクミ	RUBBER GUIDE (L) ASSY	
2-1-2-1	141544001	2	シメネジ3.18	SCREW, M3.18	
2-1-2-2	110215002	1	シメネジ3.57	SCREW, M3.57	
<40MM>					
2	S28625001	1	ゴムバインダークミ	RUBBER BINDER ASSY	
2-1-3	S28626001	1	ゴムガイドLクミ	RUBBER GUIDE (L) ASSY	
2-1-3-1	141544001	2	シメネジ3.18	SCREW, M3.18	
2-1-3-2	110215002	1	シメネジ3.57	SCREW, M3.57	

M. プーラ装置関係 / Puller device mechanism / Ziehvorrichtung /
 Mécanisme due puller / Mecanismo del dispositivo de arrastre

056
 061
 OV1

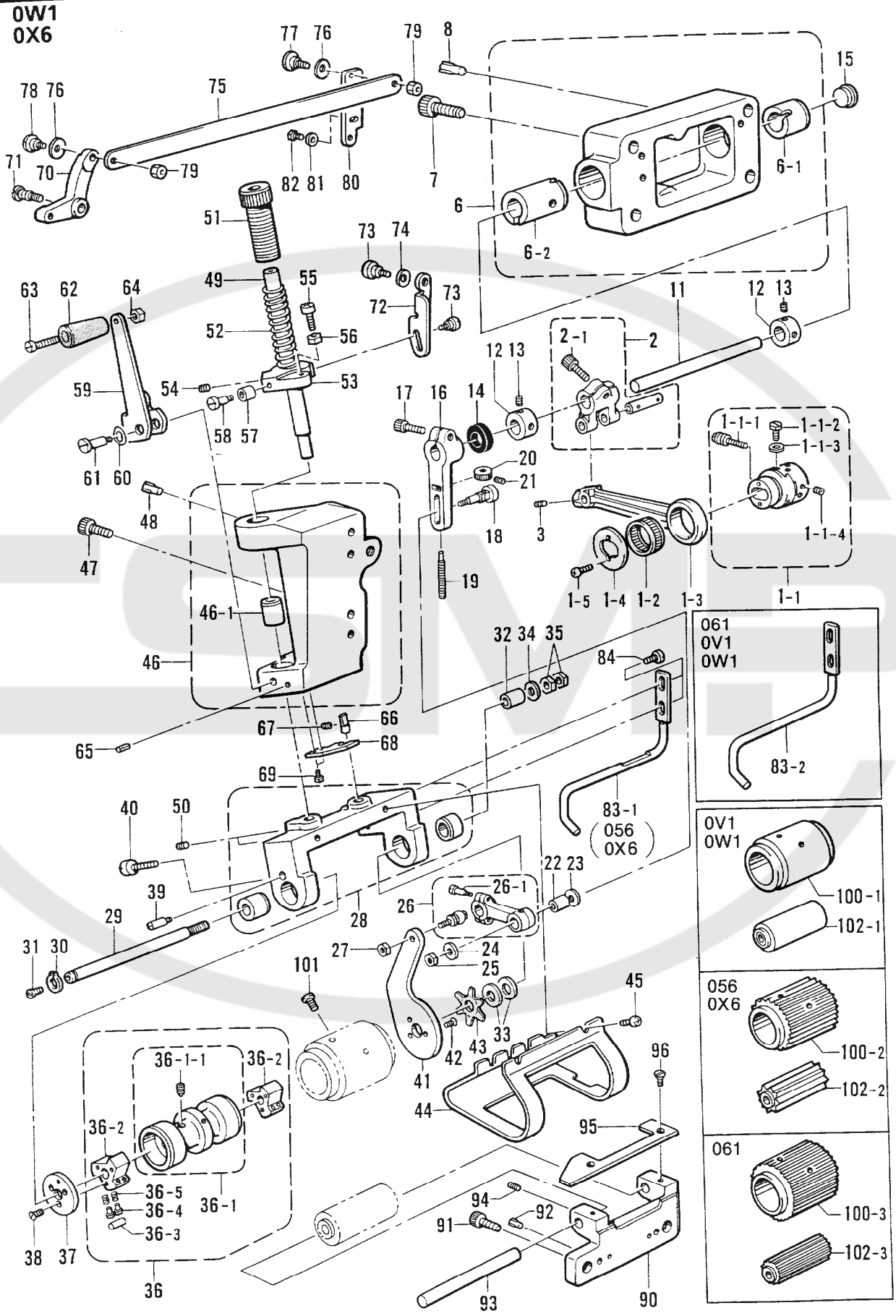

- 061
 OV1
 OW1
 83-2
- OV1
 OW1
 100-1
 102-1
- 056
 OX6
 100-2
 102-2
- 061
 100-3
 102-3

M. プーラ装置関係 / Puller device mechanism / Ziehvorrichtung /
Mécanisme due puller / Mecanismo del dispositivo de arrastre

REF.NO.	CODE	Q'TY	ヒンメイ	NAME OF PARTS	RM
			<056,061,0V1,0W1,0X6>		
1	S13414201	1	プーラヘンシンリンロットクミ	PULLER ECCENTRIC WHEEL ROD ASSY	
1-1	S12913201	1	プーラヘンシンリンクミ	PULLER ECCENTRIC WHEEL ASSY	
1-1-1	113644001	1	ヘンシンリンチヨウセツネジ	ADJUST SCREW	
1-1-2	144075001	2	ボルト3.57	BOLT, M3.57	
1-1-3	105161004	2	ザガネ	WASHER	
1-1-4	014760622	3	アナトメネジ5.95	SET SCREW, SOCKET (CP) M5.95	
1-2	S12915001	1	ニードルジクウケ25	NEEDLE ROLLER BEARING 25	
1-3	S12916001	1	プーラロッド	PULLER ROD	
1-4	S12821001	1	レンカンオサエ	CONNECTING ROD PRESSER	
1-5	062630612	2	ナベコ238-56X6	SCREW, PAN M2.38-56X6	
2	S17773001	1	クランクジクウデピンクミ	CRANK LEVER PIN ASSY	
2-1	018771432	1	アナボルト635-40X14	BOLT, SOCKET M6.35-40X14	
3	014770622	1	アナトメネジ6.35クボミ	SET SCREW, SOCKET (CP) M6.35	
6	S28250001	1	プーラブラケットRクミ	PULLER BRACKET (R) ASSY	
6-1	148120000	1	クランクジクメタルR	CRANK SHAFT BUSH (R)	
6-2	S28252000	1	プーラドウジクメタルL	PULLER DRIVING SHAFT BUSH (L)	
7	018063022	4	アナボルト6X30	BOLT, SOCKET M6X30	
8	117608001	2	ミゾツキピン	DOWEL PIN	
11	S28253001	1	プーラドウジク	PULLER DRIVING SHAFT	
12	140092001	2	セツトカラー	SET COLLAR	
13	014680422	4	アナトメネジ4.37クボミ	SET SCREW, SOCKET (CP) M4.37	
14	S12918000	1	ダストシール	DUST SEAL	
15	159150009	1	カマジクメクラセン	OIL CAP	
16	S12919001	1	プーラドウレバー	PULLER DRIVING LEVER	
17	018061622	1	アナボルト6X16	BOLT, SOCKET M6X16	
18	S12920001	1	プーラレンカンジク	PULLER CONNECTING SHAFT	
19	S12921001	1	チヨウセツネジ	ADJUST SCREW	
20	S12922001	1	ツマミ	KNOB	
21	148294001	1	アナトメネジ3.57クボミ	SET SCREW, SOCKET (CP) M3.57	
22	S12923001	1	レンカンスリーブ	CONNECTING ROD SLEEVE	
23	156265001	1	ザガネ	WASHER	
24	107453001	1	ザガネ	WASHER	
25	110140001	1	ナット5.56	NUT, M5.56	
26	S12924001	1	プーラレンカンクミ	PULLER CONNECTING ROD ASSY	
26-1	100526003	2	ダンネジ3.57	STUD SCREW, M3.57	
27	110140001	1	ナット5.56	NUT, M5.56	
28	S28254001	1	プーラフレームクミ	PULLER FRAME ASSY	
29	S28256001	1	プーラジク	PULLER SHAFT	
30	048090142	1	トメワジクヨウC9	RETAINING RING, C9	
31	107272002	1	サラネジ4.37	SCREW, FLAT M4.37	
32	S12933001	1	プーラブツシュ	PULLER BUSH	
33	S02556001	2	ザガネ	WASHER	
34	107153001	1	ザガネ	WASHER	
35	105812003	2	ナット7.94	NUT, M7.94	
36	S12934101	1	プーラクラツチクミ	PULLER CLUTCH ASSY	
36-1	S13415101	1	プーラークラツチシユウクミ	PULLER CLUTCH SHOE ASSY	
36-1-1	118853001	1	アナトメネジ5.95	SET SCREW, SOCKET M5.95	
36-2	S09039001	2	クラツチツメ	CLUTCH CLAW	
36-3	150604101	6	コロ	ROLLER	
36-4	150605001	12	クラツチピン	CLUTCH PIN	
36-5	S12900001	12	クラツチバネ	SPRING	
37	S12936001	1	クラツチイタ	CLUTCH PLATE	
38	106128004	3	サラネジ3.57	SCREW, FLAT M3.57	
39	S12937101	1	スタッド	STUD	
40	121007001	1	アタマツキトメネジ4.37	SET SCREW, M4.37	
41	S28334001	1	クラツチレバー	CLUTCH LEVER	
42	106128004	3	サラネジ3.57	SCREW, FLAT M3.57	
43	S12939001	1	ホシガタバネ	SPRING	
44	S28260001	1	プーラガード	PULLER GUARD	
45	062680612	4	ナベコ4.37-40X6	SCREW, PAN M4.37-40X6	

M. プーラ装置関係 / Puller device mechanism / Ziehvorrichtung /
 Mécanisme due puller / Mecanismo del dispositivo de arrastre

056
 061
 OV1

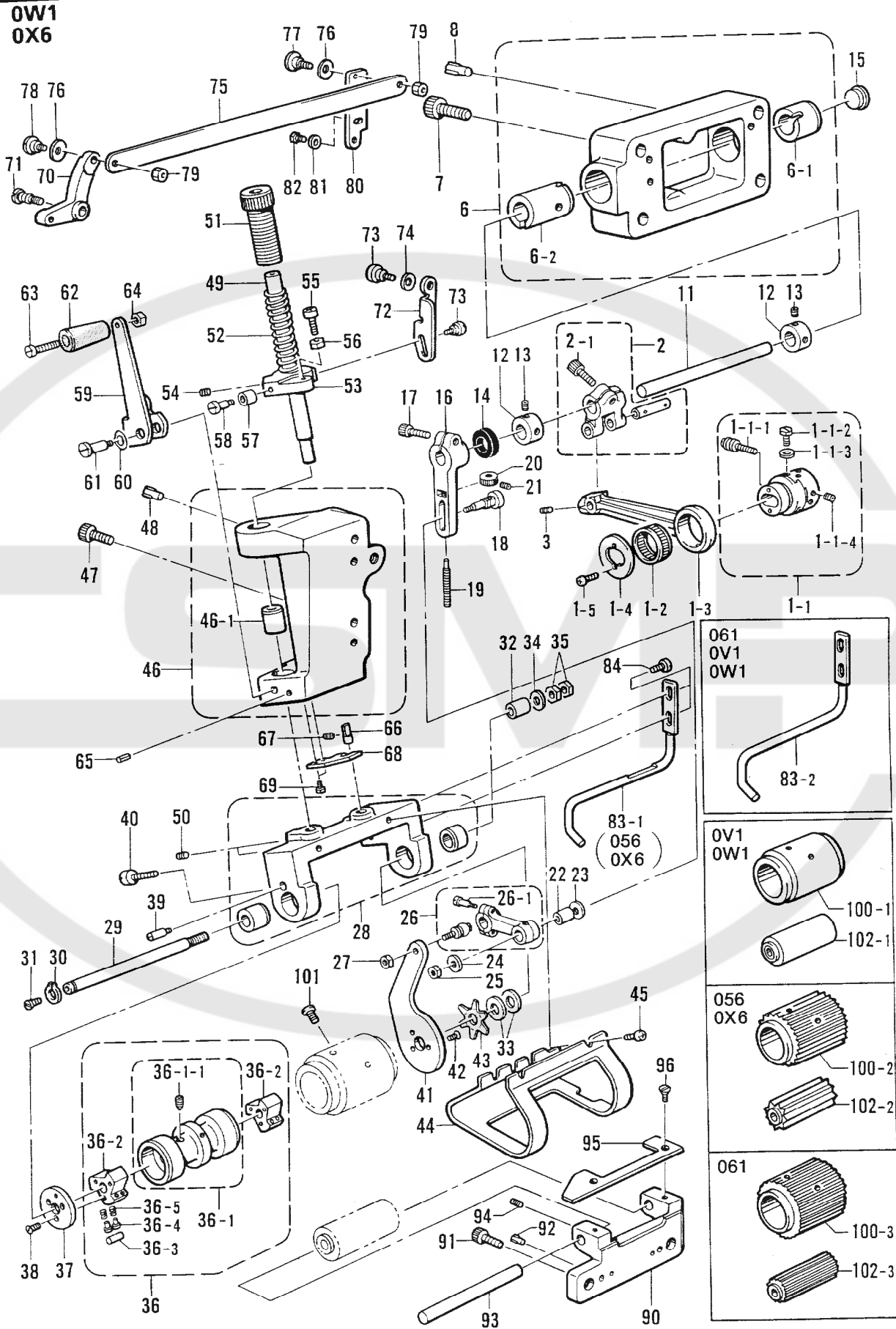

M. プーラ装置関係 / Puller device mechanism / Ziehvorrichtung /
Mécanisme due puller / Mecanismo del dispositivo de arrastre

REF.NO.	CODE	Q'TY	ヒンメイ	NAME OF PARTS	RM
46	S28261001	1	プーラブラケットLクミ	PULLER BRACKET (L) ASSY	
46-1	S12858000	1	リテーナジクメタルF	RETAINER SHAFT BUSH (F)	
47	018061622	2	アナボルト6X16	BOLT, SOCKET M6X16	
48	117608001	2	ミゾツキピン	DOWEL PIN	
49	S12942001	1	プーラオサエボウ	PULLER PRESSER BAR	
50	014760622	2	アナトメネジ5.95	SET SCREW, SOCKET (CP) M5.95	
51	S12943001	1	プーラアツチヨウセツネジ	ADJUST SCREW	
52	S28263001	1	プーラオサエバネ	PULLER SPRING	
53	S28264001	1	プーラオサエボウダキ	PULLER PRESSER BAR CLAMP	
54	014770622	1	アナトメネジ6.35クボミ	SET SCREW, SOCKET (CP) M6.35	
55	062682012	1	ナベコ437-40X20	SCREW, PAN M4.37-40X20	
56	105234003	1	ナツト4.37	NUT, M4.37	
57	110167001	1	コロ	ROLLER	
58	110168001	1	コロジク	ROLLER SHAFT	
59	S12946001	1	プーラアゲレバー	PULLER LIFTING LEVER	
60	109239001	1	ナミバネザガネ	WAVE SPRING WASHER	
61	S28333001	1	ダンネジ5.95	STUD SCREW, M5.95	
62	159093009	1	ハンドル	HANDLE	
63	112700001	1	シメネジ5.95	SCREW, M5.95	
64	106588003	1	ナツト5.95	NUT, M5.95	
65	047400842	1	スプリングピンAW4X8	PIN, SPRING ROLL AW4x8	
66	S28265001	1	アンナイジク	GUIDE SHAFT	
67	014680422	1	アナトメネジ4.37クボミ	SET SCREW, SOCKET (CP) M4.37	
68	S28266001	1	アンナイイタ	GUIDE PLATE	
69	017681012	2	ボルト4.37X10	BOLT, M4.37X10	
70	S28267001	1	プーラアゲテコ	PULLER LIFTING LEVER	
71	S28268001	1	ダンネジ7.94	STUD SCREW, M7.94	
72	S28332001	1	プーラアゲイタ	PULLER LIFTER PLATE	
73	151987001	2	ダンネジ4.37	SHOULDER SCREW, M4.37	
74	103810002	1	ナミガタバネザガネ	WAVE SPRING WASHER	
75	S28269001	1	プーラレンケツイタ	PULLER CONNECTING PLATE	
76	103810002	2	ナミガタバネザガネ	WAVE SPRING WASHER	
77	159238001	1	ダンネジ4.37	STUD SCREW 4.37	
78	154149001	1	カンケツオサエダンネジ	STUD SCREW	
79	105234003	2	ナツト4.37	NUT, M4.37	
80	S28270001	1	チヨウセツイタ	CONTROL PLATE	
81	148847001	2	ザガネ	WASHER	
82	017681012	2	ボルト4.37X10	BOLT, M4.37X10	
84	107407003	2	シメネジ4.37	SCREW, M4.37	
90	S28273001	1	シタローラドダイ	LOWER ROLLER BASE	
91	018061022	2	アナボルト6X10	BOLT, SOCKET M6X10	
92	117608001	2	ミゾツキピン	DOWEL PIN	
93	S28274001	1	シタローラジク	LOWER ROLLER SHAFT	
94	014680422	2	アナトメネジ4.37クボミ	SET SCREW, SOCKET (CP) M4.37	
95	S28275001	1	シタローラカバー	LOWER ROLLER COVER	
96	S01696001	2	サラネジ3.57X6	SCREW, FLAT M3.57X6	
101	102538002	3	サラネジ3.57	SCREW, FLAT M3.57	
83-1	S28271001	1	<056,0X6> ゴムガイドA	RUBBER GUIDE (A)	
83-2	S28272001	1	<061,0V1,0W1> ゴムガイドB	RUBBER GUIDE (B)	
100-1	S28276000	1	<0V1,0W1> ゴムローラU	RUBBER ROLLER (U)	
102-1	S28279000	1	ゴムローラDクミ <056,0X6>	RUBBER ROLLER (D) ASSY	
100-2	S28277000	1	プラスチックギヤU26	PLASTIC GEAR (U26)	
102-2	S28282000	1	プラスチックギヤD13 <061>	PLASTIC GEAR (D13)	
100-3	S28278000	1	プラスチックギヤU30	PLASTIC GEAR (U30)	
102-3	S28283000	1	プラスチックギヤD15	PLASTIC GEAR (D15)	

N1. トリミングメス関係 / Trimming knife mechanism / Fadenabschneidemesseinheit /
 Mécanisme de couteau rafraîchisseur / Mecanismo de cuchilla cortahilos

<右メス装置 / RIGHT KNIFE DEVICE>

0W1

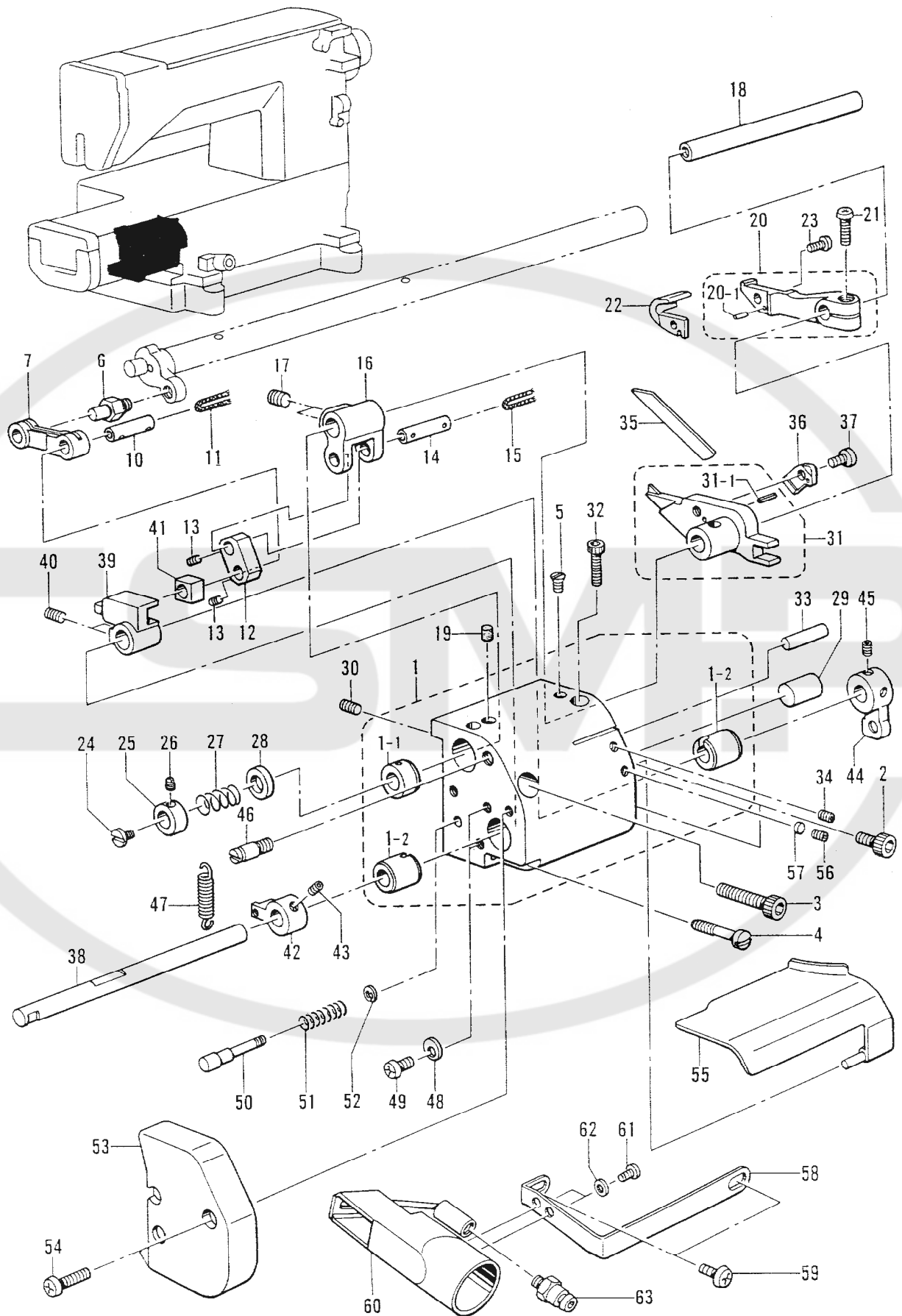

N1. トリミングメス関係 / Trimming knife mechanism / Fadenabschneidemeßereinheit /
Mécanisme de couteau rafraîchisseur / Mecanismo de cuchilla cortahilos

REF.NO.	CODE	Q'TY	ヒンメイ	NAME OF PARTS	RM
			<0W1>		
1	S28287001	1	ミギメスドダイクミ	RIGHT KNIFE BRACKET ASSY	
1-1	S28289000	1	ウワメスジクメタル	UPPER KNIFE SHAFT BUSH	
1-2	S28290000	2	レバージクメタル	LEVER SHAFT BUSH	
2	018501022	2	アナボルト5X10	BOLT, SOCKET M5X10	
3	018502522	1	アナボルト5X25	BOLT, SOCKET M5X25	
4	102023005	1	シメネジ4.37	SCREW, M4.37	
5	108960002	1	サラネジ3.57	SCREW, FLAT M3.57	
6	S28292001	1	メスクドウピン	KNIFE DRIVING PIN	
7	S28293000	1	ウワメスリンクL	UPPER KNIFE LINK (L)	
10	S28295001	1	リンクピンS	LINK PIN (S)	
11	140430001	1	クミヒモ (L=40)	WICK (L=40)	
12	S28297001	1	ウワメスリンクS	UPPER KNIFE LINK (S)	
13	014680422	2	アナトメネジ4.37クボミ	SET SCREW, SOCKET (CP) M4.37	
14	S28298001	1	リンクピンL	LINK PIN (L)	
15	S23323001	1	クミヒモ (L=52)	WICK (L=52)	
16	S28299000	1	メスクドウウデ	KNIFE DRIVING ARM	
17	152718001	2	アナトメネジ5.95	SET SCREW, SOCKET M5.95	
18	S28300001	1	ウワメスジク	UPPER KNIFE SHAFT	
19	S09043000	1	フェルト	FELT	
20	S28302001	1	ウワメスホルダクミ	UPPER KNIFE HOLDER ASSY	
20-1	149604001	1	ピン1.5X5.8	PIN, 1.5X5.8	
21	062681212	1	ナベコ437-40X12	SCREW, PAN M4.37-40X12	
22	S28305001	1	ウワメス	UPPER KNIFE	
23	062300612	1	ナベコ3X6	SCREW, PAN M3X6	
24	148834001	1	シメネジ3.57	SCREW, M3.57	
25	110243001	1	ヌノオサエカラー	COLLAR	
26	102716004	1	トメネジ4.37	SET SCREW, M4.37	
27	S28306001	1	メスアツバネ	SPRING	
28	S12696001	1	コロ	ROLLER	
29	S28307001	1	アンナイジク	GUIDE SHAFT	
30	014710522	1	アナトメネジ4.76クボミ	SET SCREW, SOCKET (CP) M4.76	
31	S28308001	1	シタメスホルダクミ	LOWER KNIFE HOLDER ASSY	
31-1	047140850	1	スプリングピン1.4X8	PIN, SPRING ROLL 1.4X8	
32	018401422	1	アナボルト4X14	BOLT, SOCKET M4X14	
33	153353001	1	コロF5X19.8	ROLLER (F), M5X19.8	
34	014680422	1	アナトメネジ4.37クボミ	SET SCREW, SOCKET (CP) M4.37	
35	S28310001	1	シタメス	LOWER KNIFE	
36	S28311001	1	シタメスオサエ	LOWER KNIFE PRESSER	
37	153208002	1	シメネジ4.37	SCREW, M4.37	
38	S28312001	1	ドロツブレバージク	DROP LEVER SHAFT	
39	S28313001	1	ドロツブレバー	DROP LEVER	
40	014680422	2	アナトメネジ4.37クボミ	SET SCREW, SOCKET (CP) M4.37	
41	S28314000	1	カクゴマ	SLIDE BLOCK	
42	S28315001	1	ドロツブウデ	DROP ARM	
43	014680422	2	アナトメネジ4.37クボミ	SET SCREW, SOCKET (CP) M4.37	
44	S28316001	1	ドロツブテコ	DROP LEVER	
45	014680422	2	アナトメネジ4.37クボミ	SET SCREW, SOCKET (CP) M4.37	
46	148144001	1	バネカケ	SPRING HOOK	
47	S28317001	1	ドロツブレバーバネ	DROP LEVER SPRING	
48	S28318001	2	ストツバ	STOPPER	
49	062680712	2	ナベコ437-40X7	SCREW, PAN M4.37-40X7	
50	S28319001	1	ストツバジク	STOPPER SHAFT	
51	S28320001	1	ストツバモシバネ	STOPPER SPRING	
52	048030342	1	トメワE3	RETAINING RING, E3	
53	S28321001	1	ミギメスドダイカバー	RIGHT KNIFE BRACKET COVER	
54	062681612	2	ナベコ437-40X16	SCREW, PAN M4.37-40X16	
55	S28322001	1	ヌノガイド	CLOTH GUIDE	
56	014680422	1	アナトメネジ4.37クボミ	SET SCREW, SOCKET (CP) M4.37	
57	S11624000	1	トメネジアテ	SET SCREW PLATE	
58	S28323001	1	キユウニユウカンササエ	CHAIN SUCTION PIPE SUPPORT	
59	062710712	2	ナベコ476-32X7	SCREW, PAN M4.76-32X7	
60	S28324001	1	キユウニユウカンクミ	CHAIN SUCTION PIPE ASSY	
61	062670512	2	ナベコ357-40X5	SCREW, PAN M3.57-40X5	
62	105248003	2	ザガネ	WASHER	
63	S28742000	1	ハーフユニオン	HALF UNION	

N2. トリミングメス関係 / Trimming knife mechanism / Fadenabschneidemesseinheit /
 Mécanisme de couteau rafraîchisseur / Mecanismo de cuchilla cortahilos

<左メス装置 / LEFT KNIFE DEVICE>

OX1
 OX6

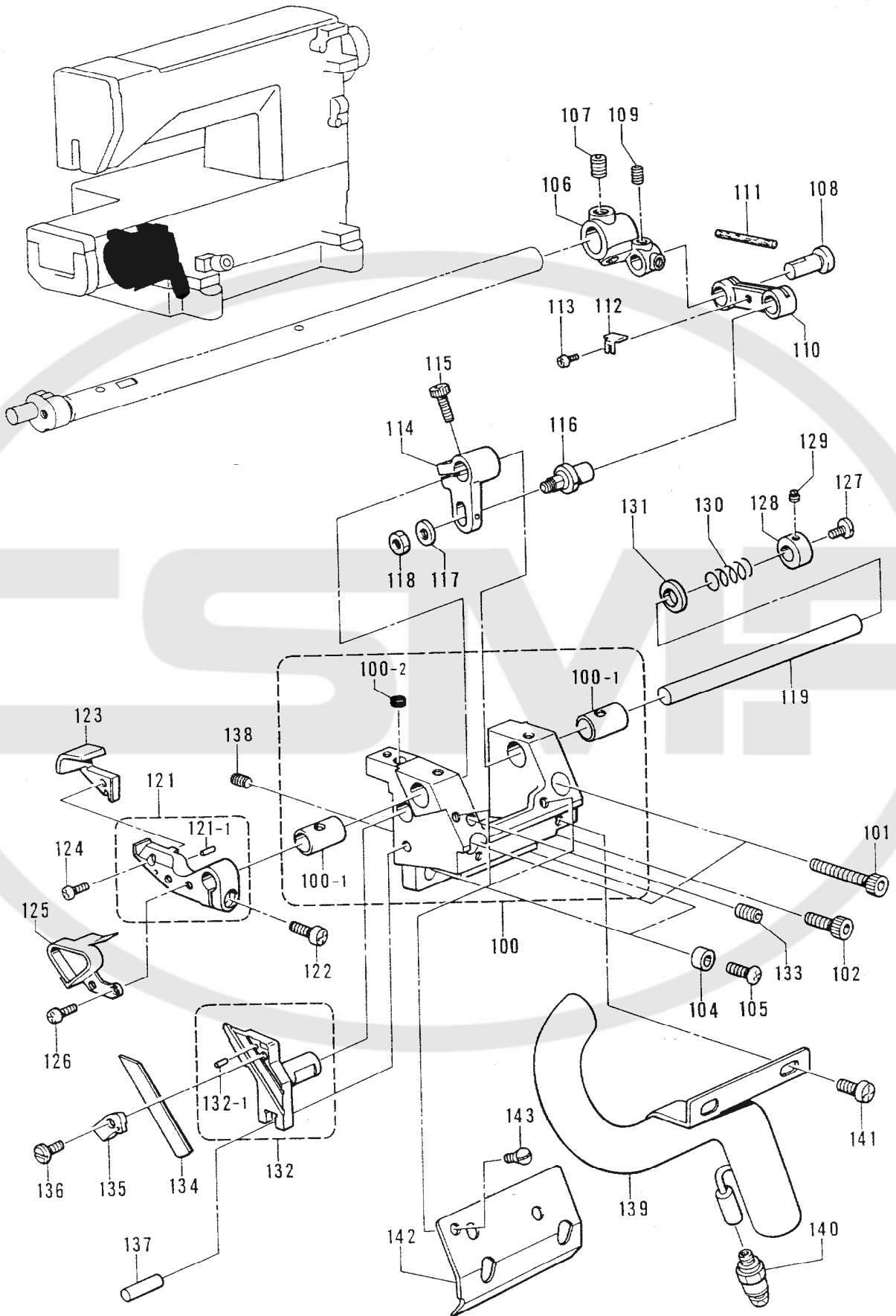

N2. トリミングメス関係 / Trimming knife mechanism / Fadenabschneidemesseinheit /
Mécanisme de couteau rafraîchisseur / Mecanismo de cuchilla cortahilos

REF.NO.	CODE	Q'TY	品名	NAME OF PARTS	R/M
			<0X1,0X6>		
100	S28336001	1	ヒダリメスドダイクミ	LEFT KNIFE BRACKET ASSY	
100-1	S28338000	2	ウワメスジクメタル	UPPER KNIFE SHAFT BUSH	
100-2	S28820000	1	ホジヨイタアテゴム	SUPPORT PLATE RUBBER	
101	018503022	2	アナボルト5X30	BOLT, SOCKET M5X30	
102	018501422	1	アナボルト5X14	BOLT, SOCKET M5X14	
104	S09124001	2	ハリイタササエイタカラー	COLLER	
105	S13385001	2	シメネジ3.57X10	SCREW, M3.57X10	
106	S28340001	1	メスクドウウデ	KNIFE DRIVING ARM	
107	152718001	2	アナトメネジ5.95	SET SCREW, SOCKET M5.95	
108	S28353001	1	ウワメスリンクジク	UPPER KNIFE LINK SHAFT	
109	014680422	2	アナトメネジ4.37クボミ	SET SCREW, SOCKET (CP) M4.37	
110	S28341000	1	ウワメスリンク	UPPER KNIFE LINK	
111	S28342000	1	フェルト	FELT	
112	S28231000	1	フェルトオサエ	FELT SUPPORT	
113	060630412	1	バインド238-56X4	SCREW, BIND M2.38-56X4	
114	S28343001	1	メスクドウレバー	KNIFE DRIVING LEVER	
115	018681022	1	アナボルト4.37X10	BOLT, SOCKET M4.37X10	
116	S13809001	1	スプレダロツドピン	PIN	
117	148847001	1	ザガネ	WASHER	
118	110161006	1	ナツト4.76	NUT, M4.76	
119	S28344001	1	ウワメスジク	UPPER KNIFE SHAFT	
121	S28346001	1	ウワメスホルダクミ	UPPER KNIFE HOLDER ASSY	
121-1	149604001	1	ピン1.5X5.8	PIN, 1.5X5.8	
122	062681212	1	ナベコ437-40X12	SCREW, PAN M4.37-40X12	
123	S28348001	1	ウワメス	UPPER KNIFE	
124	062300612	1	ナベコ3X6	SCREW, PAN M3X6	
125	S28349001	1	キリクスアンナイ	CHIP GUIDE	
126	062670612	2	ナベコ357-40X6	SCREW, PAN M3.57-40X6	
127	148834001	1	シメネジ3.57	SCREW, M3.57	
128	110243001	1	ヌノオサエカラー	COLLAR	
129	102716004	1	トメネジ4.37	SET SCREW, M4.37	
130	S28306001	1	メスアツバネ	SPRING	
131	S12696001	1	コロ	ROLLER	
132	S28350001	1	シタメスホルダクミ	LOWER KNIFE HOLDER ASSY	
132-1	047140850	1	スプリングピン1.4X8	PIN, SPRING ROLL 1.4X8	
133	014710522	1	アナトメネジ4.76クボミ	SET SCREW, SOCKET (CP) M4.76	
134	S28352001	1	シタメス	LOWER KNIFE	
135	S28311001	1	シタメスオサエ	LOWER KNIFE PRESSER	
136	153208002	1	シメネジ4.37	SCREW, M4.37	
137	153353001	1	コロF5X19.8	ROLLER (F), M5X19.8	
138	014680422	1	アナトメネジ4.37クボミ	SET SCREW, SOCKET (CP) M4.37	
139	S28354001	1	キュウニユウカクミ	CHAIN SUCTION PIPE ASSY	
140	S28742000	1	ハーフユニオン	HALF UNION	
141	060680712	2	バインド437-40X7	SCREW, BIND M4.37-40X7	
142	S28061001	1	ドダイカバー	BRACKET COVER	
143	S09121001	2	マルサラネジ3.57X6	SCREW, FLAT M3.57X6	

P. 縫製アタッチメント関係 / Sewing attachment mechanism / Zusatznähvorrichtung /
Dispositif de couture / Dispositivo de costura

0W1

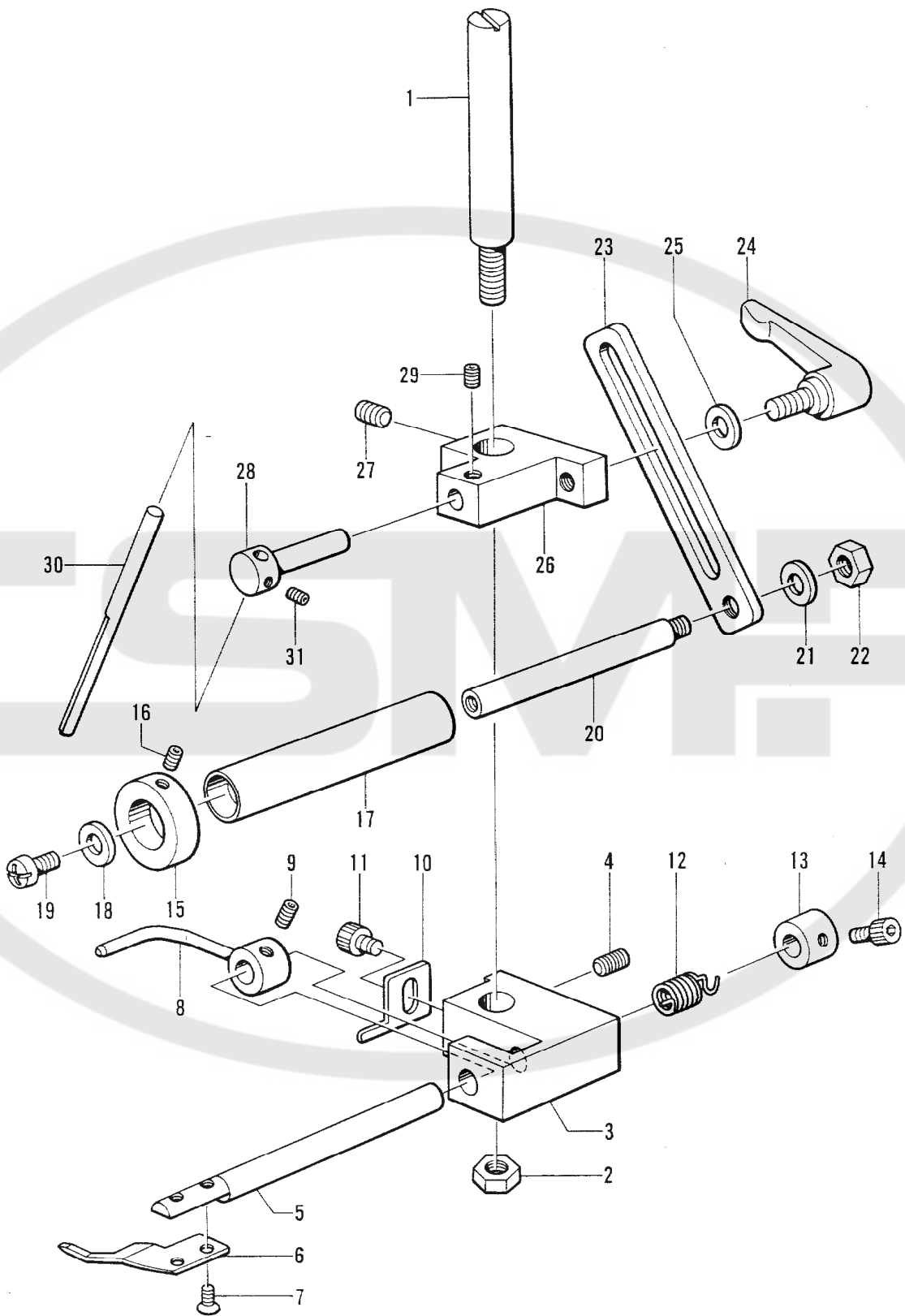

118-256,257-290

P. 縫製アタッチメント関係 / Sewing attachment mechanism / Zusatznähvorrichtung /
Dispositif de couture / Dispositivo de costura

REF.NO.	CODE	Q'TY	ヒンメイ	NAME OF PARTS	RM
			<0W1>		
1	S28629001	1	ドダイササエ	BASE SUPPORT	
2	021710202	1	ナツト2シユ4.76	NUT, 2 M4.76	
3	S28630001	1	ヌノオサエドダイ	CLOTH PRESSER BASE	
4	014760622	1	アナトメネジ5.95	SET SCREW, SOCKET (CP) M5.95	
5	S28631001	1	ヌノオサエジク	CLOTH PRESSER SHAFT	
6	S28632001	1	ヌノオサエ	CLOTH PRESSER	
7	141542001	2	サラネジ3.18	SCREW, FLAT M3.18	
8	S28633001	1	ヌノオサエレバー	CLOTH PRESSER LEVER	
9	014680422	1	アナトメネジ4.37クボミ	SET SCREW, SOCKET (CP) M4.37	
10	S28634001	1	レバーストツパ	LEVER STOPPER	
11	018680522	1	アナボルト4.37X5	BOLT, SOCKET M4.37X5	
12	S28635001	1	バネ	SPRING	
13	147402001	1	セットカラー	SET COLLAR	
14	018680522	1	アナボルト4.37X5	BOLT, SOCKET M4.37X5	
15	S28636001	1	セットカラー	SET COLLAR	
16	014680422	1	アナトメネジ4.37クボミ	SET SCREW, SOCKET (CP) M4.37	
17	S28637000	1	ローラF	ROLLER (F)	
18	025350332	1	ヒラザガネダイ3.5	WASHER, PLAIN L 3.5	
19	062670612	1	ナベコ357-40X6	SCREW, PAN M3.57-40X6	
20	S28638001	1	ローラFジク	ROLLER (F) SHAFT	
21	025710232	1	ヒラザガネチユウ4.76	WASHER, PLAIN M 4.76	
22	021710202	1	ナツト2シユ4.76	NUT, 2 M4.76	
23	S28639001	1	ローラFササエイタ	ROLLER (F) SUPPORT PLATE	
24	S28640000	1	クランプレバー	CLAMP LEVER	
25	025710232	1	ヒラザガネチユウ4.76	WASHER, PLAIN M 4.76	
26	S28641001	1	ゴムガイドドダイ	RUBBER GUIDE BASE	
27	014760622	1	アナトメネジ5.95	SET SCREW, SOCKET (CP) M5.95	
28	S28642001	1	ゴムガイドホルダ	RUBBER GUIDE HOLDER	
29	014680422	1	アナトメネジ4.37クボミ	SET SCREW, SOCKET (CP) M4.37	
30	S28643001	1	ゴムガイド	RUBBER GUIDE	
31	146427001	1	アナトメネジ3.18クボミ	SET SCREW, SOCKET (CP) M3.18	

Q. 針位置検出器関係 / Synchronizer / Synchronisator / Synchronisateur / Sincronizador

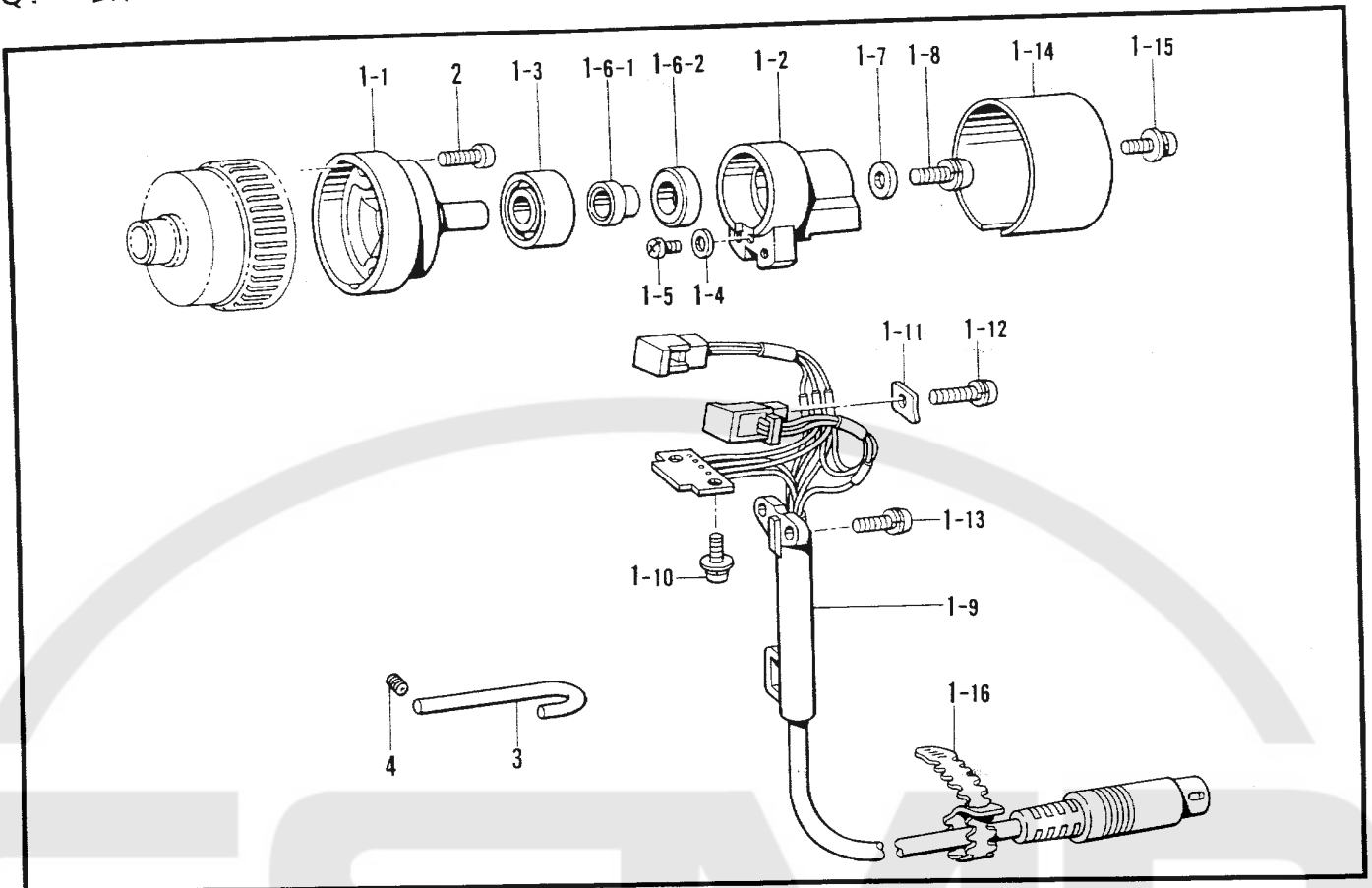

118-256,257-501

R. 糸払い関係 / Thread wiper mechanism / Fadenwischvorrichtung / Mécanisme de tire-fil / Mecanismo del limpiador de hilo

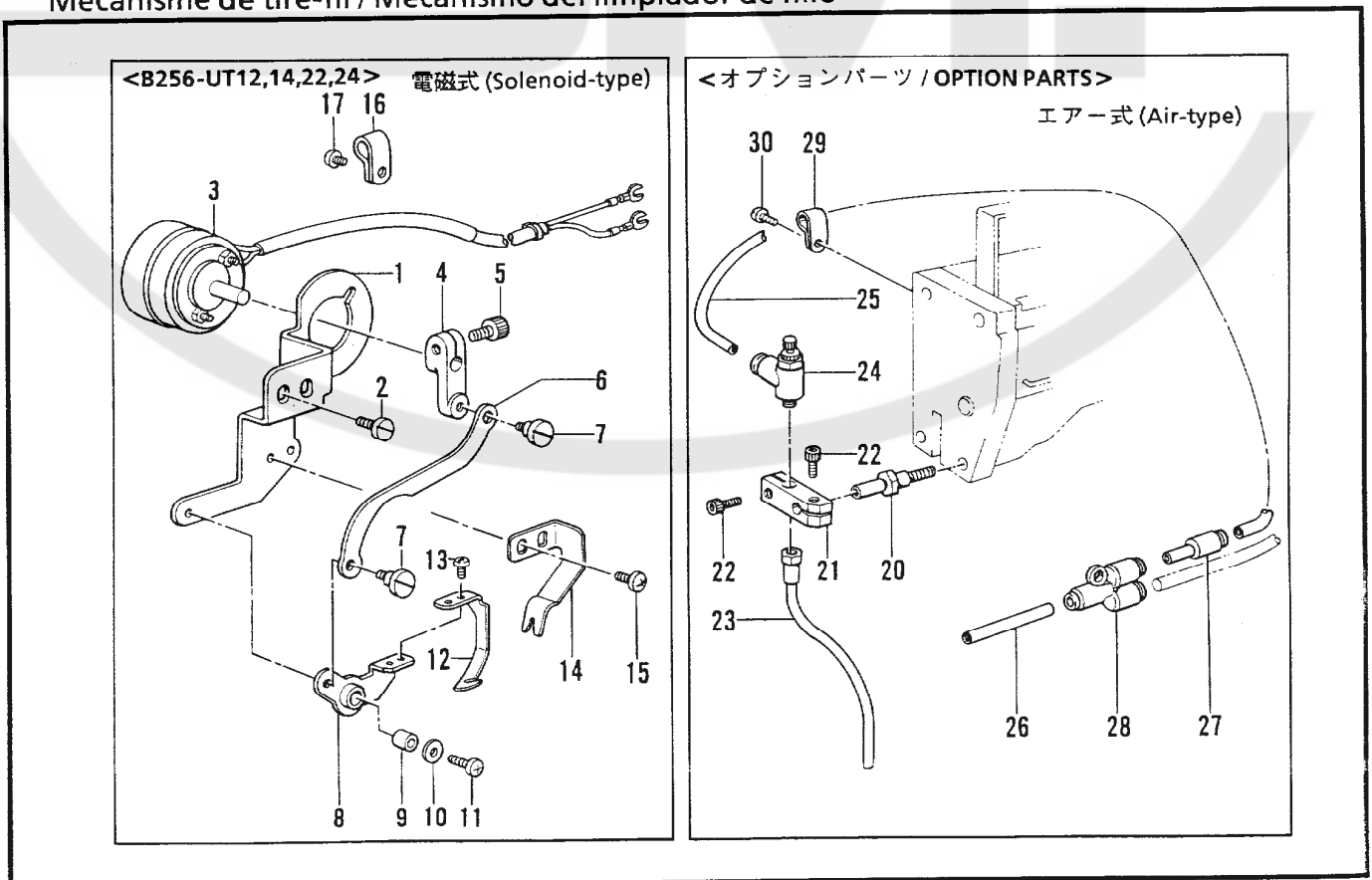

118-256-405

Q. 針位置検出器関係 / Synchronizer / Synchronisator / Synchronisateur / Sincronizador

REF.NO.	CODE	Q'TY	ヒンメイ	NAME OF PARTS	RM
1	J00102001	1	シンクロナイザクミ#15G7	SYNCHRONIZER ASSY #15G7	
1-1	234141001	1	ジシャク.ジククミ#4-1	MAGNET STUD ASSY #4-1	
1-2	234143001	1	ケンシユツキホルダー#4	SYNCHRONIZER HOLDER #4	
1-3	076000600	1	タマジクウケ6000VV	BALL BEARING 6000VV	
1-4	025030335	1	ヒラザガネダイ3	WASHER, PLAIN L3	
1-5	215083001	1	+ナベセット3X6D	SCREW, PAN (S WASHER) M3X6D	
1-6	234144001	1	ジシャク18.7クミ	MAGNET 18.7 ASSY	
1-6-1	234145001	1	ジシャクトリツケダイ#2	MAGNET SET BRACKET #2	
1-6-2	219558000	1	ジシャク12X18.7X6	MAGNET (12X18.7X6)	
1-7	234146001	1	ワ2X5.1X12ST	WASHER (2X5.1X12ST)	
1-8	211528001	1	+ナベセットネジ5X12	SCREW, PAN (S WASHER) M5X12	
1-9	J00103001	1	ソシコードクミG15-2	ELEMENT CORD ASSY G15-2	
1-10	230100001	2	+ナベセット3X6DB	SCREW, PAN (S WASHER) M3X6DB	
1-11	234153001	2	オサエカナグ	PRESSER PLATE	
1-12	216870001	2	+ナベセット4X16D	SCREW, PAN (S WASHER) M4X16D	
1-13	215082001	2	+ナベセット4X12DA	SCREW, PAN (S WASHER) M4X12DA	
1-14	234154002	1	シンクロナイザカバー#5	SYNCHRONIZER COVER #5	
1-15	216410003	2	+ナベセット4X10DB	SCREW, PAN (S WASHER) M4X10DB	
1-16	226391001	1	コードバンド	CORD BAND	
2	062711212	2	ナベコ476-32X12	SCREW, PAN M4.76-32X12	
3	S21941001	1	シンクロナイザガイド	SYNCHRONIZER GUIDE	
4	014680622	1	アナトメネジ4.37クボミ	SET SCREW, SOCKET (CP) M4.37	

118-256,257-501

R. 糸払い関係 / Thread wiper mechanism / Fadenwischvorrichtung / Mécanisme de tire-fil / Mecanismo del limpiador de hilo

REF.NO.	CODE	Q'TY	ヒンメイ	NAME OF PARTS	RM
<B256-UT12,14,22,24>					
1	S21867001	1	イトハライドダイ	THREAD WIPER BRACKET	
2	100644005	2	シメネジ4.37	SCREW, M4.37	
3	S21868101	1	イトハライソレノイドクミ	THREAD WIPER SOLENOID ASSY	
4	S21871101	1	イトハライレバー	THREAD WIPER LEVER	
5	018681022	1	アナボルト4.37X10	BOLT, SOCKET M4.37X10	
6	S21872101	1	イトハライロッド	THREAD WIPER ROD	
7	105237002	2	ダンネジ3.57	STUD SCREW 3.57	
8	S21873001	1	イトハライクランク	THREAD WIPER CRANK	
9	S21874000	1	シテンジク	FULCRUM SHAFT	
10	S21875001	1	ザガネ	WASHER	
11	062670812	1	ナベコ3.57-40X8	SCREW, PAN M3.57-40X8	
12	S21876001	1	イトハラ	THREAD WIPER	
13	062630412	2	ナベコ238-56X4	SCREW, PAN M2.38-56X4	
14	S21877001	1	イトツカミバネ	THREAD CLAMP SPRING	
15	060670512	2	バインド357-40X5	SCREW, BIND M3.57-40X5	
16	149547000	5	コードオサエ	CORD HOLDER (4N)	
17	062680712	5	ナベコ437-40X7	SCREW, PAN M4.37-40X7	
<オプションパーツ/OPTION PARTS>					
20	S28897001	1	ワイバードダイジク	WIPER BRACKET SHAFT	
21	S28898001	1	ワイバードダイ	WIPER BRACKET	
22	018681022	2	アナボルト4.37X10	BOLT, SOCKET M4.37X10	
23	S28899001	1	ワイバークミ	WIPER ASSY	
24	S23660000	1	スピードコントローラ	SPEED CONTROLLER	
25	S14085011	1	エアチューブ (L=1410)	AIR TUBE (L=1410)	
26	S28744000	1	エアチューブ (L=40)	AIR TUBE (L=40)	
27	S28902000	1	レジュース04-06	REDUCER 04-06	
28	S24021000	1	ユニオンワイ6	UNION 6	
29	S10243000	5	ナイロンランプNK-3N	CORD HOLDER (NK-3N)	
30	062680712	5	ナベコ437-40X7	SCREW, PAN M4.37-40X7	
参照番号 / Ref. No.		R-1~17 (電磁式 / Solenoid-type)		R-20~30 (エア式 / Air-type)	
糸払いセット / Thread wiper set		183821-101		S28896-001	

118-256-405

S1. 下飾り糸切り関係 / Lower thread trimmer mechanism / Unterefadensabschneider / Mécanisme de coupe-fils inférieur / Dispositivo de cortahilos inferior

B256-UT11,12,13,14
B257-UT11,13,32,34

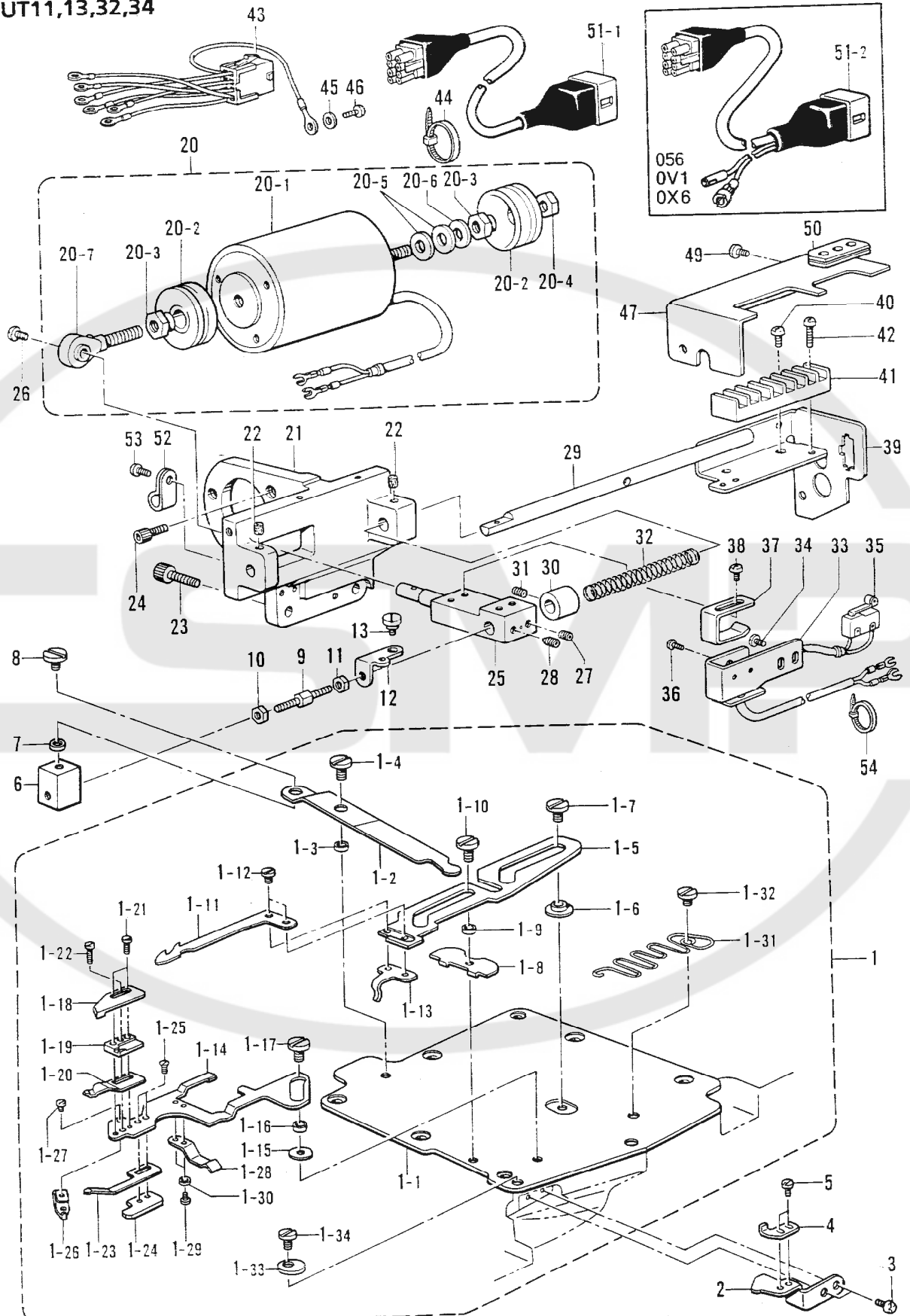

118-256,257-422

S1. 下飾り糸切り関係 / Lower thread trimmer mechanism / Unterefadensabschneider /
Mécanisme de coupe-fils inférieur / Dispositivo de cortahilos inferior

REF.NO.	CODE	Q'TY	品名	NAME OF PARTS	RM
			<B256-UT11,12,13,14> <B257-UT11,13,32,34>		
1	S28797101	1	シタカザリイトキリクミ	LOWER THREAD TRIMMER ASSY	
1-1	S28490001	1	ベッドウワカバーC	BED UPPER COVER (C)	
1-2	S28644001	1	シタメスクドレバー	LOWER KNIFE DRIVING LEVER	
1-3	S28645001	1	カラー	COLLAR	
1-4	S28646001	1	シメネジ3.57	SCREW, M3.57	
1-5	S28647001	1	シタメスドダイ	LOWER KNIFE BASE	
1-6	S28648001	1	ガイドチヨウセツタイ	GUIDE ADJUST PLATE	
1-7	S28646001	1	シメネジ3.57	SCREW, M3.57	
1-8	S28649000	1	ドダイスライドイタA	BASE SLIDE PLATE (A)	
1-9	S28645001	1	カラー	COLLAR	
1-10	S28646001	1	シメネジ3.57	SCREW, M3.57	
1-11	S28650101	1	シタメス	LOWER KNIFE	
1-12	106568003	2	シメネジ3.57	SCREW, M3.57	
1-13	S28651001	1	イトトリイタ	THREAD TAKE-UP PLATE	
1-14	S28652001	1	ウワメスドダイ	UPPER KNIFE BASE	
1-15	S28653000	1	ドダイスライドイタB	BASE SLIDE PLATE (B)	
1-16	S28645001	1	カラー	COLLAR	
1-17	S28646001	1	シメネジ3.57	SCREW, M3.57	
1-18	S28654001	1	ウワメス	UPPER KNIFE	
1-19	S28655001	1	シタメスガイド	LOWER KNIFE GUIDE	
1-20	S28656101	1	イトツカミバネ	THREAD CLAMP SPRING	
1-21	S28657001	2	シメネジ2.38X6.5	SCREW, M2.38X6.5	
1-22	S28658001	1	シメネジ2.38X9.5	SCREW, M2.38X9.5	
1-23	S28659101	1	イトツカミチヨウセツバネ	THREAD CLAMP ADJUST SPRING	
1-24	S28660001	1	バネトリツケイタ	SPRING SET PLATE	
1-25	S01694001	2	サラネジ2.38X4	SCREW, FLAT M2.38X4	
1-26	S28661001	1	イトツカミチヨウセツタイ	THREAD CLAMP ADJUST PLATE	
1-27	S01295001	1	シメネジ2.38X3.5	SCREW, M2.38X3.5	
1-28	S28662001	1	ウワメスドダイササエバネ	UPPER KNIFE BASE SUPPORT SPRING	
1-29	100105005	2	シメネジ2.38	SCREW, M2.38	
1-30	025630132	2	ヒラザガネシヨウ2.38	WASHER, PLAIN S 2.38	
1-31	S28663001	1	ウワメスドダイオシバネ	SPRING	
1-32	101671002	1	シメネジ4.37	SCREW, M4.37	
1-33	S28318001	1	ストツバ	STOPPER	
1-34	106629002	1	シメネジ4.37	SCREW, M4.37	
2	S28665001	1	ガイドイタA	GUIDE PLATE (A)	
3	060680712	2	バインド437-40X7	SCREW, BIND M4.37-40X7	
4	S28666001	1	ガイドイタB	GUIDE PLATE (B)	
5	062670412	2	ナベコ357-40X4	SCREW, PAN M3.57-40X4	
6	S28667001	1	クドウレンカンブロック	DRIVING CONNECTING BLOCK	
7	S28645001	1	カラー	COLLAR	
8	S28646001	1	シメネジ3.57	SCREW, M3.57	
9	S21906001	1	クドウレンカンジク	DRIVING CONNECTING SHAFT	
10	110140001	1	ナツト5.56	NUT, M5.56	
11	S21907001	1	ナツト5.56	NUT, M5.56	
12	S28668001	1	クドウレンカンイタ	DRIVING CONNECTING PLATE	
13	159908001	1	ダンネジ4.37	STUD SCREW, M4.37	
20	S21895001	1	イトキリソレノイドクミ	THREAD TRIMMER SOLENOID ASSY	
20-1	S21896001	1	イトキリソレノイド	THREAD TRIMMER SOLENOID	
20-2	S21897000	2	ゴムブーツ	RUBBER BOOT	
20-3	S21898001	2	ナツト8	NUT, M8	
20-4	021080302	1	ナツト3シユ8	NUT, 3 M8	
20-5	S21899000	2	ストツバゴム	RUBBER STOPPER	
20-6	025080232	1	ヒラザガネチユウ8	WASHER, PLAIN M 8	
20-7	S21900001	1	ロツドエンド	ROD END	
21	S21901001	1	イトキリソレノイドドダイ	THREAD TRIMMER SOLENOID BRACKET	
22	S09043000	2	フェルト	FELT	

S1. 下飾り糸切り関係 / Lower thread trimmer mechanism / Unterefadensabschneider /
 Mécanisme de coupe-fils inférieur / Dispositivo de cortahilos inferior

B256-UT11,12,13,14
 B257-UT11,13,32,34

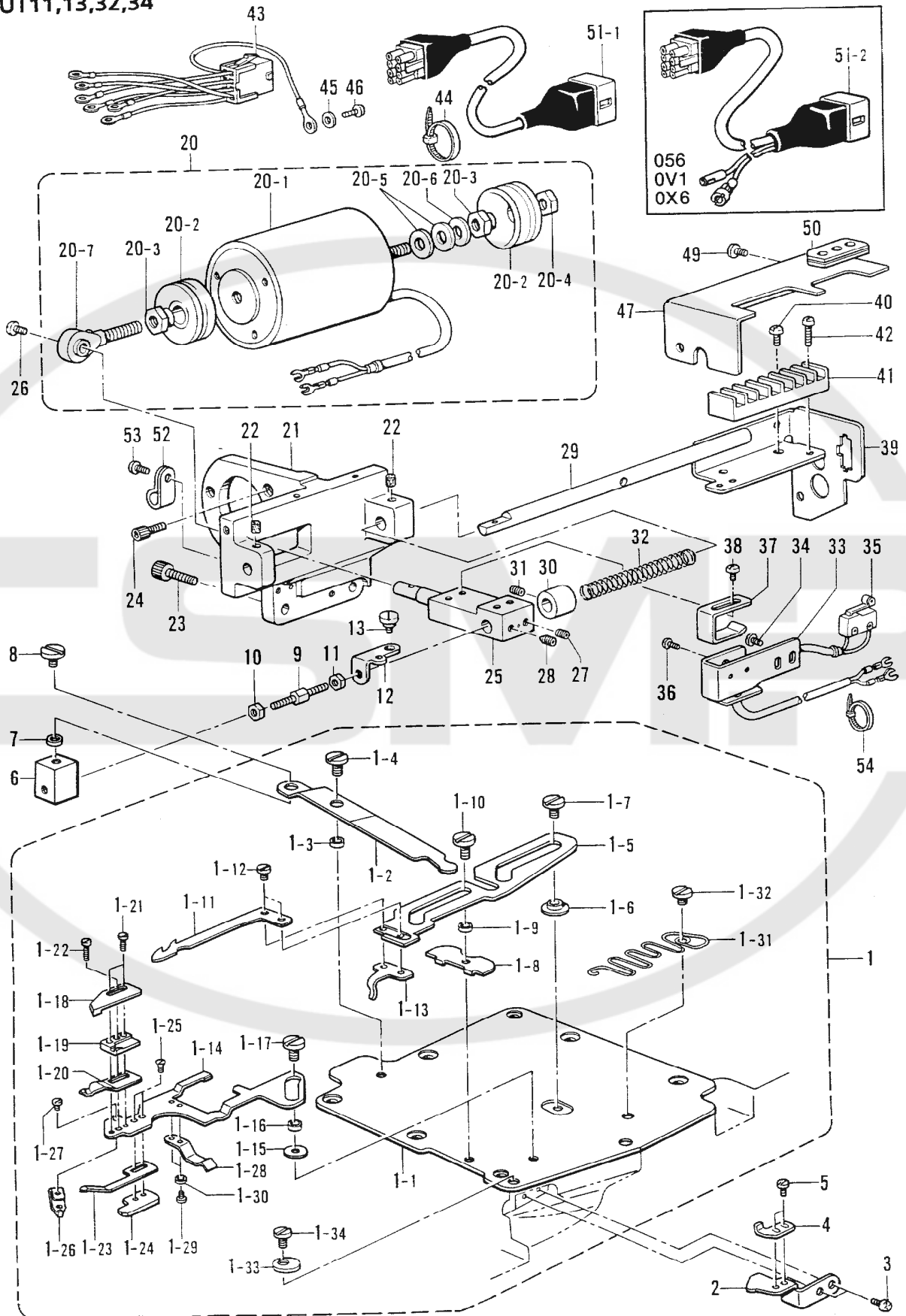

S1. 下飾り糸切り関係 / Lower thread trimmer mechanism / Unterefadensabschneider /
Mécanisme de coupe-fils inférieur / Dispositivo de cortahilos inferior

REF.NO.	CODE	Q'TY	ヒンメイ	NAME OF PARTS	RM
23	018062022	2	アナボルト6X20	BOLT, SOCKET M6X20	
24	018501222	3	アナボルト5X12	BOLT, SOCKET M5X12	
25	S21902001	1	イトキリクドウウデ	THREAD TRIMMER DRIVING ARM	
26	062680512	1	ナベコ437-40X5	SCREW, PAN M4.37-40X5	
27	014760622	1	アナトメネジ5.95	SET SCREW, SOCKET (CP) M5.95	
28	118853001	1	アナトメネジ5.95	SET SCREW, SOCKET M5.95	
29	S21903001	1	イトキリクドウジク	THREAD TRIMMER DRIVING SHAFT	
30	104521002	1	セツトカラー	SET COLLAR	
31	014770622	1	アナトメネジ6.35クボミ	SET SCREW, SOCKET (CP) M6.35	
32	S21904101	1	イトキリフツキバネ	CARRIAGE RETURN SPRING	
33	S21933001	1	スイッチダイ	SWITCH BASE	
34	060680712	2	バインド437-40X7	SCREW, BIND M4.37-40X7	
35	S21934001	1	スイッチクミ	SWITCH ASSY	
36	062020805	2	ナベコ2X8	SCREW, PAN M2X8	
37	S21935001	1	スイッチイタ	SWITCH PLATE	
38	060680712	2	バインド437-40X7	SCREW, BIND M4.37-40X7	
39	S28759001	1	コネクタターミナル	CONNECTOR TERMINAL	
40	060680712	4	バインド437-40X7	SCREW, BIND M4.37-40X7	
41	S21937001	1	タンシダイ	TERMINAL BLOCK	
42	062301616	2	ナベコM3X16	SCREW, PAN M3X16	
43	S21938001	1	コードクミ	CORD ASSY	
44	S04159000	1	バインド1M	BAND (1M)	
45	S02745001	1	ザガネ	WASHER	
46	062680663	1	ナベコ437-40X6	SCREW, PAN M4.37-40X6	
47	S28760001	1	コネクタカバー	CONNECTOR COVER	
49	060680512	3	バインド437-40X5	SCREW, BIND M4.37-40X5	
50	233193001	1	テモトコードブツシング	CORD BUSH	
51-1	S21940101	1	ケーブルクミ	CABLE ASSY	
52	S25907000	1	コードホルダ#9	CORD HOLDER (9N)	
53	062680712	1	ナベコ437-40X7	SCREW, PAN M4.37-40X7	
54	S04159000	1	バインド1M	BAND (1M)	
51-2	S28669001	1	<056,0V1,0X6> ケーブルクミ	CABLE ASSY	

S2. 下飾り糸切り関係 / Lower thread trimmer mechanism / Unterefadensabschneider /
 Mécanisme de coupe-fils inférieur / Dispositivo de cortahilos inferior

B256-UT21,22,23,24
 B257-UT21,23,42,44

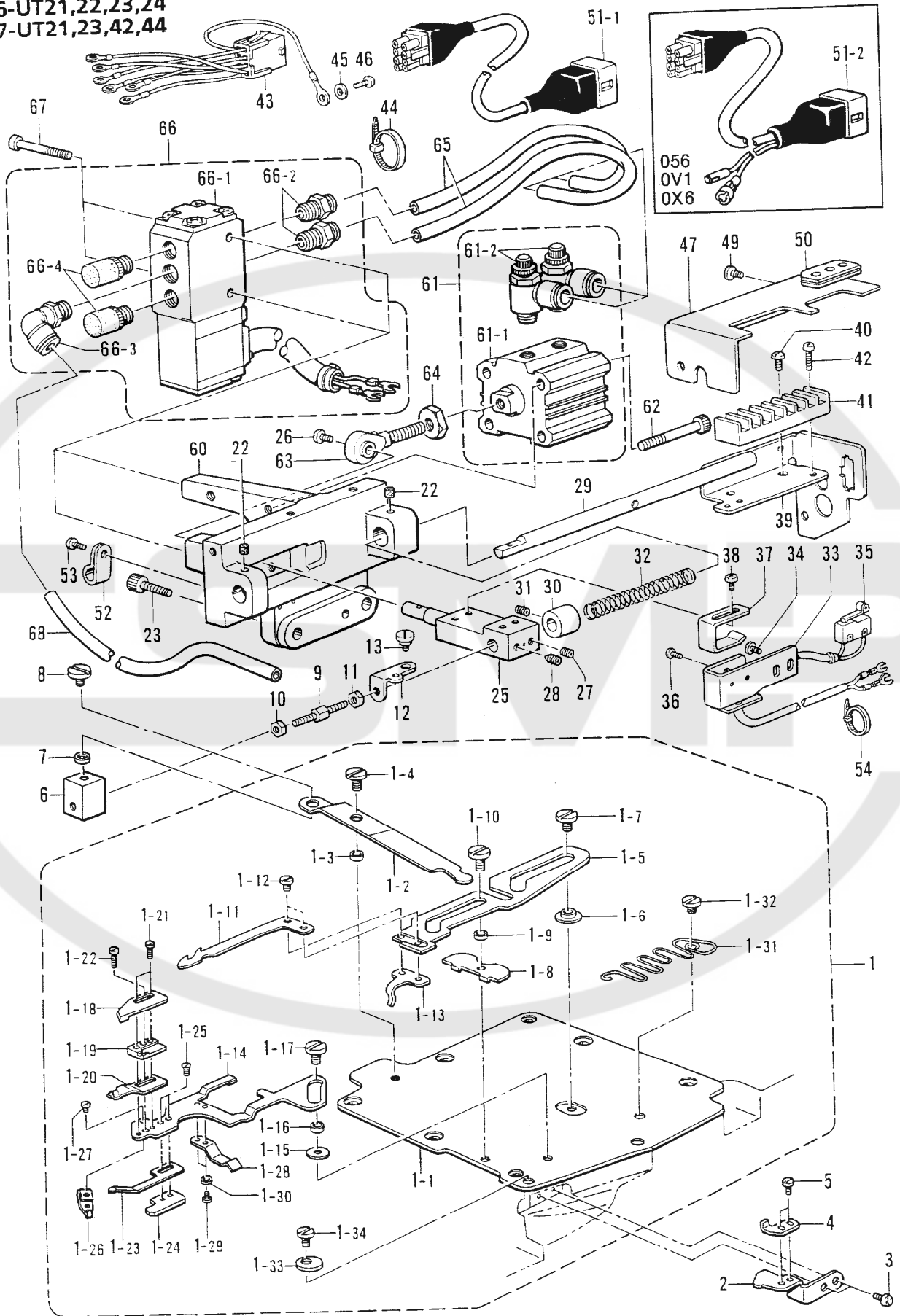

S2. 下飾り糸切り関係 / Lower thread trimmer mechanism / Unterefadensabschneider /
Mécanisme de coupe-fils inférieur / Dispositivo de cortahilos inferior

REF.NO.	CODE	Q'TY	ヒンメイ	NAME OF PARTS	RM
			<B256-UT21,22,23,24> <B257-UT21,23,42,44>		
1	S28797101	1	シタカザリイトキリクミ	LOWER THREAD TRIMMER ASSY	
1-1	S28490001	1	ベッドウワカバーC	BED UPPER COVER (C)	
1-2	S28644001	1	シタメスクドウレバー	LOWER KNIFE DRIVING LEVER	
1-3	S28645001	1	カラー	COLLAR	
1-4	S28646001	1	シメネジ3.57	SCREW, M3.57	
1-5	S28647001	1	シタメスドダイ	LOWER KNIFE BASE	
1-6	S28648001	1	ガイドチヨウセツタイ	GUIDE ADJUST PLATE	
1-7	S28646001	1	シメネジ3.57	SCREW, M3.57	
1-8	S28649000	1	ドダイスライドイタA	BASE SLIDE PLATE (A)	
1-9	S28645001	1	カラー	COLLAR	
1-10	S28646001	1	シメネジ3.57	SCREW, M3.57	
1-11	S28650101	1	シタメス	LOWER KNIFE	
1-12	106568003	2	シメネジ3.57	SCREW, M3.57	
1-13	S28651001	1	イトトリイタ	THREAD TAKE-UP PLATE	
1-14	S28652001	1	ウワメスドダイ	UPPER KNIFE BASE	
1-15	S28653000	1	ドダイスライドイタB	BASE SLIDE PLATE (B)	
1-16	S28645001	1	カラー	COLLAR	
1-17	S28646001	1	シメネジ3.57	SCREW, M3.57	
1-18	S28654001	1	ウワメス	UPPER KNIFE	
1-19	S28655001	1	シタメスガイド	LOWER KNIFE GUIDE	
1-20	S28656101	1	イトツカミバネ	THREAD CLAMP SPRING	
1-21	S28657001	2	シメネジ2.38X6.5	SCREW, M2.38X6.5	
1-22	S28658001	1	シメネジ2.38X9.5	SCREW, M2.38X9.5	
1-23	S28659101	1	イトツカミチヨウセツバネ	THREAD CLAMP ADJUST SPRING	
1-24	S28660001	1	バネトリツケイタ	SPRING SET PLATE	
1-25	S01694001	2	サラネジ2.38X4	SCREW, FLAT M2.38X4	
1-26	S28661001	1	イトツカミチヨウセツタイ	THREAD CLAMP ADJUST PLATE	
1-27	S01295001	1	シメネジ2.38X3.5	SCREW, M2.38X3.5	
1-28	S28662001	1	ウワメスドダイササエバネ	UPPER KNIFE BASE SUPPORT SPRING	
1-29	100105005	2	シメネジ2.38	SCREW, M2.38	
1-30	025630132	2	ヒラザガネシヨウ2.38	WASHER, PLAIN S 2.38	
1-31	S28663001	1	ウワメスドダイオシバネ	SPRING	
1-32	101671002	1	シメネジ4.37	SCREW, M4.37	
1-33	S28318001	1	ストツバ	STOPPER	
1-34	106629002	1	シメネジ4.37	SCREW, M4.37	
2	S28665001	1	ガイドイタA	GUIDE PLATE (A)	
3	060680712	2	バインド437-40X7	SCREW, BIND M4.37-40X7	
4	S28666001	1	ガイドイタB	GUIDE PLATE (B)	
5	062670412	2	ナベコ357-40X4	SCREW, PAN M3.57-40X4	
6	S28667001	1	クドウレンカンブロック	DRIVING CONNECTING BLOCK	
7	S28645001	1	カラー	COLLAR	
8	S28646001	1	シメネジ3.57	SCREW, M3.57	
9	S21906001	1	クドウレンカンジク	DRIVING CONNECTING SHAFT	
10	110140001	1	ナツト5.56	NUT, M5.56	
11	S21907001	1	ナツト5.56	NUT, M5.56	
12	S28668001	1	クドウレンカンイタ	DRIVING CONNECTING PLATE	
13	159908001	1	ダンネジ4.37	STUD SCREW, M4.37	
22	S09043000	2	フェルト	FELT	
23	018062022	2	アナボルト6X20	BOLT, SOCKET M6X20	
25	S21902001	1	イトキリクドウウデ	THREAD TRIMMER DRIVING ARM	
26	062680512	1	ナベコ437-40X5	SCREW, PAN M4.37-40X5	
27	014760622	1	アナトメネジ5.95	SET SCREW, SOCKET (CP) M5.95	
28	118853001	1	アナトメネジ5.95	SET SCREW, SOCKET M5.95	
29	S21903001	1	イトキリクドウジク	THREAD TRIMMER DRIVING SHAFT	
30	104521002	1	セツトカラー	SET COLLAR	
31	014770622	1	アナトメネジ6.35クボミ	SET SCREW, SOCKET (CP) M6.35	
32	S21904101	1	イトキリフツキバネ	CARRIAGE RETURN SPRING	

S2. 下飾り糸切り関係 / Lower thread trimmer mechanism / Unterefadensabschneider / Mécanisme de coupe-fils inférieur / Dispositivo de cortahilos inferior

B256-UT21,22,23,24
B257-UT21,23,42,44

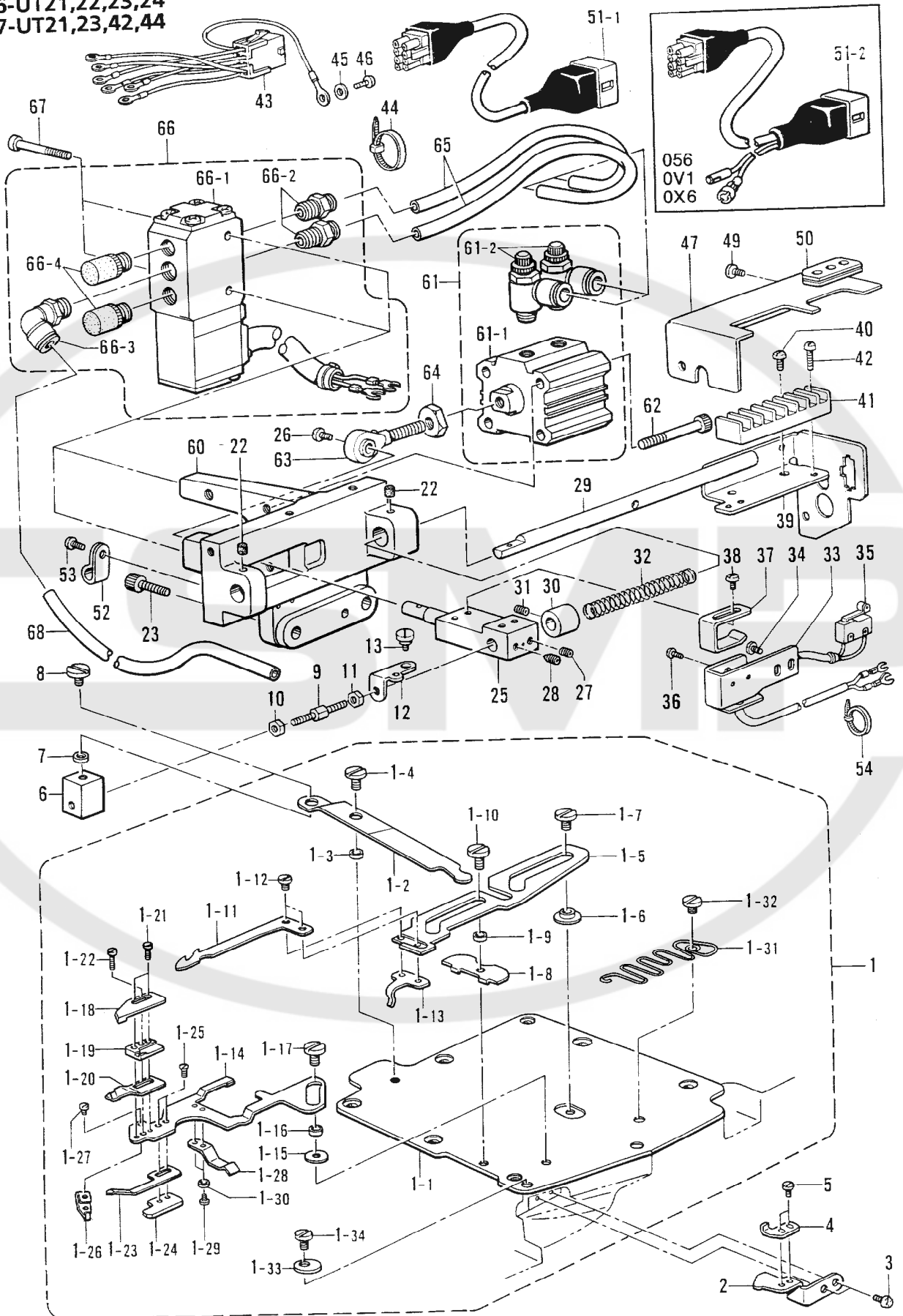

S2. 下飾り糸切り関係 / Lower thread trimmer mechanism / Unterefadensabschneider /
Mécanisme de coupe-fils inférieur / Dispositivo de cortahilos inferior

REF.NO.	CODE	Q'TY	ヒンメイ	NAME OF PARTS	RM
33	S21933001	1	スイッチダイ	SWITCH BASE	
34	060680712	2	バインド437-40X7	SCREW, BIND M4.37-40X7	
35	S21934001	1	スイッチクミ	SWITCH ASSY	
36	062020805	2	ナベコ2X8	SCREW, PAN M2X8	
37	S21935001	1	スイッチイタ	SWITCH PLATE	
38	060680712	2	バインド437-40X7	SCREW, BIND M4.37-40X7	
39	S28759001	1	コネクタターミナル	CONNECTOR TERMINAL	
40	060680712	4	バインド437-40X7	SCREW, BIND M4.37-40X7	
41	S21937001	1	タンシダイ	TERMINAL BLOCK	
42	062301616	2	ナベコM3X16	SCREW, PAN M3X16	
43	S21938001	1	コードクミ	CORD ASSY	
44	S04159000	1	バンド1M	BAND (1M)	
45	S02745001	1	ザガネ	WASHER	
46	062680663	1	ナベコ437-40X6	SCREW, PAN M4.37-40X6	
47	S28760001	1	コネクタカバー	CONNECTOR COVER	
49	060680512	3	バインド437-40X5	SCREW, BIND M4.37-40X5	
50	233193001	1	テモトコードブツシング	CORD BUSH	
51-1	S21940101	1	ケーブルクミ	CABLE ASSY	
52	S25907000	1	コードホルダ#9	CORD HOLDER (9N)	
53	062680712	1	ナベコ437-40X7	SCREW, PAN M4.37-40X7	
54	S04159000	1	バンド1M	BAND (1M)	
60	S28678001	1	イトケリシリンダードダイ	THREAD TRIMMER CYLINDER BRACKET	
61	S28670000	1	エアシリンダクミ	AIR CYLINDER ASSY	
61-1	S28671000	1	エアシリンダ	AIR CYLINDER	
61-2	S28599000	2	スピードコントローラ	SPEED CONTROLLER	
62	415006002	4	アナボルト5X40	BOLT, SOCKET M5X40	
63	S21900001	1	ロッドエンド	ROD END	
64	021080302	1	ナツト3シユ8	NUT, 3 M8	
65	S28674000	2	エアチューブ (L = 200)	AIR TUBE (L = 200)	
66	S28675000	1	ソレノイドバルブクミ	SOLENOID VALVE ASSY	
66-1	S28676000	1	ソレノイドバルブ	SOLENOID VALVE	
66-2	S01522000	2	ハーフユニオン	HALF UNION	
66-3	S01542000	1	エルボユニオン61	ELBOW UNION 61	
66-4	159874000	2	サイレンサー	SILENCER	
67	062303012	2	ナベコM3X30	SCREW, PAN M3X30	
68	S28677000	1	エアチューブ (L = 1000)	AIR TUBE (L = 1000)	
51-2	S28669001	1	<056,0V1,0X6> ケーブルクミ	CABLE ASSY	

T. 上飾り糸切り関係 / Upper thread trimmer mechanism / Oberfadenabschneider /
Mécanisme de coupe-fils supérieur / Dispositivo de cortahilos superior

B257-UT32,34,42,44

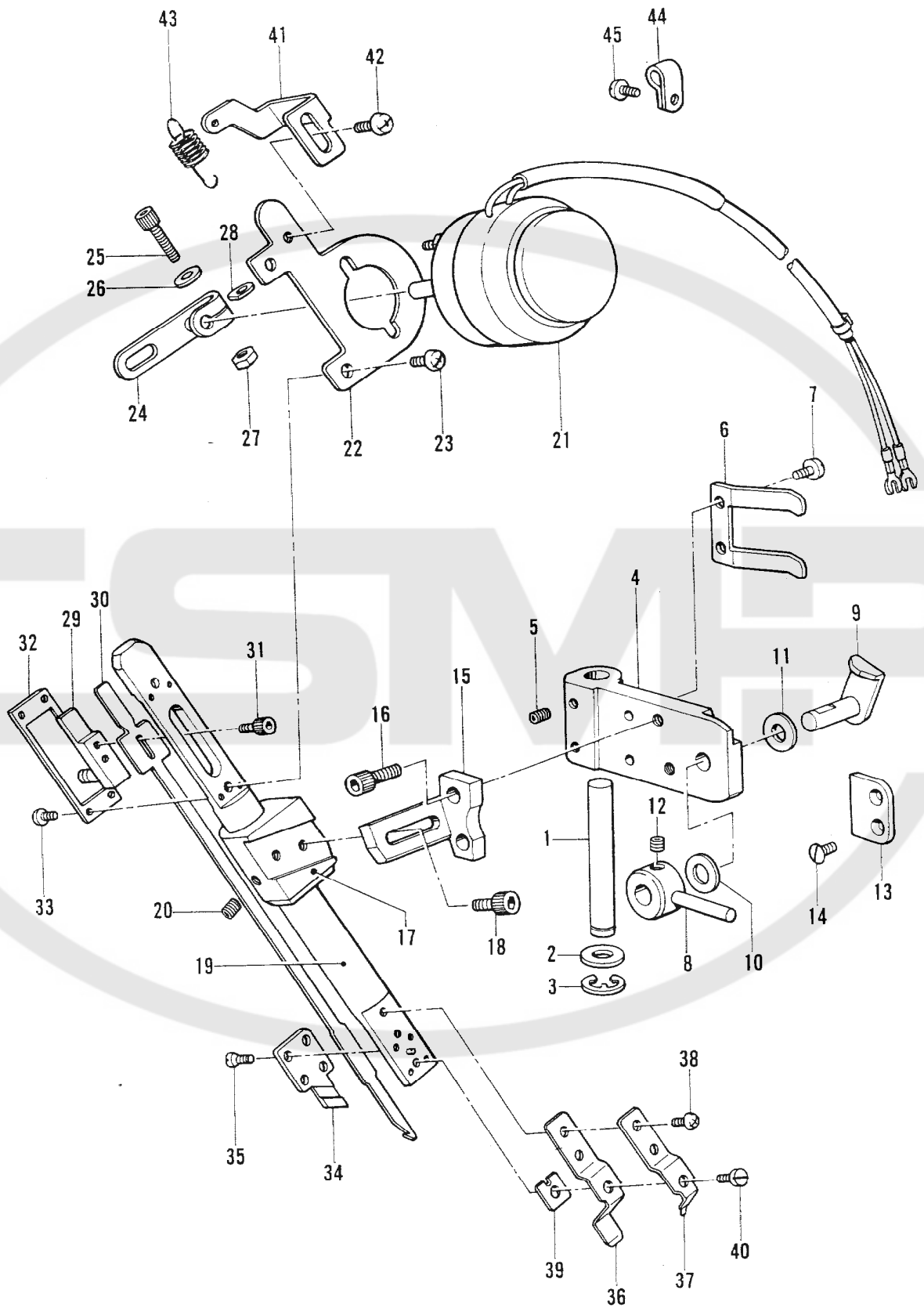

T. 上飾り糸切り関係 / Upper thread trimmer mechanism / Oberfadenabschneider /
Mécanisme de coupe-fils supérieur / Dispositivo de cortahilos superior

REF.NO.	CODE	Q'TY	ヒンメイ	NAME OF PARTS	RM
			<B257-UT32,34,42,44>		
1	S21964001	1	ドダイササエジク	SUPPORT SHAFT	
2	S07350001	1	ザガネ	WASHER	
3	048050342	1	トメワE5	RETAINING RING, E5	
4	S21965001	1	イトキリドダイ	THREAD TRIMMER BRACKET	
5	014680422	2	アナトメネジ4.37クボミ	SET SCREW, SOCKET (CP) M4.37	
6	S21966001	1	イトキリドダイバネ	SPRING	
7	062680512	2	ナベコ437-40X5	SCREW, PAN M4.37-40X5	
8	S21967001	1	イトキリドダイレバー	THREAD TRIMMER BRACKET LEVER	
9	S21968001	1	ドダイレバージク	LEVER SHAFT	
10	118735002	1	ザガネ	WASHER	
11	109763002	1	ザガネ	WASHER	
12	014680422	2	アナトメネジ4.37クボミ	SET SCREW, SOCKET (CP) M4.37	
13	S21969001	1	イトキリドダイストツバ	STOPPER	
14	S01696001	2	サラネジ3.57X6	SCREW, FLAT M3.57X6	
15	S21970001	1	イトキリトリツケタイ	SET PLATE	
16	018501022	2	アナボルト5X10	BOLT, SOCKET M5X10	
17	S21971001	1	メスガイドシジダイ	KNIFE GUIDE BASE	
18	018680822	2	アナボルト4.37X8	BOLT, SOCKET M4.37X8	
19	S21972001	1	メスガイドクミ	KNIFE GUIDE ASSY	
20	014680422	2	アナトメネジ4.37クボミ	SET SCREW, SOCKET (CP) M4.37	
21	S21974001	1	イトキリソレノイドクミ	THREAD TRIMMER SOLENOID ASSY	
22	S21976001	1	ソレノイドダイ	SOLENOID.BRACKET	
23	062680612	2	ナベコ4.37-40X6	SCREW, PAN M4.37-40X6	
24	S21977001	1	イトキリクドウウデ	THREAD TRIMMER DRIVING ARM	
25	018401422	1	アナボルト4X14	BOLT, SOCKET M4X14	
26	100645003	1	ザガネ	WASHER	
27	021400102	1	ナツト1シユ4	NUT, 1 M4	
28	S21978000	1	カンザ	SPACER	
29	S21979001	1	メスクドウコマ	KNIFE DRIVING BLOCK	
30	S21980001	1	イドウメス	MOVABLE KNIFE	
31	018300622	2	アナボルト3X6	BOLT, SOCKET M3X6	
32	S21981001	1	ガイドイタ	GUIDE PLATE	
33	062630412	4	ナベコ238-56X4	SCREW, PAN M2.38-56X4	
34	S21982101	1	コテイメス	FIXED KNIFE	
35	S21983001	4	サラネジ2.38X5.5	SCREW, FLAT M2.38X5.5	
36	S21984001	1	イトツカミバネ	THREAD HOLD SPRING	
37	S21985001	1	イトツカミチヨウセツバネ	THREAD CLAMP ADJUST SPRING	
38	062660512	2	ナベコネジ318-40X5	SCREW, PAN M3.18-40X5	
39	S21986001	1	スペーサ	SPACER	
40	102836004	1	シメネジ3.18	SCREW, M3.18	
41	S21987001	1	バネカケ	SPRING HOOK	
42	060680512	1	バインド437-40X5	SCREW, BIND M4.37-40X5	
43	S21988001	1	モドシバネ	RETURN SPRING	
44	149547000	5	コードオサエ#4	CORD HOLDER (4N)	
45	062680712	5	ナベコ437-40X7	SCREW, PAN M4.37-40X7	

U. 電磁押工上げ関係 / Presser foot lifting solenoid set /
 Solenoidsatz für die anhebung des stoffdrückerfußes /
 Conjunto aéreo del levantador del pie / Conjunto solenoide del levantador

B256-UT13,14
 B257-UT13,34

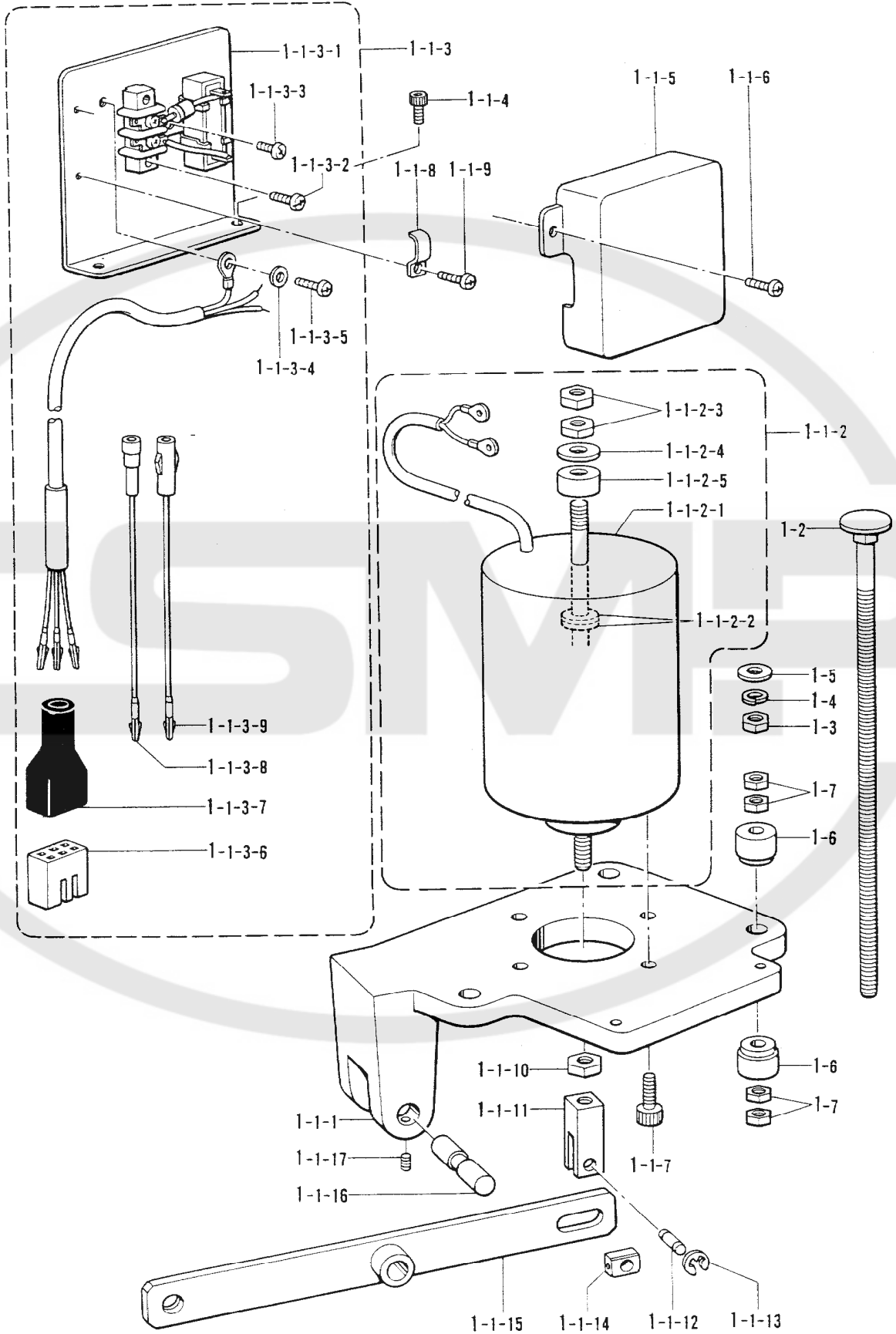

U. 電磁押工上ゲ関係 / Presser foot lifting solenoid set /
 Solenoidsatz für die anhebung des stoffdrückerfußes /
 Conjunto aéreo del levantador del pie / Conjunto solenoide del levantador

REF.NO.	CODE	Q'TY	ヒンメイ	NAME OF PARTS	RM
			<B256-UT13,14> <B257-UT13,34>		
1	183796201	1	デンジオサエアゲセットB	SOLENOID PRESSER FOOT LIFTING SET (B)	
1-1	S21946101	1	デンジオサエアゲクミ	SOLENOID PRESSER FOOT LIFTING ASSY	
1-1-1	S21947001	1	ソレノイドダイ	SOLENOID BRACKET	
1-1-2	S21948101	1	オサエアゲソレノイドクミ	PRESSER FOOT LIFTING SOLENOID ASSY	
1-1-2-1	S21949101	1	オサエアゲソレノイド	PRESSER FOOT LIFTING SOLENOID	
1-1-2-2	S21899000	2	ストツパゴム	RUBBER STOPPER	
1-1-2-3	021080302	2	ナツト3シユ8	NUT, 3 M8	
1-1-2-4	025080232	1	ヒラザガネチユウ8	WASHER, PLAIN M 8	
1-1-2-5	S28821000	1	カンシヨウゴム	CUSHION RUBBER	
1-1-3	S21950009	1	タンシダイベースクミ	TERMINAL BLOCK BASE ASSY	
1-1-3-1	S21951001	1	タンシダイベース	TERMINAL BLOCK BASE	
1-1-3-2	062671012	2	ナベコ357-40X10	SCREW, PAN M3.57-40X10	
1-1-3-3	062670612	1	ナベコ357-40X6	SCREW, PAN M3.57-40X6	
1-1-3-4	S02745001	1	ザガネ	WASHER	
1-1-3-5	062680663	1	ナベコ437-40X6	SCREW, PAN M4.37-40X6	
1-1-3-6	143522000	1	ナイロンコネクター	NYLON CONNECTOR	
1-1-3-7	220077001	1	プラグカバー#14	PLUG COVER (#14)	
1-1-3-8	S05981000	1	Bコード100クミ2	B-CORD 100 ASSY 2	
1-1-3-9	S05982000	1	Wコード100クミ	W-CORD 100 ASSY	
1-1-4	018400832	2	アナボルト4X8	BOLT, SOCKET M4X8	
1-1-5	S02592009	1	タンシダイカバー	TERMINAL BLOCK COVER	
1-1-6	062670612	2	ナベコ357-40X6	SCREW, PAN M3.57-40X6	
1-1-7	018061631	4	アナボルト6X16	BOLT, SOCKET M6X16	
1-1-8	142268001	1	コードオサエL	CORD HOLDER (L)	
1-1-9	062670612	1	ナベコ357-40X6	SCREW, PAN M3.57-40X6	
1-1-10	021080302	1	ナツト3シユ8	NUT, 3 M8	
1-1-11	S21953001	1	ソレノイドツギテ	SOLENOID JOINT	
1-1-12	S09637001	1	ピン	PIN	
1-1-13	048040342	2	トメワE4	RETAINING RING, E4	
1-1-14	102630001	1	ハリボウアンナイカクコマ	NEEDLE BAR GUIDE SLIDE BLOCK	
1-1-15	S21954001	1	オサエアゲレバー	PRESSER BAR LIFTER LEVER	
1-1-16	S21955001	1	オサエアゲレバーク	PRESSER BAR LIFTER LEVER SHAFT	
1-1-17	014710522	2	アナトメネジ4.76クボミ	SET SCREW, SOCKET (CP) M4.76	
1-2	S21952101	3	カクネマルアタマボルト	BOLT	
1-3	021080106	3	ナツト1シユ8	NUT, 1 M8	
1-4	028080242	3	バネザガネ2-8	WASHER, SPRING 2-8	
1-5	025080236	3	ヒラザガネチユウ8	WASHER, PLAIN M 8	
1-6	146254001	6	モータカンザ	COLLAR	
1-7	021080302	12	ナツト3シユ8	NUT, 3 M8	

V. エアー押エ上げ関係 / Pneumatic presser foot lifting mechanism / Pneumatische stoffdrückerfußanhebevorrichtung / Dispositif pneumatique de releveur de pied presseur / Levantador neumático del prensatelas

B256-UT23,24
B257-UT23,44

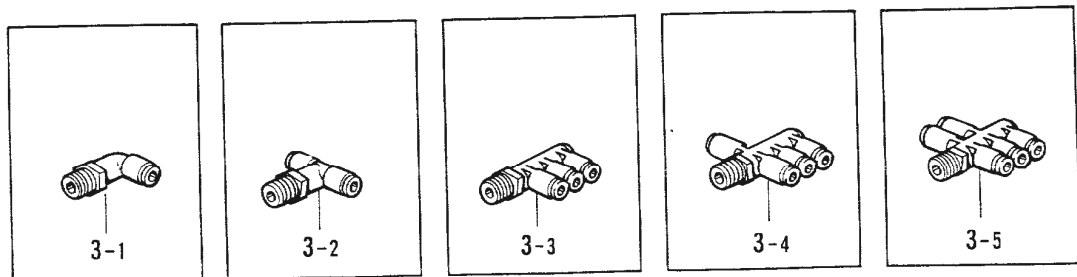
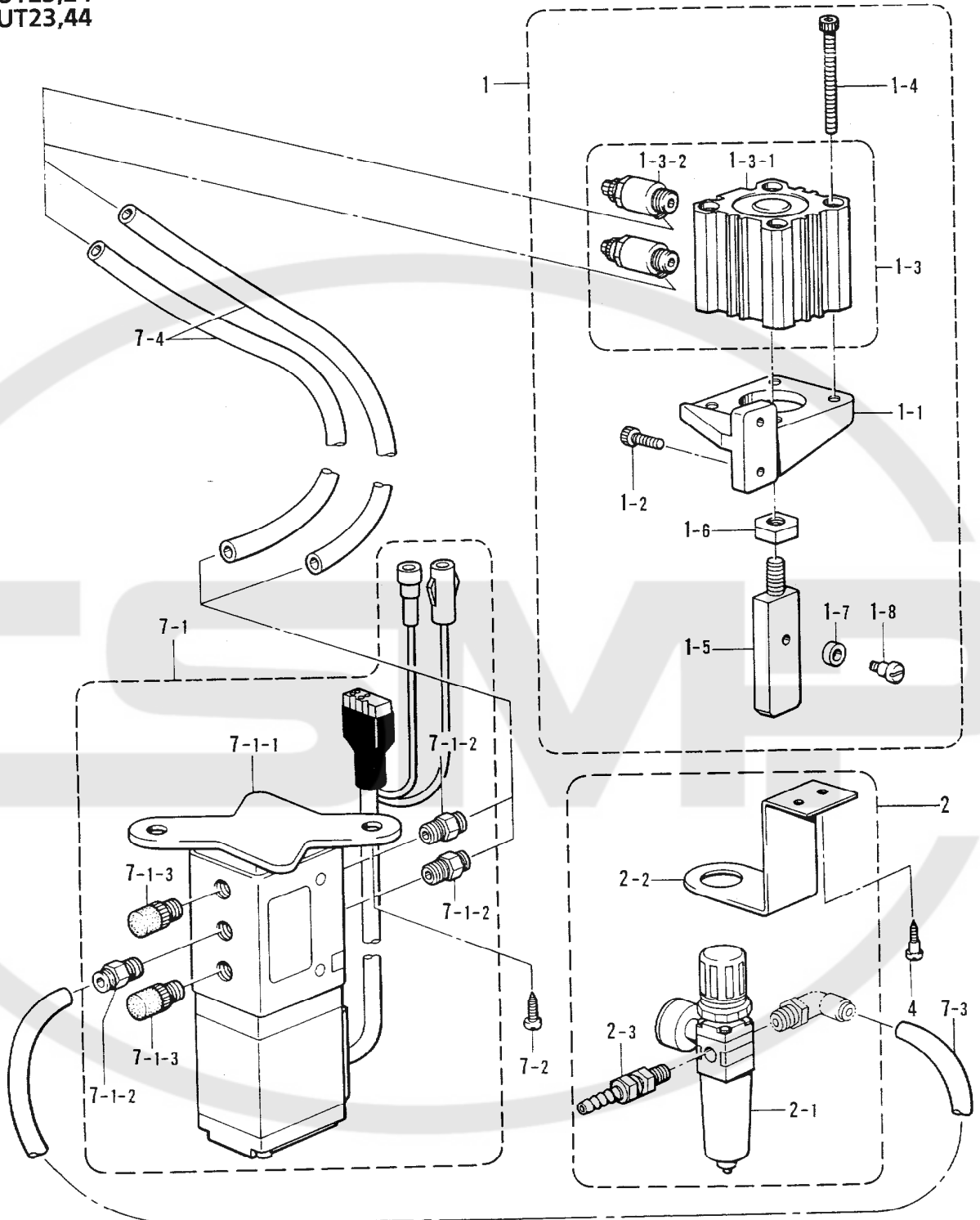

V. エアー押上ゲ関係 / Pneumatic presser foot lifting mechanism / Pneumatische stoffdrückerfußanhebevorrichtung / Dispositif pneumatique de releveur de pied presseur / Levantador neumático del prensatelas

REF.NO.	CODE	Q'TY	品名	NAME OF PARTS	RM
			<B256-UT23,24> <B257-UT23,44>		
1	S28681001	1	オサエアゲシリンダクミ	PRESSER FOOT LIFTING SYLINDER ASSY	
1-1	S28596001	1	シリンダードダイ	CYLINDER BASE	
1-2	018061222	2	アナボルト6X12	BOLT, SOCKET M6X12	
1-3	S28597000	1	エアーシリンダクミ	AIR CYLINDER ASSY	
1-3-1	S28598000	1	エアーシリンダ	AIR CYLINDER	
1-3-2	S28599000	2	スピードコントローラ	SPEED CONTROLLER	
1-4	018505022	4	アナボルト5X50	BOLT, SOCKET M5X50	
1-5	S28600001	1	オサエサドウボウ	PRESSER DRIVING BAR	
1-6	021080302	1	ナツト3シユ8	NUT, 3 M8	
1-7	110167001	1	コロ	ROLLER	
1-8	110168001	1	コロジク	ROLLER SHAFT	
2	S28468001	1	エアーユニットクミ	AIR UNIT ASSY	
2-1	S21352001	1	フィルターレギュレータ	FILTER REGULATOR	
2-2	S21353001	1	エアユニットトリツケイタ	AIR UNIT SET PLATE	
2-3	140678000	1	ホースツギテ	AIR TUBE JOINT	
3-2	S28469000	1	チーズユニオン	T-UNION (2)	
4	101118001	2	マルモクネジ4.5X20	WOOD SCREW, ROUND M4.5X20	
7	S28682001	1	オサエアゲバルブセット	PRESSER FOOT LIFTING VALVE SET	
7-1	S28683001	1	オサエアゲバルブクミ	PRESSER FOOT LIFTING VALVE ASSY	
7-1-1	S28680001	1	ソレノイドバルブクミ	SOLENOID VALVE ASSY	
7-1-2	S01522000	3	ハーフユニオン	HALF UNION	
7-1-3	159874000	2	サイレンサー	SILENCER	
7-2	032422505	2	+マルモクネジ4.1X25	WOOD SCREW, ROUND M4.1X25	
7-3	S28685000	1	エアーチューブ (L=310)	AIR TUBE (L=310)	
7-4	S28686000	2	エアーチューブ (L=900)	AIR TUBE (L=900)	
			<オプションパーツ>	<OPTION PARTS>	
3-1	S04896000	1	エルボユニオン	ELBOW UNION (1)	
3-3	S28470000	1	トリプルバンジョー	TRIPLE JOINT (3)	
3-4	S28471000	1	トリプルバンジョー	TRIPLE JOINT (4)	
3-5	S28472000	1	トリプルバンジョー	TRIPLE JOINT (5)	

W1. 布張ローラ装置関係 / Fabric tension roller device set / Stoffspanrollervorrichtung / Dispositif de rouleaux de tension du tissu / Dispositivo de rodillo tensor de tela

056
0V1
0X6

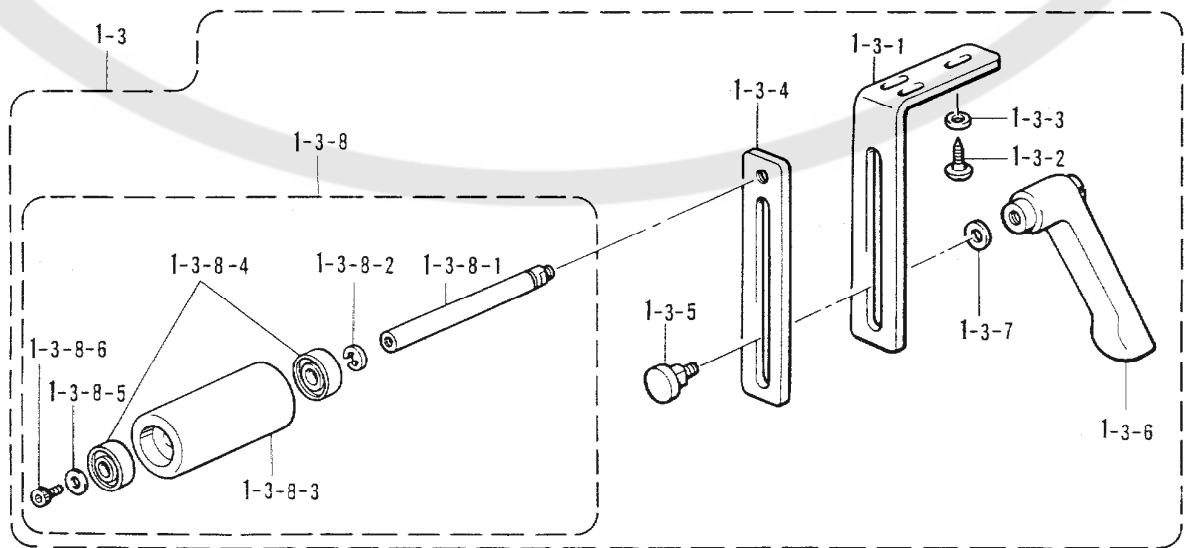
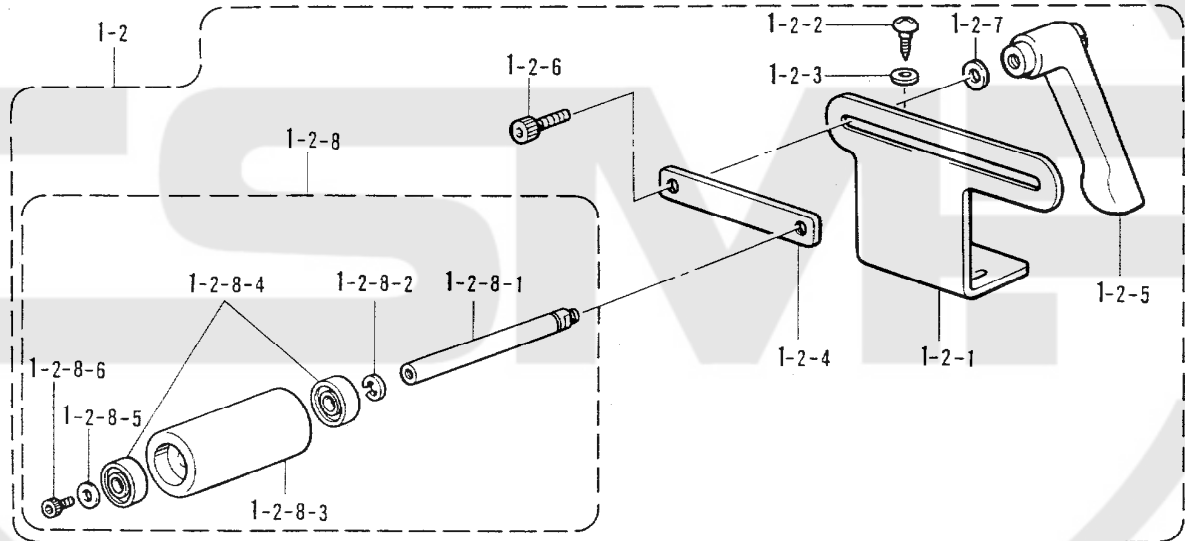
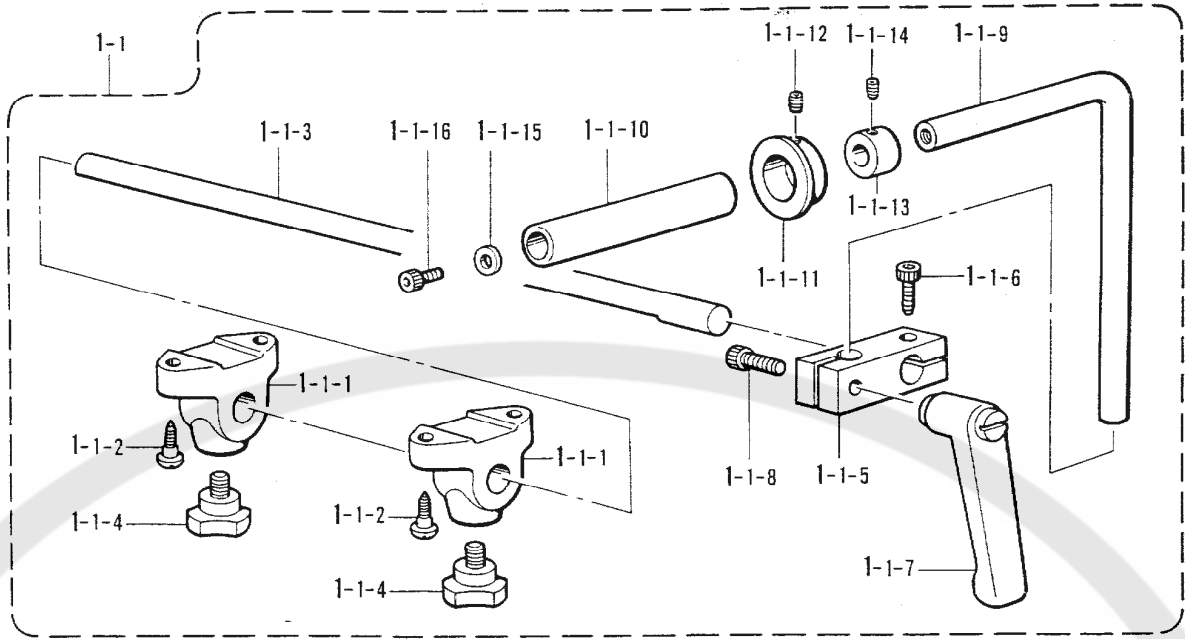

W1. 布張ローラ装置関係 / Fabric tension roller device set / Stoffspannrollervorrichtung /
Dispositif de rouleaux de tension du tissu / Dispositivo de rodillo tensor de tela

REF.NO.	CODE	Q'TY	ヒンメイ	NAME OF PARTS	RM
1	S28687001	1	<056,0V1,0X6> ヌノハリローラソウチクミ	FABRIC TENSION ROLLER DEVICE ASSY	
1-1	S28688001	1	マエローラソウチクミ	FRONT ROLLER ASSY	
1-1-1	S28689001	2	ローラFササエダイ	ROLLER (F) SUPPORT BRACKET	
1-1-2	031452206	4	マルモク45X22	WOOD SCREW, ROUND M4.5X22	
1-1-3	S28690001	1	ローラゼンゴジク	ROLLER LONGITUDINAL SHAFT	
1-1-4	S28691000	2	ノブボルトM10	KNOB BOLT M10	
1-1-5	S28692001	1	ローラツギテ	ROLLER JOINT	
1-1-6	018082022	1	アナボルト8X20	BOLT, SOCKET M8X20	
1-1-7	S28693000	1	クランプレバーM8	CLAMP LEVER (M8)	
1-1-8	018082522	1	アナボルト8X25	BOLT, SOCKET M8X25	
1-1-9	S28694001	1	ローラFササエジク	ROLLER (F) SUPPORT SHAFT	
1-1-10	S28695000	1	ローラF	ROLLER (F)	
1-1-11	S28696001	1	ローラFカラー	ROLLER (F) COLLAR	
1-1-12	014680422	1	アナトメネジ4.37クボミ	SET SCREW, SOCKET (CP) M4.37	
1-1-13	153788001	1	セットカラー	SET COLLAR	
1-1-14	014770622	2	アナトメネジ6.35クボミ	SET SCREW, SOCKET (CP) M6.35	
1-1-15	118735002	1	ザガネ	WASHER	
1-1-16	018060822	1	アナボルト6X8	BOLT, SOCKET M6X8	
1-2	S28697001	1	ウシロローラソウチクミ	REAR ROLLER ASSY	
1-2-1	S28698001	1	ローラBドダイ	ROLLER (B).BASE	
1-2-2	031452206	3	マルモク45X22	WOOD SCREW, ROUND M4.5X22	
1-2-3	146354001	3	ザガネ	WASHER	
1-2-4	S28699001	1	ローラBササエイタ	ROLLER (B) SUPPORT PLATE	
1-2-5	S28693000	1	クランプレバーM8	CLAMP LEVER (M8)	
1-2-6	018082022	1	アナボルト8X20	BOLT, SOCKET M8X20	
1-2-7	025080232	1	ヒラザガネチユウ8	WASHER, PLAIN M 8	
1-2-8	S28746001	1	ローラクミ	ROLLER ASSY	
1-2-8-1	S28700001	1	ローラササエジク	ROLLER SUPPORT SHAFT	
1-2-8-2	048080342	1	トメワE8	RETAINING RING, E8	
1-2-8-3	S28701000	1	ローラ	ROLLER	
1-2-8-4	076000800	2	タマジクウケ6000ZZ	BALL BEARING, 6000ZZ	
1-2-8-5	025060332	1	ヒラザガネダイ6	WASHER, PLAIN L 6	
1-2-8-6	018060822	1	アナボルト6X8	BOLT, SOCKET M6X8	
1-3	S28705001	1	シタローラソウチクミ	LOWER ROLLER ASSY	
1-3-1	S28702001	1	ローラDドダイ	ROLLER (D) BASE	
1-3-2	031452206	3	マルモク45X22	WOOD SCREW, ROUND M4.5X22	
1-3-3	146354001	3	ザガネ	WASHER	
1-3-4	S28703001	1	ローラDササエイタ	ROLLER (D) SUPPORT PLATE	
1-3-5	S28704001	1	クランプネジ	CLAMP SCREW	
1-3-6	S28693000	1	クランプレバーM8	CLAMP LEVER (M8)	
1-3-7	025080232	1	ヒラザガネチユウ8	WASHER, PLAIN M 8	
1-3-8	S28746001	1	ローラクミ	ROLLER ASSY	
1-3-8-1	S28700001	1	ローラササエジク	ROLLER SUPPORT SHAFT	
1-3-8-2	048080342	1	トメワE8	RETAINING RING, E8	
1-3-8-3	S28701000	1	ローラ	ROLLER	
1-3-8-4	076000800	2	タマジクウケ6000ZZ	BALL BEARING, 6000ZZ	
1-3-8-5	025060332	1	ヒラザガネダイ6	WASHER, PLAIN L 6	
1-3-8-6	018060822	1	アナボルト6X8	BOLT, SOCKET M6X8	

W2. 布張ローラ装置関係 / Fabric tension roller device set / Stoffspannrollervorrichtung / Dispositif de rouleaux de tension du tissu / Dispositivo de rodillo tensor de tela

0W1

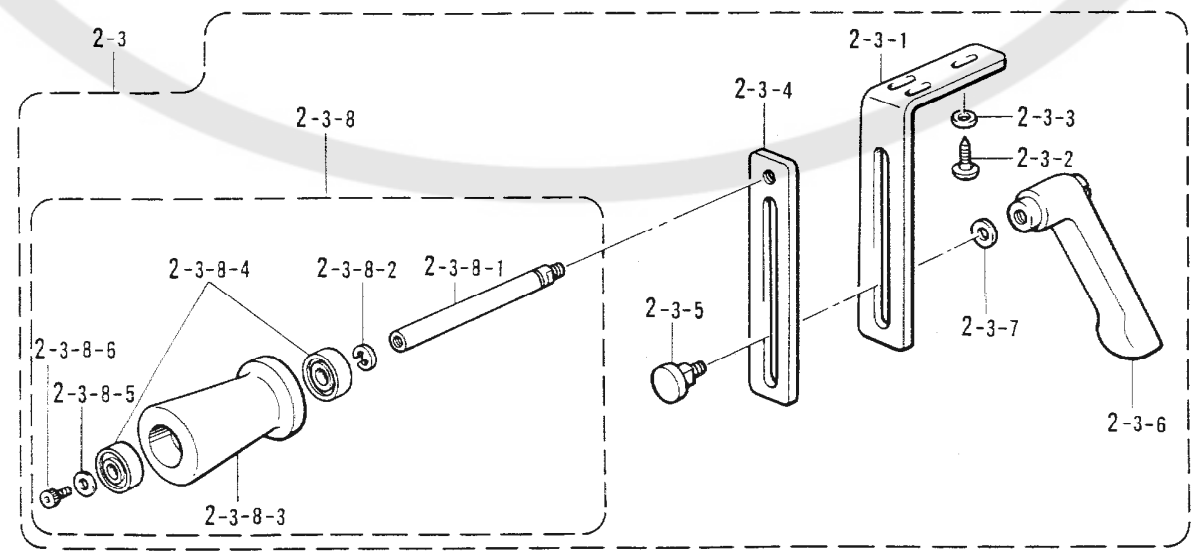
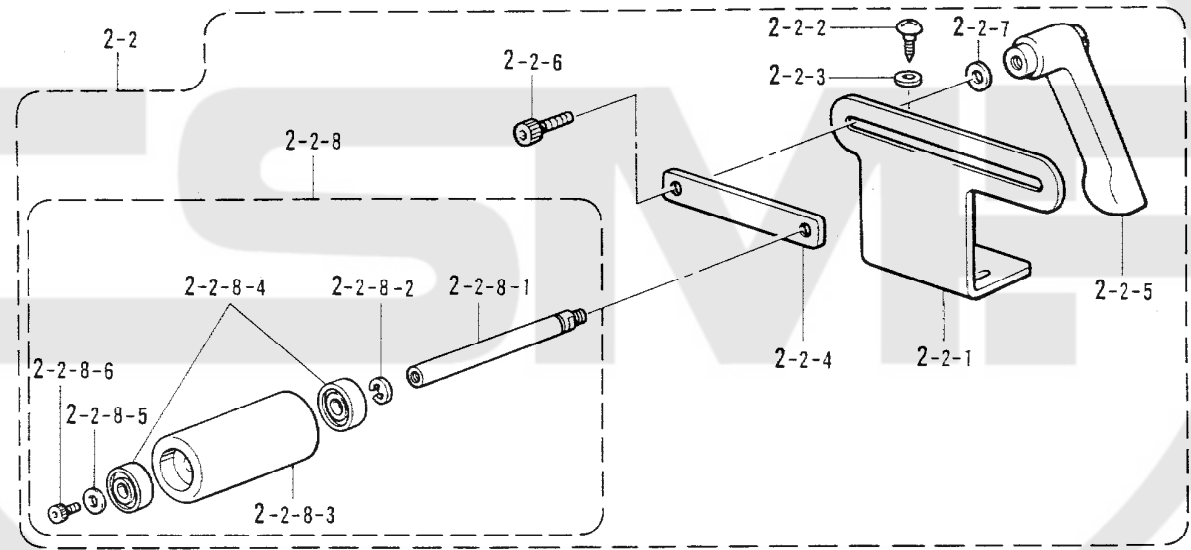
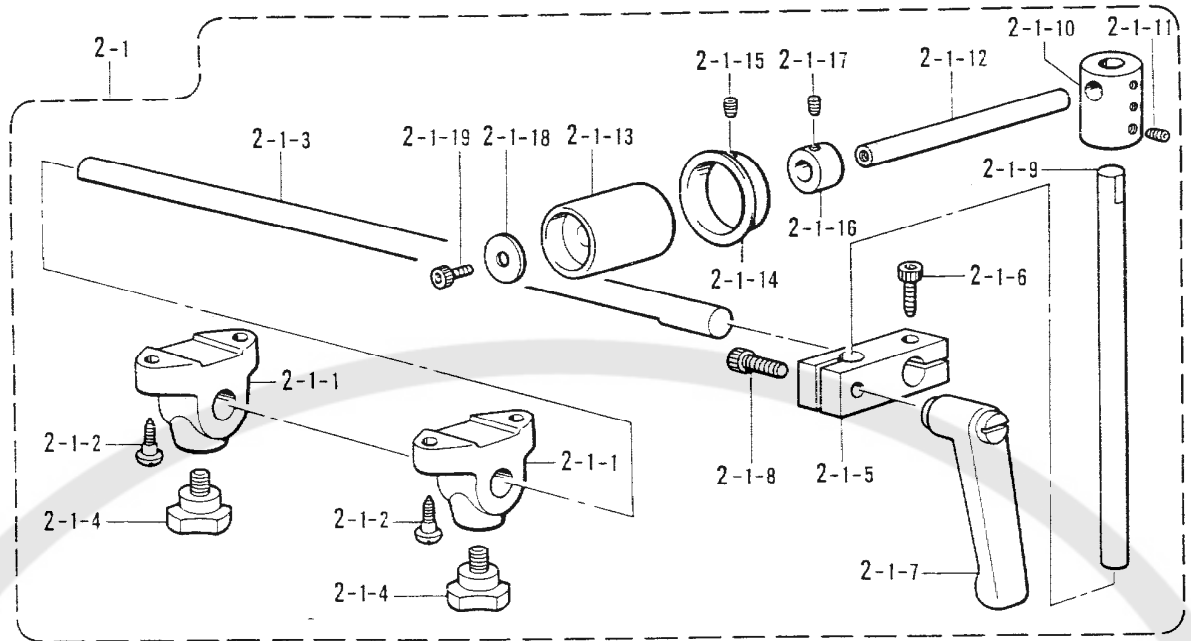

118-256,257-963

W2. 布張ローラ装置関係 / Fabric tension roller device set / Stoffspannrollervorrichtung /
Dispositif de rouleaux de tension du tissu / Dispositivo de rodillo tensor de tela

REF.NO.	CODE	Q'TY	ヒンメイ	NAME OF PARTS	RM
2	S28706001	1	<0W1> ヌノハリローラソウチクミ	FABRIC TENSION ROLLER DEVICE ASSY	
2-1	S28707001	1	マエローラソウチクミ	FRONT ROLLER ASSY	
2-1-1	S28689001	2	ローラFササエダイ	ROLLER (F) SUPPORT BRACKET	
2-1-2	031452206	4	マルモク45X22	WOOD SCREW, ROUND M4.5X22	
2-1-3	S28690001	1	ローラゼンゴジク	ROLLER LONGITUDINAL SHAFT	
2-1-4	S28691000	2	ノブボルトM10	KNOB BOLT M10	
2-1-5	S28692001	1	ローラツギテ	ROLLER JOINT	
2-1-6	018082022	1	アナボルト8X20	BOLT, SOCKET M8X20	
2-1-7	S28693000	1	クランプレバーM8	CLAMP LEVER (M8)	
2-1-8	018082522	1	アナボルト8X25	BOLT, SOCKET M8X25	
2-1-9	S28708001	1	ローラFタテジク	ROLLER (F) VERTICAL SHAFT	
2-1-10	S28709001	1	ローラFツギテ	ROLLER (F) JOINT	
2-1-11	014770622	3	アナトメネジ6.35クボミ	SET SCREW, SOCKET (CP) M6.35	
2-1-12	S28710001	1	ローラFジク	ROLLER (F) SHAFT	
2-1-13	S28711000	1	ローラF	ROLLER (F)	
2-1-14	S28712001	1	ローラFカラー	ROLLER (F) COLLAR	
2-1-15	014770622	1	アナトメネジ6.35クボミ	SET SCREW, SOCKET (CP) M6.35	
2-1-16	153788001	1	セツトカラー	SET COLLAR	
2-1-17	014770622	2	アナトメネジ6.35クボミ	SET SCREW, SOCKET (CP) M6.35	
2-1-18	025060332	1	ヒラザガネダイ6	WASHER, PLAIN L 6	
2-1-19	018060822	1	アナボルト6X8	BOLT, SOCKET M6X8	
2-2	S28697001	1	ウシロローラソウチクミ	REAR ROLLER ASSY	
2-2-1	S28698001	1	ローラBダイ	ROLLER (B) BASE	
2-2-2	031452206	3	マルモク45X22	WOOD SCREW, ROUND M4.5X22	
2-2-3	146354001	3	ザガネ	WASHER	
2-2-4	S28699001	1	ローラBササエイタ	ROLLER (B) SUPPORT PLATE	
2-2-5	S28693000	1	クランプレバーM8	CLAMP LEVER (M8)	
2-2-6	018082022	1	アナボルト8X20	BOLT, SOCKET M8X20	
2-2-7	025080232	1	ヒラザガネチユウ8	WASHER, PLAIN M 8	
2-2-8	S28746001	1	ローラクミ	ROLLER ASSY	
2-2-8-1	S28700001	1	ローラササエジク	ROLLER SUPPORT SHAFT	
2-2-8-2	048080342	1	トメワE8	RETAINING RING, E8	
2-2-8-3	S28701000	1	ローラ	ROLLER	
2-2-8-4	076000800	2	タマジクウケ6000ZZ	BALL BEARING, 6000ZZ	
2-2-8-5	025060332	1	ヒラザガネダイ6	WASHER, PLAIN L 6	
2-2-8-6	018060822	1	アナボルト6X8	BOLT, SOCKET M6X8	
2-3	S28714001	1	シタローラソウチクミ	LOWER ROLLER ASSY	
2-3-1	S28702001	1	ローラDダイ	ROLLER (D) BASE	
2-3-2	031452206	3	マルモク45X22	WOOD SCREW, ROUND M4.5X22	
2-3-3	146354001	3	ザガネ	WASHER	
2-3-4	S28703001	1	ローラDササエイタ	ROLLER (D) SUPPORT PLATE	
2-3-5	S28704001	1	クランプネジ	CLAMP SCREW	
2-3-6	S28693000	1	クランプレバーM8	CLAMP LEVER (M8)	
2-3-7	025080232	1	ヒラザガネチユウ8	WASHER, PLAIN M 8	
2-3-8	S28747001	1	ローラクミ	ROLLER ASSY	
2-3-8-1	S28700001	1	ローラササエジク	ROLLER SUPPORT SHAFT	
2-3-8-2	048080342	1	トメワE8	RETAINING RING, E8	
2-3-8-3	S28716000	1	ローラ	ROLLER	
2-3-8-4	076000800	2	タマジクウケ6000ZZ	BALL BEARING, 6000ZZ	
2-3-8-5	025060332	1	ヒラザガネダイ6	WASHER, PLAIN L 6	
2-3-8-6	018060822	1	アナボルト6X8	BOLT, SOCKET M6X8	

X1. 付属アタッチメント / Attachment set / Anbausatz / Jeu d'accessoires / Juego de fijación

056 0X1
 OV1 0X6
 OW1

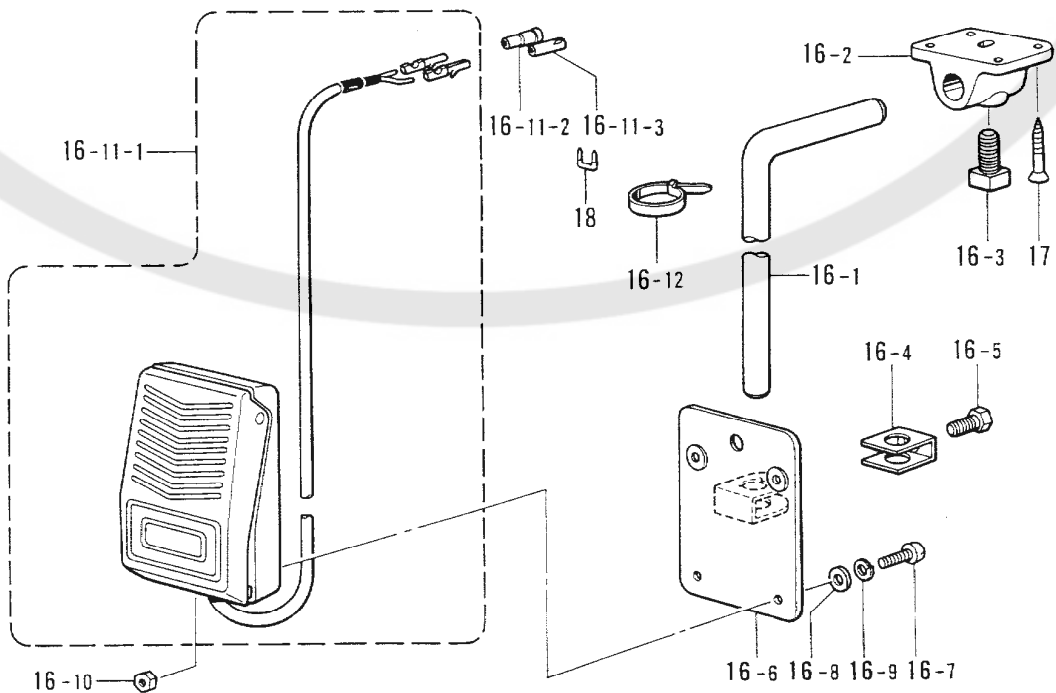
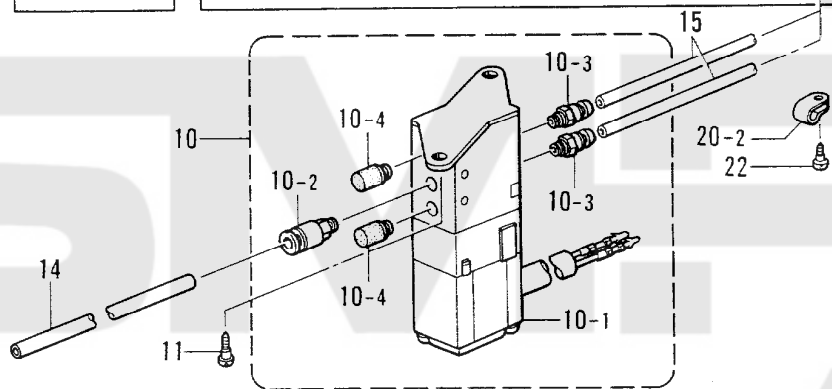
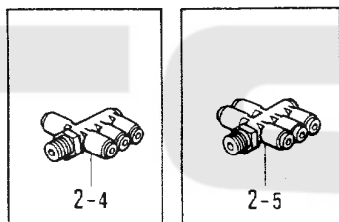
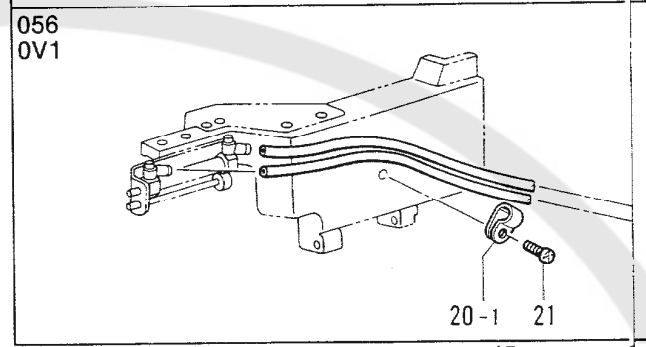
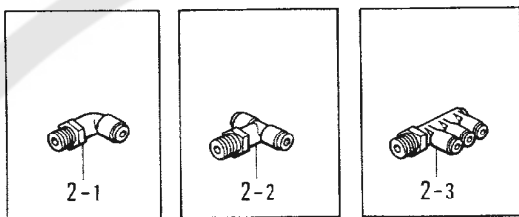
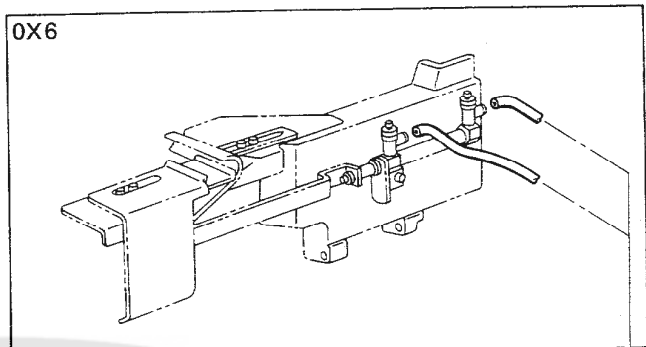
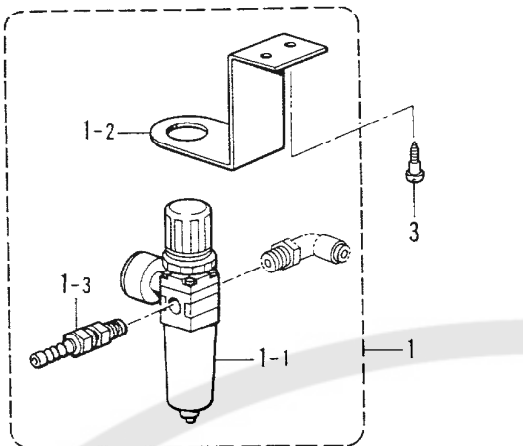

118-256,257-964

X1. 付属アタッチメント / Attachment set / Anbausatz / Jeu d'accessoires / Juego de fijación

REF.NO.	CODE	Q'TY	ヒンメイ	NAME OF PARTS	RM
<056,0V1,0W1,0X1,0X6>					
1	S28468001	1	エアユニットクミ	AIR UNIT ASSY	
1-1	S21352001	1	フィルターレギュレータ	FILTER REGULATOR	
1-2	S21353001	1	エアユニットトリツケイタ	AIR UNIT SET PLATE	
1-3	140678000	1	ホースツギテ	AIR TUBE JOINT	
2-1	S04896000	1	エルボユニオン	ELBOW UNION (1)	
2-2	S28469000	1	チーズユニオン	T-UNION (2)	
2-3	S28470000	1	トリプルバンジヨー	TRIPLE JOINT (3)	
2-4	S28471000	1	トリプルバンジヨー	TRIPLE JOINT (4)	
2-5	S28472000	1	トリプルバンジヨー	TRIPLE JOINT (5)	
3	101118001	2	マルモクネジ4.5X20	WOOD SCREW, ROUND M4.5X20	
<056,0V1,0X6>					
10	S28726001	1	ソレノイドバルブクミ	SOLENOID VALVE ASSY	
10-1	S28727000	1	ソレノイドバルブ	SOLENOID VALVE	
10-2	S14145000	1	ハーフユニオン06-M5	HALF UNION 06-M5	
10-3	S28742000	2	ハーフユニオン	HALF UNION	
10-4	153269001	2	サイレンサー	SILENCER	
11	031311302	2	マルモクネジ3.1X13	WOOD SCREW, ROUND M3.1X13	
14	S28685000	1	エアチューブ (L=310)	AIR TUBE (L=310)	
15	S28730000	2	エアチューブ (L=930)	AIR TUBE (L=930)	
16	S28720009	1	ヒザスイッチクミ	KNEE SWITCH ASSY	
16-1	142026003	1	ヒザスイツチタテジク	KNEE SWITCH SHAFT	
16-2	142027001	1	ヒザスイツチタテジクウケ	KNEE SWITCH SHAFT BRACKET	
16-3	100463001	1	4カクボルト7.94	BOLT, M7.94	
16-4	114967001	1	ヒザアテストツバ	KNEE LIFTER PLATE STOPPER	
16-5	110087001	1	ボルト5.95	BOLT, M5.95	
16-6	S07027001	1	ヒザスイツチトリツケイタ	KNEE LIFTER SWITCH PLATE	
16-7	062401006	4	ナベコ4X10	SCREW, PAN M4X10	
16-8	025040233	4	ヒラザガネチユウ4	WASHER, PLAIN M4	
16-9	028040243	4	バネザガネ2-4	WASHER, SPRING 2-4	
16-10	021400164	4	ナツト1シユ4	NUT, 1 M4	
16-11	S28721009	1	スイッチコードクミ	SWITCH CORD ASSY	
16-11-1	S28722009	1	フツトスイッチクミ	FOOT SWITCH ASSY	
16-11-2	146046000	1	ナイロンコネクター	NYLON CONNECTOR	
16-11-3	146194000	1	ナイロンコネクター	NYLON CONNECTOR	
16-12	149799000	1	タイラツプS	BEAD BAND (S)	
17	034422503	4	+サラモクネジ4.1X25	WOOD SCREW, FLAT M4.1X25	
18	200190001	1	ステツプル	STAPLE	
20-2	S00480000	1	コードホルダ#5	CORD HOLDER (5N)	
22	031311302	1	マルモクネジ3.1X13	WOOD SCREW, ROUND M3.1X13	
<056,0V1>					
20-1	S00480000	1	コードホルダ#5	CORD HOLDER (5N)	
21	062680712	1	ナベコ437-40X7	SCREW, PAN M4.37-40X7	

X2. 付属アタッチメント / Attachment set / Anbausatz / Jeu d'accessoires / Juego de fijación

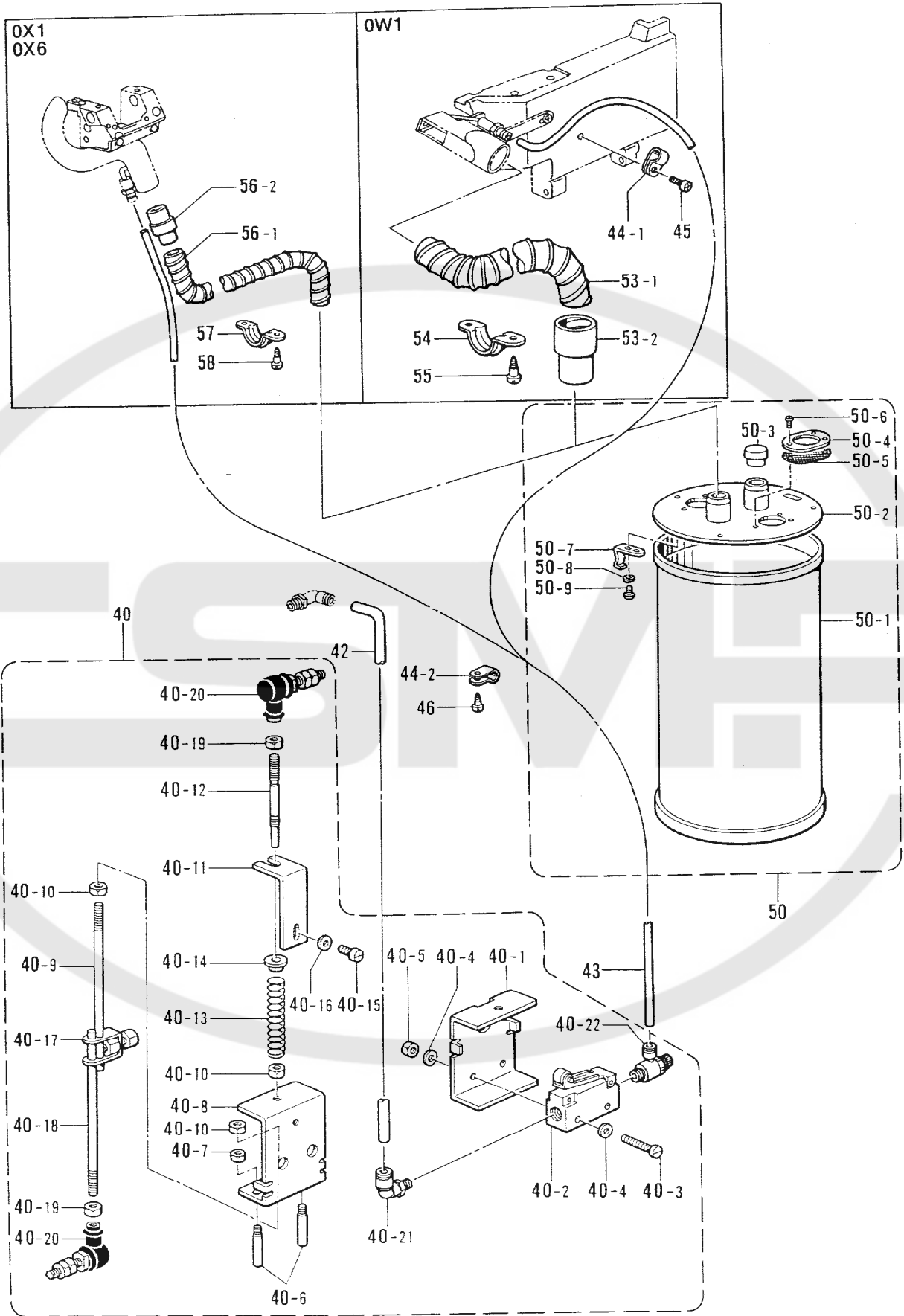

X2. 付属アタッチメント / Attachment set / Anbausatz / Jeu d'accessoires / Juego de fijación

REF.NO.	CODE	Q'TY	ヒンメイ	NAME OF PARTS	RM
<0W1,0X1,0X6>					
40	S28473001	1	レンカンクミ	CONNECTING ROD ASSY	
40-1	S21356001	1	バルブトリツケイタ	VALVE SET PLATE	
40-2	S01561000	1	メカバルブ	MICRO VALVE	
40-3	007402516	2	ヒラネジ4X25	SCREW, FLAT M4X25	
40-4	025040236	4	ヒラザガネチユウ4	WASHER, PLAIN M4	
40-5	021400106	2	ナツト1シユ4	NUT, 1 M4	
40-6	S21357001	2	ガイドピン	PIN	
40-7	021400206	4	2シユナツト4	NUT, 2 M4	
40-8	S21358001	1	バルブサドウイタ	VALVE DIFFERENTIAL PLATE	
40-9	146695001	1	レンカンナカ	CONNECTING ROD INNER	
40-10	021060306	3	3シユナツト6	NUT, 3 M6	
40-11	S21359001	1	バネチヨウセツイタ	SPRING ADJUST PLATE	
40-12	S21360001	1	レンカンU	CONNECTING ROD (U)	
40-13	S21361001	1	オシバネA	SPRING (A)	
40-14	S21362000	1	バネウケ	SPRING HOLDER	
40-15	060400616	1	バインドM4X6	SCREW, BIND M4X6	
40-16	025040236	1	ヒラザガネチユウ4	WASHER, PLAIN M4	
40-17	181225001	1	レンカンダキクミ	CONNECTING ROD CLAMP ASSY	
40-18	146695001	1	レンカンナカ	CONNECTING ROD INNER	
40-19	021060306	2	3シユナツト6	NUT, 3 M6	
40-20	119712001	2	ジョイントクミ	JOINT ASSY	
40-21	S01542000	1	エルボユニオン61	ELBOW UNION 61	
40-22	S23647000	1	スピードコントローラ	SPEED CONTROLLER	
42	S28474000	1	エアチューブ (L = 480)	AIR TUBE (L = 480)	
43	S08138000	1	エアホースS-A (L = 1030)	AIR TUBE S-A (L = 1030)	
44-2	S10243000	1	ナイロンクランプNK-3N	CORD HOLDER (NK-3N)	
46	031311302	1	マルモクネジ3.1X13	WOOD SCREW, ROUND M3.1X13	
50	147246101	1	フィルタボックスクミ	FILTER BOX ASSY	
50-1	147247009	1	フィルタボックス	FILTER BOX	
50-2	147248009	1	フィルタボックスフタクミ	FILTER BOX COVER ASSY	
50-3	147251009	1	メクラセン	OIL CAP	
50-4	144625009	2	ロカモウオサエ	FILTER FLANGE	
50-5	147252000	2	フィルタ	FILTER	
50-6	060670512	6	バインド357-40X5	SCREW, BIND M3.57-40X5	
50-7	111032001	3	メンイタトメイタバネL	STOPPER PLATE SPRING (L)	
50-8	105248003	3	ザガネ	WASHER	
50-9	S01297001	3	シメネジ3.57X3.5	SCREW, M3.57X3.5	
<0W1>					
44-1	S10243000	1	ナイロンクランプNK-3N	CORD HOLDER (NK-3N)	
45	062680712	1	ナベコ437-40X7	SCREW, PAN M4.37-40X7	
53	S28476000	1	ホースクミ	HOSE ASSY	
53-1	S28477000	1	ホース (L = 1500)	HOSE (L = 1500)	
53-2	S28478000	1	カフス	CUFFS	
54	143359001	3	サドル	SADDLE	
55	101118001	6	マルモクネジ4.5X20	WOOD SCREW, ROUND M4.5X20	
<0X1,0X6>					
56	S28479000	1	ホースクミ	HOSE ASSY	
56-1	S28480000	1	ホース (L = 1500)	HOSE (L = 1500)	
56-2	S28481000	1	カフス	CUFFS	
57	S28745001	3	サドルバンド	SADDLE BAND	
58	031311302	6	マルモクネジ3.1X13	WOOD SCREW, ROUND M3.1X13	

118-256,257-964

X3. 付属アタッチメント / Attachment set / Anbausatz / Jeu d'accessoires / Juego de fijación

<オプションパーツ / OPTION PARTS>

<右メス用ヒザ上げレバー装置 / Knee lifer device for right knife>

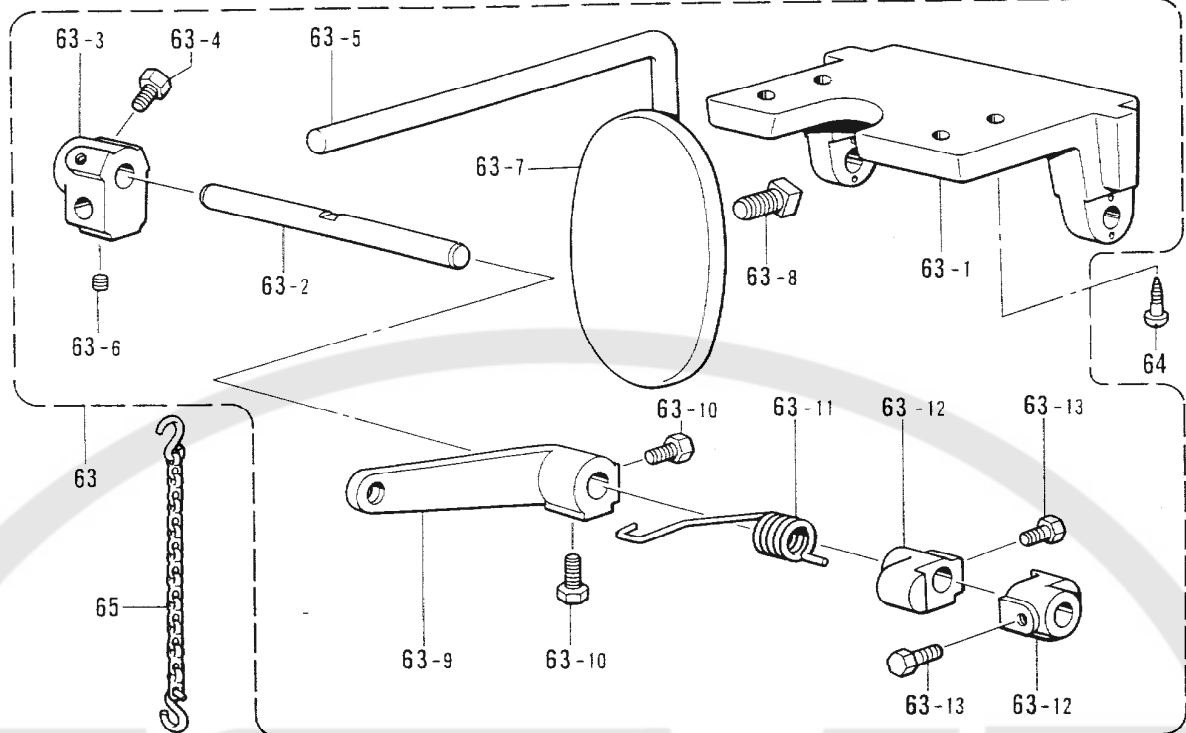

<コンデンスステッチ装置 / Condense stitch device>

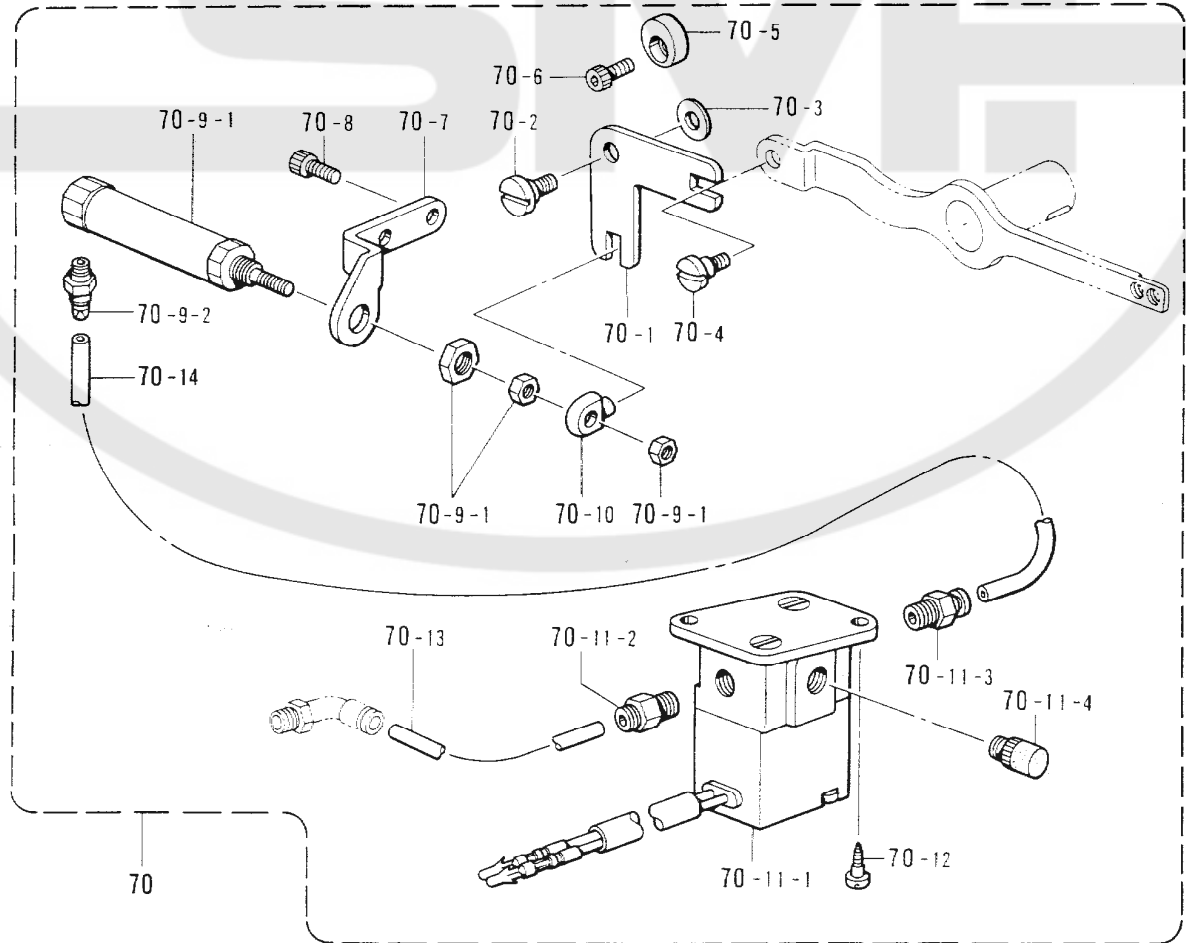

X3. 付属アタッチメント / Attachment set / Anbausatz / Jeu d'accessoires / Juego de fijación

REF.NO.	CODE	Q'TY	ヒンメイ	NAME OF PARTS	RM
			<オプションパーツ>	<OPTION PARTS>	
63	155196309	1	サドウチヨウセツソウチクミ	KNEE LIFTER DEVICE ASSY	
63-1	155197101	1	ヒザアテヨコジクウケ	KNEE LIFTER SHAFT BRACKET	
63-2	155198101	1	ヨコジク	KNEE LIFTER SHAFT	
63-3	155199101	1	ヒザアテツギテ	KNEE LIFTER BRACKET	
63-4	017781012	2	ボルト6.35X10	BOLT, M6.35X10	
63-5	148797001	1	ヒザアゲタテジクS	KNEE LIFTER BAR (S)	
63-6	014780622	1	アナトメネジ6.35クボミ	SET SCREW, SOCKET (CP) M6.35	
63-7	148798009	1	ヒザアテL	KNEE LIFTER PLATE (L)	
63-8	100463001	1	4カクボルト7.94	BOLT, M7.94	
63-9	155201101	1	ヒザアテレバー	KNEE LIFTER LEVER	
63-10	017781012	2	ボルト6.35X10	BOLT, M6.35X10	
63-11	155202001	1	ヒザアテレバーバネ	SPRING	
63-12	S21378001	2	ヨコジクトメグ	COLLAR	
63-13	017781012	4	ボルト6.35X10	BOLT, M6.35X10	
64	032422505	4	+マルモクネジ4.1X25	WOOD SCREW, ROUND M4.1X25	
65	S28357001	1	クサリクミ	CHAIN ASSY	
			<オプションパーツ>	<OPTION PARTS>	
70	S28731001	1	コンデンスステツチソウチクミ	CONDENSE STITCH DEVICE SET	
70-1	S28732001	1	コンデンスステツチレバー	CONDENSE STITCH LEVER	
70-2	145480101	1	ダンネジ6.35	STUD SCREW, M6.35	
70-3	151439002	1	ザガネ	WASHER	
70-4	115559002	1	ダンネジ4.76	STUD SCREW, M4.76	
70-5	S28733001	1	レバーストツパ	LEVER STOPPER	
70-6	018680822	1	アナボルト4.37X8	BOLT, SOCKET M4.37X8	
70-7	S28734001	1	シリンダダイ	CYLINDER BRACKET	
70-8	018681022	2	アナボルト4.37X10	BOLT, SOCKET M4.37X10	
70-9	S28735000	1	エアーシリンダクミ	AIR CYLINDER ASSY	
70-9-1	S28736000	1	エアーシリンダ	AIR CYLINDER	
70-9-2	S28742000	1	ハーフユニオン	HALF UNION	
70-10	S28737001	1	レバークドウピン	LEVER DRIVING PIN	
70-11	S28738000	1	ソレノイドバルブクミ	SOLENOID VALVE ASSY	
70-11-1	S28739000	1	ソレノイドバルブ	SOLENOID VALVE	
70-11-2	S01522000	1	ハーフユニオン	HALF UNION	
70-11-3	S04910000	1	ハーフユニオン	HALF UNION	
70-11-4	159874000	1	サイレンサー	SILENCER	
70-12	032422505	2	+マルモクネジ4.1X25	WOOD SCREW, ROUND M4.1X25	
70-13	S28740000	1	エアーチューブ (L = 220)	AIR TUBE (L = 220)	
70-14	S28741000	1	エアーチューブ (L = 300)	AIR TUBE (L = 300)	

Z1. 付属品関係 / Accessories / Zubehör / Accessoires / Accesorios

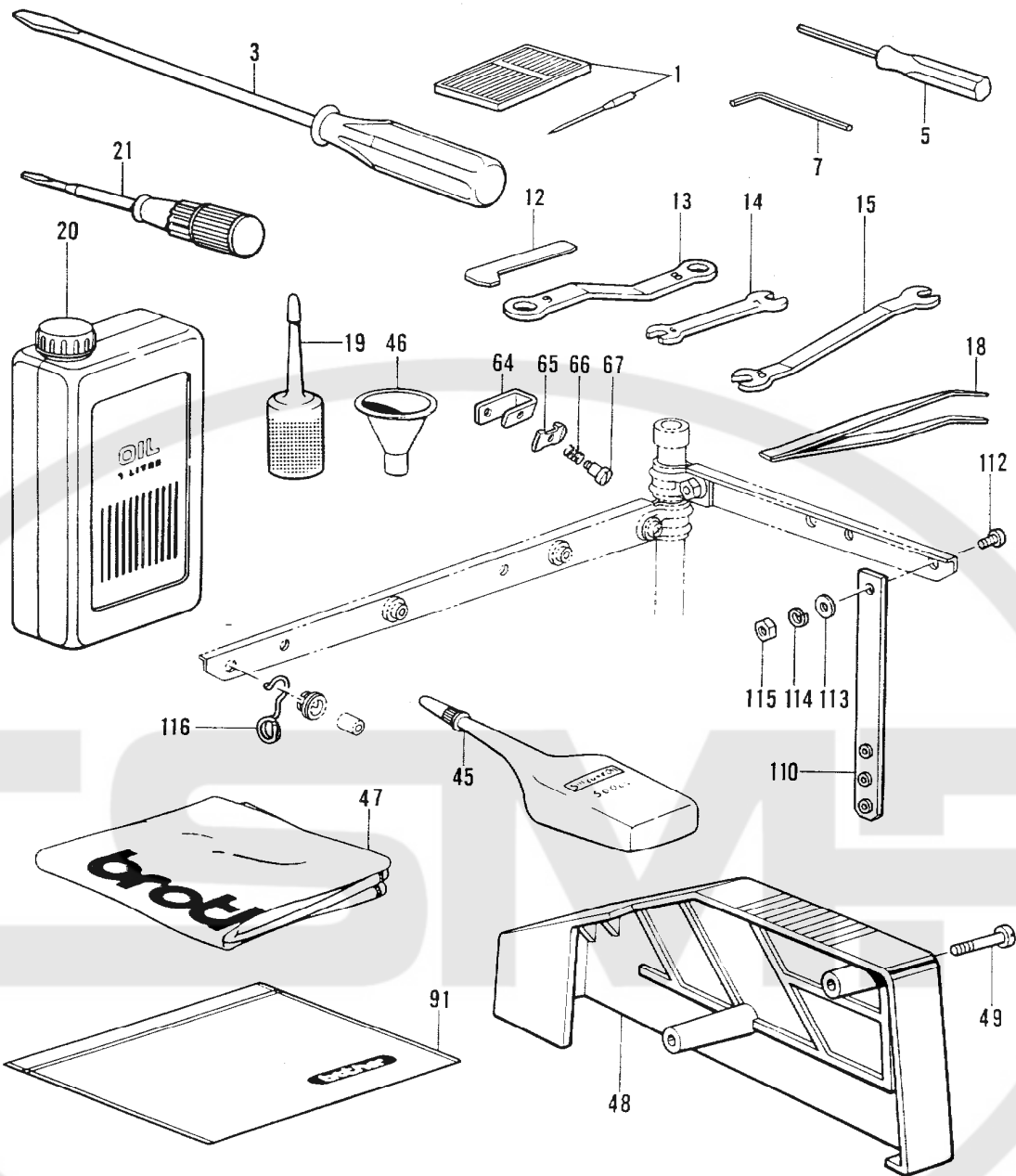

オプションパーツ / OPTION PARTS

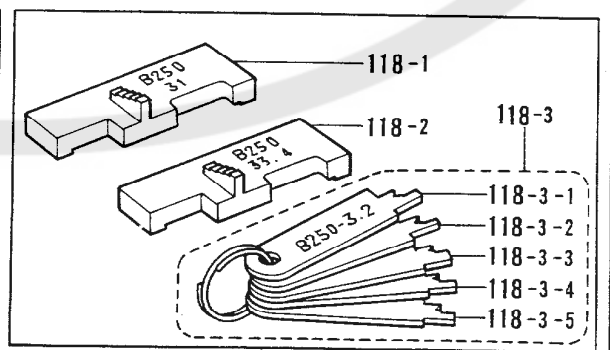
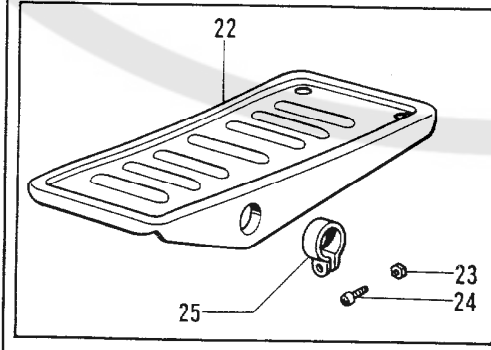

- ◎ 付属品の明細は変更することがあります。
- ◎ The details of included accessories are subject to change.
- ◎ Änderungen in der Aufstellung der Mitgelieferten Zubehöre sind vorbehalten.
- ◎ Les détails des accessoires inclus sont sujets à des changements.
- ◎ Los detalles de los accesorios incluidos pueden variar.

Z1. 付属品関係 / Accessories / Zubehör / Accessoires / Accesorios

REF.NO.	CODE	Q'TY	ヒンメイ	NAME OF PARTS	RM
1	S08715010	10	ミシンハリUYX128GAS	NEEDLE UYX128GAS	
3	101572101	1	ネジマワシ5.5X190	SCREW DRIVER 5.5X190	
5	S01943001	1	6カクボウネジマワシ1.6	SCREW DRIVER 1.6	
7	142721001	1	6カクボウスパナ3	HEXAGONAL WRENCH 3	
12	156309001	1	Lガタネジマワシ	L-TYPE SCREW DRIVER	
13	105343001	1	メガネレンチ8X9	WRENCH 8X9	
14	107779001	1	スパナ6X7	SPANNER 6X7	
15	143566001	1	スパナ8	SPANNER 8	
18	117466000	1	ピンセット	PINCETTE	
19	S06701000	1	ポリオイラークミ	POLY OILER ASSY	
20	145277105	1	オイルタンク	OIL TANK	
21	118837001	1	ネジマワシ3.4X70	SCREW DRIVER 3.4X70	
45	S06704001	1	シリコンオイル	SILICONE OIL	
46	140759000	1	ジヨージョ	FUNNEL	
47	144224001	1	トウブカバー	HEAD COVER	
48	S09002009	1	ベルトカバー	BELT COVER	
49	102424004	2	シメネジ4.37	SCREW, M4.37	
64	S08984001	1	サブテンションダイ	SUB TENSION BASE	
65	112300001	1	ハライトオサエ	NEEDLE THREAD CLAMP	
66	112299001	1	ハライトアンナイオシバネ	COIL SPRING	
67	112301001	1	ダンネジ3.18	STUD SCREW, M3.18	
91	122991001	1	フックヒンポリフクロ	ACCESSORY BAG	
110	S21943001	1	イトアンナイクミ	THREAD GUIDE ASSY	
112	062501006	1	ナベコ5X10	SCREW, PAN M5X10	
113	025050236	1	ヒラザガネチユウ-5	WASHER, PLAIN M 5	
114	028050246	1	バネザガネ2-5	WASHER, SPRING 2-5	
115	021500106	1	1シユナツト5	NUT, 1 M5	
116	S02747101	1	イトカケバネ	SPRING	

			<オプションパーツ>	<OPTION PARTS>	
22	147893009	1	オサエアゲフミイタ	TREADLE PEDAL	
23	021400106	2	ナツト1シユ4	NUT, 1 M4	
24	062401406	2	ナベコ4X14	SCREW, PAN M4X14	
25	116016001	2	ペタルトメ	PEDAL STOPPER	
118	S28887001	1	デアイゲージセット	LOOPER TIMING GAUGE SET	
118-1	S28888001	1	デアイゲージブロックS	GAUGE BLOCK (S)	
118-2	S28889001	1	デアイゲージブロックH	GAUGE BLOCK (H)	
118-3	S28890001	1	デアイゲージイタクミ	GAUGE PLATE ASSY	
118-3-1	S28891001	1	デアイゲージイタ3.2	GAUGE PLATE (3.2)	
118-3-2	S28892001	1	デアイゲージイタ4.0	GAUGE PLATE (4.0)	
118-3-3	S28893001	1	デアイゲージイタ4.8	GAUGE PLATE (4.8)	
118-3-4	S28894001	1	デアイゲージイタ5.6	GAUGE PLATE (5.6)	
118-3-5	S28895001	1	デアイゲージイタ6.4	GAUGE PLATE (6.4)	

22. 付属品関係 / Accessories / Zubehör / Accessoires / Accesorios

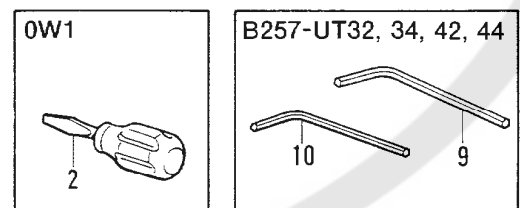
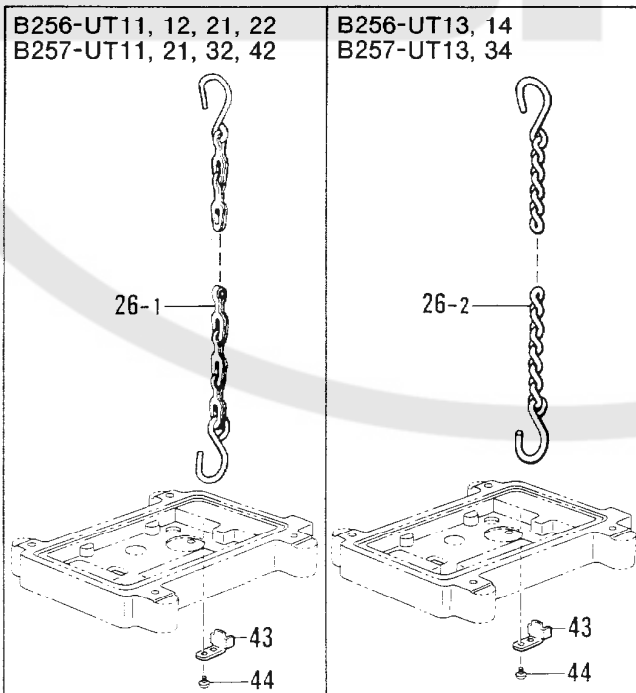
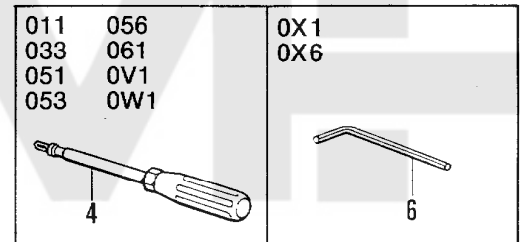
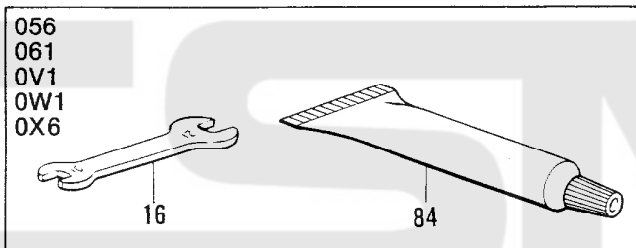
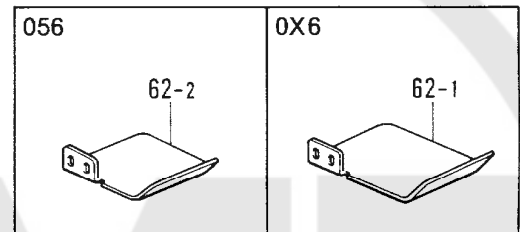
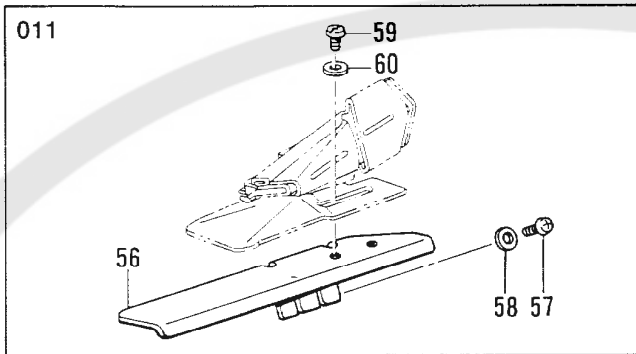
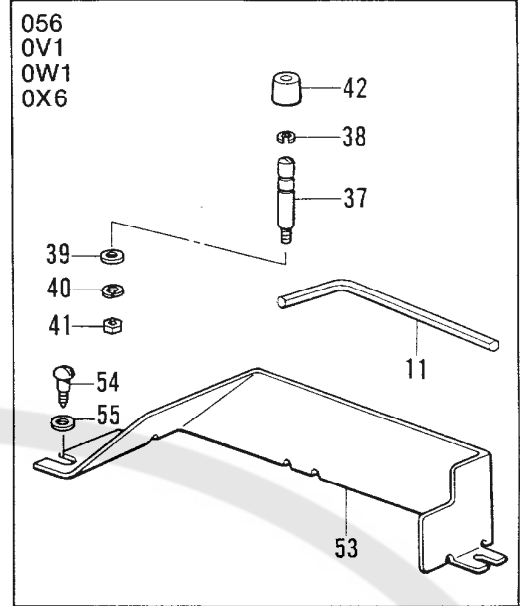
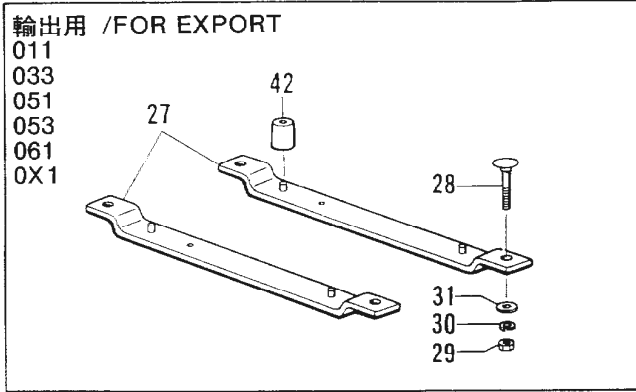

◎ 付属品の明細は変更することがあります。
 ◎ The details of included accessories are subject to change.
 ◎ Änderungen in der Aufstellung der Mitgelieferten Zubehöre sind vorbehalten.
 ◎ Les détails des accessoires inclus sont sujets à des changements.
 ◎ Los detalles de los accesorios incluidos pueden variar.

22. 付属品関係 / Accessories / Zubehör / Accessoires / Accesorios

REF.NO.	CODE	Q'TY	ヒンメイ	NAME OF PARTS	RM
<輸出用 / FOR EXPORT > <011,033,051,053,061,0X1>					
27	528830001	2	-----	HEAD PLATE ASSY	
28	211964001	4	-----	BOLT, M8X55	
29	021080106	4	-----	NUT, 1 M8	
30	028080242	4	-----	WASHER, SPRING 2-8	
31	025080236	4	-----	WASHER, PLAIN M 8	
42	147919002	4	-----	RUBBER CUSHION	
<056,0V1,0W1,0X6>					
11	115157001	1	6カクボウスパナ6	HEXAGONAL WRENCH 6	
37	528441001	4	ボウシンゴムピン	RUBBER CUSHION PIN	
38	528442001	4	トメワU5	RETAINING RING, U5	
39	025060236	4	ヒラザガネチユウ6	WASHER, PLAIN M 6	
40	028060242	4	バネザガネ2-6	WASHER, SPRING 2-6	
41	021060106	4	1シユナツト6	NUT, 1 M6	
42	147919002	4	ボウジンゴム	RUBBER CUSHION	
53	528444001	1	ホジヨベルトカバー	SUB BELT COVER	
54	100666002	3	マルモクネジ5.5X20	SCREW, OVAL M5.5X20	
55	025750132	3	ヒラザガネシヨウ5.56	WASHER, PLAIN S 5.56	
<011>					
56	528445001	1	ホジヨイタ	SUPPORT PLATE	
57	062710812	2	ナベコ476-32X8	SCREW, PAN M4.76-32X8	
58	113431002	2	ザガネ	WASHER	
59	062710812	2	ナベコ476-32X8	SCREW, PAN M4.76-32X8	
60	116662003	2	ザガネ	WASHER	
<056,061,0V1,0W1,0X6>					
16	107780001	1	スパナ10X12	SPANNER 10X12	
84	509021000	1	グリス	GREASE	
<056>					
62-2	528107101	1	ヌノオサエ	CLOTH PRESSER	
<0X6>					
62-1	528105001	1	ヌノオサエ	CLOTH PRESSER	
<011,033,051,053,056,061,0V1,0W1>					
4	146700001	1	6カクボウネジマワシ2	SCREW DRIVER 2	
<0X1,0X6>					
6	146049001	1	6カクボウスパナ2	HEXAGONAL WRENCH 2	
<0W1>					
2	528849000	1	ネジマワシ6X35	SCREW DRIVER 6X35	
<B257-UT32,34,42,44>					
9	118064001	1	6カクボウスパナ4	HEXAGONAL WRENCH 4	
10	154125001	1	6カクボウスパナ2.5	HEXAGONAL WRENCH 2.5	
<B256-UT11,12,21,22>					
<B257-UT11,21,32,42>					
26-1	149247001	1	クサリクミ	CHAIN ASSY	
43	509001101	1	クサリガイド	CHAIN GUIDE	
44	060680712	1	バインド437-40X7	SCREW, BIND M4.37-40X7	
<B256-UT13,14>					
<B257-UT13,34>					
26-2	521942001	1	クサリクミ	CHAIN ASSY	
43	509001101	1	クサリガイド	CHAIN GUIDE	
44	060680712	1	バインド437-40X7	SCREW, BIND M4.37-40X7	

B256

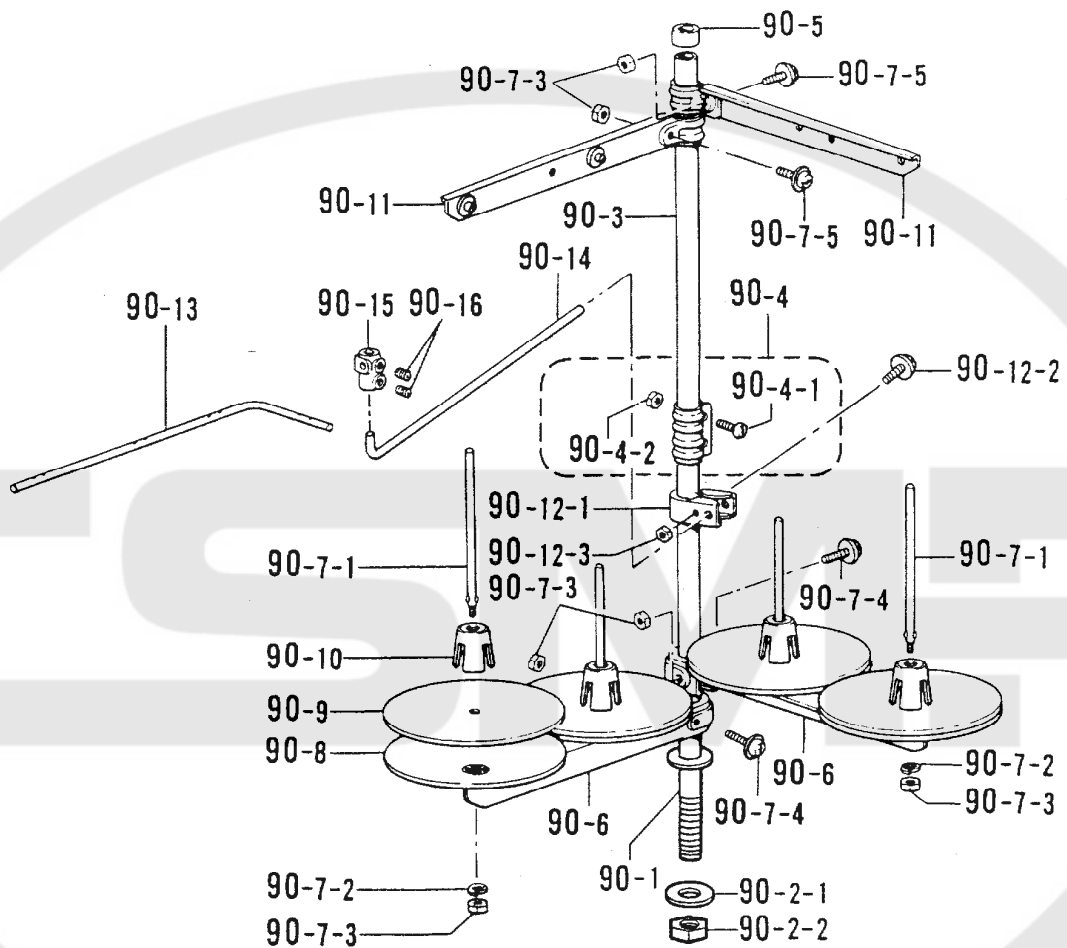

- ◎ 付属品の明細は変更することがあります。
- ◎ The details of included accessories are subject to change.
- ◎ Änderungen in der Aufstellung der Mitgelieferten Zubehöre sind vorbehalten.
- ◎ Les détails des accessoires inclus sont sujets à des changements.
- ◎ Los detalles de los accesorios incluidos pueden variar.

Z3. 付属品関係 / Accessories / Zubehör / Accessoires / Accesorios

REF.NO.	CODE	Q'TY	ヒンメイ	NAME OF PARTS	RM
			< B256 >		
90	S29854009	1	イトタテダイクミ4DTHF	COTTON STAND ASSY 4DTHF	
90-1	156112003	1	コラムパイプD	COLUMN PIPE (D)	
90-2	S02775001	1	パイプネジセットA	PIPE SCREW SET (A)	
90-2-1	150206002	1	ヒラザガネ16	WASHER, PLAIN 16	
90-2-2	150191002	1	6カクナツト5/8	NUT, 5/8	
90-3	150172003	1	コラムパイプ	COLUMN PIPE	
90-4	150106003	1	コラムジョイントクミ	COLUMN JOINT ASSY	
90-4-1	062501406	2	ナベコ5X14	SCREW, PAN M5X14	
90-4-2	021500106	2	1シユナツト5	NUT, 1 M5	
90-5	150174000	1	コラムキャップ	COLUMN CAP	
90-6	S02778002	2	スプールホルダー2	SPOOL HOLDER 2	
90-7	S02780001	2	スプールネジセット2	SPOOL SCREW SET 2	
90-7-1	150179002	4	スプールジクバ	SPOOL SHAFT (B)	
90-7-2	028050246	4	バネザガネ2-5	WASHER, SPRING 2-5	
90-7-3	021500106	8	1シユナツト5	NUT, 1 M5	
90-7-4	0A1503006	2	+ナベザクミ5X30A	SCREW, PAN (P WASHER) M5X30A	
90-7-5	0A1501406	2	+ナベザクミ5X14A	SCREW, PAN (P WASHER) M5X14A	
90-8	150180001	4	ウケザラ	SPOOL STAND BASE	
90-9	150182000	4	スプールマット	SPOOL MAT	
90-10	126863001	4	スプールクツシヨン	SPOOL CUSHION	
90-11	S02786002	2	スレツドハンガークミ2	THREAD HANGER ASSY 2	
90-12	150145009	1	イトアンナイホルダークミ	THREAD GUIDE HOLDER ASSY	
90-12-1	150185009	1	イトアンナイホルダー	THREAD GUIDE HOLDER	
90-12-2	0A1503006	1	+ナベザクミ5X30A	SCREW, PAN (P WASHER) M5X30A	
90-12-3	021500106	1	1シユナツト5	NUT, 1 M5	
90-13	142998101	1	イトアンナイ4	THREAD GUIDE 4	
90-14	S04109001	1	イトアンナイササエボウ	THREAD GUIDE SUPPORT BAR	
90-15	138843001	1	ササエボウツギテ	JOINT	
90-16	014060632	2	アナトメ6X6クボミ	SET SCREW, SOCKET (CP) M6X6	

B257

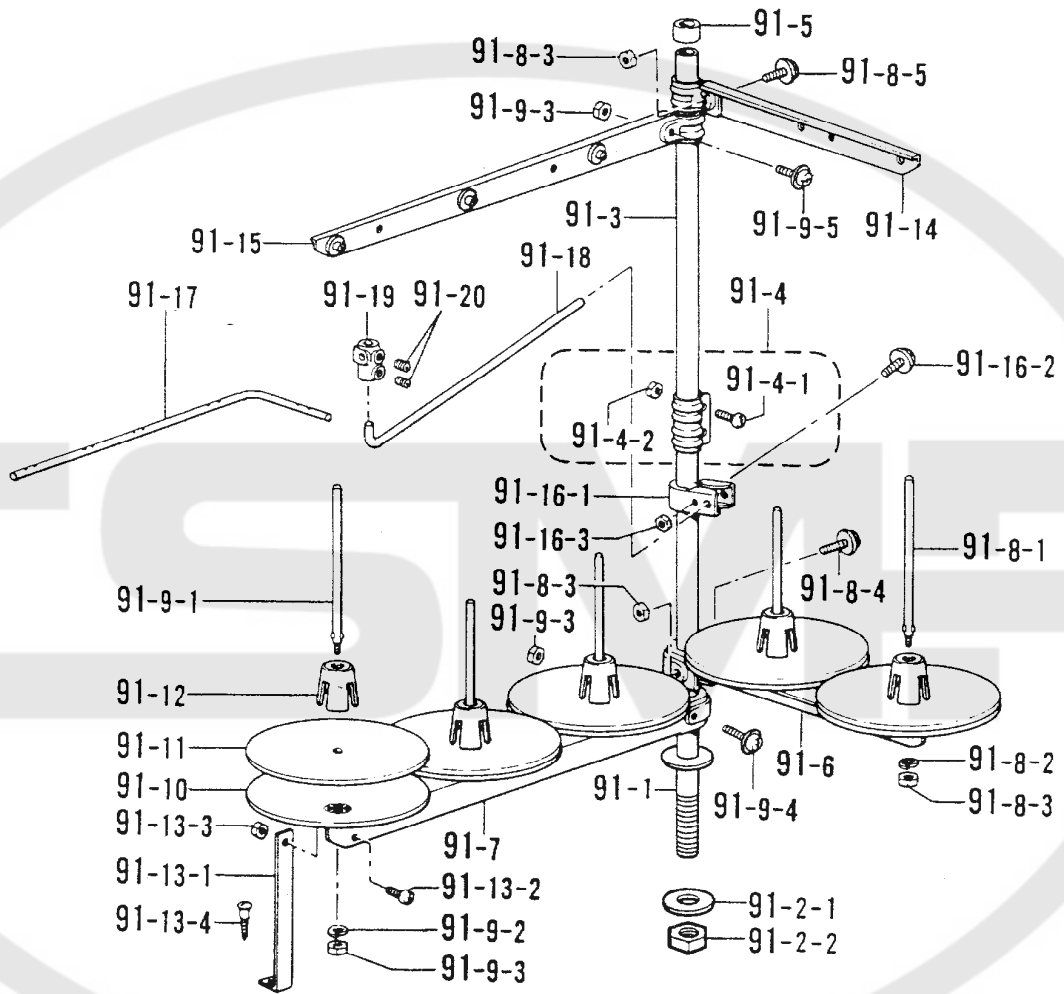

◎ 付属品の明細は変更することがあります。

◎ The details of included accessories are subject to change.

◎ Änderungen in der Aufstellung der Mitgelieferten Zubehöre sind vorbehalten.

◎ Les détails des accessoires inclus sont sujets à des changements.

◎ Los detalles de los accesorios incluidos pueden variar.

Z4. 付属品関係 / Accessories / Zubehör / Accessoires / Accesorios

REF.NO.	CODE	Q'TY	ヒンメイ	NAME OF PARTS	RM
			<B257>		
91	S29855009	1	イトタテダイクミ5DTHF	COTTON STAND ASSY (5DTHF)	
91-1	156112003	1	コラムパイプD	COLUMN PIPE (D)	
91-2	S02775001	1	パイプネジセットA	PIPE SCREW SET (A)	
91-2-1	150206002	1	ヒラザガネ16	WASHER, PLAIN 16	
91-2-2	150191002	1	6カクナツト5/8	NUT, 5/8	
91-3	150172003	1	コラムパイプ	COLUMN PIPE	
91-4	150106003	1	コラムジョイントクミ	COLUMN JOINT ASSY	
91-4-1	062501406	2	ナベコ5X14	SCREW, PAN M5X14	
91-4-2	021500106	2	1シユナツト5	NUT, 1 M5	
91-5	150174000	1	コラムキャツブ	COLUMN CAP	
91-6	S02778002	1	スプールホルダー2	SPOOL HOLDER 2	
91-7	S02779009	1	スプールホルダー3	SPOOL HOLDER 3	
91-8	S02780001	1	スプールネジセット2	SPOOL SCREW SET 2	
91-8-1	150179002	2	スプールジクB	SPOOL SHAFT (B)	
91-8-2	028050246	2	バネザガネ2-5	WASHER, SPRING 2-5	
91-8-3	021500106	4	1シユナツト5	NUT, 1 M5	
91-8-4	0A1503006	1	+ナベザクミ5X30A	SCREW, PAN (P WASHER) M5X30A	
91-8-5	0A1501406	1	+ナベザクミ5X14A	SCREW, PAN (P WASHER) M5X14A	
91-9	S02782001	1	スプールネジセット3	SPOOL SCREW SET 3	
91-9-1	150179002	3	スプールジクB	SPOOL SHAFT (B)	
91-9-2	028050246	3	バネザガネ2-5	WASHER, SPRING 2-5	
91-9-3	021500106	5	1シユナツト5	NUT, 1 M5	
91-9-4	0A1503006	1	+ナベザクミ5X30A	SCREW, PAN (P WASHER) M5X30A	
91-9-5	0A1501406	1	+ナベザクミ5X14A	SCREW, PAN (P WASHER) M5X14A	
91-10	150180001	5	ウケザラ	SPOOL STAND BASE	
91-11	150182000	5	スプールマット	SPOOL MAT	
91-12	126863001	5	スプールクツシヨン	SPOOL CUSHION	
91-13	S02784009	1	ホルダーササエAセット	HOLDER SUPPORT (A) SET	
91-13-1	150188009	1	スプールホルダーササエA	SPOOL HOLDER SUPPORT (A)	
91-13-2	062501006	1	ナベコ5X10	SCREW, PAN M5X10	
91-13-3	021500106	1	1シユナツト5	NUT, 1 M5	
91-13-4	031452206	1	マルモク45X22	WOOD SCREW, ROUND M4.5X22	
91-14	S02786002	1	スレツドハンガークミ2	THREAD HANGER ASSY 2	
91-15	S02788009	1	スレツドハンガークミ3	THREAD HANGER ASSY 3	
91-16	150145009	1	イトアンナイホルダークミ	THREAD GUIDE HOLDER ASSY	
91-16-1	150185009	1	イトアンナイホルダー	THREAD GUIDE HOLDER	
91-16-2	0A1503006	1	+ナベザクミ5X30A	SCREW, PAN (P WASHER) M5X30A	
91-16-3	021500106	1	1シユナツト5	NUT, 1 M5	
91-17	142999101	1	イトアンナイ5	THREAD GUIDE 5	
91-18	S04109001	1	イトアンナイササエボウ	THREAD GUIDE SUPPORT BAR	
91-19	138843001	1	ササエボウツギテ	JOINT	
91-20	014060632	2	アナトメ6X6クボミ	SET SCREW, SOCKET (CP) M6X6	

索引/INDEX/VERZEICHIS/
INDEX/INDICE

CODE	REF.NO.	Page
J00102001	Q - 1	58
J00103001	Q - 1-9	58
S00075000	A4 - 14-1-3	12
S00313009	A1 - 31	2
S00356001	K1 - 51	38
	K2 - 51	42
S00383001	K1 - 52	38
	K2 - 52	42
S00480000	X1 - 20-1	78
	X1 - 20-2	78
S00879001	C1 - 25	18
S01295001	A2 - 139	6
	S1 - 1-27	60
	S2 - 1-27	64
S01297001	X2 - 50-9	80
S01374001	C2 - 40-1-4	20
	C2 - 40-2-4	20
	C2 - 40-3-4	20
	C2 - 40-6-4	22
S01522000	V - 7-1-2	72
	S2 - 66-2	66
	X3 - 70-11-2	82
S01542000	S2 - 66-3	66
	X2 - 40-21	80
S01561000	X2 - 40-2	80
S01694001	S1 - 1-25	60
	S2 - 1-25	64
S01696001	M - 96	50
	T - 14	68
S01696002	A1 - 89	4
S01943001	Z1 - 5	84
S02556001	M - 33	48
S02592009	U - 1-1-5	70
S02606000	A1 - 5	2
S02745001	U - 1-1-3-4	70
	S1 - 45	62
	S2 - 45	66
S02747101	Z1 - 116	84
S02775001	Z3 - 90-2	88
	Z4 - 91-2	90
S02778002	Z3 - 90-6	88
	Z4 - 91-6	90
S02779009	Z4 - 91-7	90
S02780001	Z3 - 90-7	88
	Z4 - 91-8	90
S02782001	Z4 - 91-9	90
S02784009	Z4 - 91-13	90
S02786002	Z3 - 90-11	88
	Z4 - 91-14	90
S02788009	Z4 - 91-15	90
S02874001	D - 4-3	22
S03421001	J - 13	36
S04109001	Z3 - 90-14	88
	Z4 - 91-18	90
S04159000	S1 - 44	62
	S1 - 54	62
	S2 - 44	66
	S2 - 54	66
S04896000	V - 3-1	72
	X1 - 2-1	78
S04910000	X3 - 70-11-3	82
S05246000	E2 - 102	28
S05981000	U - 1-1-3-8	70
S05982000	U - 1-1-3-9	70
S06701000	Z1 - 19	84

CODE	REF.NO.	Page
S06704001	Z1 - 45	84
S07027001	X1 - 16-6	78
S07317001	A4 - 14-1-6	12
	A4 - 14-2-6	12
S07350001	T - 2	68
S08138000	X2 - 43	80
S08238000	K1 - 107	40
	K2 - 107	44
S08627001	A1 - 2-1	2
S08628000	A1 - 3	2
S08629009	A1 - 12-1	2
S08630201	A1 - 16-1	2
S08631000	A1 - 17	2
S08632009	A1 - 23-1	2
S08682001	B - 3	14
S08683000	B - 4	14
S08684101	B - 6	14
S08685001	B - 6-1	14
S08686101	B - 6-2	14
S08688001	B - 9	14
S08692101	B - 17	14
S08693001	B - 17-1	14
S08694001	B - 17-2	14
S08696000	B - 24	14
S08697000	B - 25	14
S08698001	B - 26	14
S08715010	B - 31	16
	B - 31	16
	Z1 - 1	84
S08758009	D - 1	22
S08760009	D - 1-1	22
S08761100	D - 3	22
S08769001	C1 - 6	18
S08770000	C1 - 12	18
	K1 - 49	38
	K2 - 49	42
S08771001	C1 - 14	18
S08774001	C1 - 18	18
S08775000	C1 - 28	18
S08776001	C1 - 30	18
S08777001	C1 - 31	18
	K1 - 114	40
	K2 - 114	44
S08782101	C2 - 40-1-1	20
	C2 - 40-2-1	20
	C2 - 40-3-1	20
S08783101	C2 - 40-1-3	20
	C2 - 40-2-3	20
	C2 - 40-3-3	20
	C2 - 40-6-3	22
S08784001	C2 - 40-1-6	20
	C2 - 40-2-6	20
	C2 - 40-3-6	20
	C2 - 40-6-6	22
S08785001	C2 - 40-1-8	20
	C2 - 40-2-8	20
	C2 - 40-3-8	20
S08806101	C2 - 40-4-2	20
	C2 - 40-5-2	22
S08807101	C2 - 40-4-4	20
	C2 - 40-5-4	22
S08808001	C2 - 40-4-7	20
	C2 - 40-5-7	22
S08809001	C2 - 40-4-9	20
	C2 - 40-5-9	22

CODE	REF.NO.	Page
S08810001	C2 - 40-4-10	20
	C2 - 40-5-10	22
S08812001	C2 - 40-4-14	20
	C2 - 40-5-16	22
S08889101	F - 1	30
S08890001	F - 1-1	30
S08892001	F - 7	30
S08923101	J - 1	36
S08925000	J - 1-2	36
S08926101	J - 4	36
S08927001	J - 10	36
S08928001	J - 15	36
S08931001	J - 19	36
S08932000	J - 20	36
S08933001	J - 24	36
S08943000	H - 10	34
S08944001	H - 11	34
S08945001	H - 14	34
S08946000	H - 16	34
S08947001	H - 17	34
S08948001	H - 20	34
S08956000	H - 44	34
S08957001	H - 45	34
S08961101	K1 - 1	38
	K2 - 1	42
S08962109	K1 - 6	38
	K2 - 6	42
S08963001	K1 - 10	38
	K2 - 10	42
S08969101	K1 - 40	38
	K2 - 40	42
S08970001	K1 - 91	38
	K1 - 126	40
	K2 - 43	42
	K2 - 91	44
	K2 - 126	44
S08971201	K1 - 45	38
	K2 - 45	42
S08973101	K1 - 45-2	38
	K2 - 45-2	42
S08976001	K1 - 50	38
	K2 - 50	42
S08977001	K1 - 54	38
	K2 - 54	42
S08978001	K1 - 57	38
	K2 - 57	42
S08979001	K2 - 60	42
S08980001	K2 - 61	42
S08981001	K1 - 68	38
	K2 - 68	42
S08982001	K1 - 70	38
	K2 - 70	42
S08983001	K1 - 72	38
	K2 - 72	42
S08984001	Z1 - 64	84
S08985001	K2 - 79	42
S08986001	K2 - 81	44
S08987001	K2 - 82	44
S08988001	K2 - 86	44
S09001101	Z2 - 43	86
	Z2 - 43	86
S09002009	Z1 - 48	84
S09021000	Z2 - 84	86
S09039001	M - 36-2	48
S09043000	N1 - 19	52

CODE	REF.NO.	Page
S09043000	S1 -22	60
	S2 -22	64
S09120001	B -17-3	14
S09121001	B -44	14
	B -44	16
	N2 -143	54
S09124001	N2 -104	54
S09637001	U -1-1-12	70
S10243000	R -29	58
	X2 -44-1	80
	X2 -44-2	80
S10656001	J -1-1	36
S10657001	K1 -45-1	38
	K2 -45-1	42
S10696027	A1 -114	4
S10696028	A1 -114	4
S10696029	A1 -114	4
S10696030	A1 -114	4
S10696031	A1 -114	4
S10696032	A1 -114	4
S10696033	A1 -114	4
S10696034	A1 -114	4
S10696035	A1 -114	4
S10696036	A1 -114	4
S10696037	A1 -114	4
S10696038	A1 -114	4
S10696039	A1 -114	4
S11624000	N1 -57	52
S12696001	N1 -28	52
	N2 -131	54
S12703001	A2 -2-2	6
	A3 -2-2	8
	A4 -2-2	10
	A4 -2-2	10
S12718000	F -15	30
	E1 -91	26
S12724001	B -8	14
S12725101	B -11-2	16
S12806001	F -9-1	30
S12806002	F -9-2	30
S12806003	F -9-3	30
S12821001	M -1-4	48
S12827000	E1 -95	26
S12846001	H -24	34
S12858000	M -46-1	50
S12900001	M -36-5	48
S12913201	M -1-1	48
S12915001	G -27-1-3	32
	M -1-2	48
S12916001	M -1-3	48
S12918000	M -14	48
S12919001	M -16	48
S12920001	M -18	48
S12921001	M -19	48
S12922001	M -20	48
S12923001	M -22	48
S12924001	M -26	48
S12933001	M -32	48
S12934101	M -36	48
S12936001	M -37	48
S12937101	M -39	48
S12939001	M -43	48
S12942001	M -49	50
S12943001	M -51	50
S12946001	M -59	50
S12987001	H -42	34
S13385001	N2 -105	54
S13414201	M -1	48

CODE	REF.NO.	Page
S13415101	M -36-1	48
S13809001	J -6	36
	N2 -116	54
S14085011	R -25	58
S14145000	X1 -10-2	78
S14621001	B -1-2	14
S14622001	F -1-2	30
S17773001	M -2	48
S20500001	E1 -87-1	26
S20500002	E1 -87-2	26
S20500003	E1 -87-3	26
S20549101	E1 -77	26
S20550002	E1 -78	26
S20560001	E1 -79	26
S20598000	G -2	32
S21352001	V -2-1	72
	X1 -1-1	78
S21353001	V -2-2	72
	X1 -1-2	78
S21356001	X2 -40-1	80
S21357001	X2 -40-6	80
S21358001	X2 -40-8	80
S21359001	X2 -40-11	80
S21360001	X2 -40-12	80
S21361001	X2 -40-13	80
S21362000	X2 -40-14	80
S21378001	X3 -63-12	82
S21829001	C1 -1	18
S21830001	C1 -4	18
S21867001	R -1	58
S21868101	R -3	58
S21871101	R -4	58
S21872101	R -6	58
S21873001	R -8	58
S21874000	R -9	58
S21875001	R -10	58
S21876001	R -12	58
S21877001	R -14	58
S21878001	K1 -11	38
	K2 -11	42
S21879001	K1 -27	38
	K2 -27	42
S21880001	K1 -28	38
	K2 -28	42
S21881001	K1 -29	38
	K2 -29	42
S21882001	K1 -30	38
	K2 -30	42
S21883001	K1 -31	38
	K2 -31	42
S21884001	K1 -142	40
	K2 -142	44
S21885001	K1 -144	40
	K2 -144	44
S21886001	K1 -146	40
	K2 -146	44
S21887001	K1 -147	40
	K2 -147	44
S21888001	K1 -150	40
	K2 -150	44
S21891001	K1 -151	40
	K2 -151	44
S21893001	K1 -153	40
	K2 -153	44
S21894001	K1 -156	40
	K2 -156	44
S21895001	S1 -20	60
S21896001	S1 -20-1	60

CODE	REF.NO.	Page
S21897000	S1 -20-2	60
S21898001	S1 -20-3	60
S21899000	U -1-1-2-2	70
	S1 -20-5	60
S21900001	S1 -20-7	60
	S2 -63	66
S21901001	S1 -21	60
S21902001	S1 -25	62
	S2 -25	64
S21903001	S1 -29	62
	S2 -29	64
S21904101	S1 -32	62
	S2 -32	64
S21906001	S1 -9	60
	S2 -9	64
S21907001	S1 -11	60
	S2 -11	64
S21933001	S1 -33	62
	S2 -33	66
S21934001	S1 -35	62
	S2 -35	66
S21935001	S1 -37	62
	S2 -37	66
S21937001	S1 -41	62
	S2 -41	66
S21938001	S1 -43	62
	S2 -43	66
S21940101	S1 -51-1	62
	S2 -51-1	66
S21941001	Q -3	58
S21942001	Z2 -26-2	86
S21943001	Z1 -110	84
S21946101	U -1-1	70
S21947001	U -1-1-1	70
S21948101	U -1-1-2	70
S21949101	U -1-1-2-1	70
S21950009	U -1-1-3	70
S21951001	U -1-1-3-1	70
S21952101	U -1-2	70
S21953001	U -1-1-11	70
S21954001	U -1-1-15	70
S21955001	U -1-1-16	70
S21960001	A4 -16-3	12
S21963001	K2 -140	44
S21964001	T -1	68
S21965001	T -4	68
S21966001	T -6	68
S21967001	T -8	68
S21968001	T -9	68
S21969001	T -13	68
S21970001	T -15	68
S21971001	T -17	68
S21972001	T -19	68
S21974001	T -21	68
S21976001	T -22	68
S21977001	T -24	68
S21978000	T -28	68
S21979001	T -29	68
S21980001	T -30	68
S21981001	T -32	68
S21982101	T -34	68
S21983001	T -35	68
S21984001	T -36	68
S21985001	T -37	68
S21986001	T -39	68
S21987001	T -41	68
S21988001	T -43	68
S23323001	N1 -15	52

CODE	REF.NO.	Page
S23647000	X2 - 40-22	80
S23660000	R - 24	58
S23671000	A3 - 163-2	8
	A4 - 240-2	10
S24021000	R - 28	58
S25818002	E1 - 80	26
S28007001	A1 - 35	2
S28008000	A1 - 36	2
S28011000	A1 - 40	2
S28012001	A1 - 43	2
S28014000	A1 - 45	2
S28021001	A2 - 52-3	6
S28022001	A4 - 52-4	10
S28024001	A2 - 52-6	6
	A2 - 52-6	6
	A2 - 52-6	6
	A4 - 52-6	10
S28027001	A1 - 55-1	2
S28029001	A4 - 55-3	10
S28030001	A2 - 55-4	6
	A4 - 55-4	10
S28031001	A1 - 56	2
S28032001	A1 - 59	2
S28033000	A1 - 64	2
S28034101	A1 - 72	2
S28035001	A1 - 74	2
S28036001	A1 - 78	2
S28037000	A1 - 79	2
S28038001	A1 - 81-1	2
S28039000	A1 - 82	2
S28040000	A1 - 83	2
S28041001	A1 - 88-1	4
S28042001	A2 - 88-2	6
	A4 - 88-2	10
S28043009	A1 - 90	4
S28044009	A1 - 91	4
S28045000	A1 - 100	4
S28046000	A1 - 101	4
S28052001	A2 - 128	6
	A2 - 128	6
S28053001	A2 - 129	6
	A2 - 129	6
S28054001	A2 - 132	6
	A2 - 200	6
S28055001	A2 - 133	6
	A2 - 201	6
S28056001	A2 - 135	6
	A2 - 135	6
	A2 - 203	6
S28059101	A2 - 206	6
	A4 - 226	10
S28060001	A2 - 68-3	6
S28061001	N2 - 142	54
S28063001	B - 35-1	14
S28064001	B - 35-1-1	14
	B - 35-2-1	16
	B - 35-3-1	16
	B - 35-4-1	16
	B - 35-5-1	16
S28065001	B - 35-2	16
S28066001	B - 35-3	16
S28068001	B - 11-1	14
S28069009	B - 1	14
S28070009	B - 1-1	14
S28075001	B - 38	14
S28087001	B - 48	14
S28088001	B - 50	14
S28090001	B - 52	14

CODE	REF.NO.	Page
S28090001	B - 62	14
S28091001	B - 54	14
S28092001	B - 56	14
S28094001	B - 58	14
S28095001	B - 60	14
S28096000	B - 51	14
	B - 61	14
S28097001	B - 64	14
S28099000	D - 4-1	22
S28100000	D - 4-2	22
S28101000	D - 6	22
S28104000	D - 9	22
S28105001	C2 - 36-1	22
	Z2 - 62-1	86
S28106001	C2 - 36-2	22
S28107101	C2 - 36-3	20
	Z2 - 62-2	86
S28108101	C2 - 36-4	20
S28131001	C2 - 40-6-1	22
S28156001	A1 - 85	4
S28157000	A1 - 58	2
S28159001	E1 - 1	24
S28160001	E1 - 1-1	24
S28161001	E1 - 1-1-3	24
S28163001	E1 - 1-1-1	24
S28164001	E1 - 1-1-2	24
S28165001	G - 27-2	32
	E1 - 1-2	24
S28166001	E1 - 4	24
S28167001	E1 - 7	24
S28168001	E1 - 8	24
S28170001	E1 - 9	24
S28171001	E1 - 11	24
S28172001	E1 - 13	24
S28173000	E1 - 14	24
S28174001	E1 - 16	24
S28175000	E1 - 17	24
S28176001	E1 - 18	24
S28177001	E1 - 20	24
S28179001	E1 - 22	24
S28180001	E1 - 23	24
S28181001	E1 - 26	24
S28182001	E1 - 28	24
S28183001	E1 - 30	24
S28184000	G - 5	32
	E1 - 31	24
S28185000	E1 - 32	24
S28186001	E1 - 35	24
	E1 - 40	24
	E1 - 50-2	24
	E1 - 85-3	26
S28188001	E1 - 39	24
S28189001	E1 - 42	24
S28190001	E1 - 44	24
S28191001	E1 - 45	24
S28192001	E1 - 46	24
S28193001	E1 - 47	24
	E1 - 98	26
S28194001	E1 - 49	24
S28198001	E1 - 50-1	24
S28199001	E1 - 50-4	26
S28200001	E1 - 55	26
S28201001	E1 - 56	26
S28202001	E1 - 57	26
S28203001	E1 - 60	26
S28204001	E1 - 62	26
S28205001	E1 - 64	26
S28206000	E1 - 65	26

CODE	REF.NO.	Page
S28207000	E1 - 66	26
S28208001	E1 - 70	26
S28209001	E1 - 72	26
S28210001	E1 - 74	26
S28211001	E1 - 85	26
S28212001	E1 - 85-1	26
S28213001	E1 - 85-2	26
S28214001	E1 - 88-1	26
S28215001	E1 - 88-2	26
S28216000	E1 - 92	26
S28217000	E1 - 93	26
S28218001	E1 - 94	26
S28219001	E2 - 100-1	28
S28220001	E2 - 100-1-1	28
S28221000	E2 - 100-1-2	28
S28222000	E2 - 100-1-3	28
S28223000	E2 - 101	28
S28224000	E2 - 103	28
S28225001	E2 - 100-2	28
S28226001	E2 - 105	28
S28227001	E2 - 107	28
S28228001	E2 - 109	28
S28229000	E2 - 111	28
S28231000	E2 - 120	28
	N2 - 112	54
S28232001	E2 - 113	28
	E2 - 122	28
S28233001	E2 - 114	28
S28234000	E2 - 118	28
S28235000	E2 - 119	28
S28236001	E2 - 127	28
S28248001	E1 - 75	26
S28249001	E1 - 19	24
S28250001	M - 6	48
S28252000	M - 6-2	48
S28253001	M - 11	48
S28254001	M - 28	48
S28256001	M - 29	48
S28260001	M - 44	48
S28261001	M - 46	50
S28263001	M - 52	50
S28264001	M - 53	50
S28265001	M - 66	50
S28266001	M - 68	50
S28267001	M - 70	50
S28268001	M - 71	50
S28269001	M - 75	50
S28270001	M - 80	50
S28271001	M - 83-1	50
S28272001	M - 83-2	50
S28273001	M - 90	50
S28274001	M - 93	50
S28275001	M - 95	50
S28276000	M - 100-1	50
S28277000	M - 100-2	50
S28278000	M - 100-3	50
S28279000	M - 102-1	50
S28282000	M - 102-2	50
S28283000	M - 102-3	50
S28287001	N1 - 1	52
S28289000	N1 - 1-1	52
S28290000	N1 - 1-2	52
S28292001	N1 - 6	52
S28293000	N1 - 7	52
S28295001	N1 - 10	52
S28297001	N1 - 12	52
S28298001	N1 - 14	52
S28299000	N1 - 16	52

CODE	REF.NO.	Page
S28300001	N1 - 18	52
S28302001	N1 - 20	52
S28305001	N1 - 22	52
S28306001	N1 - 27	52
	N2 - 130	54
S28307001	N1 - 29	52
S28308001	N1 - 31	52
S28310001	N1 - 35	52
S28311001	N1 - 36	52
	N2 - 135	54
S28312001	N1 - 38	52
S28313001	N1 - 39	52
S28314000	N1 - 41	52
S28315001	N1 - 42	52
S28316001	N1 - 44	52
S28317001	N1 - 47	52
S28318001	N1 - 48	52
	S1 - 1-33	60
	S2 - 1-33	64
S28319001	N1 - 50	52
S28320001	N1 - 51	52
S28321001	N1 - 53	52
S28322001	N1 - 55	52
S28323001	N1 - 58	52
S28324001	N1 - 60	52
S28332001	M - 72	50
S28333001	M - 61	50
S28334001	M - 41	48
S28336001	N2 - 100	54
S28338000	N2 - 100-1	54
S28340001	N2 - 106	54
S28341000	N2 - 110	54
S28342000	N2 - 111	54
S28343001	N2 - 114	54
S28344001	N2 - 119	54
S28346001	N2 - 121	54
S28348001	N2 - 123	54
S28349001	N2 - 125	54
S28350001	N2 - 132	54
S28352001	N2 - 134	54
S28353001	N2 - 108	54
S28354001	N2 - 139	54
S28357001	X3 - 65	82
S28363001	F - 10	30
S28364001	F - 10-1	30
S28365001	F - 10-2	30
S28367011	F - 21	30
S28367012	F - 21	30
S28368011	F - 22	30
S28368012	F - 22	30
S28372000	F - 13	30
S28373001	F - 16	30
S28374000	F - 18	30
S28375000	F - 19	30
S28376000	F - 20	30
S28377001	G - 4	32
S28381000	G - 33-1	32
S28383001	G - 17	32
S28384001	G - 18	32
S28385000	G - 20	32
S28386001	G - 21	32
S28387001	G - 22	32
S28389001	G - 25	32
S28390001	G - 27-1	32
S28391001	G - 27-1-1	32
S28393001	G - 27-1-2	32
S28394001	G - 30	32
S28396001	G - 36	32

CODE	REF.NO.	Page
S28397101	H - 1	34
S28398001	H - 1-4	34
S28400100	H - 1-6	34
S28401001	H - 4	34
S28403001	H - 32	34
S28405001	H - 27	34
S28406001	H - 35	34
S28409001	H - 37	34
S28411001	H - 40	34
S28415000	H - 52	34
S28416001	H - 54	34
S28417001	K1 - 99	38
	K2 - 99	44
S28420001	K1 - 101	38
	K2 - 101	44
S28421000	K1 - 103	40
	K2 - 103	44
S28422000	K1 - 104	40
	K2 - 104	44
S28423000	K1 - 105	40
	K2 - 105	44
S28424001	K1 - 106	40
	K2 - 106	44
S28425001	K1 - 108	40
	K2 - 108	44
S28427001	K1 - 109	40
	K2 - 109	44
S28431001	K1 - 113-1	40
	K2 - 113-1	44
S28434001	K1 - 113-2	40
	K2 - 113-2	44
S28435001	K1 - 113-5	40
	K2 - 113-5	44
S28436001	K1 - 128	40
	K2 - 128	44
S28437001	K1 - 130	40
	K2 - 130	44
S28438001	K1 - 78	38
	K2 - 78	42
S28441001	Z2 - 37	86
S28442001	Z2 - 38	86
S28444001	Z2 - 53	86
S28445001	Z2 - 56	86
S28468001	V - 2	72
	X1 - 1	78
S28469000	V - 3-2	72
	X1 - 2-2	78
S28470000	V - 3-3	72
	X1 - 2-3	78
S28471000	V - 3-4	72
	X1 - 2-4	78
S28472000	V - 3-5	72
	X1 - 2-5	78
S28473001	X2 - 40	80
S28474000	X2 - 42	80
S28476000	X2 - 53	80
S28477000	X2 - 53-1	80
S28478000	X2 - 53-2	80
S28479000	X2 - 56	80
S28480000	X2 - 56-1	80
S28481000	X2 - 56-2	80
S28490001	S1 - 1-1	60
	S2 - 1-1	64
S28492001	A1 - 52-1	2
S28493001	A3 - 52-2	8
S28494001	A3 - 52-5	8
S28495001	A3 - 55-2	8
S28496001	A3 - 81-2	8

CODE	REF.NO.	Page
S28497001	A3 - 88-3	8
S28500001	A2 - 140	6
	A2 - 140	6
	A3 - 140	8
S28502001	A3 - 149	8
S28503000	A3 - 152	8
	A4 - 228	10
S28504000	A3 - 153	8
	A4 - 229	10
S28505001	A3 - 156	8
S28506001	A3 - 159	8
S28507000	A3 - 162	8
S28508000	A3 - 163	8
	A4 - 240	10
S28509000	A3 - 163-1	8
	A4 - 240-1	10
S28510001	A3 - 165	8
S28512001	B - 35-4	16
S28513001	B - 35-5	16
S28515001	A3 - 175	8
S28516001	A3 - 176	8
S28517001	A3 - 179	8
S28518001	A3 - 181	8
S28519000	A3 - 184	8
S28521001	A4 - 68-4	10
S28523001	A2 - 208	6
	A4 - 208	10
S28525000	A4 - 223	10
S28526001	A4 - 231	10
S28527001	A4 - 235	10
S28528001	A4 - 236	10
S28529001	A4 - 238	10
S28532001	A4 - 241	10
S28533001	A4 - 242	10
S28558001	C2 - 40-4-1	20
S28560001	C2 - 40-4-12	20
S28567001	C2 - 40-5-1	22
S28569001	C2 - 40-5-12	22
S28570001	C2 - 40-5-14	22
S28591001	J - 26	36
S28596001	V - 1-1	72
S28597000	V - 1-3	72
S28598000	V - 1-3-1	72
S28599000	V - 1-3-2	72
	S2 - 61-2	66
S28600001	V - 1-5	72
S28601001	L - 1	46
S28602001	L - 1-1-1	46
S28604001	L - 2-3	46
S28606001	L - 1-3	46
S28609001	L - 1	46
S28610001	L - 1-1-2	46
S28614001	L - 1	46
S28615001	L - 1-1-3	46
S28619001	L - 2	46
S28620001	L - 2-1-1	46
S28622001	L - 2	46
S28623001	L - 2-1-2	46
S28625001	L - 2	46
S28626001	L - 2-1-3	46
S28629001	P - 1	56
S28630001	P - 3	56
S28631001	P - 5	56
S28632001	P - 6	56
S28633001	P - 8	56
S28634001	P - 10	56
S28635001	P - 12	56
S28636001	P - 15	56

CODE	REF.NO.	Page
S28637000	P -17	56
S28638001	P -20	56
S28639001	P -23	56
S28640000	P -24	56
S28641001	P -26	56
S28642001	P -28	56
S28643001	P -30	56
S28644001	S1 -1-2	60
	S2 -1-2	64
S28645001	S1 -1-3	60
	S1 -1-9	60
	S1 -1-16	60
	S1 -7	60
	S2 -1-3	64
	S2 -1-9	64
	S2 -1-16	64
	S2 -7	64
S28646001	S1 -1-4	60
	S1 -1-7	60
	S1 -1-10	60
	S1 -1-17	60
	S1 -8	60
	S2 -1-4	64
	S2 -1-7	64
	S2 -1-10	64
	S2 -1-17	64
	S2 -8	64
S28647001	S1 -1-5	60
	S2 -1-5	64
S28648001	S1 -1-6	60
	S2 -1-6	64
S28649000	S1 -1-8	60
	S2 -1-8	64
S28650101	S1 -1-11	60
	S2 -1-11	64
S28651001	S1 -1-13	60
	S2 -1-13	64
S28652001	S1 -1-14	60
	S2 -1-14	64
S28653000	S1 -1-15	60
	S2 -1-15	64
S28654001	S1 -1-18	60
	S2 -1-18	64
S28655001	S1 -1-19	60
	S2 -1-19	64
S28656101	S1 -1-20	60
	S2 -1-20	64
S28657001	S1 -1-21	60
	S2 -1-21	64
S28658001	S1 -1-22	60
	S2 -1-22	64
S28659101	S1 -1-23	60
	S2 -1-23	64
S28660001	S1 -1-24	60
	S2 -1-24	64
S28661001	S1 -1-26	60
	S2 -1-26	64
S28662001	S1 -1-28	60
	S2 -1-28	64
S28663001	S1 -1-31	60
	S2 -1-31	64
S28665001	S1 -2	60
	S2 -2	64
S28666001	S1 -4	60
	S2 -4	64
S28667001	S1 -6	60
	S2 -6	64
S28668001	S1 -12	60

CODE	REF.NO.	Page
S28668001	S2 -12	64
S28669001	S1 -51-2	62
	S2 -51-2	66
S28670000	S2 -61	66
S28671000	S2 -61-1	66
S28674000	S2 -65	66
S28675000	S2 -66	66
S28676000	S2 -66-1	66
S28677000	S2 -68	66
S28678001	S2 -60	66
S28680001	V -7-1-1	72
S28681001	V -1	72
S28682001	V -7	72
S28683001	V -7-1	72
S28685000	V -7-3	72
	X1 -14	78
S28686000	V -7-4	72
S28687001	W1 -1	74
S28688001	W1 -1-1	74
S28689001	W1 -1-1-1	74
	W2 -2-1-1	76
S28690001	W1 -1-1-3	74
	W2 -2-1-3	76
S28691000	W1 -1-1-4	74
	W2 -2-1-4	76
S28692001	W1 -1-1-5	74
	W2 -2-1-5	76
S28693000	W1 -1-1-7	74
	W1 -1-2-5	74
	W1 -1-3-6	74
	W2 -2-1-7	76
	W2 -2-2-5	76
	W2 -2-3-6	76
S28694001	W1 -1-1-9	74
S28695000	W1 -1-1-10	74
S28696001	W1 -1-1-11	74
S28697001	W1 -1-2	74
	W2 -2-2	76
S28698001	W1 -1-2-1	74
	W2 -2-2-1	76
S28699001	W1 -1-2-4	74
	W2 -2-2-4	76
S28700001	W1 -1-2-8-1	74
	W1 -1-3-8-1	74
	W2 -2-2-8-1	76
	W2 -2-3-8-1	76
S28701000	W1 -1-2-8-3	74
	W1 -1-3-8-3	74
	W2 -2-2-8-3	76
S28702001	W1 -1-3-1	74
	W2 -2-3-1	76
S28703001	W1 -1-3-4	74
	W2 -2-3-4	76
S28704001	W1 -1-3-5	74
	W2 -2-3-5	76
S28705001	W1 -1-3	74
S28706001	W2 -2	76
S28707001	W2 -2-1	76
S28708001	W2 -2-1-9	76
S28709001	W2 -2-1-10	76
S28710001	W2 -2-1-12	76
S28711000	W2 -2-1-13	76
S28712001	W2 -2-1-14	76
S28714001	W2 -2-3	76
S28716000	W2 -2-3-8-3	76
S28720009	X1 -16	78
S28721009	X1 -16-11	78
S28722009	X1 -16-11-1	78

CODE	REF.NO.	Page
S28726001	X1 -10	78
S28727000	X1 -10-1	78
S28730000	X1 -15	78
S28731001	X3 -70	82
S28732001	X3 -70-1	82
S28733001	X3 -70-5	82
S28734001	X3 -70-7	82
S28735000	X3 -70-9	82
S28736000	X3 -70-9-1	82
S28737001	X3 -70-10	82
S28738000	X3 -70-11	82
S28739000	X3 -70-11-1	82
S28740000	X3 -70-13	82
S28741000	X3 -70-14	82
S28742000	N1 -63	52
	N2 -140	54
	X1 -10-3	78
	X3 -70-9-2	82
S28744000	R -26	58
S28745001	X2 -57	80
S28746001	W1 -1-2-8	74
	W1 -1-3-8	74
	W2 -2-2-8	76
S28747001	W2 -2-3-8	76
S28750001	D -4	22
S28759001	S1 -39	62
	S2 -39	66
S28760001	S1 -47	62
	S2 -47	66
S28765001	A1 -47-1	2
S28766001	A2 -47-2	6
	A2 -47-2	6
	A2 -47-2	6
	A2 -47-2	6
	A3 -47-2	8
	A4 -47-2	10
	A4 -47-2	10
S28790001	E1 -50	24
S28793001	E2 -100	28
S28795001	G -27	32
S28796001	K1 -113	40
	K2 -113	44
S28797101	S1 -1	60
	S2 -1	64
S28798001	C1 -32-1	18
S28800001	C1 -32-2	18
S28801001	C1 -32-3	18
S28802001	A4 -14-1	12
S28803001	A4 -14-1-1	12
	A4 -14-2-1	12
S28804001	A4 -14-1-2	12
	A4 -14-2-2	12
S28805001	A4 -14-2	12
S28806000	A4 -14-2-3	12
S28807001	A4 -12-2	12
S28809001	A4 -23-2	12
S28810001	A4 -16-2	12
S28811001	A4 -16-4	12
S28812000	A1 -75	2
S28814001	A1 -68-1	2
S28815001	A3 -68-2	8
S28818001	A3 -171-2	8
S28819001	A3 -171-1	8
S28820000	A1 -49	2
	N2 -100-2	54
S28821000	U -1-1-2-5	70
S28822001	A2 -138	6
S28823001	G -12	32

CODE	REF.NO.	Page
S28824001	G - 12-1	32
S28825001	G - 12-2	32
S28826001	G - 14	32
S28828001	G - 15	32
S28830001	Z2 - 27	86
S28831001	A2 - 211	6
	A4 - 211	10
S28842001	G - 6	32
S28843001	E2 - 116	28
	E2 - 123	28
S28844001	E1 - 37	24
S28845000	E1 - 90	26
S28846001	H - 29	34
S28848000	G - 9	32
S28849000	Z2 - 2	86
S28850001	A1 - 105	4
S28851000	H - 47	34
S28852000	H - 49	34
S28866001	A3 - 145	8
S28867001	A4 - 220	10
S28869000	G - 26	32
S28885001	G - 33	32
S28887001	Z1 - 118	84
S28888001	Z1 - 118-1	84
S28889001	Z1 - 118-2	84
S28890001	Z1 - 118-3	84
S28891001	Z1 - 118-3-1	84
S28892001	Z1 - 118-3-2	84
S28893001	Z1 - 118-3-3	84
S28894001	Z1 - 118-3-4	84
S28895001	Z1 - 118-3-5	84
S28897001	R - 20	58
S28898001	R - 21	58
S28899001	R - 23	58
S28902000	R - 27	58
S29854009	Z3 - 90	88
S29855009	Z4 - 91	90
S30086001	B - 17-4	14
S30564000	K1 - 17	38
	K2 - 17	42
S30565001	K1 - 26	38
	K2 - 26	42
S30565002	K1 - 23	38
	K2 - 23	42
S30565003	K1 - 21	38
	K2 - 21	42
	K2 - 25	42
S30565004	K1 - 22	38
	K2 - 22	42
S31012001	C1 - 19	18
S31013001	C1 - 20	18
0A1501406	Z3 - 90-7-5	88
	Z4 - 91-8-5	90
	Z4 - 91-9-5	90
0A1503006	Z3 - 90-7-4	88
	Z3 - 90-12-2	88
	Z4 - 91-8-4	90
	Z4 - 91-9-4	90
	Z4 - 91-16-2	90
003400804	L - 1-2	46
	L - 2-2	46
007402516	X2 - 40-3	80
014060622	A1 - 32	2
	A1 - 97	4
014060632	Z3 - 90-16	88
	Z4 - 91-20	90
014680422	B - 49	14
	B - 53	14

CODE	REF.NO.	Page
014680422	B - 55	14
	B - 56-1	14
	B - 59	14
	B - 63	14
	B - 65	14
	G - 19	32
	G - 37	32
	J - 23	36
	M - 13	48
	M - 67	50
	M - 94	50
	P - 9	56
	P - 16	56
	P - 29	56
	T - 5	68
	T - 12	68
	T - 20	68
	A3 - 169	8
	E1 - 5	24
	E1 - 10	24
	E1 - 36	24
	E1 - 41	24
	E1 - 50-3	24
	E1 - 85-4	26
	K1 - 5	38
	K1 - 71	38
	K1 - 110	40
	K1 - 148	40
	K1 - 152	40
	K2 - 5	42
	K2 - 71	42
	K2 - 110	44
	K2 - 148	44
	K2 - 152	44
	N1 - 13	52
	N1 - 34	52
	N1 - 40	52
	N1 - 43	52
	N1 - 45	52
	N1 - 56	52
	N2 - 109	54
	N2 - 138	54
	W1 - 1-1-12	74
014680622	G - 27-1-1-1	32
	H - 15	34
	J - 1-1-1	36
	Q - 4	58
	A1 - 63	2
	E1 - 24	24
014710522	U - 1-1-17	70
	N1 - 30	52
	N2 - 133	54
014760622	B - 16	14
	B - 19-1	14
	M - 1-1-4	48
	M - 50	50
	P - 4	56
	P - 27	56
	C1 - 26	18
	E1 - 69	26
	E1 - 97	26
	S1 - 27	62
	S2 - 27	64
014770622	B - 2	14
	B - 5	14
	B - 7	14
	B - 14	14
	F - 3	30

CODE	REF.NO.	Page
014770622	F - 11	30
	G - 1	32
	J - 13-1	36
	J - 16	36
	M - 3	48
	M - 54	50
	E1 - 1-1-3-1	24
	E1 - 34	24
	E1 - 50-5	26
	E1 - 59	26
	E1 - 86	26
	K1 - 45-1-1	38
	K1 - 100	38
	K1 - 102	40
	K1 - 108-1	40
	K2 - 45-1-1	42
	K2 - 100	44
	K2 - 102	44
	K2 - 108-1	44
	S1 - 31	62
	S2 - 31	64
	W1 - 1-1-14	74
	W2 - 2-1-11	76
	W2 - 2-1-15	76
	W2 - 2-1-17	76
014780622	F - 2	30
	G - 23	32
	E2 - 108	28
	X3 - 63-6	82
017681012	M - 69	50
	M - 82	50
017711612	C1 - 15	18
017771412	G - 8	32
017781012	X3 - 63-4	82
	X3 - 63-10	82
	X3 - 63-13	82
018060822	H - 28	34
	A1 - 13	2
	W1 - 1-1-16	74
	W1 - 1-2-8-6	74
	W1 - 1-3-8-6	74
	W2 - 2-1-19	76
	W2 - 2-2-8-6	76
	W2 - 2-3-8-6	76
018061022	M - 91	50
	E1 - 73	26
018061222	V - 1-2	72
018061622	H - 2	34
	M - 17	48
	M - 47	50
018061631	U - 1-1-7	70
018062022	G - 10	32
	S1 - 23	62
	S2 - 23	64
018063022	M - 7	48
018081622	A1 - 102	4
	E1 - 37-1	24
018082022	W1 - 1-1-6	74
	W1 - 1-2-6	74
	W2 - 2-1-6	76
	W2 - 2-2-6	76
018082522	W1 - 1-1-8	74
	W2 - 2-1-8	76
018300622	T - 31	68
018400832	U - 1-1-4	70
018401422	F - 22-1	30
	F - 22-1	30
	T - 25	68

CODE	REF.NO.	Page
018401422	K1 -45-2-1	38
	K2 -45-2-1	42
	N1 -32	52
018501022	T -16	68
	A4 -239	10
	N1 -2	52
018501222	S1 -24	62
018501422	N2 -102	54
018502522	N1 -3	52
018503022	N2 -101	54
018505022	V -1-4	72
018680522	P -11	56
	P -14	56
018680822	T -18	68
	A2 -141	6
	A2 -141	6
	A2 -209	6
	A3 -141	8
	A4 -209	10
	X3 -70-6	82
018681022	B -36-1	14
	B -36-2	16
	R -5	58
	R -22	58
	N2 -115	54
	X3 -70-8	82
018681232	A1 -48	2
018771432	F -6	30
	G -13	32
	J -5	36
	M -2-1	48
	C1 -10	18
	E1 -43	24
	E1 -49-1	24
	E1 -63	26
	K1 -47	38
	K1 -55	38
	K2 -47	42
	K2 -55	42
021060106	Z2 -41	86
021060306	X2 -40-10	80
	X2 -40-19	80
021080106	U -1-3	70
	Z2 -29	86
021080302	U -1-1-2-3	70
	U -1-1-10	70
	U -1-7	70
	V -1-6	72
	S1 -20-4	60
	S2 -64	66
021400102	T -27	68
021400106	X2 -40-5	80
	Z1 -23	84
021400164	X1 -16-10	78
021400206	X2 -40-7	80
021500106	A3 -160	8
	Z1 -115	84
	Z3 -90-4-2	88
	Z3 -90-7-3	88
	Z3 -90-12-3	88
	Z4 -91-4-2	90
	Z4 -91-8-3	90
	Z4 -91-9-3	90
	Z4 -91-13-3	90
	Z4 -91-16-3	90
021660102	C2 -40-4-8	20
	C2 -40-5-8	22
021710202	P -2	56

CODE	REF.NO.	Page
021710202	P -22	56
025030232	A4 -14-1-5	12
	A4 -14-2-5	12
025030335	Q -1-4	58
025040233	X1 -16-8	78
025040236	A3 -164	8
	X2 -40-4	80
	X2 -40-16	80
025050132	A1 -61	2
025050232	A4 -14-1-8	12
	A4 -14-2-8	12
025050236	A3 -161	8
	Z1 -113	84
025060236	Z2 -39	86
025060332	W1 -1-2-8-5	74
	W1 -1-3-8-5	74
	W2 -2-1-18	76
	W2 -2-2-8-5	76
	W2 -2-3-8-5	76
025080232	U -1-1-2-4	70
	S1 -20-6	60
	W1 -1-2-7	74
	W1 -1-3-7	74
	W2 -2-2-7	76
	W2 -2-3-7	76
025080236	U -1-5	70
	Z2 -31	86
025350332	H -1-2	34
	P -18	56
025630132	S1 -1-30	60
	S2 -1-30	64
025680133	A3 -178	8
025710232	P -21	56
	P -25	56
025750132	Z2 -55	86
028040243	X1 -16-9	78
028050246	A4 -14-1-7	12
	A4 -14-2-7	12
	Z1 -114	84
	Z3 -90-7-2	88
	Z4 -91-8-2	90
	Z4 -91-9-2	90
028060242	Z2 -40	86
028080242	U -1-4	70
	Z2 -30	86
031311302	X1 -11	78
	X1 -22	78
	X2 -46	80
	X2 -58	80
031452206	W1 -1-1-2	74
	W1 -1-2-2	74
	W1 -1-3-2	74
	W2 -2-1-2	76
	W2 -2-2-2	76
	W2 -2-3-2	76
	Z4 -91-13-4	90
032422505	V -7-2	72
	X3 -64	82
	X3 -70-12	82
034422503	X1 -17	78
047140850	N1 -31-1	52
	N2 -132-1	54
047200642	D -1-2	22
	K1 -125	40
	K2 -125	44
047400842	M -65	50
	E1 -49-2	24
047402042	G -22-1	32

CODE	REF.NO.	Page
047501242	E1 -71	26
048015346	C2 -40-4-5	20
	C2 -40-5-5	22
048020342	C2 -40-1-5	20
	C2 -40-2-5	20
	C2 -40-3-5	20
	C2 -40-6-5	22
048030342	K1 -145	40
	K2 -145	44
	N1 -52	52
048040342	U -1-1-13	70
	A1 -60	2
048050342	T -3	68
048080342	W1 -1-2-8-2	74
	W1 -1-3-8-2	74
	W2 -2-2-8-2	76
	W2 -2-3-8-2	76
048090142	M -30	48
048090342	K1 -111	40
	K2 -111	44
048180242	H -50	34
048240242	H -48	34
048470242	F -17	30
060400616	X2 -40-15	80
060630412	C2 -40-4-11	20
	C2 -40-5-11	22
	E2 -121	28
	N2 -113	54
060670512	R -15	58
	A4 -14-1-10	12
	A4 -14-2-10	12
	X2 -50-6	80
060670812	B -39	14
060680512	T -42	68
	K1 -143	40
	K2 -141	44
	K2 -143	44
	S1 -49	62
	S2 -49	66
060680712	A3 -154	8
	A4 -15	12
	A4 -24-2	12
	A4 -230	10
	C1 -3	18
	K1 -41	38
	K2 -41	42
	K2 -62	42
	K2 -80	44
	N2 -141	54
	S1 -3	60
	S1 -34	62
	S1 -38	62
	S1 -40	62
	S2 -3	64
	S2 -34	66
	S2 -38	66
	S2 -40	66
	Z2 -44	86
	Z2 -44	86
060681212	A1 -44	2
062020805	S1 -36	62
	S2 -36	66
062300612	N1 -23	52
	N2 -124	54
062301616	S1 -42	62
	S2 -42	66
062303012	S2 -67	66
062350616	E1 -81	26

CODE	REF.NO.	Page
062401006	X1 -16-7	78
062401406	Z1 -24	84
062501006	Z1 -112	84
	Z4 -91-13-2	90
062501406	Z3 -90-4-1	88
	Z4 -91-4-1	90
062630412	R -13	58
	T -33	68
	C2 -37	20
	C2 -37	20
	C2 -37	22
	C2 -37	22
062630612	M -1-5	48
062660512	T -38	68
	A4 -14-1-4	12
	A4 -14-2-4	12
	C2 -40-1-7	20
	C2 -40-2-7	20
	C2 -40-3-7	20
	C2 -40-6-7	22
062670412	L -1-3-1	46
	L -2-3-1	46
	A3 -145-1	8
	A4 -220-1	10
	C2 -40-5-15	22
	S1 -5	60
	S2 -5	64
062670512	K1 -154	40
	K2 -154	44
	N1 -61	52
062670612	B -22	14
	G -27-3	32
	H -6	34
	H -8	34
	H -12	34
	H -18	34
	H -21	34
	H -36	34
	P -19	56
	U -1-1-3-3	70
	U -1-1-6	70
	U -1-1-9	70
	E1 -1-3	24
	K1 -69	38
	K1 -113-3	40
	K1 -117	40
	K2 -69	42
	K2 -113-3	44
	K2 -117	44
	N2 -126	54
062670812	H -1-3	34
	R -11	58
	C1 -33	18
	E1 -76	26
062671012	D -7	22
	G -33-2	32
	H -1-8	34
	U -1-1-3-2	70
062680512	T -7	68
	A2 -207	6
	A4 -221	10
	A4 -224	10
	A4 -227	10
	S1 -26	62
	S2 -26	64
062680612	F -4	30
	M -45	48
	T -22	68

CODE	REF.NO.	Page
062680612	A2 -204	6
	A4 -237	10
	K1 -92	38
	K1 -127	40
	K1 -129	40
	K2 -44	42
	K2 -92	44
	K2 -127	44
	K2 -129	44
062680663	U -1-1-3-5	70
	S1 -46	62
	S2 -46	66
062680712	R -17	58
	R -30	58
	T -45	68
	A1 -86	4
	N1 -49	52
	S1 -53	62
	S2 -53	66
	X1 -21	78
	X2 -45	80
062680812	D -5	22
	H -41	34
	H -43	34
	A1 -37-1	2
	A1 -76	2
	A3 -150	8
	A3 -157	8
	A3 -177	8
	A3 -180	8
	A4 -232	10
	K1 -2	38
	K1 -74	38
	K2 -2	42
	K2 -74	42
062681012	J -27	36
	A1 -4	2
	A2 -37-2	6
	A3 -37-2	8
	A4 -20	12
	A4 -37-2	10
	A4 -37-2	10
	K1 -7	38
	K1 -58	38
	K2 -7	42
	K2 -58	42
062681212	K1 -32	38
	K2 -32	42
	N1 -21	52
	N2 -122	54
062681412	J -25	36
	C1 -29	18
062681612	A1 -18-1	2
	A1 -80	2
	A4 -18-2	12
	N1 -54	52
062682012	M -55	50
062710612	L -1-4	46
	L -2-4	46
	A1 -73	2
	A3 -146	8
062710712	N1 -59	52
062710812	Z2 -57	86
	Z2 -59	86
062711012	B -10	14
062711212	L -1-5	46
	L -2-5	46
	Q -2	58

CODE	REF.NO.	Page
062711212	A2 -136	6
	A2 -136	6
	A3 -147	8
062711612	A3 -166	8
076000600	Q -1-3	58
076000800	W1 -1-2-8-4	74
	W1 -1-3-8-4	74
	W2 -2-2-8-4	76
	W2 -2-3-8-4	76
081007070	E1 -25	24
081007670	J -21	36
081008070	K1 -112	40
	K2 -112	44
081012070	G -24	32
	E1 -15	24
081014670	A1 -6	2
081044070	H -46	34
081046870	B -12	14
100064005	B -17-4-1	14
	G -14-1	32
	G -15-1	32
	C2 -40-1-2	20
	C2 -40-2-2	20
	C2 -40-3-2	20
	C2 -40-4-3	20
	C2 -40-5-3	22
	C2 -40-6-2	22
100105005	A2 -212	6
	A4 -212	10
	E1 -29	24
	S1 -1-29	60
	S2 -1-29	64
100257010	B -45	16
100360003	A2 -134	6
	A2 -202	6
100463001	X1 -16-3	78
	X3 -63-8	82
100526003	M -26-1	48
100644005	R -2	58
	E2 -110	28
	K1 -157	40
	K2 -157	44
100645003	T -26	68
	A1 -77	2
	A1 -87	4
	A2 -142	6
	A2 -142	6
	A2 -205	6
	A2 -210	6
	A3 -142	8
	A3 -151	8
	A3 -158	8
	A3 -183	8
	A4 -210	10
	A4 -222	10
	A4 -225	10
	K1 -59	38
100666002	Z2 -54	86
101118001	V -4	72
	X1 -3	78
	X2 -55	80
101482001	J -3	36
101572101	Z1 -3	84
101671002	S1 -1-32	60
	S2 -1-32	64
102023005	N1 -4	52
102424004	A1 -57	2
	Z1 -49	84

CODE	REF.NO.	Page
102538002	M - 101	50
102630001	B - 23	14
	U - 1-1-14	70
102716004	N1 - 26	52
	N2 - 129	54
102836004	T - 40	68
102843004	A1 - 24-1	2
103810002	M - 74	50
	M - 76	50
	K1 - 115	40
	K1 - 158	40
	K2 - 115	44
	K2 - 158	44
104449009	A1 - 27	2
	A1 - 92	4
104450109	A1 - 28	2
	A1 - 94	4
104464001	B - 13	14
104521002	S1 - 30	62
	S2 - 30	64
104830101	A1 - 99	4
105130001	A4 - 234	10
105161003	D - 8	22
105161004	L - 1-3-2	46
	L - 2-3-2	46
	M - 1-1-3	48
	A3 - 145-2	8
	A4 - 220-2	10
	E1 - 82	26
	K1 - 113-4	40
	K2 - 113-4	44
105234003	M - 56	50
	M - 79	50
	A1 - 71	2
	A3 - 182	8
105237002	R - 7	58
105248003	N1 - 62	52
	X2 - 50-8	80
105288001	K1 - 113-6	40
	K2 - 113-6	44
105343001	Z1 - 13	84
105812003	M - 35	48
106128004	M - 38	48
	M - 42	48
106129001	A4 - 14-1-9	12
	A4 - 14-2-9	12
106568003	S1 - 1-12	60
	S2 - 1-12	64
106588003	M - 64	50
106629002	E1 - 27	24
	S1 - 1-34	60
	S2 - 1-34	64
107153001	B - 18	14
	M - 34	48
107231002	A1 - 69	2
107272002	M - 31	48
	A1 - 42	2
	A3 - 172	8
107407003	M - 84	50
	A1 - 41	2
107453001	M - 24	48
107779001	Z1 - 14	84
107780001	Z2 - 16	86
108549001	E1 - 67	26
108960002	N1 - 5	52
109203001	A1 - 104	4
109239001	M - 60	50
109763002	T - 11	68

CODE	REF.NO.	Page
110072001	A2 - 130	6
	A2 - 130	6
110087001	X1 - 16-5	78
110140001	M - 25	48
	M - 27	48
	S1 - 10	60
	S2 - 10	64
110161006	G - 32	32
	J - 8	36
	C1 - 16	18
	N2 - 118	54
110167001	M - 57	50
	V - 1-7	72
110168001	M - 58	50
	V - 1-8	72
110197001	J - 22	36
110215002	L - 1-1-2-2	46
	L - 1-1-3-2	46
	L - 2-1-2-2	46
	L - 2-1-3-2	46
110243001	N1 - 25	52
	N2 - 128	54
110641002	A1 - 103	4
110793001	C1 - 7	18
110813001	K1 - 12	38
	K2 - 12	42
110832009	K1 - 14	38
	K2 - 14	42
111032001	X2 - 50-7	80
112299001	Z1 - 66	84
112300001	Z1 - 65	84
112301001	Z1 - 67	84
112351001	H - 22	34
112359001	H - 25	34
112364001	H - 30	34
	H - 33	34
	H - 38	34
112467002	H - 1-1-1	34
112700001	M - 63	50
112743001	H - 5	34
112751003	E2 - 106	28
113431002	A2 - 137	6
	A2 - 137	6
	Z2 - 58	86
113644001	M - 1-1-1	48
114967001	X1 - 16-4	78
115157001	Z2 - 11	86
115559002	X3 - 70-4	82
116016001	Z1 - 25	84
116662003	Z2 - 60	86
117466000	Z1 - 18	84
117608001	M - 8	48
	M - 48	50
	M - 92	50
117671002	E1 - 33	24
	E1 - 58	26
117934009	A1 - 22	2
118064001	Z2 - 9	86
118735002	T - 10	68
	W1 - 1-1-15	74
118770001	H - 9	34
118837001	Z1 - 21	84
118853001	B - 15	14
	M - 36-1-1	48
	S1 - 28	62
	S2 - 28	64
119712001	X2 - 40-20	80
121007001	M - 40	48

CODE	REF.NO.	Page
122991001	Z1 - 91	84
126863001	Z3 - 90-10	88
	Z4 - 91-12	90
138843001	Z3 - 90-15	88
	Z4 - 91-19	90
140066009	A1 - 93	4
140092001	M - 12	48
140407001	C1 - 22	18
140418000	E1 - 6	24
140430001	N1 - 11	52
140678000	V - 2-3	72
	X1 - 1-3	78
140759000	Z1 - 46	84
141208001	C1 - 23	18
141542001	P - 7	56
141544001	L - 1-1-1-1	46
	L - 1-1-2-1	46
	L - 1-1-3-1	46
	L - 2-1-1-1	46
	L - 2-1-2-1	46
	L - 2-1-3-1	46
	C2 - 40-4-13	20
141728001	C1 - 21	18
142026003	X1 - 16-1	78
142027001	X1 - 16-2	78
142268001	U - 1-1-8	70
142274001	D - 4-4	22
142274009	A1 - 95	4
	A1 - 98	4
142359001	H - 3	34
	H - 51	34
142721001	Z1 - 7	84
142998101	Z3 - 90-13	88
142999101	Z4 - 91-17	90
143325001	C1 - 5	18
143359001	X2 - 54	80
143522000	U - 1-1-3-6	70
143566001	Z1 - 15	84
143602001	K1 - 42	38
	K2 - 42	42
144075001	M - 1-1-2	48
144103009	K1 - 15	38
	K2 - 15	42
144104001	K1 - 18	38
	K2 - 18	42
144110001	K1 - 19	38
	K2 - 19	42
144224001	Z1 - 47	84
144504001	K2 - 83	44
144505000	K2 - 84	44
144526001	K1 - 149	40
	K1 - 155	40
	K2 - 149	44
	K2 - 155	44
144619000	H - 1-1	34
144622001	H - 1-5	34
144625009	X2 - 50-4	80
144875001	H - 1-9	34
144876001	H - 1-10	34
145277105	Z1 - 20	84
145446001	K1 - 16	38
	K2 - 16	42
145472001	C1 - 24	18
145480101	X3 - 70-2	82
145688000	B - 21	14
145737001	H - 19	34
146046000	X1 - 16-11-2	78
146049001	Z2 - 6	86











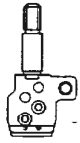
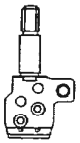
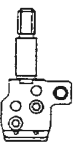



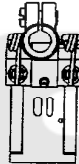
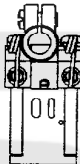

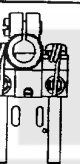

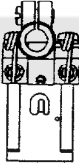
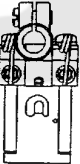
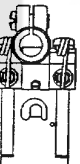
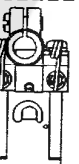
CODE	REF.NO.	Page
146194000	X1 - 16-11-3	78
146254001	U - 1-6	70
146354001	A4 - 233	10
	W1 - 1-2-3	74
	W1 - 1-3-3	74
	W2 - 2-2-3	76
	W2 - 2-3-3	76
146427001	B - 30-1	16
	B - 30-1	16
	P - 31	56
	C2 - 40-4-6	20
	C2 - 40-5-6	22
	K2 - 87	44
146522101	C1 - 2	18
146547000	J - 17	36
146598001	A1 - 62	2
146695001	X2 - 40-9	80
	X2 - 40-18	80
146700001	Z2 - 4	86
146924000	K1 - 113-1-1	40
	K2 - 113-1-1	44
147246101	X2 - 50	80
147247009	X2 - 50-1	80
147248009	X2 - 50-2	80
147251009	X2 - 50-3	80
147252000	X2 - 50-5	80
147402001	P - 13	56
	A3 - 168	8
147527000	H - 1-7	34
147528100	H - 1-12	34
147529000	H - 1-13	34
147893009	Z1 - 22	84
147919002	Z2 - 42	86
	Z2 - 42	86
148084001	A1 - 38	2
148120000	M - 6-1	48
148144001	N1 - 46	52
148186001	E2 - 115	28
148196000	J - 11	36
148197000	J - 12	36
148294001	M - 21	48
	A1 - 84	4
148559100	E1 - 84	26
148797001	X3 - 63-5	82
148798009	X3 - 63-7	82
148834001	J - 15-1	36
	J - 18	36
	A3 - 185	8
	N1 - 24	52
	N2 - 127	54
148847001	G - 31	32
	J - 7	36
	L - 1-6	46
	L - 2-6	46
	M - 81	50
	A3 - 148	8
	N2 - 117	54
148857001	E1 - 12	24
	E1 - 48	24
	E1 - 99	26
149247001	Z2 - 26-1	86
149288003	K1 - 131	40
	K2 - 131	44
149547000	R - 16	58
	T - 44	68
149604001	N1 - 20-1	52
	N2 - 121-1	54
149799000	X1 - 16-12	78





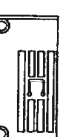
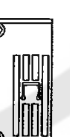

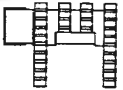



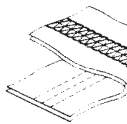

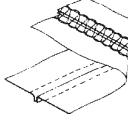
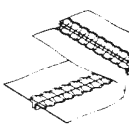
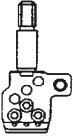

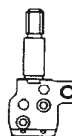
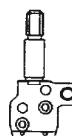
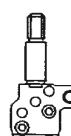

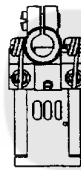
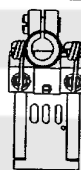
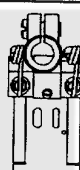

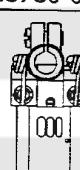
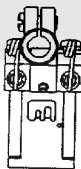
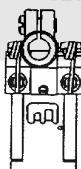
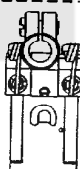
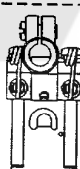
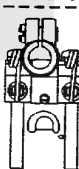
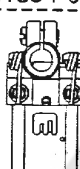
CODE	REF.NO.	Page
150106003	Z3 - 90-4	88
	Z4 - 91-4	90
150145009	Z3 - 90-12	88
	Z4 - 91-16	90
150172003	Z3 - 90-3	88
	Z4 - 91-3	90
150174000	Z3 - 90-5	88
	Z4 - 91-5	90
150179002	Z3 - 90-7-1	88
	Z4 - 91-8-1	90
	Z4 - 91-9-1	90
150180001	Z3 - 90-8	88
	Z4 - 91-10	90
150182000	Z3 - 90-9	88
	Z4 - 91-11	90
150185009	Z3 - 90-12-1	88
	Z4 - 91-16-1	90
150188009	Z4 - 91-13-1	90
150191002	Z3 - 90-2-2	88
	Z4 - 91-2-2	90
150206002	Z3 - 90-2-1	88
	Z4 - 91-2-1	90
150604101	M - 36-3	48
150605001	M - 36-4	48
150644009	K2 - 3	42
150645009	K1 - 4	38
	K2 - 4	42
151090001	G - 7	32
151429001	H - 7	34
151439002	X3 - 70-3	82
151987001	M - 73	50
152718001	B - 19-2	16
	N1 - 17	52
	N2 - 107	54
153195001	A3 - 167	8
153208002	B - 37-1	16
	B - 37-2	16
	N1 - 37	52
	N2 - 136	54
153269001	X1 - 10-4	78
153353001	N1 - 33	52
	N2 - 137	54
153675001	F - 14	30
	E1 - 89	26
	F - 3	30
153734001	F - 3	30
153788001	W1 - 1-1-13	74
	W2 - 2-1-16	76
154125001	Z2 - 10	86
154149001	M - 78	50
154574001	A1 - 70	2
154596000	C1 - 27	18
154599000	A3 - 170	8
154841009	A1 - 29	2
	A1 - 33	4
154886001	F - 5	30
154956001	C1 - 9	18
154957001	C1 - 11	18
155103001	C2 - 40-5-13	22
155157001	E2 - 117	28
	E2 - 124	28
155162001	K1 - 56	38
	K2 - 56	42
155167001	E1 - 61	26
155196309	X3 - 63	82
155197101	X3 - 63-1	82
155198101	X3 - 63-2	82
155199101	X3 - 63-3	82
155201101	X3 - 63-9	82







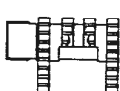



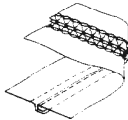
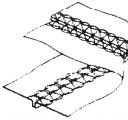
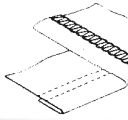
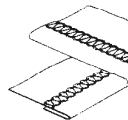
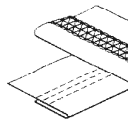
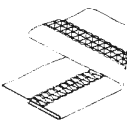

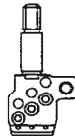
CODE	REF.NO.	Page
155202001	X3 - 63-11	82
155220000	C1 - 8	18
	K1 - 48	38
	K2 - 48	42
155318001	K1 - 116	40
	K2 - 116	44
155510001	K2 - 85	44
155539000	C1 - 13	18
	K1 - 53	38
	K2 - 53	42
155559001	G - 11	32
156112003	Z3 - 90-1	88
	Z4 - 91-1	90
156217009	A1 - 96	4
156265001	M - 23	48
156309001	Z1 - 12	84
156887001	A1 - 34	4
156937001	A4 - 19	12
157840000	H - 13	34
159093009	M - 62	50
159150009	M - 15	48
	A1 - 7	2
	A2 - 30	6
	A3 - 30	8
	A4 - 30	10
	A4 - 30	10
159238001	M - 77	50
159476000	H - 23	34
	H - 26	34
	H - 31	34
	H - 34	34
	H - 39	34
159491001	E1 - 68	26
	E1 - 96	26
159574101	K1 - 13	38
	K2 - 13	42
159874000	V - 7-1-3	72
	S2 - 66-4	66
	X3 - 70-11-4	82
159908001	S1 - 13	60
	S2 - 13	64
181225001	X2 - 40-17	80
183796201	U - 1	70
200190001	X1 - 18	78
211528001	Q - 1-8	58
211964001	Z2 - 28	86
215082001	Q - 1-13	58
215083001	Q - 1-5	58
216410003	Q - 1-15	58
216870001	Q - 1-12	58
219558000	Q - 1-6-2	58
220077001	U - 1-1-3-7	70
226391001	Q - 1-16	58
230100001	Q - 1-10	58
233193001	S1 - 50	62
	S2 - 50	66
234141001	Q - 1-1	58
234143001	Q - 1-2	58
234144001	Q - 1-6	58
234145001	Q - 1-6-1	58
234146001	Q - 1-7	58
234153001	Q - 1-11	58
234154002	Q - 1-14	58
340400001	H - 53	34
415006002	S2 - 62	66
525907000	S1 - 52	62
	S2 - 52	66
575456001	D - 2	22

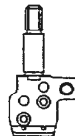
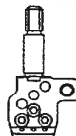

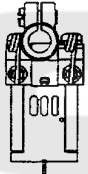
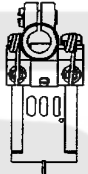
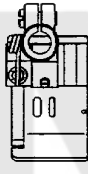
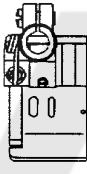
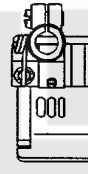
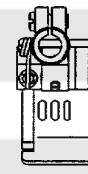
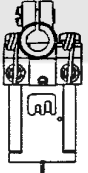
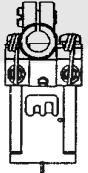
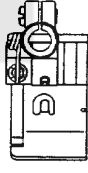
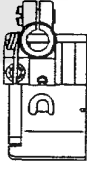
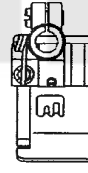
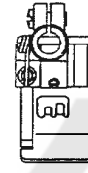
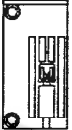
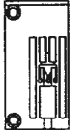



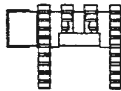
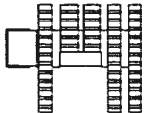
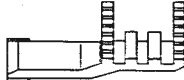



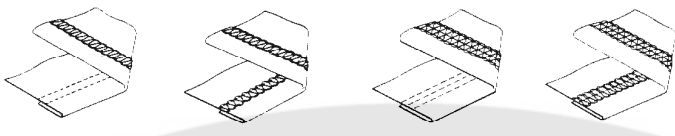
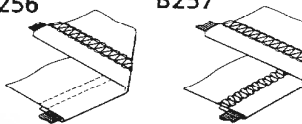

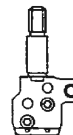



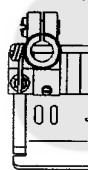



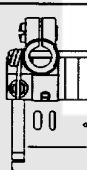

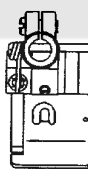

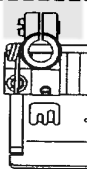
ゲージ部品一覧表 / GAUGE PARTS LIST / LEHRENLISTE /
LISTE DES PIÈCES D'ECARTEMENT / LISTA DE PIEZAS DE CALIBRADORES

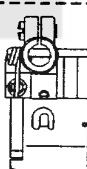





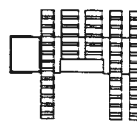
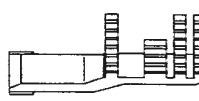

1/8

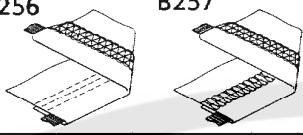

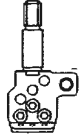
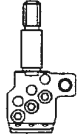
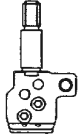
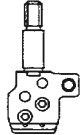

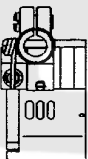
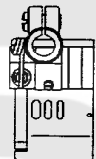
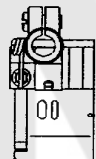
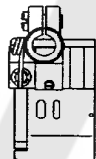
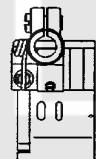
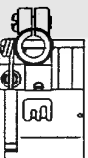
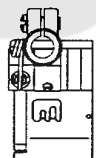
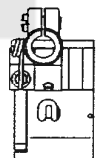
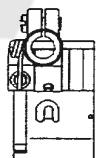
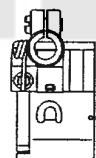
機種 Model	B256 B257	B256 B257	B256 B257	B256 B257	B256 B257	B256 B257
仕様 Specifications	011-1	011-2	011-3	011-4	011-5	011-6
仕様ラベル Label	S08678-001	S08678-002	S08678-003	S08678-004	S08678-005	S08678-006
用途 Application	地縫用 Plain stitching 					
針数(本) No. of needles	2	2	2	2	2	3
針幅(mm) Needle spacing	3.2	4.0	4.8	5.6	6.4	4.8
針止×組 Needle clamp assy	 S28770-001	 S28772-001	 S28774-001	 S28776-001	 S28778-001	 S28780-001
押工組 Presser foot assy (B256)	 S21832-001	 S21834-001	 S21836-001	 S21838-001	 S21840-001	 S21842-001
押工組 Presser foot assy (B257)	 S08779-201	 S08786-201	 S08788-201	 S08790-201	 S08792-201	 S08794-201
針板 Needle plate	 S08717-001	 S08718-001	 S08719-001	 S08720-001	 S08721-001	 S08722-001
主送り歯 Main feed dog	 S28237-001					
差動送り歯 Differential feed dog	 S28242-001					

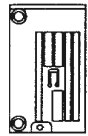

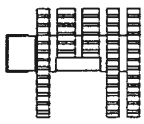
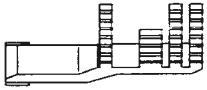

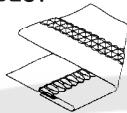
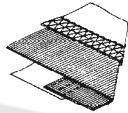
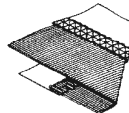
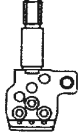
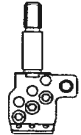
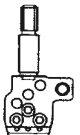
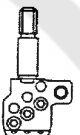
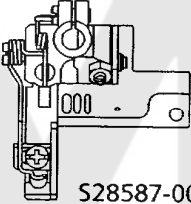
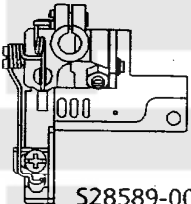
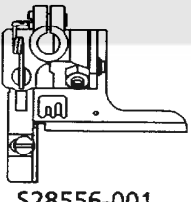
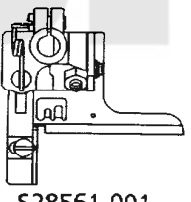
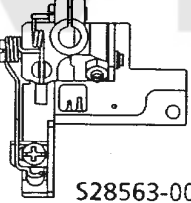
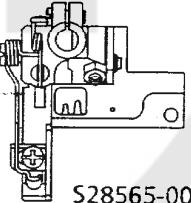
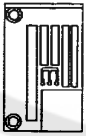
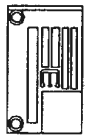
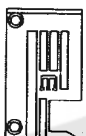
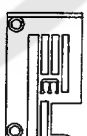

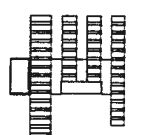
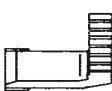



機種 Model	B256 B257	B256 B257	B256 B257	B256 B257	B256 B257	B256 B257
仕様 Specifications	011-7	011-8	033-3	033-4	033-5	033-6
仕様ラベル Label	S08678-007	S08678-008	S08678-064	S08678-065	S08678-066	S08678-067
用途 Application	地縫用 / Plain stitching B256  B257 		カバーリング用 Covering B256  B257 			
針数 (本) No. of needles	3	3	2	2	2	3
針幅 (mm) Needle spacing	5.6	6.4	4.8	5.6	6.4	4.8
針止×組 Needle clamp assy	 S28782-001	 S28784-001	 S28774-001	 S28776-001	 S28778-001	 S28780-001
押工組 Presser foot assy (B256)	 S21844-001	 S21846-001	 S21848-001	 S21850-001	 S21582-001	 S21854-001
押工組 Presser foot assy (B257)	 S08796-201	 S08798-201	 S08828-201	 S08830-201	 S08832-201	 S08834-201
針板 Needle plate	 S08723-001	 S08724-001	 S21823-001	 S21824-001	 S21825-001	 S21826-001
主送り歯 Main feed dog	 S28237-001		 S28239-001			
差動送り歯 Differential feed dog	 S28242-001		 S28244-001			

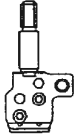
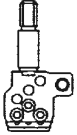
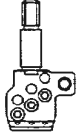



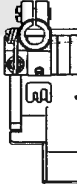
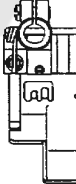

機種 Model	B256 B257	B256 B257	B256 B257	B256 B257	B256 B257	B256 B257
仕様 Specifications	033-7	033-8	051-2	051-3	051-7	051-8
仕様ラベル Label	S08678-068	S08678-069	S08678-057	S08678-058	S08678-062	S08678-063
用途 Application	カバーリング用 / Covering B256  B257 		ヘム縫用 / Hem stitching B256  B257 		B256 	B257 
針数 (本) No. of needles	3	3	2	2	3	3
針幅 (mm) Needle spacing	5.6	6.4	4.0	4.8	5.6	6.4
針止×組 Needle clamp assy	 S28782-001	 S28784-001	 S28772-001	 S28774-001	 S28782-001	 S28784-001
押工組 Presser foot assy (B256)	 S21856-001	 S21858-001	 S28140-101	 S28142-101	 S28144-101	 S28146-101
押工組 Presser foot assy (B257)	 S08836-201	 S08838-201	 S28121-101	 S28123-101	 S28125-101	 S28127-101
針板 Needle plate	 S21827-001	 S21828-001	 S28079-001	 S28080-001	 S28081-001	 S28082-001
主送り歯 Main feed dog	 S28239-001		 S28240-001			
差動送り歯 Differential feed dog	 S28244-001		 S28245-001			

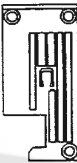
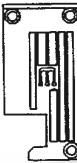
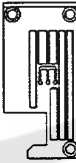
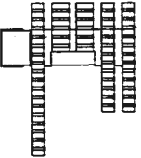
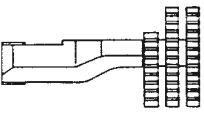
機種 Model	B256 B257	B256 B257	B256 B257	B256 B257	B256 B257	B256 B257
仕様 Specifications	053-2	053-3	053-7	053-8	056-2	056-3
仕様ラベル Label	S08678-090	S08678-091	S08678-095	S08678-096	S08678-070	S08678-071
用途 Application	ヘム縫用 / Hem stitching B256 B257 B256 B257 				ゴム入れヘム縫用 (プーラ装置・定規開閉装置付) Circular hemming (with puller and binder opener) B256 B257 	
針数(本) No. of needles	2	2	3	3	2	2
針幅(mm) Needle spacing	4.0	4.8	5.6	6.4	4.0	4.8
針止×組 Needle clamp assy	 S28772-001	 S28774-001	 S28782-001	 S28784-001	 S28772-001	 S28774-001
押工組 Presser foot assy (B256)	 S28140-101	 S28142-101	 S28144-101	 S28146-101	 S28579-101	 S28581-101
押工組 Presser foot assy (B257)	 S28121-101	 S28123-101	 S28125-101	 S28127-101	 S28548-101	 S28550-101
針板 Needle plate	 S28079-001	 S28080-001	 S28081-001	 S28082-001	 S28542-001	 S28543-001
主送り歯 Main feed dog	 S28240-001					
差動送り歯 Differential feed dog	 S28245-001					

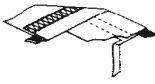
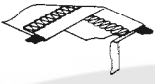
機種 Model	B256 B257	B256 B257	B256 B257	B256 B257	B256 B257	
仕様 Specifications	056-7	056-8	061-1	061-2	061-3	
仕様ラベル Label	S08678-072	S08678-073	S08678-074	S08678-075	S08678-076	
用途 Application	ゴム入れヘム縫用 (プーラ装置・定規開閉装置付) Circular hemming (with puller and binder opener) B256 B257 		平ゴムタタキ縫用(プーラ装置付) Elastic hemming (with puller) B256 B257 			
針数(本) No. of needles	3	3	2	2	2	
針幅(mm) Needle spacing	5.6	6.4	3.2	4.0	4.8	
針止メ組 Needle clamp assy	 S28782-001	 S28784-001	 S28770-001	 S28772-001	 S28774-001	
押工組 Presser foot assy (B256)	 S28583-101	 S28585-101	 S28138-101	 S28140-101	 S28142-101	
押工組 Presser foot assy (B257)	 S28552-101	 S28554-101	 S28118-101	 S28121-101	 S28123-101	
針板 Needle plate	 S28544-001	 S28545-001	 S28078-001	 S28079-001	 S28080-001	
主送り歯 Main feed dog	 S28240-001					
差動送り歯 Differential feed dog	 S28245-001					

機種 Model	B257	B257	B256 B257	B256 B257
仕様 Specifications	0V1-7	0V1-8	0W1-7	0W1-8
仕様ラベル Label	S08678-077	S08678-078	S08678-079	S08678-080
用途 Application	エンドレススパンゴム付用 (プーラ装置・定規開閉装置付) Spun knit elastic loop attaching (with puller and binder opener) B257 		エンドレス平ゴム付用(プーラ装置・右メス装置付) Wide elastic loop attaching (with puller and right knife) B256 B257  	
針数(本) No. of needles	3	3	3	3
針幅(mm) Needle spacing	5.6	6.4	5.6	6.4
針止メ組 Needle clamp assy	 S28782-001	 S28784-001	 S28782-001	 S28784-001
押工組 Presser foot assy (B256)	—		 S28587-001	 S28589-001
押工組 Presser foot assy (B257)	 S28556-001	 S28561-001	 S28563-001	 S28565-001
針板 Needle plate	 S28546-001	 S28547-001	 S08745-001	 S08746-001
主送り歯 Main feed dog	 S28595-001		 S28238-001	
差動送り歯 Differential feed dog	 S28243-001		 S28246-001	

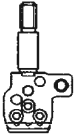
機種 Model	B256 B257	B256 B257	B256 B257	B256 B257		
仕様 Specifications	0X1-2	0X1-3	0X1-7	0X1-8		
仕様ラベル Label	S08678-081	S08678-082	S08678-083	S08678-084		
用途 Application	へム縫用(左メス装置付) / Hem stitching (with left knife) B256 B257 B256 B257 					
針数(本) No. of needles	2	2	3	3		
針幅(mm) Needle spacing	4.0	4.8	5.6	6.4		
針止メ組 Needle clamp assy	 S28772-001	 S28774-001	 S28782-001	 S28784-001		
押工組 Presser foot assy (B256)	 S28148-101	 S28150-101	 S28152-101	 S28154-101		
押工組 Presser foot assy (B257)	 S28129-101	 S28132-101	 S28134-101	 S28136-101		
針板 Needle plate	 S28083-001	 S28084-001	 S28085-001	 S28086-001		
主送り歯 Main feed dog	 S28241-001					
差動送り歯 Differential feed dog	 S28247-001					

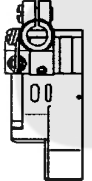
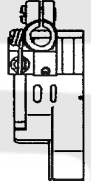
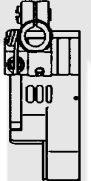
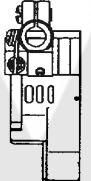
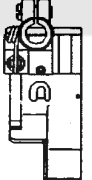
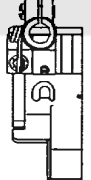
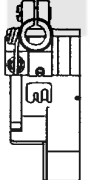
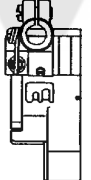
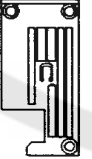
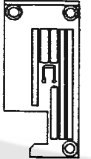
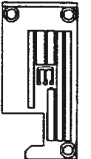
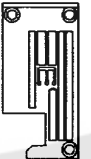
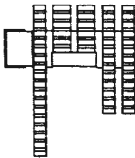
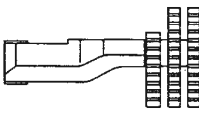
機種 Model	B256 B257	B256 B257	B256 B257	B256 B257		
仕様 Specifications	0X6-2	0X6-3	0X6-7	0X6-8		
仕様ラベル Label	S08678-085	S08678-086	S08678-087	S08678-088		
用途 Application	ゴム入れヘム縫用(プーラ装置・定規開閉装置・左メス装置付) Circular hemming (with puller, binder opener and left knife)					
	B256	B257	B256	B257		
						
針数(本) No. of needles	2	2	3	3		
針幅(mm) Needle spacing	4.0	4.8	5.6	6.4		
針止×組 Needle clamp assy						
	S28772-001	S28774-001	S28782-001	S28784-001		
押工組 Presser foot assy (B256)						
	S28751-101	S28753-101	S28755-101	S28757-101		
押工組 Presser foot assy (B257)						
	S28571-101	S28573-101	S28575-101	S28577-101		
針板 Needle plate						
	S28083-001	S28084-001	S28085-001	S28086-001		
主送り歯 Main feed dog						
	S28241-001					
差動送り歯 Differential feed dog						
	S28247-001					

brother[®]

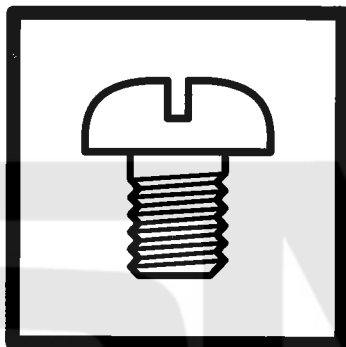

パーツブック
PARTS BOOK
TEILEKATALOG
LIVRE DES PIECES
LIBRO DE REFERENCIA DE PIEZAS

ブラザー工業株式会社

BROTHER INDUSTRIES, LTD.

〒467 名古屋市瑞穂区河岸1丁目1番1号

Printed in Japan/Gedruckt in Japan /Imprimé au Japon/Impreso en Japón

118-256,257
S96256-101
1994, 05