

BAS-341F BAS-342F

プログラム式電子ミシン

PROGRAMMABLE ELECTRONIC PATTERN SEWER WITH CYLINDER BED

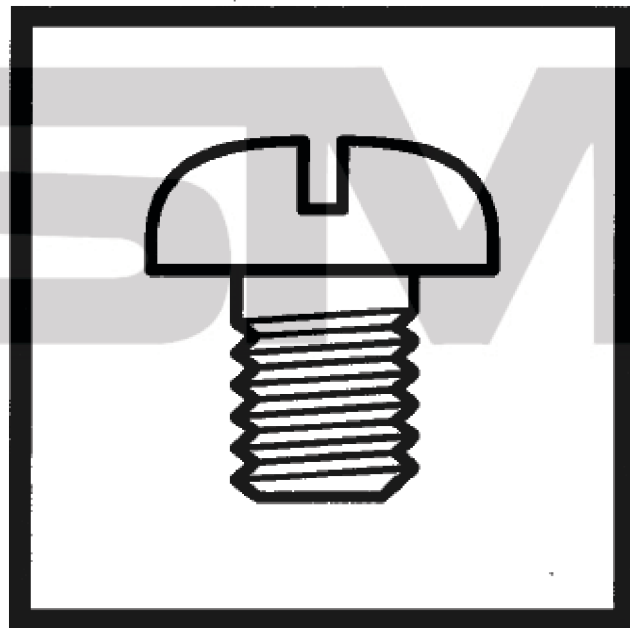

BROTHER INDUSTRIES, LTD.

BAS-34[*]F- [**][*]**

*

- 1 --- BAS-341F
- 2 --- BAS-342F

**

- 01 --- 厚物用 / For Heavy materials
- 02 --- 中厚物用 / For Medium materials

- A1 --- エアー式 UN タイプ押え / UN work clamp (Pneumatic type)
- A2 --- エアー式フラットタイプ押え
/ Flat type work clamp (Pneumatic type)

パーツブックご利用に際して

1. この本は、2002年11月のデータに基づいて作成されたものです。
2. 部品は予告なしに設計変更される場合があります。
3. 組単位で補給する部品は、 破線で示してあります。

目 次

A1. 主体関係 (BAS-341F)	1
A3. 主体関係 (BAS-342F)	7
B. 上軸、針棒関係	13
C1. 送り関係 (BAS-341F)	17
C8. 送り関係 (BAS-342F)	33
D. 押エ上ゲ関係	45
E. 糸切れ感知関係	47
F. 下軸関係	49
G. 給油潤滑関係	53
H. 糸通シ関係	55
J. 糸巻関係	57
K. 糸切り関係	59
L. 糸払い関係	63
M. プログラマー関係 (オプション部品)	63
N. 糸締め関係	65
P. 針位置検出器関係	67
Q. プリント基板関係	67
R. コントロールボックス関係	69
S. 空圧関係	73
T. 電装品関係	77
U. 操作パネル関係	79
V. 踏板関係	81
W. 動力台関係	83
X. 中押エ反転装置関係 (オプション部品)	87
AA. 補助装置関係 (オプション部品)	93
Z. 付属品関係	101
Ga. ゲージ部品一覧表	105
Wa. 警告ラベル	109
索引	110

Notes for using this parts book

1. This book was prepared based on information available in November 2002.
2. Parts are subject to changes in design without prior notice.
3. Parts supplied as complete assemblies are circled by a dotted line .

CONTENTS

A1. Machine body (BAS-341F).....	1
A3. Machine body (BAS-342F).....	7
B. Upper shaft and needle bar mechanism	13
C1. Feed mechanism (BAS-341F).....	17
C8. Feed mechanism (BAS-342F).....	33
D. Work clamp lifter mechanism	45
E. Thread breakage detector mechanism.....	47
F. Lower shaft mechanism.....	49
G. Lubrication.....	53
H. Threading mechanism.....	55
J. Bobbin winder mechanism.....	57
K. Thread trimmer mechanism.....	59
L. Thread wiper mechanism.....	63
M. Programmer (Option parts).....	63
N. Thread nipper mechanism.....	65
P. Synchronizer.....	67
Q. Printed circuit board mechanism.....	67
R. Control box mechanism	69
S. Air pressure mechanism.....	73
T. Power supply equipment mechanism.....	77
U. Operation panel mechanism.....	79
V. Foot switch pedal mechanism.....	81
W. Power table.....	83
X. Inner clamping device (Option parts).....	87
AA. Auxiliary device (Option parts).....	93
Z. Accessories.....	101
Ga. Gauge parts List.....	105
Wa. Warning labels.....	109
INDEX.....	110

A1 . 主体関係 (BAS-341F) / Machine body (BAS-341F)

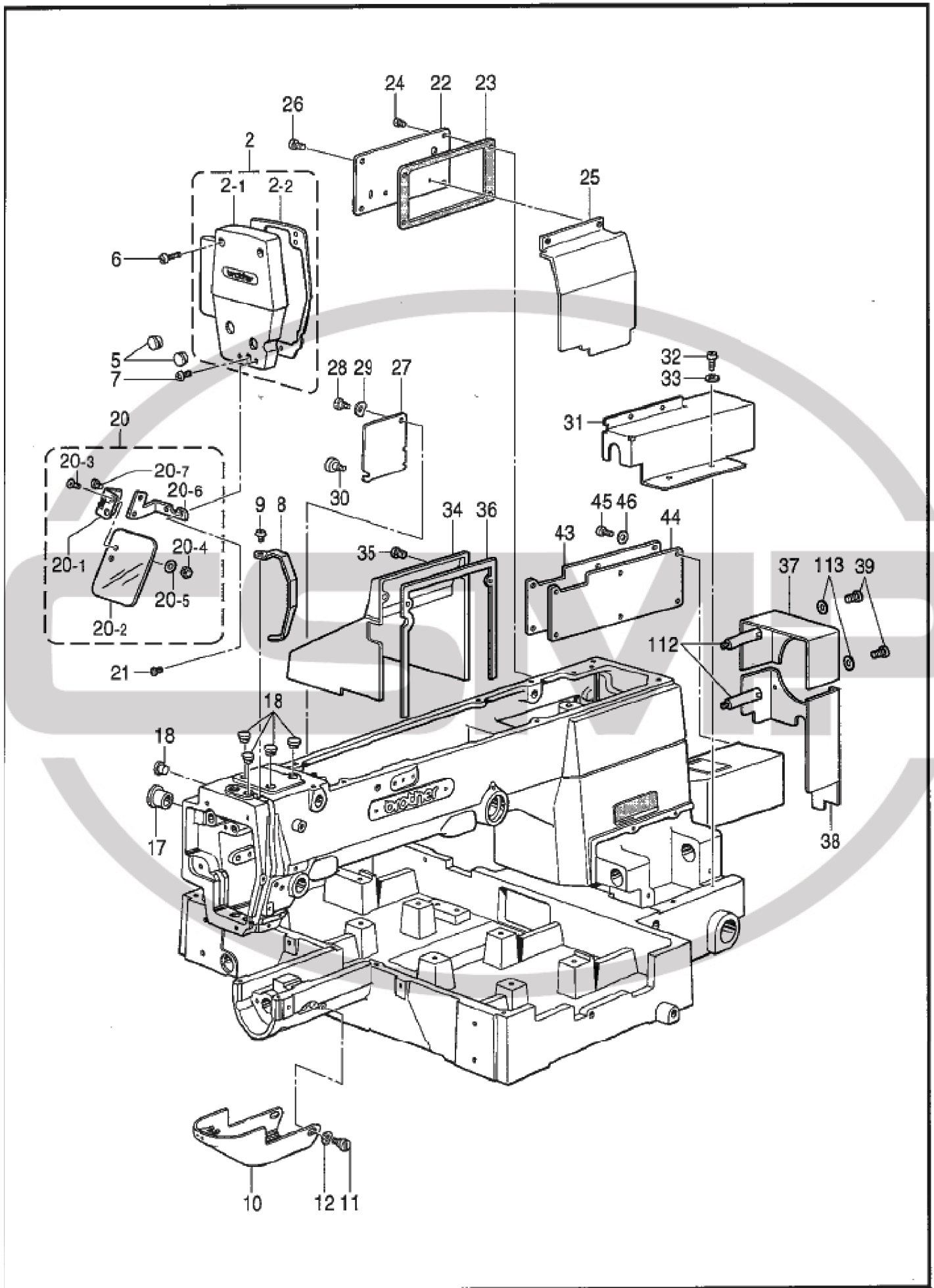

A1. 主体関係 (BAS-341F) / Machine body (BAS-341F)

REF.NO	CODE	QTY	ヒンメイ	NAME OF PARTS	RM
2	S24675001	1	フェイスプレート	FACE PLATE ASSY	
2-1	S25154009	1	フェイスプレート	FACE PLATE	
2-2	S25155100	1	フェイスプレートパッキン	PACKING, F	
5	117934001	2	ゴムキャップ 13.5	RUBBER CAP, 13.5	
6	062711412	2	ネジ SM4.76-32X14	SCREW, PAN SM4.76-32X14	
7	062711012	1	ネジ SM4.76-32X10	SCREW, PAN SM4.76-32X10	
8	S10029209	1	テイクアップカバー	COVER, T/TAKE-UP LEVER	
9	062670812	1	ネジ SM3.57-40X8	SCREW, PAN SM3.57-40X8	
10	S10030002	1	シャトルレースカバーアッセンブリ	SHUTTLE RACE COVER ASSY	
11	153718001	2	タンネジ 5.95	PARTS FOR M&S COMPANY	
12	109239002	2	ナミハネワッシャー	WAVE WASHER	
17	140392009	1	オイルキャップ	OIL CAP	
18	117936001	5	ゴムキャップ 9.4	RUBBER CAP, 9.4	
20	S44493101	1	アイガードアッセンブリ	EYE GUARD ASSY	
20-1	S44483001	1	ヒンジアッセンブリ	HINGE ASSY	
20-2	S44485001	1	アイガード	EYE GUARD	
20-3	061660806	2	ネジ SM3.18-40X8	SCREW, FLAT SM3.18-40X8	
20-4	021660102	2	ナット 1 SM3.18	NUT, 1 SM3.18	
20-5	026030232	2	ワッシャー M3	WASHER, PLAIN M 3	
20-6	S44486101	1	アイガードホルダー A	EYE GUARD HOLDER, A	
20-7	062670512	2	ネジ SM3.57-40X5	SCREW, PAN SM3.57-40X5	
21	062670812	2	ネジ SM3.57-40X8	SCREW, PAN SM3.57-40X8	
22	S17800101	1	内カバー	INSIDE COVER	
23	S17801000	1	カバーパッキン	COVER PACKING	
24	062710812	4	ネジ SM4.76-32X8	SCREW, PAN SM4.76-32X8	
25	SA0695001	1	オイルストッパープレート	OIL STOPPER PLATE	
26	062681012	2	ネジ SM4.37-40X10	SCREW, PAN SM4.37-40X10	
27	S17803001	1	ステップカバー	STEPPING COVER	
28	107321003	1	タンネジ 4.76	SHOULDER SCREW, SM4.76	
29	107017002	1	ナミハネワッシャー	WAVE WASHER	
30	129986001	1	タンネジ 3.57	SCREW	
31	S47177009	1	Yフィーディングガイドシャフトカバー	COVER, Y-FEED GUIDE SHAFT	
32	062680612	4	ネジ SM4.37-40X6	SCREW, PAN SM4.37-40X6	
33	025680232	4	ワッシャー M 4.37	WASHER, PLAIN M 4.37	
34	S17951109	1	フレーム側カバー	FRAME SIDE COVER	
35	062711212	2	ネジ SM4.76-32X12	SCREW, PAN SM4.76-32X12	
36	S18538000	1	カバーパッキン F側	PACKING, F-SIDE COVER	
37	S17952009	1	ベルトカバー U	BELT COVER, U	
38	S47069009	1	ベルトカバー D	BELT COVER, D	
39	062711012	4	ネジ SM4.76-32X10	SCREW, PAN SM4.76-32X10	
43	S47071009	1	フレームカバー YPブラケット	FRAME COVER, YP BRACKET	
44	S47072000	1	YPフレームパッキン	PACKING, YP FRAME	
45	002501002	6	ネジ M5X10	SCREW, PAN M5X10	
46	025050232	6	ワッシャー M 5	WASHER, PLAIN M 5	
112	S53182101	4	スタッド ベルトカバー	STUD, BELT COVER	
113	025710232	4	ワッシャー M 4.76	WASHER, PLAIN M 4.76	

A2. 主体関係 (BAS-341F) / Machine body (BAS-341F)

REF.NO	CODE	Q'TY	品名	NAME OF PARTS	RM
40	S47070001	1	アンナイヅクカバー-R	COVER, R GUIDE SHAFT	
41	060400616	4	バインドM4X6	SCREW, BIND M4X6	
50	S47074001	3	アイドラー	IDLER PULLEY	
51	070638800	3	タマシウ638ZZ	BALL BEARING, 638ZZ	
52	048280242	6	トマアヤウC28	RETAINING RING, INTERNAL C28	
53	S03487001	3	カラー	COLLAR, L	
54	018082022	2	アホム8X20	BOLT, SOCKET M8X20	
55	S47176001	1	ナツト8	NUT, M8	
56	S47073001	1	アイドラーリブ	PULLEY BRACKET, IDLER	
57	017081606	2	ボルトM8X16	BOLT, M8X16	
60	S47075001	1	Yドライブシャフトガード	Y-DRIVING SHAFT GUARD	
61	018501222	2	アホム5X12	BOLT, SOCKET M5X12	
62	028050242	2	バネサカネ2-5	WASHER, SPRING 2-5	
64	S47076009	1	ゴムキャップ24.8	RUBBER CAP, 24.8	
66	S17956001	1	ハリタビヨク	AUXILIARY PLATE	
67	S17957001	1	ハリタビヨクサテL	AUXILIARY PLATE SUPPORT, L	
68	S17958001	1	ハリタビヨクサテR	AUXILIARY PLATE SUPPORT, R	
69	017761212	4	ボルト5.95X12	BOLT, SM5.95X12	
70	025060232	4	ヒラサガネ平ユウ6	WASHER, PLAIN M 6	
71	106629002	8	シメネジ4.37	SCREW, SM4.37	
72	S17959001	1	トウブヒンジ	HEAD HINGE	
73	S17960000	2	ゴムブッシュ	RUBBER BUSH	
74	018123522	2	アホム12X35	BOLT, SOCKET M12X35	
75	S47077001	1	トウブヒンジシャフト	HINGE SHAFT, HEAD	
76	014760622	1	アトメネジ5.95	SET SCREW, SOCKET SM5.95	
77	S17962100	4	クッションゴム	CUSHIONING WASHER	
78	047502242	8	スプリングピンAW5	PIN, SPRING ROLL AW5	
79	S17963001	1	オイルパン	OIL PAN ASSY	
80	S55475002	4	アホム6X10	SCREW, SOCKET(S/PW)M6X10	
83	114486002	1	ホリオリ	OILER	
84	S17965001	1	トウブサテレバ	HEAD SUPPORT LEVER	
85	S17966101	1	トウブサテレババネ	SPRING	
86	S17967001	1	サテレバベース	SUPPORT LEVER BASE	
87	018082022	2	アホム8X20	BOLT, SOCKET M8X20	
88	S17968001	1	サテレバシャフト	SUPPORT LEVER SHAFT	
89	S17969001	1	トウブサテレバ	HEAD SUPPORT SHAFT	
90	014760622	2	アトメネジ5.95	SET SCREW, SOCKET SM5.95	
91	S47078001	1	テーブルカバー	TABLE COVER, BACK	
92	002501003	4	パンネジM5X10	SCREW, PAN M5X10	
93	025050233	4	ヒラサガネ平ユウ5	WASHER, PLAIN M 5	
94	S17971000	1	ガスショック	SHOCK ABSORBER, GAS	
95	S17972001	1	ガスショックサテ	HOLDER, ABSORBER	
96	S17973001	1	ガスショックシャフトU	SHAFT, U	
97	014760622	1	アトメネジ5.95	SET SCREW, SOCKET SM5.95	
98	S55488002	2	アホム8X16	BOLT, SOCKET (S/P WASHER)M8X16	
101	S17974001	1	ガスショックシャフトD	SHAFT, D	
102	S17975100	2	ガスシャフトカラー	SHAFT COLLAR, GAS	
103	025080132	2	ヒラサガネ平ユウ8	WASHER, PLAIN S 8	
104	048060342	2	トマアヤウE6	RETAINING RING, E6	
105	S40417151	1	ベルトVM	BELT, VM	
106	S02445001	1	フィンガード	FINGER GUARD	
107	025350332	2	ヒラサガネ平ユウ3.5	WASHER, PLAIN L 3.5	
108	S18039000	1	ハリタビヨクシート	AUXILIARY PLATE SHEET	
109	S47079301	1	シヤハラクミ	BELLOW ASSY	
110	062680612	4	パンネジ4.37-40X6	SCREW, PAN SM4.37-40X6	
111	S21118001	2	アホム8X90	BOLT, M8X90	
114	S47083009	1	Xフィーダーカバー-R	X-FEED BRACKET COVER, R	
115	S47084009	1	Xフィーダーカバー-L	X-FEED BRACKET COVER, L	
116	106629002	4	シメネジ4.37	SCREW, SM4.37	
117	028080242	2	バネサカネ2-8	WASHER, SPRING 2-8	

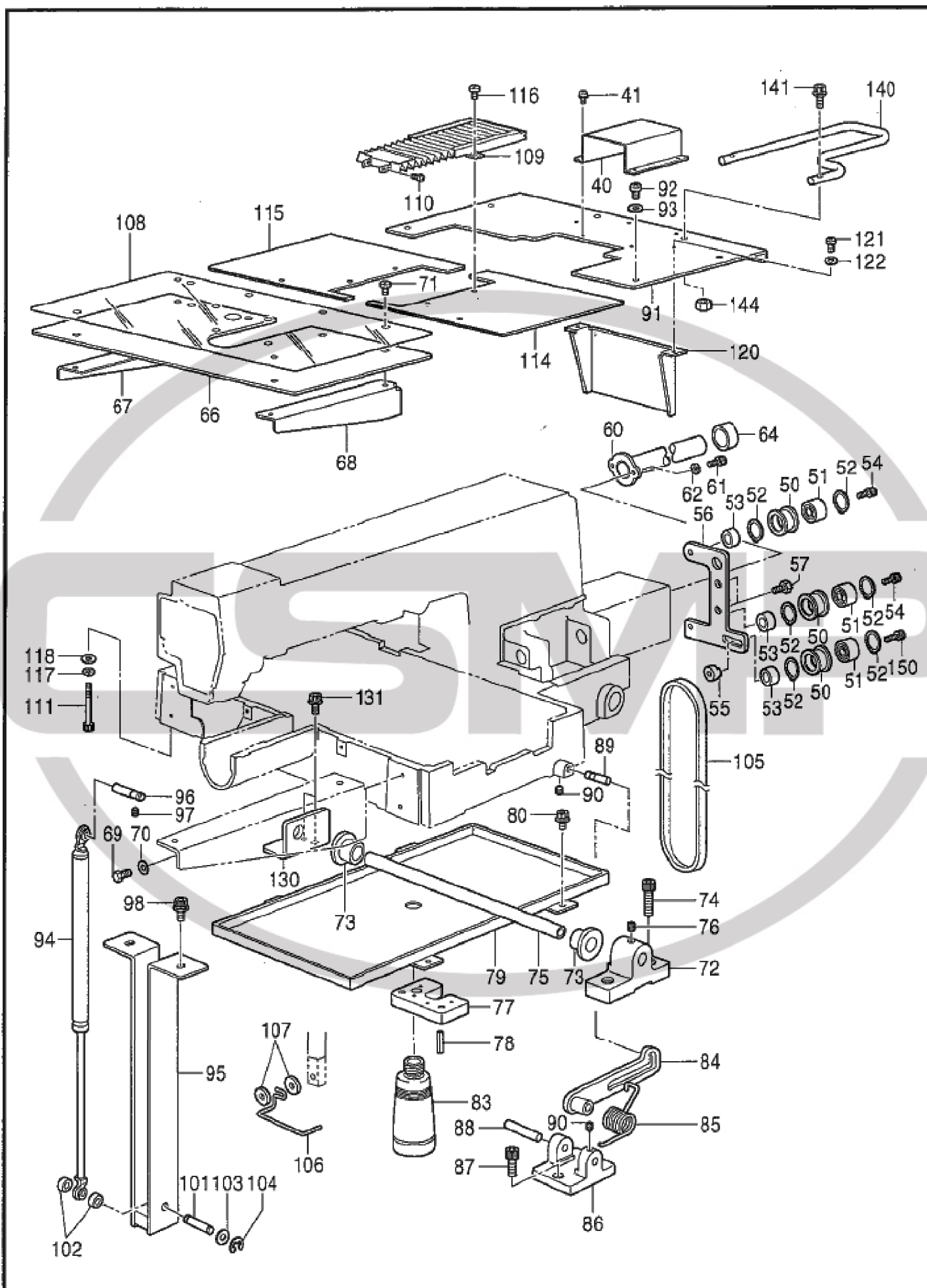

A2. 主体関係 (BAS-341F) / Machine body (BAS-341F)

REF.NO	CODE	QTY	ヒンメイ	NAME OF PARTS	RM
118	025080232	2	ヒラサ ^カ ネ ^ユ 8	WASHER, PLAIN M 8	
120	S47085001	1	テ-フ ^ル シ ^ロ カ ^ハ -D	TABLE COVER, D	
121	062400616	2	ナ ^ハ コ ^M 4X6	SCREW, PAN M4X6	
122	025040236	2	ヒラサ ^カ ネ ^ユ 4	WASHER, PLAIN M 4	
130	S47163001	1	ト ^ウ ブ ^ヒ ン ^ジ イ ^タ	HINGE PLATE, HEAD	
131	S55477002	2	ア ^ホ ル ^サ ク ^M 6X16	BOLT, SOCKET (S/P WASHER)M6X16	
140	S47178001	1	ガ ^ー ド	GUARD	
141	S47270001	2	ア ^ホ ル ^サ ク ^M 6X30	BOLT, SOCKET (S/P WASHER)M6X30	
144	021060106	2	1 ^シ ユ ^ウ ナ ^ツ 6	NUT, 1 M6	
150	018082522	1	ア ^ホ ル ^サ ク ^M 8X25	BOLT, SOCKET M8X25	

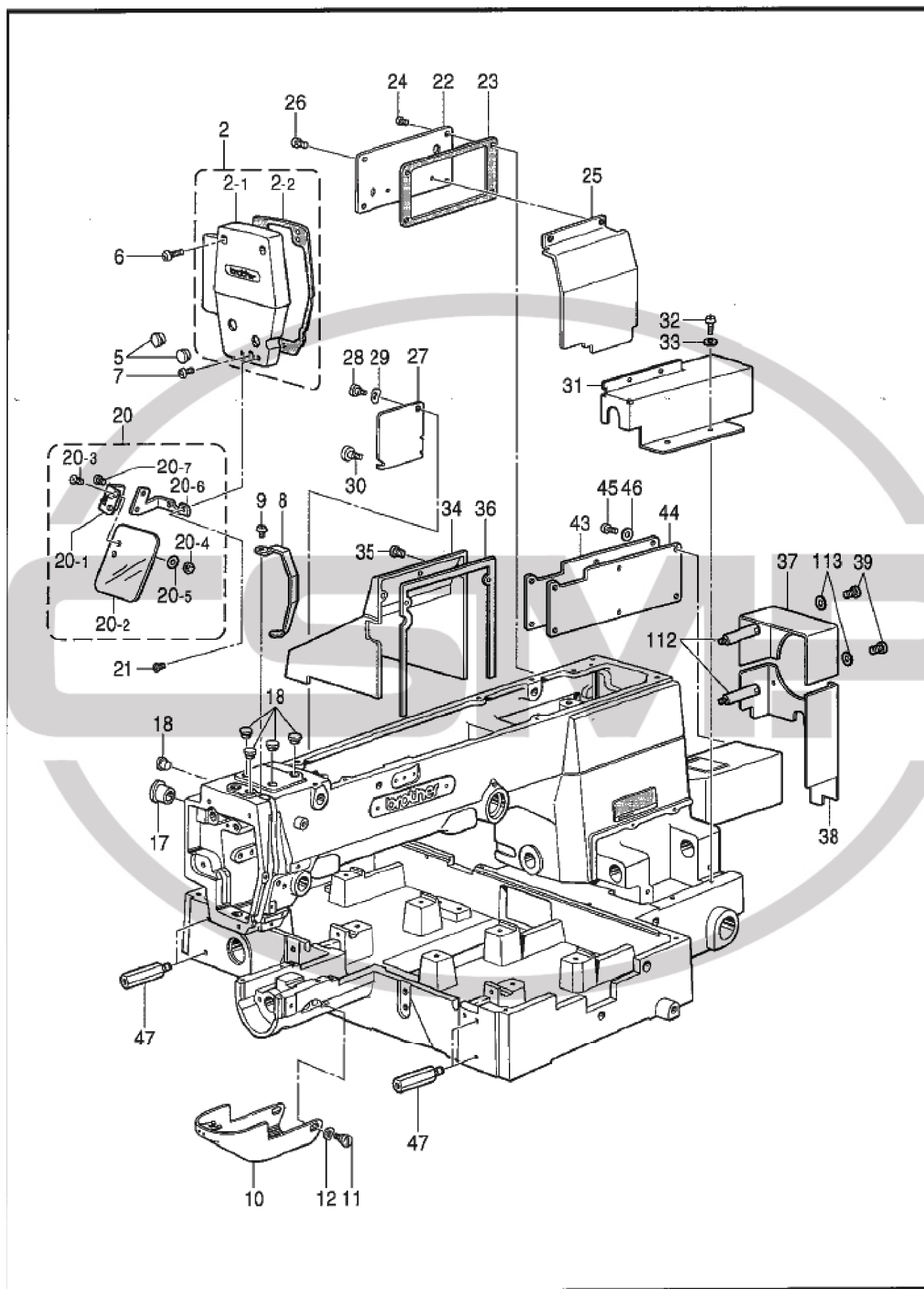

A3. 主体関係 (BAS-342F) / Machine body (BAS-342F)

REF.NO	CODE	QTY	ヒンメイ	NAME OF PARTS	RM
2	S24675001	1	フェイスプレート	FACE PLATE ASSY	
2-1	S25154009	1	フェイスプレート	FACE PLATE	
2-2	S25155100	1	フェイスプレートパッキング	PACKING, F	
5	117934001	2	ゴムセン13.5	RUBBER CAP, 13.5	
6	062711412	2	ナット 4.76-32X14	SCREW, PAN SM4.76-32X14	
7	062711012	1	ナット 4.76-32X10	SCREW, PAN SM4.76-32X10	
8	S10029209	1	テイクアップカバー	COVER, T/TAKE-UP LEVER	
9	062670812	1	ナット 3.57-40X8	SCREW, PAN SM3.57-40X8	
10	S10030002	1	シャトルレースカバー	SHUTTLE RACE COVER ASSY	
11	153718001	2	タンネン 5.95	PARTS FOR M&S COMPANY	
12	109239002	2	ナミハネサガネ	WAVE WASHER	
17	140392009	1	オイルキャップ	OIL CAP	
18	117936001	5	ゴムセン9.4	RUBBER CAP, 9.4	
20	S44493101	1	アイガード	EYE GUARD ASSY	
20-1	S44483001	1	ヒンジ	HINGE ASSY	
20-2	S44485001	1	アイガード	EYE GUARD	
20-3	061660806	2	ネジ 3.18-40X8	SCREW, FLAT SM3.18-40X8	
20-4	021660102	2	ナット 1.18	NUT, 1 SM3.18	
20-5	026030232	2	ワッシャー M3	WASHER, PLAIN M 3	
20-6	S44486101	1	アイガードホルダー A	EYE GUARD HOLDER, A	
20-7	062670512	2	ナット 3.57-40X5	SCREW, PAN SM3.57-40X5	
21	062670812	2	ナット 3.57-40X8	SCREW, PAN SM3.57-40X8	
22	S17800101	1	内カバー	INSIDE COVER	
23	S17801000	1	カバーパッキング	COVER PACKING	
24	062710812	4	ナット 4.76-32X8	SCREW, PAN SM4.76-32X8	
25	SA0695001	1	オイルストッププレート	OIL STOPPER PLATE	
26	062681012	2	ナット 4.37-40X10	SCREW, PAN SM4.37-40X10	
27	S17803001	1	ステップカバー	STEPPING COVER	
28	107321003	1	タンネン 4.76	SHOULDER SCREW, SM4.76	
29	107017002	1	ナミハネサガネ	WAVE WASHER	
30	129986001	1	ネジ 3.57	SCREW	
31	S47177009	1	Yフィードガイドシャフトカバー	COVER, Y-FEED GUIDE SHAFT	
32	062680612	4	ナット 4.37-40X6	SCREW, PAN SM4.37-40X6	
33	025680232	4	ワッシャー M4.37	WASHER, PLAIN M 4.37	
34	S47277109	1	内カバー		
35	062711212	2	ナット 4.76-32X12	SCREW, PAN SM4.76-32X12	
36	S18538000	1	内カバーパッキング	PACKING, F-SIDE COVER	
37	S17952009	1	ベルトカバー U	BELT COVER, U	
38	S47069009	1	ベルトカバー D	BELT COVER, D	
39	062711012	4	ナット 4.76-32X10	SCREW, PAN SM4.76-32X10	
43	S47071009	1	フレームカバー	FRAME COVER, YP BRACKET	
44	S47072000	1	フレームパッキング	PACKING, YP FRAME	
45	002501002	6	ナット M5X10	SCREW, PAN M5X10	
46	025050232	6	ワッシャー M5	WASHER, PLAIN M 5	
47	S30932001	4	サポーター	SUPPORT	
112	S53182101	4	ベルトカバースタッド	STUD, BELT COVER	
113	025710232	4	ワッシャー M4.76	WASHER, PLAIN M 4.76	

A4 . 主体関係 (BAS-342F) / Machine body (BAS-342F)

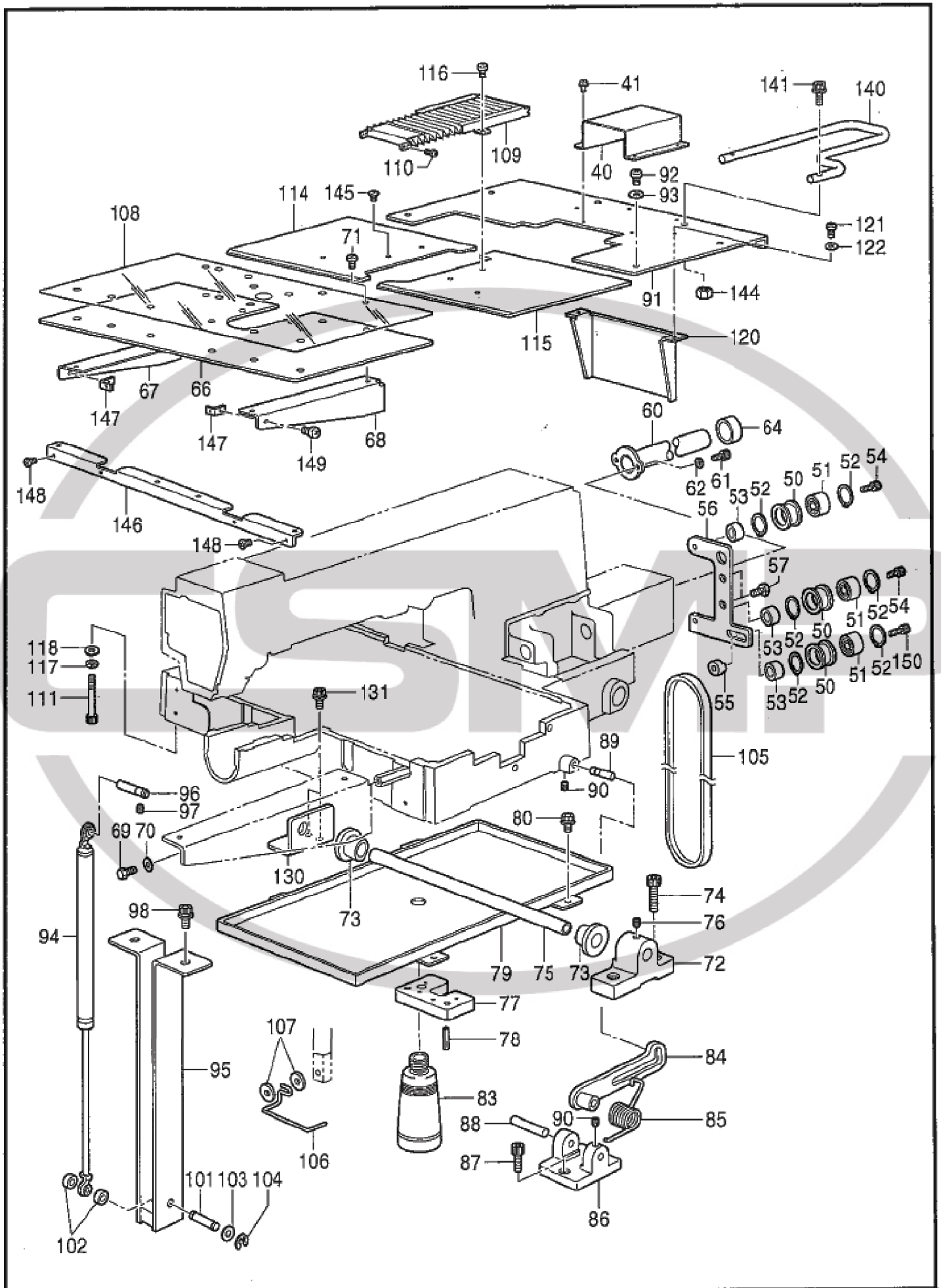

A4. 主体関係 (BAS-342F) / Machine body (BAS-342F)

REF.NO	CODE	QTY	ヒンメイ	NAME OF PARTS	RM
40	S47070001	1	アノイ`クカハ`-R	COVER, R GUIDE SHAFT	
41	060400616	4	ハ`イント`M4X6	SCREW, BIND M4X6	
50	S47074001	3	アイト`ルプ`-リ	IDLER PULLEY	
51	070638800	3	タシ`クウク638ZZ	BALL BEARING, 638ZZ	
52	048280242	6	トメワア`ヨウC28	RETAINING RING, INTERNAL C28	
53	S03487001	3	カラ-L	COLLAR, L	
54	018082022	2	アホ`ルト8X20	BOLT, SOCKET M8X20	
55	S47176001	1	ナツト8	NUT, M8	
56	S47073001	1	アイト`ルプ`-リタイ	PULLEY BRACKET, IDLER	
57	017081606	2	ホ`ルト8X16	BOLT, M8X16	
60	S47075001	1	Yク`ク`カ`-ト`	Y-DRIVING SHAFT GUARD	
61	018501222	2	アホ`ルト5X12	BOLT, SOCKET M5X12	
62	028050242	2	ハ`ネサ`カ`ネ2-5	WASHER, SPRING 2-5	
64	S47076009	1	ゴ`ムキツフ`24.8	RUBBER CAP, 24.8	
66	S47317001	1	ハ`リイタホシ`ヨイタ	AUXILIARY PLATE	
67	S47295001	1	ハ`リイタホシ`ヨイタサH	AUXILIARY PLATE SUPPORT, L	
68	S47296001	1	ハ`リイタホシ`ヨイタサR	AUXILIARY PLATE SUPPORT, R	
69	017761212	4	ホ`ルト5.95X12	BOLT, SM5.95X12	
70	025060232	4	ヒラサ`カ`ネチユ6	WASHER, PLAIN M 6	
71	106629002	12	シメネシ`4.37	SCREW, SM4.37	
72	S17959001	1	トウフ`ヒンシ`	HEAD HINGE	
73	S17960000	2	ゴ`ムフ`ツシ	RUBBER BUSH	
74	018123522	2	アホ`ルト12X35	BOLT, SOCKET M12X35	
75	S47077001	1	トウフ`ヒンシ`シク	HINGE SHAFT, HEAD	
76	014760622	1	アトメシ`5.95	SET SCREW, SOCKET SM5.95	
77	S17962100	4	クツシヨシ`ゴ`ム	CUSHIONING WASHER	
78	047502242	8	スプ`リング`ピン`AW5	PIN, SPRING ROLL AW5	
79	S17963001	1	ア`ラケクミ	OIL PAN ASSY	
80	S55475002	4	アホ`ルトサ`クミ6X10	SCREW, SOCKET(S/PW)M6X10	
83	114486002	1	ホ`リオリ`タイ	OILER	
84	S17965001	1	トウフ`サHレハ`-	HEAD SUPPORT LEVER	
85	S17966101	1	トウフ`サHレハ`-ハ`ネ	SPRING	
86	S17967001	1	サHレハ`-ト`タイ	SUPPORT LEVER BASE	
87	018082022	2	アホ`ルト8X20	BOLT, SOCKET M8X20	
88	S17968001	1	サHレハ`-シ`ンシ`ク	SUPPORT LEVER SHAFT	
89	S17969001	1	トウフ`サHシ`ク	HEAD SUPPORT SHAFT	
90	014760622	2	アトメシ`5.95	SET SCREW, SOCKET SM5.95	
91	S47078001	1	テ`プ`ル`シ`ロカハ`-	TABLE COVER, BACK	
92	002501003	4	ナ`ハ`コ5X10	SCREW, PAN M5X10	
93	025050233	4	ヒラサ`カ`ネチユ5	WASHER, PLAIN M 5	
94	S17971000	1	カ`スプ`リング`	SHOCK ABSORBER, GAS	
95	S17972001	1	カ`スプ`リング`サH	HOLDER, ABSORBER	
96	S17973001	1	カ`スプ`リング`シ`ク	SHAFT, U	
97	014760622	1	アトメシ`5.95	SET SCREW, SOCKET SM5.95	
98	S55488002	2	アホ`ルトサ`クミ8X16	BOLT, SOCKET (S/P WASHER)M8X16	
101	S17974001	1	カ`スプ`リング`シ`クD	SHAFT, D	
102	S17975100	2	GSシ`カラ`	SHAFT COLLAR, GAS	
103	025080132	2	ヒラサ`カ`ネチユ8	WASHER, PLAIN S 8	
104	048060342	2	トメワE6	RETAINING RING, E6	
105	S40417151	1	ロ`エツシ`V`ホ`ルトM	BELT, VM	
106	S02445001	1	フィンガ`-カ`-ト`	FINGER GUARD	
107	025350332	2	ヒラサ`カ`ネチユ3.5	WASHER, PLAIN L 3.5	
108	S47318000	1	ハ`リイタホシ`ヨイタシ`ト	AUXILIARY SHEET, NEEDLE PLATE	
109	S47278301	1	シ`ヤハ`ラ342クミ	BELLOW 342 ASSY	
110	062680612	4	ナ`ハ`コ4.37-40X6	SCREW, PAN SM4.37-40X6	
111	S21118001	2	アホ`ルト8X90	BOLT, M8X90	
114	S47281109	1	Xオクリタ`イカハ`-342L	X-FEED BRACKET COVER, 342 L	
115	S47282109	1	Xオクリタ`イカハ`-342R	X-FEED BRACKET COVER, 342 R	
116	106629002	2	シメネシ`4.37	SCREW, SM4.37	
117	028080242	2	ハ`ネサ`カ`ネ2-8	WASHER, SPRING 2-8	

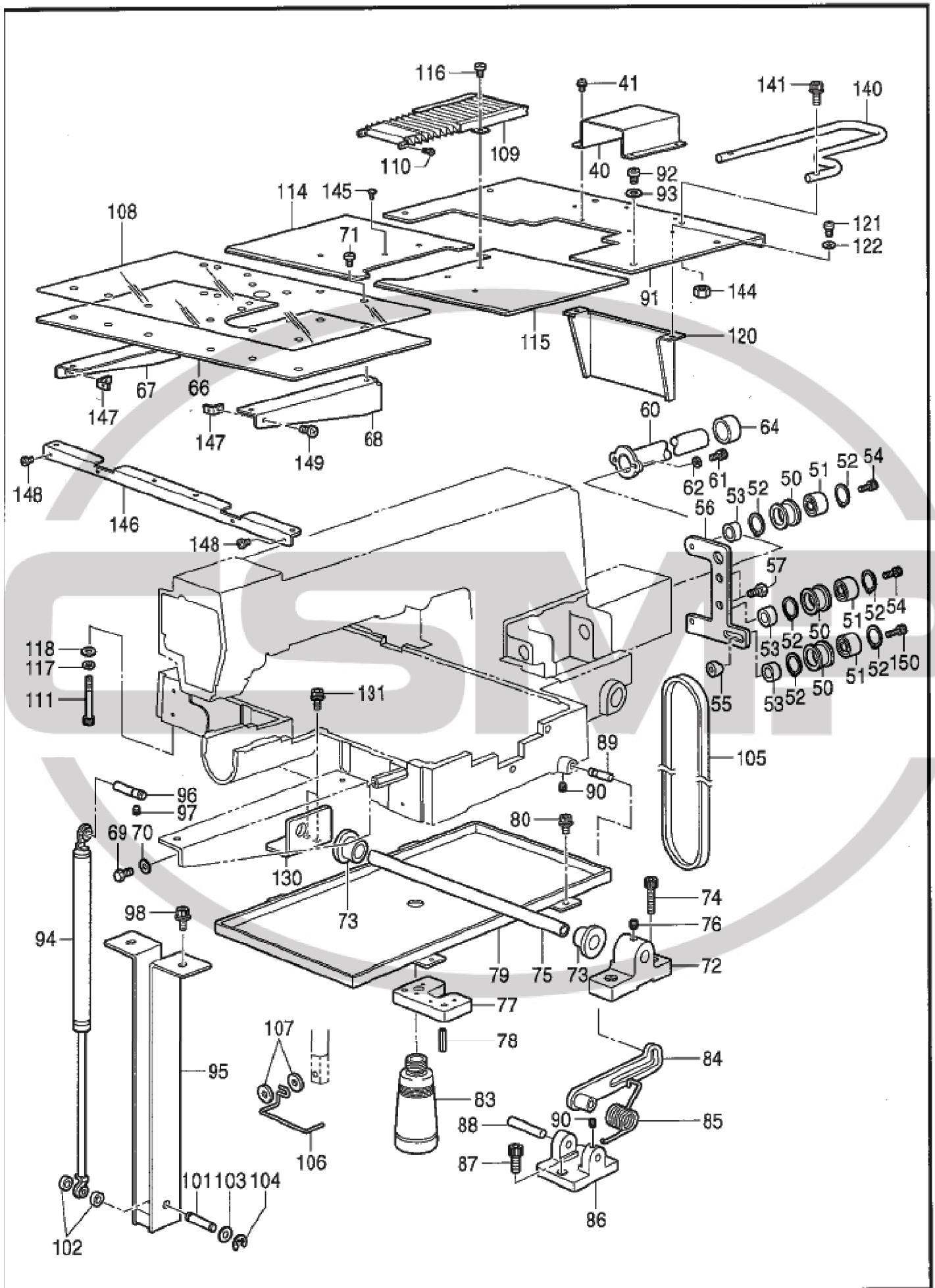

A4. 主体関係 (BAS-342F) / Machine body (BAS-342F)

REF.NO	CODE	Q'TY	ヒンメイ	NAME OF PARTS	RM
118	025080232	2	ヒラサガネワシ	WASHER, PLAIN M 8	
120	S47085001	1	テーブルシヤカバ-D	TABLE COVER, D	
121	062400616	2	ネジ M4X6	SCREW, PAN M4X6	
122	025040236	2	ヒラサガネワシ	WASHER, PLAIN M 4	
130	S47163001	1	ヒンジプレート	HINGE PLATE, HEAD	
131	S55477002	2	ボルトソケット M6X16	BOLT, SOCKET (S/P WASHER)M6X16	
140	S47178001	1	ガード	GUARD	
141	S47270001	2	ボルトソケット M6X30	BOLT, SOCKET (S/P WASHER)M6X30	
144	021060106	2	ナット M6	NUT, 1 M6	
145	117160001	2	ネジ SM4.37	SCREW, FLAT SM4.37	
146	S47319001	1	補助プレート支持	AUXILIARY PLATE SUPPORT, M	
147	S47297001	2	補助プレート支持	AUXILIARY PLATE SUPPORT	
148	062680812	2	ネジ SM4.37-40X8	SCREW, PAN SM4.37-40X8	
149	062771012	2	ネジ SM6.35-40X10	SCREW, PAN SM6.35-40X10	
150	018082522	1	ボルトソケット M8X25	BOLT, SOCKET M8X25	

B. 上軸, 針棒関係 / Upper shaft and needle bar mechanism

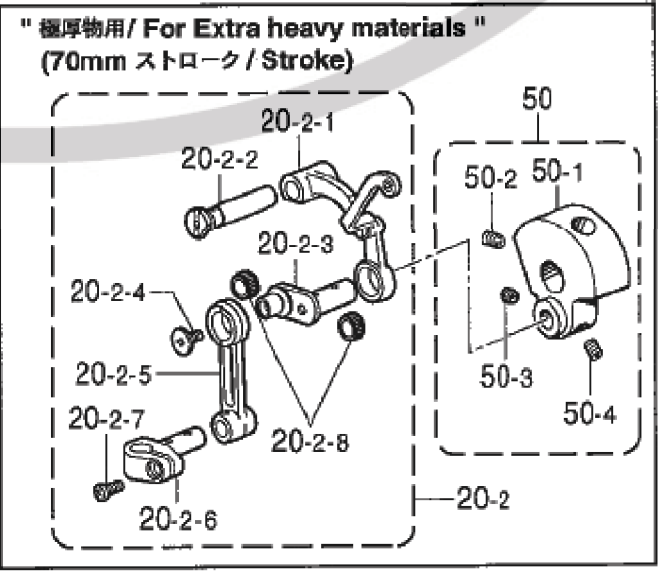
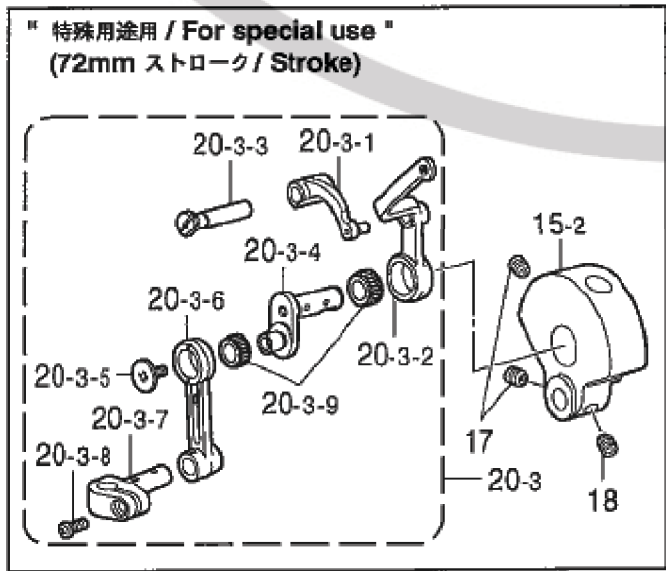
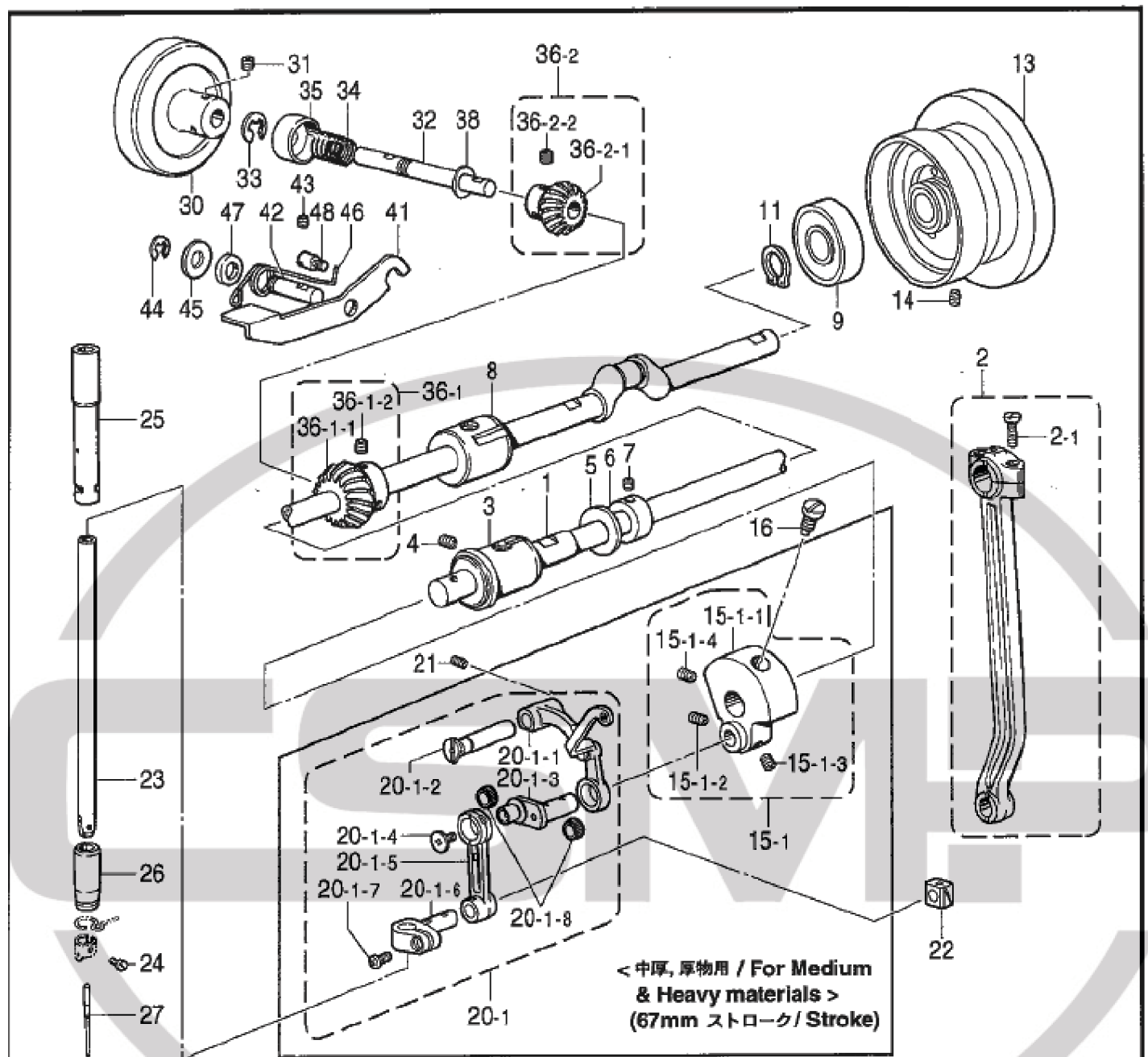

B. 上軸、針棒関係 / Upper shaft and needle bar mechanism

REF.NO	CODE	QTY	ヒンメイ	NAME OF PARTS	RM
1	S47086001	1	ウツシク	UPPER SHAFT	
2	S10036101	1	クランクロッドクミ	CRANK ROD ASSY	
2-1	144712001	2	シメネジ 4.76	SCREW, SM4.76	
3	S10038001	1	ウツシクメタM	UPPER SHAFT BUSH, F	
4	014760622	1	アタメネジ 5.95	SET SCREW, SOCKET SM5.95	
5	101482001	1	レンカンキリイタ	CONNECTING ROD PARTITION PLATE	
6	147763101	1	セツトカー	SET SCREW COLLAR	
7	014770622	2	アタメネジ 6.35クホミ	SET SCREW, SOCKET (CP) SM6.35	
8	140726000	1	ウツシクメタM	UPPER SHAFT BUSH, M	
9	072630260	1	ベアリング 6302VV	BALL BEARING, 6302VV	
11	048150142	1	トメワシクヨウC15	RETAINING RING, EXTERNAL C15	
13	S38035109	1	プーリクミ	PULLEY ASSY	
14	014760622	2	アタメネジ 5.95	SET SCREW, SOCKET SM5.95	
15-1	S37064101	1	ツリアイクランククミ	THREAD TAKE-UP CRANK ASSY	
15-1-1	S10040001	1	デレッククランク	THREAD TAKE-UP CRANK	
15-1-2	014770632	1	アタメネジ 6.35-40X6	SET SCREW, SOCKET(CP) SM6.35X6	
15-1-3	S39973001	1	アタメネジ 6.35-40X5	SET SCREW, SOCKET SM6.35-40X5	
15-1-4	014770632	1	アタメネジ 6.35-40X6	SET SCREW, SOCKET(CP) SM6.35X6	
15-2	S49584000	1	特殊用途用 (オプション、72mmストローク) ツリアイクランクD	"For Special use (Option, 72 mm Stroke)" THREAD TAKE-UP CRANK, D	
16	100250001	1	シメネジ 7.14	SCREW, SM7.14	
17	014770632	2	アタメネジ 6.35-40X6	SET SCREW, SOCKET(CP) SM6.35X6	
18	S55877001	1	シメネジ 6.35クホミ	SET SCREW, (CP) SM6.35-40X4	
20-1	S47087001	1	ハコウレンカンAクミ	THREAD TAKE-UP LEVER SET, A	
20-1-1	S47088001	1	デレッククミ	THREAD TAKE-UP LEVER ASSY	
20-1-2	S47091001	1	デレックサシク	THREAD TAKE-UP SUPPORT SHAFT	
20-1-3	152237101	1	ハコウクランク	NEEDLE BAR CRANK	
20-1-4	145465001	1	シメネジ 3.57L	SCREW, SM3.57-40X6 L	
20-1-5	S47092001	1	ハコウレンカン	NEEDLE BAR CONNECTING ROD	
20-1-6	S02268001	1	ハコウクダキ	NEEDLE BAR CLAMP	
20-1-7	062680812	1	ナット 437-40X8	SCREW, PAN SM4.37-40X8	
20-1-8	116735000	2	ニトメベアリング	NEEDLE BEARING	
20-2	S47093001	1	特殊用途用 (オプション、70mmストローク) ハコウレンカンBクミ	"For Extra heavy materials (Option, 70 mm Stroke)" THREAD TAKE-UP LEVER SET, B	
20-2-1	S47088001	1	デレッククミ	THREAD TAKE-UP LEVER ASSY	
20-2-2	S47091001	1	デレックサシク	THREAD TAKE-UP SUPPORT SHAFT	
20-2-3	154624101	1	ハコウクランクB	NEEDLE BAR CRANK, B	
20-2-4	145465001	1	シメネジ 3.57L	SCREW, SM3.57-40X6 L	
20-2-5	S47092001	1	ハコウレンカン	NEEDLE BAR CONNECTING ROD	
20-2-6	S02268001	1	ハコウクダキ	NEEDLE BAR CLAMP	
20-2-7	062680812	1	ナット 437-40X8	SCREW, PAN SM4.37-40X8	
20-2-8	116735000	2	ニトメベアリング	NEEDLE BEARING	
20-3	S55649001	1	特殊用途用 (オプション、72mmストローク) ハコウレンカンDクミ	"For Special use (Option, 72 mm Stroke)" THREAD TAKE-UP LEVER SET, D	
20-3-1	S49587001	1	デレックサシ	THREAD TAKE-UP SUPPORT	
20-3-2	S49588001	1	デレックレバ	THREAD TAKE-UP LEVER	
20-3-3	S47091001	1	デレックサシク	THREAD TAKE-UP SUPPORT SHAFT	
20-3-4	S49589001	1	ハコウクランク	NEEDLE BAR CRANK	
20-3-5	145465001	1	シメネジ 3.57L	SCREW, SM3.57-40X6 L	
20-3-6	S47092001	1	ハコウレンカン	NEEDLE BAR CONNECTING ROD	
20-3-7	S02268001	1	ハコウクダキ	NEEDLE BAR CLAMP	
20-3-8	062680812	1	ナット 437-40X8	SCREW, PAN SM4.37-40X8	
20-3-9	147777000	2	ニトメベアリング	NEEDLE BEARING	
21	014760622	1	アタメネジ 5.95	SET SCREW, SOCKET SM5.95	
22	142211001	1	カクコ	SLIDE BLOCK	

B. 上軸, 針棒関係 / Upper shaft and needle bar mechanism

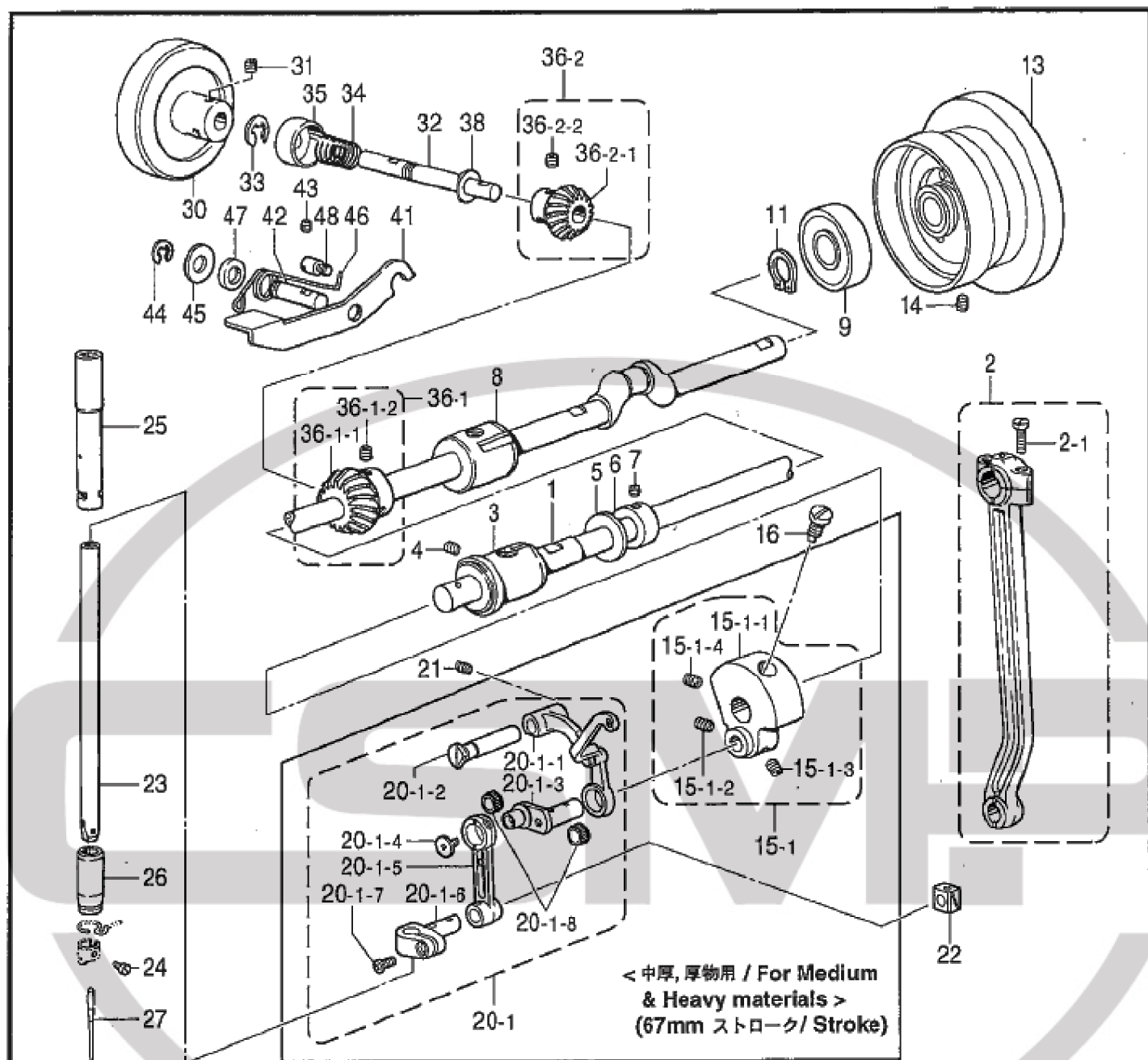

" 特殊用途用 / For special use "
(72mm ストローク / Stroke)

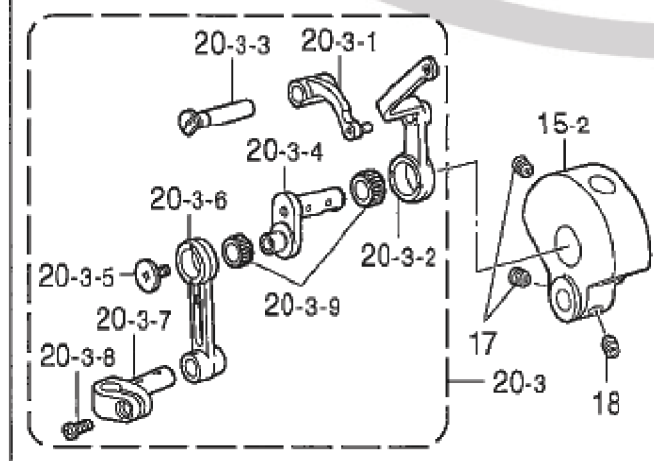

" 極厚物用 / For Extra heavy materials "
(70mm ストローク / Stroke)

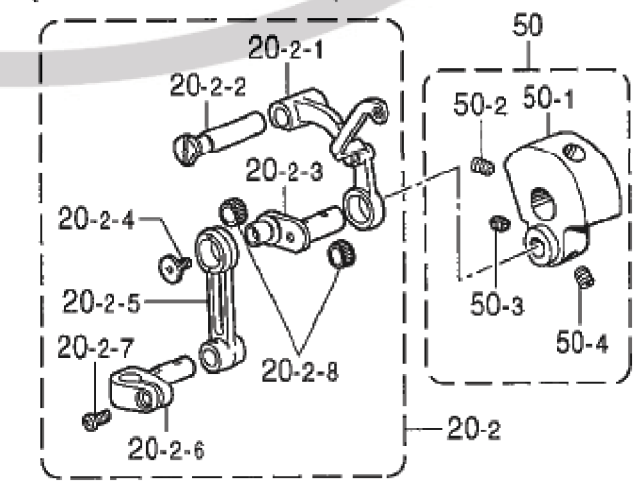

B. 上軸、針棒関係 / Upper shaft and needle bar mechanism

REF.NO	CODE	QTY	ヒンメイ	NAME OF PARTS	RM
23	S02269001	1	針棒	NEEDLE BAR	
24	144458001	1	アタメネジ 3.57	SET SCREW, SM3.57-40X4.5	
25	S10044001	1	針棒カメタBU	NEEDLE BAR BUSH, U	
26	152243001	1	針棒カメタD	NEEDLE BAR BUSH, D	
			<中厚物用>	<For Medium materials>	
27	107415016	1	ミシン針DPX5 (#16)	NEEDLE, DPX5 (#16)	
			<厚物用>	<For Heavy materials>	
27	145646021	1	ミシン針DPX17 (#21)	NEEDLE, DPX17 (#21)	
			" オプションパーツ "	"OPTION PARTS"	
27	107415009	1	ミシン針DPX5 (#9)	NEEDLE, DPX5 (#9)	
27	107415011	1	ミシン針DPX5 (#11)	NEEDLE, DPX5 (#11)	
27	107415014	1	ミシン針DPX5 (#14)	NEEDLE, DPX5 (#14)	
27	107415018	1	ミシン針DPX5 (#18)	NEEDLE, DPX5 (#18)	
27	107415019	1	ミシン針DPX5 (#19)	NEEDLE, DPX5 (#19)	
27	107415021	1	ミシン針DPX5 (#21)	NEEDLE, DPX5 (#21)	
27	107415023	1	ミシン針DPX5 (#23)	NEEDLE, DPX5 (#23)	
27	154763010	1	ミシン針DPX5KN (#10)	NEEDLE, DPX5KN (#10)	
27	S37929009	1	ミシン針DPX5NY (#9)	NEEDLE, DPX5NY (#9)	
27	S37929016	1	ミシン針DPX5NY (#16)	NEEDLE, DPX5NY (#16)	
27	145646011	1	ミシン針DPX17 (#11)	NEEDLE, DPX17 (#11)	
27	145646014	1	ミシン針DPX17 (#14)	NEEDLE, DPX17 (#14)	
27	145646016	1	ミシン針DPX17 (#16)	NEEDLE, DPX17 (#16)	
27	145646018	1	ミシン針DPX17 (#18)	NEEDLE, DPX17 (#18)	
27	145646019	1	ミシン針DPX17 (#19)	NEEDLE, DPX17 (#19)	
27	145646024	1	ミシン針DPX17 (#24)	NEEDLE, DPX17 (#24)	
27	145646025	1	ミシン針DPX17 (#25) (極厚物用)	NEEDLE, DPX17 (#25) (For Extra heavy materials)	
27	S37928019	1	ミシン針DPX17NY (#19)	NEEDLE, DPX17NY (#19)	
27	S24511007	1	ミシン針3355-01MR (MR7)	NEEDLE, 3355-01 MR (MR7)	
30	S23839001	1	プーリ	PULLEY	
31	014760622	2	アタメネジ 5.95	SET SCREW, SOCKET SM5.95	
32	S23840001	1	プーリシャフト	PULLEY SHAFT	
33	048060342	2	トメ7E6	RETAINING RING, E6	
34	140651001	1	ストップバネ	SPRING, COMPRESSION	
35	S24593001	1	バネキャップ	CAP, SPRING	
36-1	183816001	1	ウツシカハベルギヤ	UPPER SHAFT BEVEL GEAR ASSY	
36-1-1	140379001	1	ウツシカハベルギヤ	UPPER SHAFT BEVEL GEAR	
36-1-2	014770622	2	アタメネジ 6.35カメ	SET SCREW, SOCKET (CP) SM6.35	
36-2	183305001	1	ウツシカハベルギヤ	VERTICAL BEVEL GEAR ASSY	
36-2-1	140380001	1	ウツシカハベルギヤ	VERTICAL BEVEL GEAR, U	
36-2-2	014770622	2	アタメネジ 6.35カメ	SET SCREW, SOCKET (CP) SM6.35	
38	154596000	1	イキリカムバクッション	CUSHION	
41	157829001	1	ストップ	STOPPER	
42	S23841001	1	ストップシャフト	STOPPER SHAFT	
43	014760622	1	アタメネジ 5.95	SET SCREW, SOCKET SM5.95	
44	048060342	1	トメ7E6	RETAINING RING, E6	
45	159947001	1	ストップワッシャー	WASHER, PLAIN 8	
46	157828001	1	バネ	SPRING	
47	S03611001	1	カラーS	COLLAR, S	
48	S08967001	1	シメネジ 4.76	SCREW, SM4.76	
			" 特殊用途用 (オプション、72mmストローク) "	"For Special use (Option, 72 mm Stroke)"	
50	S59134001	1	スリットクランク	THREAD TAKE-UP CRANK B ASSY	
50-1	154623000	1	スリットクランク	THREAD TAKE-UP CRANK, B	
50-2	014770632	1	アタメネジ 6.35-40X6	SET SCREW, SOCKET(CP) SM6.35X6	
50-3	S55877001	1	トメネジ 6.35カメ	SET SCREW, (CP) SM6.35-40X4	
50-4	014770632	1	アタメネジ 6.35-40X6	SET SCREW, SOCKET(CP) SM6.35X6	

C1. 送り関係 (BAS-341F) / Feed mechanism (BAS-341F)

REF.NO	CODE	QTY	ヒンメイ	NAME OF PARTS	RM
1	S47096201	1	オウゲ'ソクミ	WORK CLAMP ARM SET	
1-1	S47097201	1	オウゲ'クミ	WORK CLAMP ARM ASSY	
1-1-5	SA1933001	2	オウゲ'ソクミ	SUPPORT PLATE	
1-1-6	018401236	4	アホ'ト4X12	BOLT, SOCKET M4X12	
1-1-7	028040246	4	ハ'ネサ'カ'ネ2-4	WASHER, SPRING 2-4	
1-1-8	018401236	4	アホ'ト4X12	BOLT, SOCKET M4X12	
1-1-9	021400216	4	2'ユナ'ト4	NUT, 2 M4	
1-2	S23443000	2	リヤブ'ツシ12.7	BUSH, 12.7	
1-3	014680422	2	アトメシ'4.37クホ'ミ	SET SCREW, SOCKET (CP) SM4.37	
1-4	S18038101	2	エアシリンダ'	AIR CYLINDER	
1-5	S55533000	4	エルボ' M5	ELBOW, M5	
1-6	S17811001	1	エアシリンダ'サシク	AIR CYLINDER SUPPORT SHAFT	
1-7	146354001	2	サ'カ'ネ	WASHER, PLAIN 5	
1-8	048040342	2	トメ'エ4	RETAINING RING, E4	
1-9	S03801101	2	シリンダ'クギ'テ	JOINT, CYLINDER	
1-10	110168001	2	コロ'シク	ROLLER SHAFT	
1-11	S17812001	2	オウゲ'レバ'-U	KNEE LIFTER LIFTING LEVER, U	
1-12	S17813001	2	オウゲ'レバ'-D	LEVER, D	
1-13	S17814001	1	オウゲ'シフト'シク	KNEE LIFTER LIFTING SHAFT	
1-14	048050342	1	トメ'エ5	RETAINING RING, E5	
1-15	143591001	1	スラスト'リング'	THRUST RING	
1-16	S21775001	1	セツ'カ'ネ'クミ	SET SCREW COLLAR ASSY	
1-16-1	139096001	1	セツ'カ'ネ'	SET SCREW COLLAR	
1-16-2	014680422	2	アトメシ'4.37クホ'ミ	SET SCREW, SOCKET (CP) SM4.37	
1-17	014760622	1	アトメシ'5.95	SET SCREW, SOCKET SM5.95	
1-18	018400832	2	アホ'ト4X8	BOLT, SOCKET M4X8	
1-19	025040132	2	ヒラ'サ'カ'ネ'ヨウ4	WASHER, PLAIN S 4	
1-20	S17816001	1	スライダ'-サシ'シク	SUPPORT SHAFT, SLIDER	
1-21	S18636101	1	スライダ'-オシ'ハ'ネ	SPRING	
1-22	014760622	1	アトメシ'5.95	SET SCREW, SOCKET SM5.95	
1-23	S17817009	2	オウゲ'ソクミ	WORK CLAMP ASSY	
1-24	S17809009	2	オウゲ'ソクミ'ガイド'	WORK CLAMP GUIDE ASSY	
1-25	S17823100	4	オウゲ'ソクミ'リテー'ナ'クミ	WORK CLAMP RETAINER ASSY	
1-26	018501622	4	アホ'ト5X16	BOLT, SOCKET M5X16	
2	S17825001	1	オウゲ'ソクミ'SEL	WORK CLAMP, SE L	
3	S17826001	1	オウゲ'ソクミ'SER	WORK CLAMP, SE R	
4	018501222	2	アホ'ト5X12	BOLT, SOCKET M5X12	
8	SA1906001	1	341'オウゲ'ソクミ	WORK CLAMP ASSY, 341	
8-1	SA1907001	1	341'オウゲ'	WORK CLAMP, 341	
8-2	S48619000	2	341'オウゲ'クッション'	CUSHION, 341 WORK CLAMP	
9	153057102	4	オウゲ'ソクミ'ネジ'	SCREW, ROUND W/SOCKET SM4.37	
10	025680232	4	ヒラ'サ'カ'ネ'ヨウ4.37	WASHER, PLAIN M 4.37	
12	SA1899001	1	オウゲ'ソクミ'サシ'イ'クミ'341	W-CLAMP ARM SUPPORT PLATE, 341	
13	149482001	4	アツキ'ネジ'ソクミ'ト'6X15	BOLT, FLAT W/SOCKET M6X15	
14	S47106101	1	V41'オウゲ'ソクミ'イ'クミ	FEED BRACKET ASSY, V41	
14-1	S47107001	1	Y'オウゲ'ソクミ'イ'クミ'341	FEED BRACKET, 341	
14-2	062300612	14	ハ'コ'3X6	SCREW, PAN M3X6	
14-3	004300513	2	サ'ラ'コ'3X5	SCREW, FLAT M3X5	
14-4	S47108000	2	341'リ'ネ'ア'カ'イ'ト'Y	LINER GUIDE, Y 341	
14-5	018300532	14	アホ'ト3X5	BOLT, SOCKET M3X5	
14-6	S47109101	1	341'オウゲ'ソクミ'イ'クミ'X	FEED BRACKET, X 341	
14-7	S47326001	2	X'カ'ハ'ス'ハ'-サ'341	SPACER, 341 X-COVER	
14-8	004300513	4	サ'ラ'コ'3X5	SCREW, FLAT M3X5	
15	062300512	14	ハ'コ'3X5	SCREW, PAN M3X5	
16	061300616	2	サ'ラ'コ'3X6	SCREW, FLAT M3X6	
17	S39110001	2	ホ'ルト'5.95-28X14	BOLT, W/SOCKET SM5.95-28X14	
18	025060132	2	ヒラ'サ'カ'ネ'ヨウ6	WASHER, PLAIN S 6	
19	SA1898001	1	X'オウゲ'ソクミ'サシ'イ'クミ'341	X-FEED SHAFT SUPPORT, 341	
20	S24590001	1	X'オウゲ'ソクミ'	X-FEED SHAFT	
21	014760622	2	アトメシ'5.95	SET SCREW, SOCKET SM5.95	

C1. 送り関係 (BAS-341F) / Feed mechanism (BAS-341F)

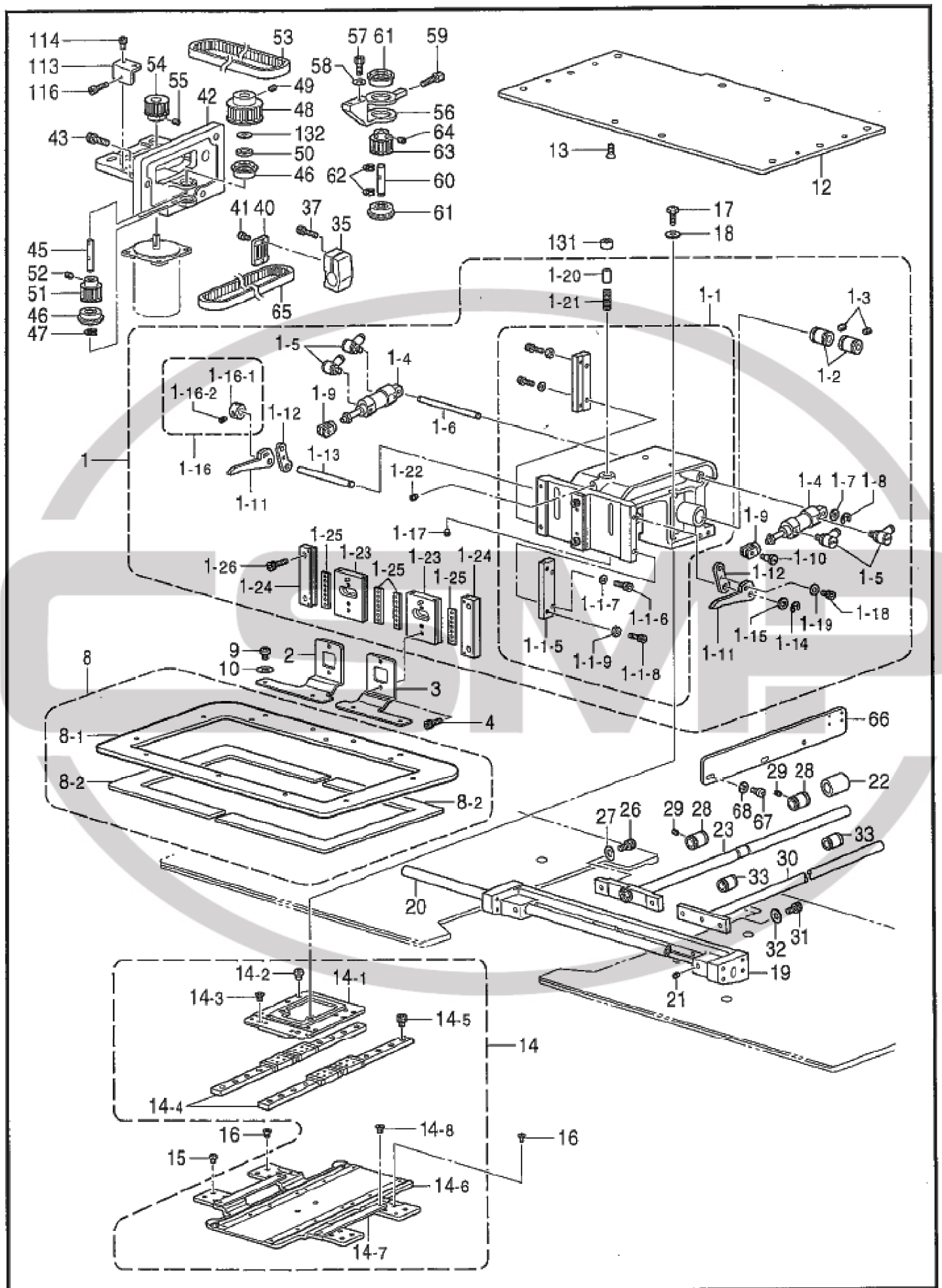

C1. 送り関係 (BAS-341F) / Feed mechanism (BAS-341F)

REF.NO	CODE	QTY	ヒンメイ	NAME OF PARTS	RM
22	S47165000	1	リニアブッシュスリーブ	SLEEVE, LINEAR BUSH	
23	S47111101	1	Yドライブシャフト	Y-DRIVING SHAFT ASSY	
26	018501022	2	ボルト M5X10	BOLT, SOCKET M5X10	
27	S03677001	2	ワッシャー	WASHER	
28	S47112000	2	リニアブッシュ16	LINEAR BUSH, 16	
29	014680422	2	セットネジ 4.37x6mm	SET SCREW, SOCKET (CP) SM4.37	
30	S47113001	1	Yドライブガイドシャフト	Y-DRIVING GUIDE SHAF	
31	018501022	2	ボルト M5X10	BOLT, SOCKET M5X10	
32	S03677001	2	ワッシャー	WASHER	
33	S10103001	2	ボールブッシュ	BALL BUSH	
35	SA0696001	1	Yドライブシャフトホルダ	Y-DRIVING SHAFT HOLDER	
37	018062022	1	ボルト M6X20	BOLT, SOCKET M6X20	
40	SA0694001	1	Yベルトホルダ	Y-BELT HOLDER	
41	018680822	2	ボルト M4.37x8	BOLT, SOCKET SM4.37X8	
42	S47116001	1	YドライブPモータブラケット	P-MOTOR BRACKET, Y-DRIVING	
43	018082022	3	ボルト M8X20	BOLT, SOCKET M8X20	
45	S47119001	1	Yドライブプーリー	Y-PULLEY SHAFT, F	
46	076000850	2	ボールベアリング 6000ZZNR	BALL BEARING, 6000ZZNR	
47	048080342	1	リテーニングリング E8	RETAINING RING, E8	
48	SA0752001	1	アイドルプーリー 342	IDLE PULLEY, 342	
49	014770622	2	セットネジ 6.35x6mm	SET SCREW, SOCKET (CP) SM6.35	
50	156070002	1	スペーサ	SPACER	
51	SA0750001	1	タイミングプーリー 342	TIMING PULLEY, 342	
52	014770622	2	セットネジ 6.35x6mm	SET SCREW, SOCKET (CP) SM6.35	
53	SA0749000	1	モータタイミングベルト 342	MOTOR TIMING BELT, 342	
54	SA0751001	1	モータタイミングプーリー 342	MOTOR TIMING PULLEY, 342	
55	014770622	2	セットネジ 6.35x6mm	SET SCREW, SOCKET (CP) SM6.35	
56	S47122000	1	Yドライブプーリーブラケット	Y-PULLEY BRACKET	
57	018502522	2	ボルト M5X25	BOLT, SOCKET M5X25	
58	025050232	2	ワッシャー 平 M5	WASHER, PLAIN M 5	
59	018503022	1	ボルト M5X30	BOLT, SOCKET M5X30	
60	S47123001	1	Yドライブプーリー R	Y-PULLEY SHAFT, R	
61	076000850	2	ボールベアリング 6000ZZNR	BALL BEARING, 6000ZZNR	
62	048080342	2	リテーニングリング E8	RETAINING RING, E8	
63	SA0750001	1	タイミングプーリー 342	TIMING PULLEY, 342	
64	014770622	2	セットネジ 6.35x6mm	SET SCREW, SOCKET (CP) SM6.35	
65	SA0748000	1	Yタイミングベルト 342	Y-TIMING BELT, 342	
66	S47125001	1	Yセンサ調整プレート	Y-SENSOR SETTING PLATE	
67	062680812	2	ネジ M4.37-40X8	SCREW, PAN SM4.37-40X8	
68	025680232	2	ワッシャー 平 M 4.37	WASHER, PLAIN M 4.37	
113	S47173001	1	Yタイミングベルト調整プレート	Y-TIMING BELT ADJUSTING PLATE	
114	018501022	2	ボルト M5X10	BOLT, SOCKET M5X10	
116	018502522	1	ボルト M5X25	BOLT, SOCKET M5X25	
131	S17815000	1	スライダー	SLIDER	
132	025100132	1	ワッシャー 平 S 10	WASHER, PLAIN S 10	

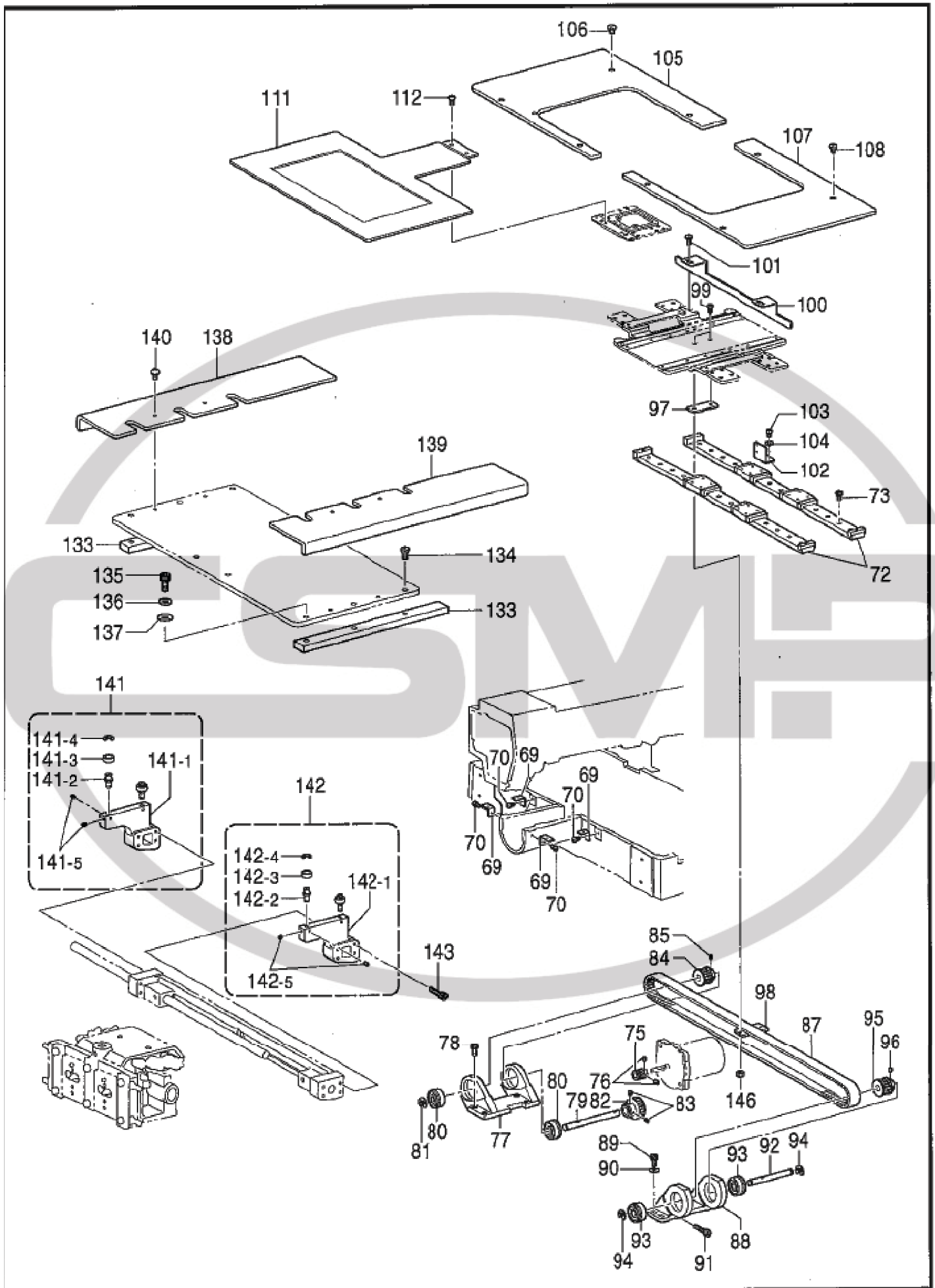

C2. 送り関係 (BAS-341F) / Feed mechanism (BAS-341F)

REF.NO	CODE	QTY	品名	NAME OF PARTS	RM
69	S10091201	4	ハイトボンド437	AUXILIARY PLATE SUPPORT	
70	060680712	4	ハイト 437-40X7	SCREW, BIND SM4.37-40X7	
72	S47126000	2	Xリニアガイド	X-LINEAR GUIDE	
73	018401036	9	ボルト M4X10	BOLT, SOCKET M4X10	
75	S47172001	1	外歯ギヤ20	DRIVING GEAR, 20	
76	014760622	2	アタメネジ 5.95	SET SCREW, SOCKET SM5.95	
77	S47127100	1	X7-リール	X-PULLEY BASE, L	
78	018501622	4	ボルト M5X16	BOLT, SOCKET M5X16	
79	S47129001	1	X7-リール	X-PULLEY SHAFT, L	
80	076000850	2	ボールベアリング 6000ZZNR	BALL BEARING, 6000ZZNR	
81	048080342	1	トリプルE8	RETAINING RING, E8	
82	S47128001	1	アイドルギヤ32	IDLER GEAR, 32	
83	014770622	2	アタメネジ 6.35	SET SCREW, SOCKET (CP) SM6.35	
84	SA0750001	1	タイミングプーリ342	TIMING PULLEY, 342	
85	014770622	2	アタメネジ 6.35	SET SCREW, SOCKET (CP) SM6.35	
87	SA0747000	1	Xタイミングベルト342	X-TIMING BELT, 342	
88	S47130100	1	X7-リール	X-PULLEY BRACKET, R	
89	018501622	4	ボルト M5X16	BOLT, SOCKET M5X16	
90	025050232	4	ワッシャー M5	WASHER, PLAIN M 5	
91	018502522	1	ボルト M5X25	BOLT, SOCKET M5X25	
92	S47131001	1	X7-リール	X-PULLEY SHAFT, R	
93	076000850	2	ボールベアリング 6000ZZNR	BALL BEARING, 6000ZZNR	
94	048080342	2	トリプルE8	RETAINING RING, E8	
95	SA0750001	1	タイミングプーリ342	TIMING PULLEY, 342	
96	014770622	2	アタメネジ 6.35	SET SCREW, SOCKET (CP) SM6.35	
97	S47325001	1	XタイミングベルトホルダーU	X-TIMING BELT HOLDER, U	
98	SA0693001	1	Xベルトホルダー	X-BELT HOLDER	
99	062681012	2	ナット M4.37-40X10	SCREW, PAN SM4.37-40X10	
100	S49042001	1	X軸原点マーク	X-AXIS HOME POSITION DOG	
101	060680712	2	ハイト 437-40X7	SCREW, BIND SM4.37-40X7	
102	S49043001	1	Xセンサートリップ	SETTING PLATE, X-SENSOR	
103	062680812	2	ナット M4.37-40X8	SCREW, PAN SM4.37-40X8	
104	025680232	2	ワッシャー M4.37	WASHER, PLAIN M 4.37	
105	S47135101	1	XYフィーダーカバーL	XY-FEED BRACKET COVER, L	
106	106629002	4	ネジ M4.37	SCREW, SM4.37	
107	S47136101	1	XYフィーダーカバーR	XY-FEED BRACKET COVER, R	
108	106629002	4	ネジ M4.37	SCREW, SM4.37	
111	S47138101	1	フィーダープレート	FEED PLATE, B	
112	S10352101	2	スクエアネジ	SCREW, ROUND W/SOCKET SM4.37	
133	SA1900001	2	ガイドローラー341	GUIDE ROLLER RAIL, 341	
134	S35324001	2	ダンパーM4	SHOULDER SCREW, M4	
135	018061636	4	ボルト M6X16	BOLT, SOCKET M6X16	
136	028060246	4	ワッシャー 2-6	WASHER, SPRING 2-6	
137	025060236	4	ワッシャー M6	WASHER, PLAIN M 6	
138	SA1901001	1	ガイドローラーカバー341L	GUIDE ROLLER COVER 341, L	
139	SA1902001	1	ガイドローラーカバー341R	GUIDE ROLLER COVER 341, R	
140	008400604	4	トラスM4X6	SCREW, TRUSS M4X6	
141	SA1509001	1	ガイドローラーベースL	GUIDE ROLLER BASE L ASSY	
141-1	SA0686000	1	ガイドローラー	GUIDE ROLLER BASE, L	
141-2	SA0688001	2	偏心シャフト	ECCENTRIC SHAFT	
141-3	530138001	2	マイクロベアリング8	MICRO BEARING, 8	
141-4	048060342	2	トリプルE6	RETAINING RING, E6	
141-5	014500522	4	アタメネジ 5	SET SCREW, SOCKET (CP) M5X5	
142	SA1510001	1	ガイドローラーベースR	GUIDE ROLLER BASE R ASSY	
142-1	SA0687000	1	ガイドローラー	GUIDE ROLLER BASE, R	
142-2	SA0688001	2	偏心シャフト	ECCENTRIC SHAFT	
142-3	530138001	2	マイクロベアリング8	MICRO BEARING, 8	
142-4	048060342	2	トリプルE6	RETAINING RING, E6	
142-5	014500522	4	アタメネジ 5	SET SCREW, SOCKET (CP) M5X5	
143	018502536	8	ボルト M5X25	BOLT, SOCKET M5X25	
146	021680212	2	ナット M4.37	NUT, 2 SM4.37	

< A=1 : 縫製エリア250×150mm / Sewing area " 250×150mm " >
 < A=2 : 縫製エリア180×100mm / Sewing area " 180×100mm " >

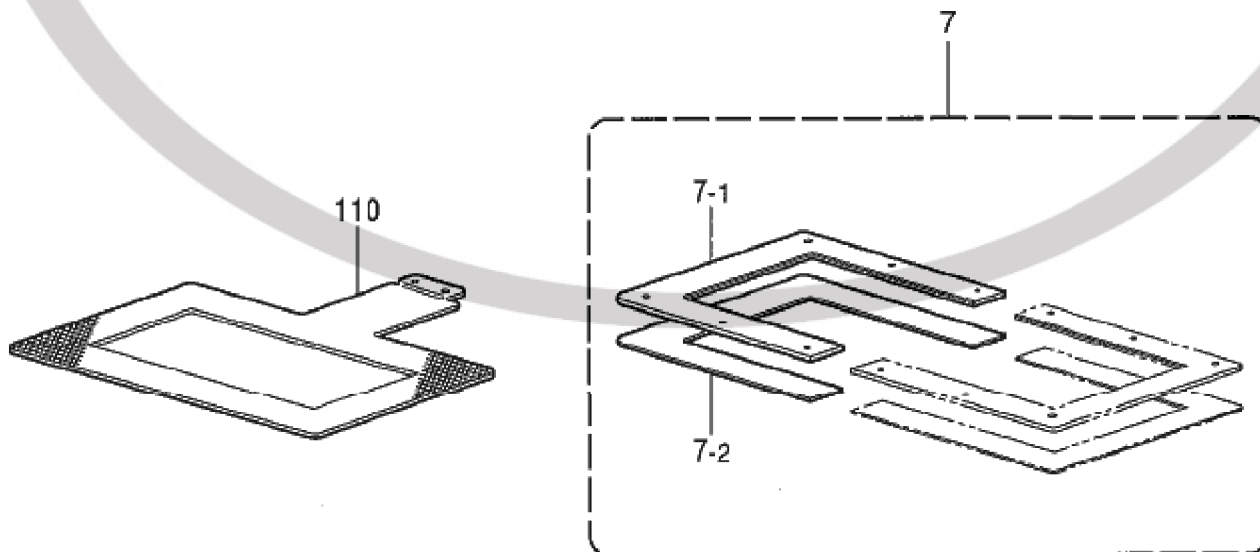
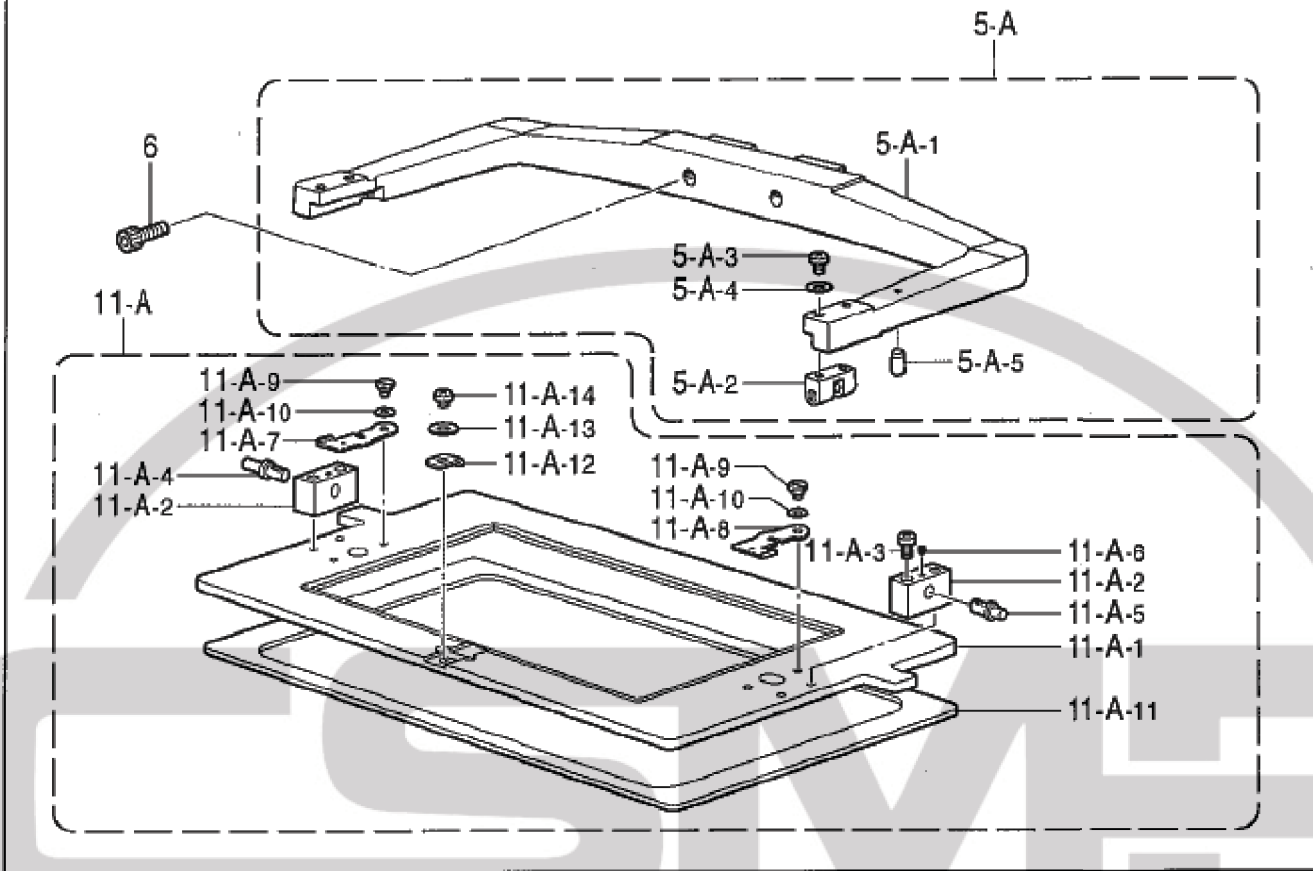

C3. 送り関係 (BAS-341F : オプション部品) / Feed mechanism (BAS-341F : Option parts)

REF.NO	CODE	Q'TY	ヒンメイ	NAME OF PARTS	RM
			" エアー式UNタイプ押え" <縫製エリア250X150mm>	"UN work clamp (Pneumatic type)" <Sewing area : 250X150mm>	
5-1	S19609009	1	オエアUNLクミ	WORK CLAMP ASSY, UNL	
5-1-1	S19610009	1	オエアUNL	WORK CLAMP, UNL	
5-1-2	S17829001	2	ヒンジクサエ	SHAFT SUPPORT	
5-1-3	062681412	4	ハコ437-40X14	SCREW, PAN SM4.37-40X14	
5-1-4	100645003	4	サガネ	WASHER	
5-1-5	104832001	2	ゴムセ10.7	RUBBER CAP, 10.7	
6	018502522	2	アホホ5X25	BOLT, SOCKET M5X25	
11-1	S47102101	1	341オエアUNLクミ	WORK CLAMP PLATE ASSY, UNL 341	
11-1-1	S48620001	1	オエアUNL	WORK CLAMP PLATE, UNL	
11-1-2	S17836001	2	オエアヒンジ	HINGE, WORK CLAMP PLATE	
11-1-3	062681612	4	ハコ437-40X16	SCREW, PAN SM4.37-40X16	
11-1-4	S17837001	1	オエアヒンジシク	HINGE SHAFT, L W-CLAMP PLATE	
11-1-5	S18014001	1	オエアヒンジシクR	HINGE SHAFT, R W-CLAMP PLATE	
11-1-6	014710522	2	アホメシ4.76ホミ	SET SCREW, SOCKET (CP) SM4.76	
11-1-7	S47103001	1	OTシヒントメクL	STOPPER, L OT-SUPPORT PIN	
11-1-8	S47104001	1	OTシヒントメクR	STOPPER, R OT-SUPPORT PIN	
11-1-9	159269001	2	シイトリリンクタンネシ	SHOULDER SCREW, SM4.37	
11-1-10	107017002	2	ナハサガネ	WAVE WASHER	
11-1-11	S19626000	1	オエアUNLクッション	CUSHION, UNL WORK CLAMP PLATE	
11-1-12	S18026001	1	アウセツタ	ADJUSTING PLATE	
11-1-13	025680232	1	ヒラサガネシウ4.37	WASHER, PLAIN M 4.37	
11-1-14	062680512	1	ハコ437-40X5	SCREW, PAN SM4.37-40X5	
			<縫製エリア180X100mm>	<Sewing area : 180X100mm>	
5-2	S19620009	1	オエアUNSクミ	WORK CLAMP ASSY, UNS	
5-2-1	S19621009	1	オエアUNS	WORK CLAMP, UNS	
5-2-2	S17829001	2	ヒンジクサエ	SHAFT SUPPORT	
5-2-3	062681412	4	ハコ437-40X14	SCREW, PAN SM4.37-40X14	
5-2-4	100645003	4	サガネ	WASHER	
5-2-5	104832001	2	ゴムセ10.7	RUBBER CAP, 10.7	
6	018502522	2	アホホ5X25	BOLT, SOCKET M5X25	
11-2	S47105001	1	341オエアUNSクミ	WORK CLAMP PLATE ASSY, UNS 341	
11-2-1	S19612001	1	オエアUNS	WORK CLAMP PLATE, UNS	
11-2-2	S17836001	2	オエアヒンジ	HINGE, WORK CLAMP PLATE	
11-2-3	062681612	4	ハコ437-40X16	SCREW, PAN SM4.37-40X16	
11-2-4	S17837001	1	オエアヒンジシク	HINGE SHAFT, L W-CLAMP PLATE	
11-2-5	S18014001	1	オエアヒンジシクR	HINGE SHAFT, R W-CLAMP PLATE	
11-2-6	014710522	2	アホメシ4.76ホミ	SET SCREW, SOCKET (CP) SM4.76	
11-2-7	S47103001	1	OTシヒントメクL	STOPPER, L OT-SUPPORT PIN	
11-2-8	S47104001	1	OTシヒントメクR	STOPPER, R OT-SUPPORT PIN	
11-2-9	159269001	2	シイトリリンクタンネシ	SHOULDER SCREW, SM4.37	
11-2-10	107017002	2	ナハサガネ	WAVE WASHER	
11-2-11	S19613000	1	オエアUNSクッション	CUSHION, UNS WORK CLAMP PLATE	
11-2-12	S18026001	1	アウセツタ	ADJUSTING PLATE	
11-2-13	025680232	1	ヒラサガネシウ4.37	WASHER, PLAIN M 4.37	
11-2-14	062680512	1	ハコ437-40X5	SCREW, PAN SM4.37-40X5	
			" 左右分離型"	"Separate type"	
7	S48617001	2	341オエアクミ	WORK CLAMP ASSY, C 341	
7-1	S48618001	2	341オエア	WORK CLAMP, C 341	
7-2	S48619000	2	341オエアクッション	CUSHION, 341 WORK CLAMP	
110	S47137101	1	オエア	FEED PLATE, A	

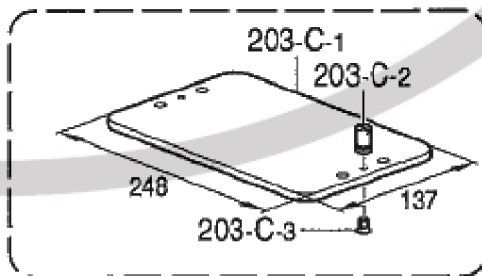
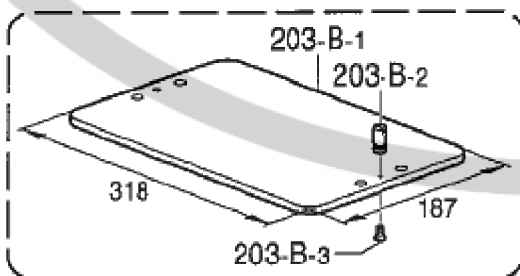
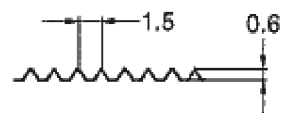
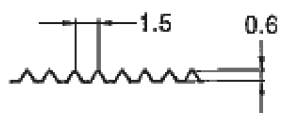
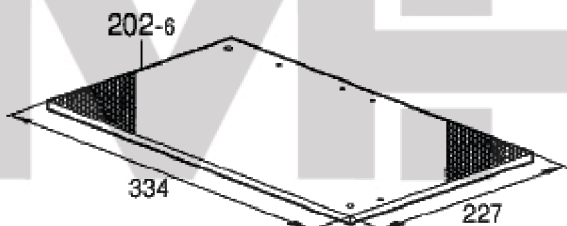
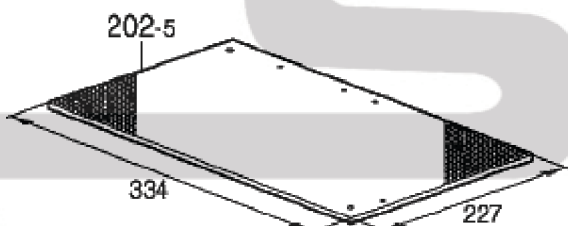
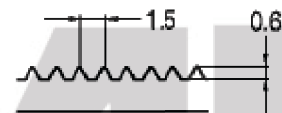
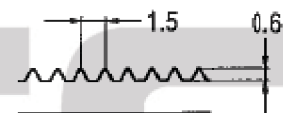
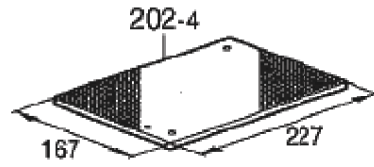
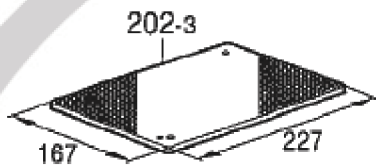
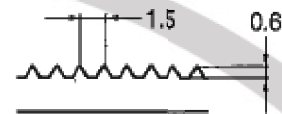
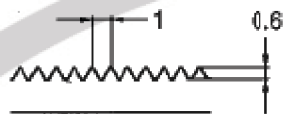
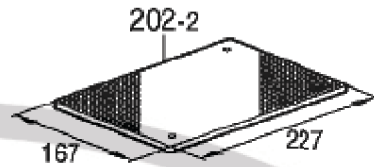
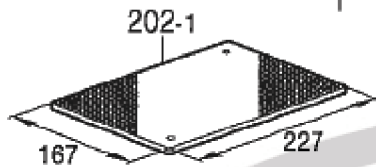
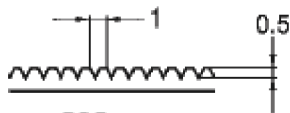
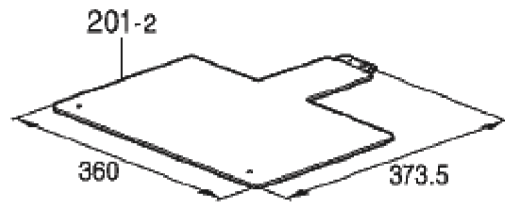
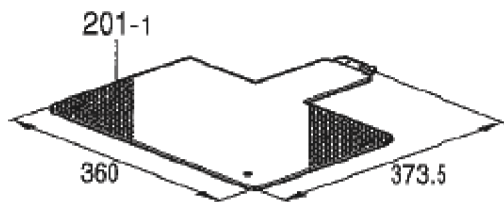

< B=1 : t=4.0,
B=2 : t=3.0,
B=3 : t=2.0 >

< C=4 : t=4.0,
C=5 : t=3.0,
C=6 : t=2.0 >

203-B

203-C

< D=7 : t=0.5,
D=8 : t=1.0,
D=9 : t=2.0 >

< E=10 : t=0.5,
E=11 : t=1.0,
E=12 : t=2.0 >

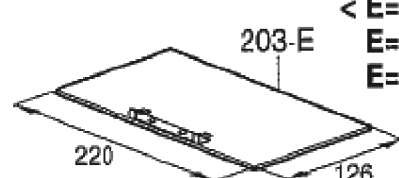
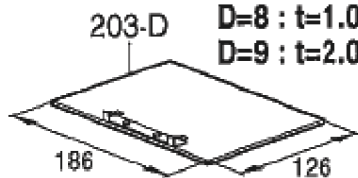

203-D

203-E

C4. 送り関係 (BAS-341F : オプション部品) / Feed mechanism (BAS-341F : Option parts)

REF.NO	CODE	QTY	品名	NAME OF PARTS	RM
			<送り板用アタッチメント>	<For feed plate attachment>	
201-1	S47612001	1	オクリイブランクA (t=1.0)	FEED PLATE BLANK, A T=1.0 (t=1.0)	
201-2	S47613001	1	オクリイブランクC (t=1.0)	FEED PLATE BLANK, C (t=1.0)	
			<押工用ブランク材>	<The blank for work clamp>	
202-1	S17979001	1	オIブランクE-1 (t=3.2)	WORK CLAMP BLANK, E-1 T=3.2 (t=3.2)	
202-2	S17981001	1	オIブランクE-4 (t=6.0)	WORK CLAMP BLANK, E-4 T=6.0 (t=6.0)	
202-3	S19599001	1	オIブランクL (t=4.0)	WORK CLAMP BLANK, L T=4.0 (t=4.0)	
202-4	S19600001	1	オIブランクR (t=4.0)	WORK CLAMP BLANK, R T=4.0 (t=4.0)	
202-5	S21723001	1	オIブランクUN-1 (t=3.2)	WORK CLAMP BLANK, UN-1 T=3.2 (t=3.2)	
202-6	S21724001	1	オIブランクUN-2 (t=4.0)	WORK CLAMP BLANK, UN-2 T=4.0 (t=4.0)	
			"ワンタッチ押工用"	"For One-touch work clamp assy"	
			<縫製エリア250X150mm>	<Sewing area : 250X150mm>	
203-1	S47168001	1	OTオI4クミ (t=4.0)	OT-WORK CLAMP ASSY, 4 (t=4.0)	
203-1-1	S17983000	1	OTオI4	OT-WORK CLAMP, 4	
203-1-2	S47169001	2	OTオIイタジピン	PIN, ONE-TOUCH	
203-1-3	S01696001	2	ラネジ 3.57X6	SCREW, FLAT SM3.57X6	
203-2	S47170001	1	OTオI3クミ (t=3.0)	OT-WORK CLAMP ASSY, 3 (t=3.0)	
203-2-1	S19593000	1	OTオI3	OT-WORK CLAMP, 3	
203-2-2	S47169001	2	OTオIイタジピン	PIN, ONE-TOUCH	
203-2-3	S01696001	2	ラネジ 3.57X6	SCREW, FLAT SM3.57X6	
203-3	S47171001	1	OTオI2クミ (t=2.0)	OT-WORK CLAMP ASSY, 2 (t=2.0)	
203-3-1	S19595000	1	OTオI2	OT-WORK CLAMP, 2	
203-3-2	S47169001	2	OTオIイタジピン	PIN, ONE-TOUCH	
203-3-3	S01696001	2	ラネジ 3.57X6	SCREW, FLAT SM3.57X6	
			<縫製エリア180X100mm>	<Sewing area : 180X100mm>	
203-4	S47614001	1	OTオI4クミ (t=4.0)	OT-WORK CLAMP ASSY, S4 (t=4.0)	
203-4-1	S19615000	1	OTオI4	OT-WORK CLAMP, S4	
203-4-2	S47169001	2	OTオIイタジピン	PIN, ONE-TOUCH	
203-4-3	S01696001	2	ラネジ 3.57X6	SCREW, FLAT SM3.57X6	
203-5	S47615001	1	OTオI3クミ (t=3.0)	OT-WORK CLAMP ASSY, S3 (t=3.0)	
203-5-1	S19617000	1	OTオI3	OT-WORK CLAMP, S3	
203-5-2	S47169001	2	OTオIイタジピン	PIN, ONE-TOUCH	
203-5-3	S01696001	2	ラネジ 3.57X6	SCREW, FLAT SM3.57X6	
203-6	S47616001	1	OTオI2クミ (t=2.0)	OT-WORK CLAMP ASSY, S2 (t=2.0)	
203-6-1	S19619000	1	OTオI2	OT-WORK CLAMP, S2	
203-6-2	S47169001	2	OTオIイタジピン	PIN, ONE-TOUCH	
203-6-3	S01696001	2	ラネジ 3.57X6	SCREW, FLAT SM3.57X6	
			<縫製エリア150X100mm>	<Sewing area : 150X100mm>	
203-7	S09378001	1	OTオIイタクミ150 (t=0.5)	OT-CASSETTE PLATE ASSY, A150 (t=0.5)	
203-8	S09379001	1	OTオIイタクミ150 (t=1.0)	OT-CASSETTE PLATE ASSY, B150 (t=1.0)	
203-9	S09380001	1	OTオIイタクミ150 (t=2.0)	OT-CASSETTE PLATE ASSY, C150 (t=2.0)	
			<縫製エリア180X100mm>	<Sewing area : 180X100mm>	
203-10	S13695001	1	OTオIイタクミ180 (t=0.5)	OT-CASSETTE PLATE ASSY, A180 (t=0.5)	
203-11	S13697001	1	OTオIイタクミ180 (t=1.0)	OT-CASSETTE PLATE ASSY, B180 (t=1.0)	
203-12	S13698001	1	OTオIイタクミ180 (t=2.0)	OT-CASSETTE PLATE ASSY, C180 (t=2.0)	

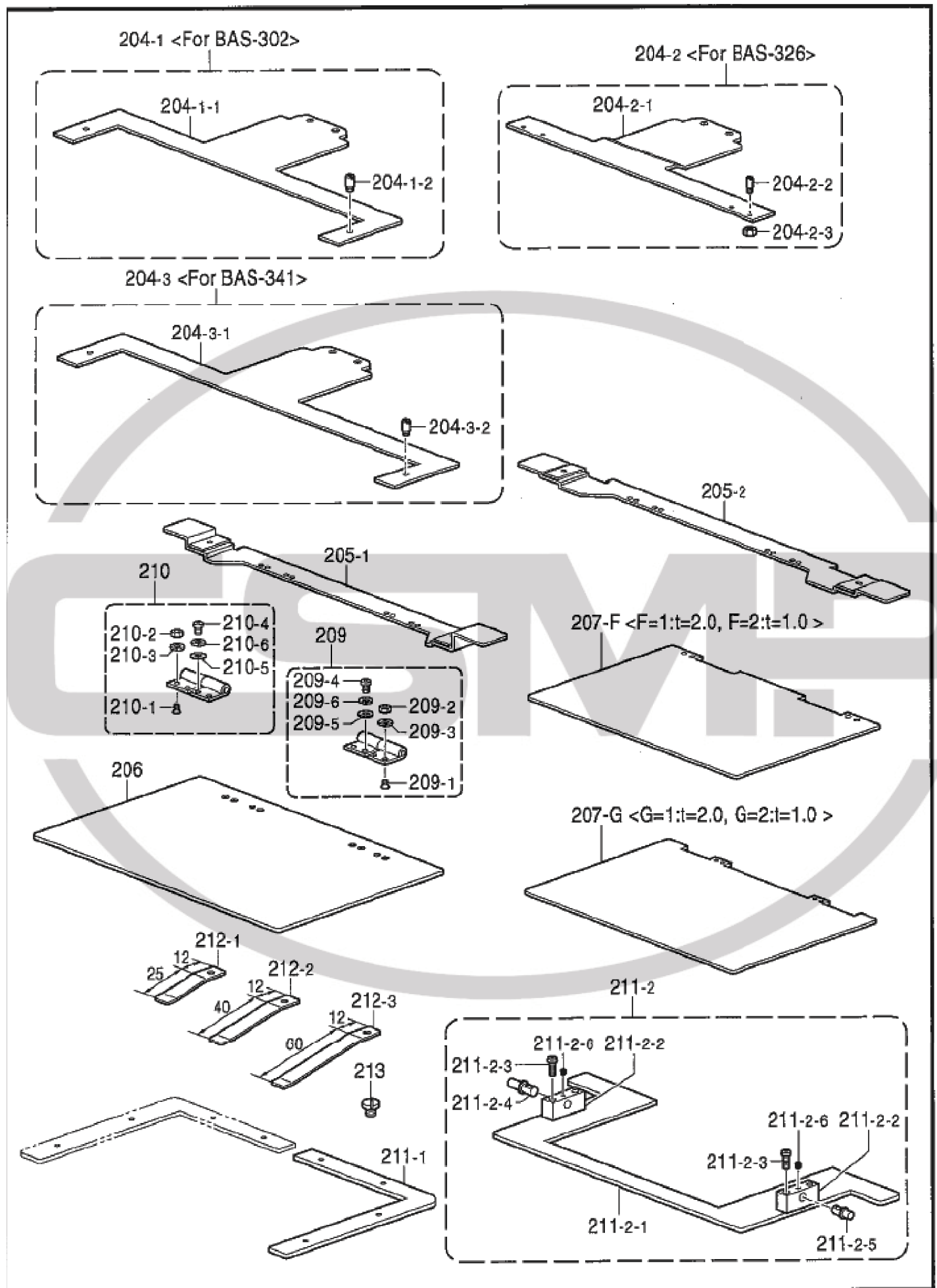

C5. 送り関係 (BAS-341F : オプション部品) / Feed mechanism (BAS-341F : Option parts)

REF.NO	CODE	Q'TY	ヒンメイ	NAME OF PARTS	RM
204-1	S47617001	1	<BAS-302用> カセットホルダプレート	<For BAS-302> CASSETTE HOLDER PLATE ASSY	
204-1-1	S47618001	1	カセットホルダプレート	HOLDER PLATE, CASSETTE	
204-1-2	S19629001	2	カセットホルダピン	PIN, C-HOLDER	
204-2	S47619001	1	<BAS-326用> カセットホルダプレート	<For BAS-326> C-HOLDER PLATE ASSY, 326	
204-2-1	S47620001	1	カセットホルダプレート	HOLDER PLATE, 326 CASSETTE	
204-2-2	S13007001	2	カセットホルダピン	PIN, CASSETTE HOLDER	
204-2-3	021660306	2	3号ナット	NUT, 3 SM3.18-40	
204-3	S47621001	1	<BAS-341用> カセットホルダプレート	<For BAS-341> C-HOLDRE PLATE ASSY, 341L	
204-3-1	S47622001	1	カセットホルダプレート	HOLDER PLATE, 341L CASSETTE	
204-3-2	S19629001	2	カセットホルダピン	PIN, C-HOLDER	
205-1	S19630001	1	カセットプレート	CASSETTE PLATE	
205-2	S20755001	1	カセットプレート	CASSETTE PLATE, 340L	
206	S19631000	1	カセット下プレート	LOWER PLATE, CASSETTE	
207-1	S19632000	1	カセット内プレート-2 (t=2.0)	INNER PLATE, 2 T=2.0 CASSETTE (t=2.0)	
207-2	S19643000	1	カセット内プレート-1 (t=1.0)	INNER PLATE, 1 T=1.0 CASSETTE (t=1.0)	
208-1	S19633000	1	カセット上プレート-2 (t=2.0)	UPPER PLATE, 2 T=2.0 CASSETTE (t=2.0)	
208-2	S19644000	1	カセット上プレート-1 (t=1.0)	UPPER PLATE, 1 T=1.0 CASSETTE (t=1.0)	
209	152632001	1	カセットヒンジ	HINGE ASSY, R	
209-1	S06696004	2	フラットネジ	SCREW, FLAT M3X6	
209-2	021300103	2	ナット	NUT, 1 M3	
209-3	028030243	2	ワッシャー	WASHER, SPRING 2-3	
209-4	062300503	2	ネジ	SCREW, PAN M3X5	
209-5	025030133	2	ワッシャー	WASHER, PLAIN S 3	
209-6	028030243	2	ワッシャー	WASHER, SPRING 2-3	
210	152633001	1	カセットヒンジ	HINGE ASSY, L	
210-1	S06696004	2	フラットネジ	SCREW, FLAT M3X6	
210-2	021300103	2	ナット	NUT, 1 M3	
210-3	028030243	2	ワッシャー	WASHER, SPRING 2-3	
210-4	062300503	2	ネジ	SCREW, PAN M3X5	
210-5	025030133	2	ワッシャー	WASHER, PLAIN S 3	
210-6	028030243	2	ワッシャー	WASHER, SPRING 2-3	
211-1	S19634001	1	ワーククランププレート	WORK CLAMP PLATE, C-1	
211-2	S19914001	1	"エア式UNタイプ押え" <縫製エリア200X100mm>	"UN work clamp (Pneumatic type)" <Sewing area : 200X100mm>	
211-2-1	S19915001	1	ワーククランププレート	WORK CLAMP PLATE ASSY, C-2	
211-2-2	S17836001	2	ワーククランププレートヒンジ	HINGE, WORK CLAMP PLATE	
211-2-3	062681612	4	ネジ	SCREW, PAN SM4.37-40X16	
211-2-4	S17837001	1	ワーククランププレートヒンジシャフト	HINGE SHAFT, L W-CLAMP PLATE	
211-2-5	S18014001	1	ワーククランププレートヒンジシャフト	HINGE SHAFT, R W-CLAMP PLATE	
211-2-6	014710522	2	ソケット	SET SCREW, SOCKET (CP) SM4.76	
212-1	S02853001	1	ワーククランププレートスプリング	SPRING, PLATE 1 C-1 (t=0.4)	
212-2	S02854001	1	ワーククランププレートスプリング	SPRING, PLATE 2 C-1 (t=0.6)	
212-3	S02855001	1	ワーククランププレートスプリング	SPRING, PLATE 3 C-1 (t=0.8)	
213	107419002	1	ネジ	SCREW, SM4.37	

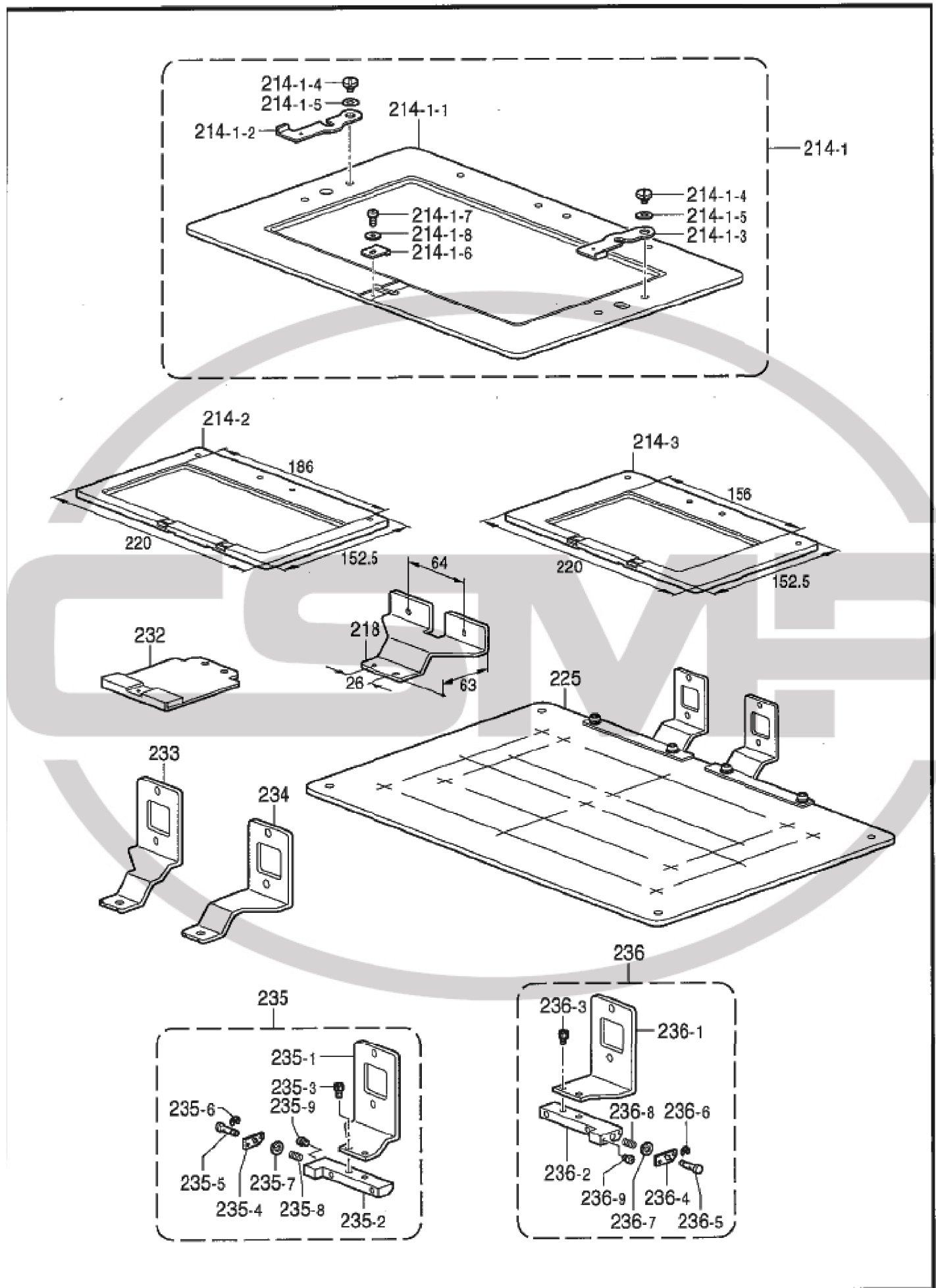

C6. 送り関係 (BAS-341F : オプション部品) / Feed mechanism (BAS-341F : Option parts)

REF.NO	CODE	QTY	ヒンメイ	NAME OF PARTS	RM
			<縫製エリア250X150mm>	<Sewing area : 250X150mm>	
214-1	S47623001	1	オISEU250X150クミ	WORK CLAMP ASSY, SEU 250X150	
214-1-1	S19636001	1	オISEU250X150	WORK CLAMP, SEU 250X150	
214-1-2	S47103001	1	OTジビ ^ン トメ ^ク L	STOPPER, L OT-SUPPORT PIN	
214-1-3	S47104001	1	OTジビ ^ン トメ ^ク R	STOPPER, R OT-SUPPORT PIN	
214-1-4	159269001	2	シャイトリリング ^ク ンネジ ^ク	SHOULDER SCREW, SM4.37	
214-1-5	107017002	2	ナハ ^ク ネ ^ク ガ ^ク ネ	WAVE WASHER	
214-1-6	S18026001	1	アヨセ ^ク ク ^ク イ ^ク	ADJUSTING PLATE	
214-1-7	025680232	1	ヒラサ ^ク ガ ^ク ネ ^ク 1/4, 37	WASHER, PLAIN M 4.37	
214-1-8	062680512	1	ナ ^ク コ ^ク 437-40X5	SCREW, PAN SM4.37-40X5	
			<縫製エリア180X100mm>	<Sewing area : 180X100mm>	
214-2	S19637001	1	オISEU180X100	WORK CLAMP, SEU 180X100	
			<縫製エリア150X100mm>	<Sewing area : 150X100mm>	
214-3	S19638001	1	オISEU150X100	WORK CLAMP, SEU 150X100	
218	S20756001	1	オIア ^ク SEU	WORK CLAMP, SEU	
			<ゲージ部品>	<For Gauge parts>	
225	S32035001	1	ケン ^ク ネ ^ク ジ ^ク ン ^ク イ ^ク ク ^ク ミ	H-POSITION STANDARD PLATE ASSY	*
232	S47624001	1	オクリイ ^ク トリ ^ク ツ ^ク ク ^ク タイ	FEED PLATE SEETING BRACKET	
233	S34156001	1	オIア ^ク SEL-326	WORK CLAMP, SEL-326	
234	S34157001	1	オIア ^ク SER-326	WORK CLAMP, SER-326	
235	S34158001	1	OTオIア ^ク SELク ^ク ミ	OT-WORK CLAMP ASSY, SEL	
235-1	S34159001	1	OTオIア ^ク SEL	OT-WORK CLAMP, SEL	
235-2	S20282001	1	オIア ^ク ホル ^ク ダ ^ク -L	WORK CLAMP HOLDER, L	
235-3	018680822	2	アホ ^ク ホ ^ク ト ^ク 4.37X8	BOLT, SOCKET SM4.37X8	
235-4	S20283001	1	サイド ^ク プレート	SIDE PLATE	
235-5	S20284001	1	イ ^ク キ ^ク 北 ^ク ン	POSITIONING PIN	
235-6	048030342	1	トメ ^ク ク ^ク E3	RETAINING RING, E3	
235-7	047140850	1	ス ^ク リング ^ク ピン ^ク 1.4X8	PIN, SPRING ROLL 1.4X8	
235-8	S20285001	1	イ ^ク キ ^ク 北 ^ク ン ^ク ハ ^ク ネ	SPRING	
235-9	062300612	2	ナ ^ク コ ^ク 3X6	SCREW, PAN M3X6	
236	S34160001	1	OTオIア ^ク SERク ^ク ミ	OT-WORK CLAMP ASSY, SER	
236-1	S34161001	1	OTオIア ^ク SER	OT-WORK CLAMP, SER	
236-2	S20288001	1	オIホル ^ク ダ ^ク -R	WORK CLAMP HOLDER, R	
236-3	018680822	2	アホ ^ク ホ ^ク ト ^ク 4.37X8	BOLT, SOCKET SM4.37X8	
236-4	S20283001	1	サイド ^ク プレート	SIDE PLATE	
236-5	S20284001	1	イ ^ク キ ^ク 北 ^ク ン	POSITIONING PIN	
236-6	048030342	1	トメ ^ク ク ^ク E3	RETAINING RING, E3	
236-7	047140850	1	ス ^ク リング ^ク ピン ^ク 1.4X8	PIN, SPRING ROLL 1.4X8	
236-8	S20285001	1	イ ^ク キ ^ク 北 ^ク ン ^ク ハ ^ク ネ	SPRING	
236-9	062300612	2	ナ ^ク コ ^ク 3X6	SCREW, PAN M3X6	

151-V41-202

RM欄に * が付いている部品は、精密な組立調整がしてありますので絶対に分解しないでください。
Parts which have an asterisk * in the RM column are parts which have been assembled and adjusted to high precisions.
These parts should never be disassembled.

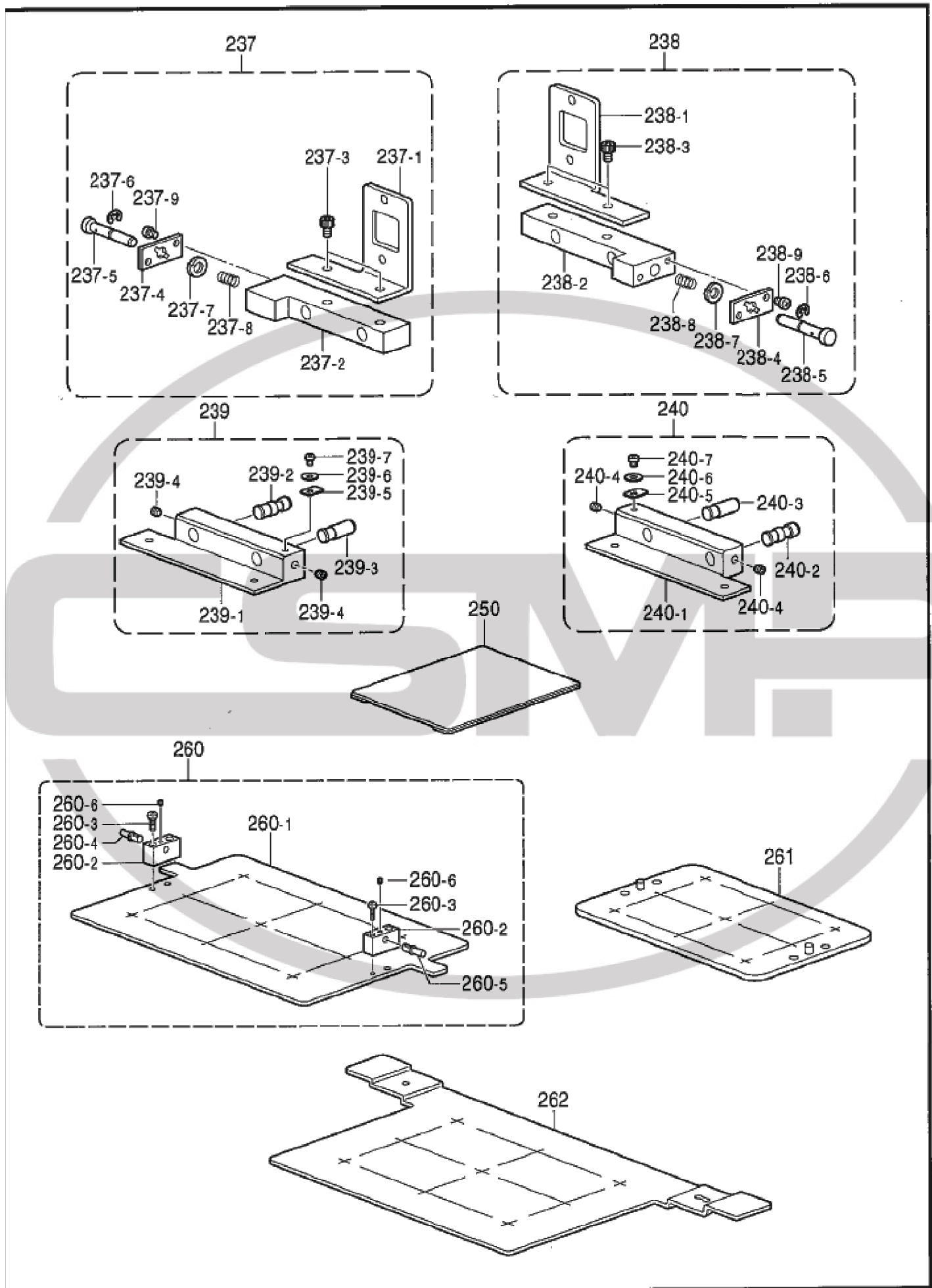

C7. 送り関係 (BAS-341F : オプション部品) / Feed mechanism (BAS-341F : Option parts)

REF.NO	CODE	QTY	ヒンメイ	NAME OF PARTS	RM
237	S34162001	1	LOTホールドクミ	(L) OT-WORK CLAMP ASSY, L	
237-1	S34163001	1	LOTホールド	(L) OT-WORK CLAMP, L	
237-2	S34166001	1	LOTホールドホルダ	(L) OT-WORK CLAMP HOLDER, L	
237-3	018501222	2	ボルトM5X12	BOLT, SOCKET M5X12	
237-4	S34169001	1	サイドプレート	SIDE PLATE	
237-5	S34168001	1	位置ピン	POSITIONING PIN	
237-6	048030342	1	留環E3	RETAINING RING, E3	
237-7	047140850	1	スプリングピン1.4X8	PIN, SPRING ROLL 1.4X8	
237-8	S20285001	1	位置ピンバネ	SPRING	
237-9	062300612	2	ネジM3X6	SCREW, PAN M3X6	
238	S34164001	1	LOTホールドクミ	(L) OT-WORK CLAMP ASSY, R	
238-1	S34165001	1	LOTホールド	(L) OT-WORK CLAMP, R	
238-2	S34167001	1	LOTホールドホルダ	(L) OT-WORK CLAMP HOLDER, R	
238-3	018501222	2	ボルトM5X12	BOLT, SOCKET M5X12	
238-4	S34169001	1	サイドプレート	SIDE PLATE	
238-5	S34168001	1	位置ピン	POSITIONING PIN	
238-6	048030342	1	留環E3	RETAINING RING, E3	
238-7	047140850	1	スプリングピン1.4X8	PIN, SPRING ROLL 1.4X8	
238-8	S20285001	1	位置ピンバネ	SPRING	
238-9	062300612	2	ネジM3X6	SCREW, PAN M3X6	
239	S34170001	1	LOTホルダクミ	(L) OT-HOLDER ASSY, L	
239-1	S34172001	1	LOTホルダ	(L) OT-HOLDER, L	
239-2	S34174001	1	位置スタッド	POSITIONING STUD	
239-3	S34175001	1	ガイドシャフト	GUIDE SHAFT	
239-4	S23651001	2	セットネジM6X6	SET SCREW, SOCKET (FT) M6X6	
239-5	S33722001	1	調整プレート	ADJUSTING PLATE	
239-6	025350134	1	ワッシャーS3.5	WASHER, PLAIN S 3.5	
239-7	062670616	1	ネジSM3.57-40X6	SCREW, PAN SM3.57-40X6	
240	S34171001	1	LOTホルダクミ	(L) OT-HOLDER ASSY, R	
240-1	S34173001	1	LOTホルダ	(L) OT-HOLDER, R	
240-2	S34174001	1	位置スタッド	POSITIONING STUD	
240-3	S34175001	1	ガイドシャフト	GUIDE SHAFT	
240-4	S23651001	2	セットネジM6X6	SET SCREW, SOCKET (FT) M6X6	
240-5	S33722001	1	調整プレート	ADJUSTING PLATE	
240-6	025350134	1	ワッシャーS3.5	WASHER, PLAIN S 3.5	
240-7	062670616	1	ネジSM3.57-40X6	SCREW, PAN SM3.57-40X6	
250	S47139009	1	フィーダカバー	FEED PLATE COVER	
260	S47601001	1	ヒンジサポートジグ41	HINGE SUPPORT JIG ASSY, 341	
260-1	S47602001	1	ヒンジサポートジグ	HINGE SUPPORT JIG, 341	
260-2	S17836001	2	ヒンジプレート	HINGE, WORK CLAMP PLATE	
260-3	062681612	4	ネジSM4.37-40X16	SCREW, PAN SM4.37-40X16	
260-4	S17837001	1	ヒンジシャフトL	HINGE SHAFT, L W-CLAMP PLATE	
260-5	S18014001	1	ヒンジシャフトR	HINGE SHAFT, R W-CLAMP PLATE	
260-6	014710522	2	セットネジSM4.76	SET SCREW, SOCKET (CP) SM4.76	
261	S47603001	1	ヒンジサポートジグ41	JIG ASSY, WORK CLAMP (UN) 341	
262	S47606001	1	ヒンジサポートプレート41	JIG, CASSETTE HOLDER PLATE 341	

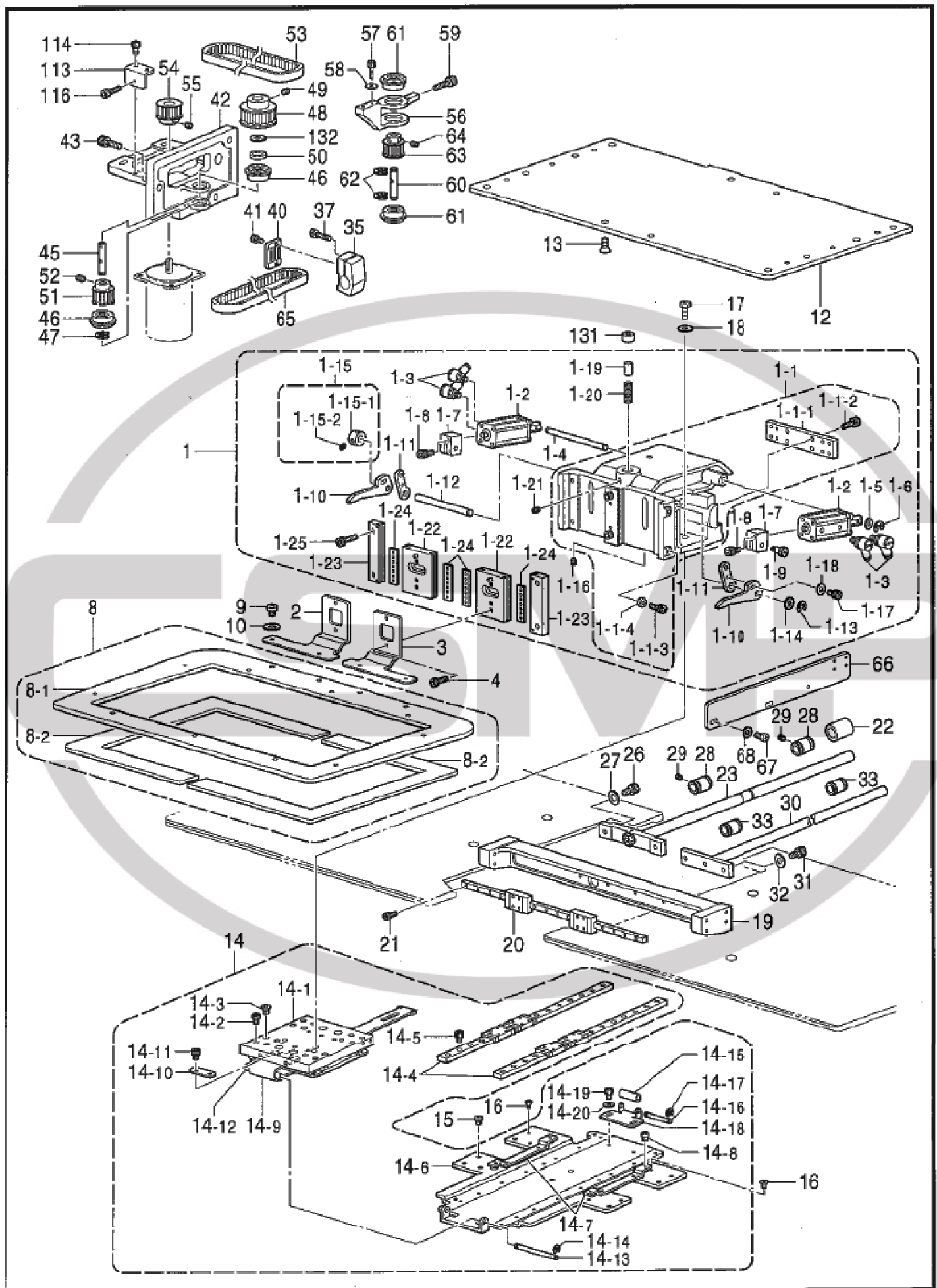

C8. 送り関係 (BAS-342F) / Feed mechanism (BAS-342F)

REF.NO	CODE	QTY	ヒンメイ	NAME OF PARTS	RM
1	SA1511001	1	オIEWテソクミ342M	WORK CLAMP ARM UNIT, 342M	
1-1	SA1482001	1	オIEWテクミ342M	WORK CLAMP ARM ASSY, 342M	
1-1-1	SA1471001	1	スライダ-レンケツイタ	SLIDER CONNECTING PLATE	
1-1-2	018401436	4	アホ-ト4X14	BOLT, SOCKET M4X14	
1-1-3	018401436	4	アホ-ト4X14	BOLT, SOCKET M4X14	
1-1-4	021400216	4	2シユナツト4	NUT, 2 M4	
1-2	S30950000	2	フラツトシリンダ	FLAT CYLINDER	
1-3	S55533000	4	ELホ-M5	ELBOW, M5	
1-4	S30948001	1	エアシリンダサエシク	AIR CYLINDER SUPPORT SHAFT	
1-5	146354001	2	サカネ	WASHER, PLAIN 5	
1-6	048040342	2	トメ7E4	RETAINING RING, E4	
1-7	S30951001	2	シリンダツキテ	CYLINDER JOINT	
1-8	018401622	2	アホ-ト4X16	BOLT, SOCKET M4X16	
1-9	110168001	2	コロシク	ROLLER SHAFT	
1-10	S17812001	2	オIEWアテレバ-U	KNEE LIFTER LIFTING LEVER, U	
1-11	S17813001	2	オIEWアテレバ-D	LEVER, D	
1-12	S17814001	1	オIEWアテシテンシク	KNEE LIFTER LIFTING SHAFT	
1-13	048050342	1	トメ7E5	RETAINING RING, E5	
1-14	143591001	1	スラストリング	THRUST RING	
1-15	S21775001	1	セツカ-クミ	SET SCREW COLLAR ASSY	
1-15-1	139096001	1	セツカ-	SET SCREW COLLAR	
1-15-2	014680422	2	アトメシ 4. 37ホミ	SET SCREW, SOCKET (CP) SM4.37	
1-16	014760622	1	アトメシ 5. 95	SET SCREW, SOCKET SM5.95	
1-17	018400832	2	アホ-ト4X8	BOLT, SOCKET M4X8	
1-18	025040132	2	ヒラサガネヨウ4	WASHER, PLAIN S 4	
1-19	S17816001	1	スライダ-サエシク	SUPPORT SHAFT, SLIDER	
1-20	S18636101	1	スライダ-オシホネ	SPRING	
1-21	014760622	1	アトメシ 5. 95	SET SCREW, SOCKET SM5.95	
1-22	S17817009	2	オIEWアシクミ	WORK CLAMP ASSY	
1-23	S17809009	2	オIEWアアンナイクミ	WORK CLAMP GUIDE ASSY	
1-24	S17823100	4	オIEWアリテ-ナクミ	WORK CLAMP RETAINER ASSY	
1-25	018501622	4	アホ-ト5X16	BOLT, SOCKET M5X16	
2	S17825001	1	オIEWアSEL	WORK CLAMP, SE L	
3	S17826001	1	オIEWアSER	WORK CLAMP, SE R	
4	018501222	2	アホ-ト5X12	BOLT, SOCKET M5X12	
8	SA1512001	1	342オIEWクミ	WORK CLAMP ASSY, 342	
8-1	SA0697000	1	342オIEW	WORK CLAMP, 342	
8-2	S48623000	2	342オIEWクッション	CUSHION, 342 WORK CLAMP	
9	153057102	4	オIEWリイタシメネシ	SCREW, ROUND W/SOCKET SM4.37	
10	025680232	4	ヒラサガネヨウ4. 37	WASHER, PLAIN M 4.37	
12	SA0689001	1	オIEWアサエシク342	W-CLAMP ARM SUPPORT PLATE, 342	
13	149482001	4	アツキテラホ-トM6X15	BOLT, FLAT W/SOCKET M6X15	
14	S47290201	1	V42オIEWリタイクミ	FEED BASE ASSY, V42	
14-1	S49418101	1	YオIEWリタイクミ342	Y-FEED BRACKET ASSY, 342	
14-2	S47307001	14	シメネシ 3X4	SCREW, M3X4	
14-3	004300513	2	オIEWサコ3X5	SCREW, FLAT M3X5	
14-4	S47292000	2	342リニアガイド-Y	LINEAR GUIDE, Y 342	
14-5	018300532	18	アホ-ト3X5	BOLT, SOCKET M3X5	
14-6	S47293101	1	342オIEWリタイク	FEED BRACKET, X 342	
14-7	S47327001	2	Xカバー-スペース-サ342	COVER SPACER, X-COVER	
14-8	062300412	4	オIEWコ3X4	SCREW, PAN M3X4	
14-9	S47311000	1	オIEWウシンベルト	CONCEAL BELT	
14-10	S47321001	2	ベルトオIEWイタ	BELT SUPPORT PLARE	
14-11	018400532	4	アホ-ト4X5	BOLT, SOCKET M4X5	
14-12	S47312001	1	ベルトローラ-F	BELT ROLLER, F	
14-13	S47313001	1	ベルトローラ-F	SHAFT, F BELT ROLLER	
14-14	048030342	2	トメ7E3	RETAINING RING, E3	
14-15	S47314001	1	ベルトローラ-R	BELT ROLLER, R	
14-16	S47315001	1	ベルトローラ-R	SHAFT, R BELT ROLLER	
14-17	048030342	2	トメ7E3	RETAINING RING, E3	

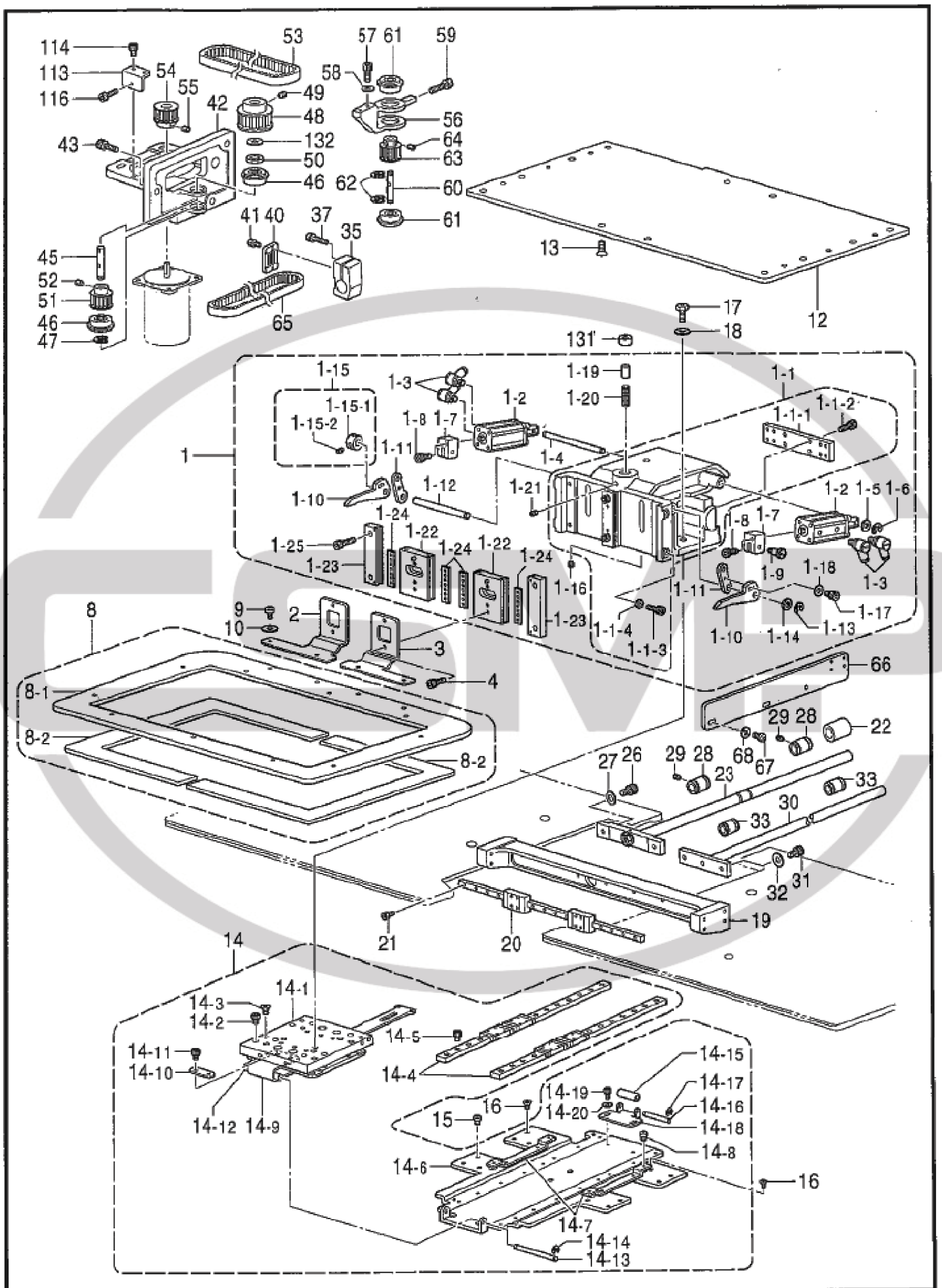

C8. 送り関係 (BAS-342F) / Feed mechanism (BAS-342F)

REF.NO	CODE	QTY	ヒンメイ	NAME OF PARTS	RM
14-18	S47316001	1	ロ-ラン'クR#4	SUPPORTER, SHAFT (R)	
14-19	018400822	2	アホ'ト4X8	BOLT, SOCKET M4X8	
14-20	025040132	2	ヒラサ'ガ'ネヨウ4	WASHER, PLAIN S 4	
15	062300512	14	ハ'コ3X5	SCREW, PAN M3X5	
16	061300616	2	サコ3X6	SCREW, FLAT M3X6	
17	018061622	2	アホ'ト6X16	BOLT, SOCKET M6X16	
18	025060132	2	ヒラサ'ガ'ネヨウ6	WASHER, PLAIN S 6	
19	SA0684000	1	Xオクリール'サI342	X-FEED RAIL SUPPORT, 342	
20	SA0685001	1	Xオクリール'ア'イト	X-FEED LINEAR GUIDE	
21	018300836	11	アホ'ト3X8	BOLT, SOCKET M3X8	
22	S47165000	1	リアフ'ツシスリ-フ'	SLEEVE, LINEAR BUSH	
23	S47111101	1	Yクト'ウシ'クミ	Y-DRIVING SHAFT ASSY	
26	018501022	2	アホ'ト5X10	BOLT, SOCKET M5X10	
27	S03677001	2	サ'カ'ネ	WASHER	
28	S47112000	2	リアフ'ツシI16	LINEAR BUSH, 16	
29	014680422	2	アトメシ'4. 37カ'ミ	SET SCREW, SOCKET (CP) SM4.37	
30	S47113001	1	Yクト'ア'ン'ナシ'ク	Y-DRIVING GUIDE SHAF	
31	018501022	2	アホ'ト5X10	BOLT, SOCKET M5X10	
32	S03677001	2	サ'カ'ネ	WASHER	
33	S10103001	2	ホ'-ル'フ'ツシ	BALL BUSH	
35	SA0696001	1	Yクト'ウシ'クホル'ダ'	Y-DRIVING SHAFT HOLDER	
37	018062022	1	アホ'ト6X20	BOLT, SOCKET M6X20	
40	SA0694001	1	Y'ホ'ルトホル'ダ'	Y-BELT HOLDER	
41	018680822	2	アホ'ト4. 37X8	BOLT, SOCKET SM4.37X8	
42	S47116001	1	Yクト'カ'Pモ-タ'ブ'ラ'ツ'ト	P-MOTOR BRACKET, Y-DRIVING	
43	018082022	3	アホ'ト8X20	BOLT, SOCKET M8X20	
45	S47119001	1	Yフ'-リ'シ'ク'フ	Y-PULLEY SHAFT, F	
46	076000850	2	タ'シ'ク'ウ'ケ6000ZZNR	BALL BEARING, 6000ZZNR	
47	048080342	1	ト'メ'フ'エ8	RETAINING RING, E8	
48	SA0752001	1	アイ'ド'ル'フ'-リ342	IDLE PULLEY, 342	
49	014770622	2	アトメシ'6. 35カ'ミ	SET SCREW, SOCKET (CP) SM6.35	
50	156070002	1	ス'パ'-サ	SPACER	
51	SA0750001	1	タイ'ミン'グ'フ'-リ342	TIMING PULLEY, 342	
52	014770622	2	アトメシ'6. 35カ'ミ	SET SCREW, SOCKET (CP) SM6.35	
53	SA0749000	1	モ-タ'フ'ト'ル'ト342	MOTOR TIMING BELT, 342	
54	SA0751001	1	モ-タ'フ'ト'ル'ト342	MOTOR TIMING PULLEY, 342	
55	014770622	2	アトメシ'6. 35カ'ミ	SET SCREW, SOCKET (CP) SM6.35	
56	S47122000	1	Yフ'-リ'タ'イ	Y-PULLEY BRACKET	
57	018502522	2	アホ'ト5X25	BOLT, SOCKET M5X25	
58	025050232	2	ヒラサ'ガ'ネ'ユ'ウ5	WASHER, PLAIN M 5	
59	018503022	1	アホ'ト5X30	BOLT, SOCKET M5X30	
60	S47123001	1	Yフ'-リ'シ'ク'フ'R	Y-PULLEY SHAFT, R	
61	076000850	2	タ'シ'ク'ウ'ケ6000ZZNR	BALL BEARING, 6000ZZNR	
62	048080342	2	ト'メ'フ'エ8	RETAINING RING, E8	
63	SA0750001	1	タイ'ミン'グ'フ'-リ342	TIMING PULLEY, 342	
64	014770622	2	アトメシ'6. 35カ'ミ	SET SCREW, SOCKET (CP) SM6.35	
65	SA0748000	1	Yタイ'ミン'グ'フ'-リ342	Y-TIMING BELT, 342	
66	S47125001	1	Yセン'サ-トリ'ツ'ケ'イ'タ'	Y-SENSOR SETTING PLATE	
67	062680812	2	ハ'コ437-40X8	SCREW, PAN SM4.37-40X8	
68	025680232	2	ヒラサ'ガ'ネ'ユ'ウ4. 37	WASHER, PLAIN M 4.37	
113	S47173001	1	Y. T'フ'ト'ル'ト'ユ'ウ'セ'イ'タ'	Y-TIMING BELT ADJUSTING PLATE	
114	018501022	2	アホ'ト5X10	BOLT, SOCKET M5X10	
116	018502522	1	アホ'ト5X25	BOLT, SOCKET M5X25	
131	S17815000	1	スライ'ダ'-	SLIDER	
132	025100132	1	ヒラサ'ガ'ネ'ユ'ウ10	WASHER, PLAIN S 10	

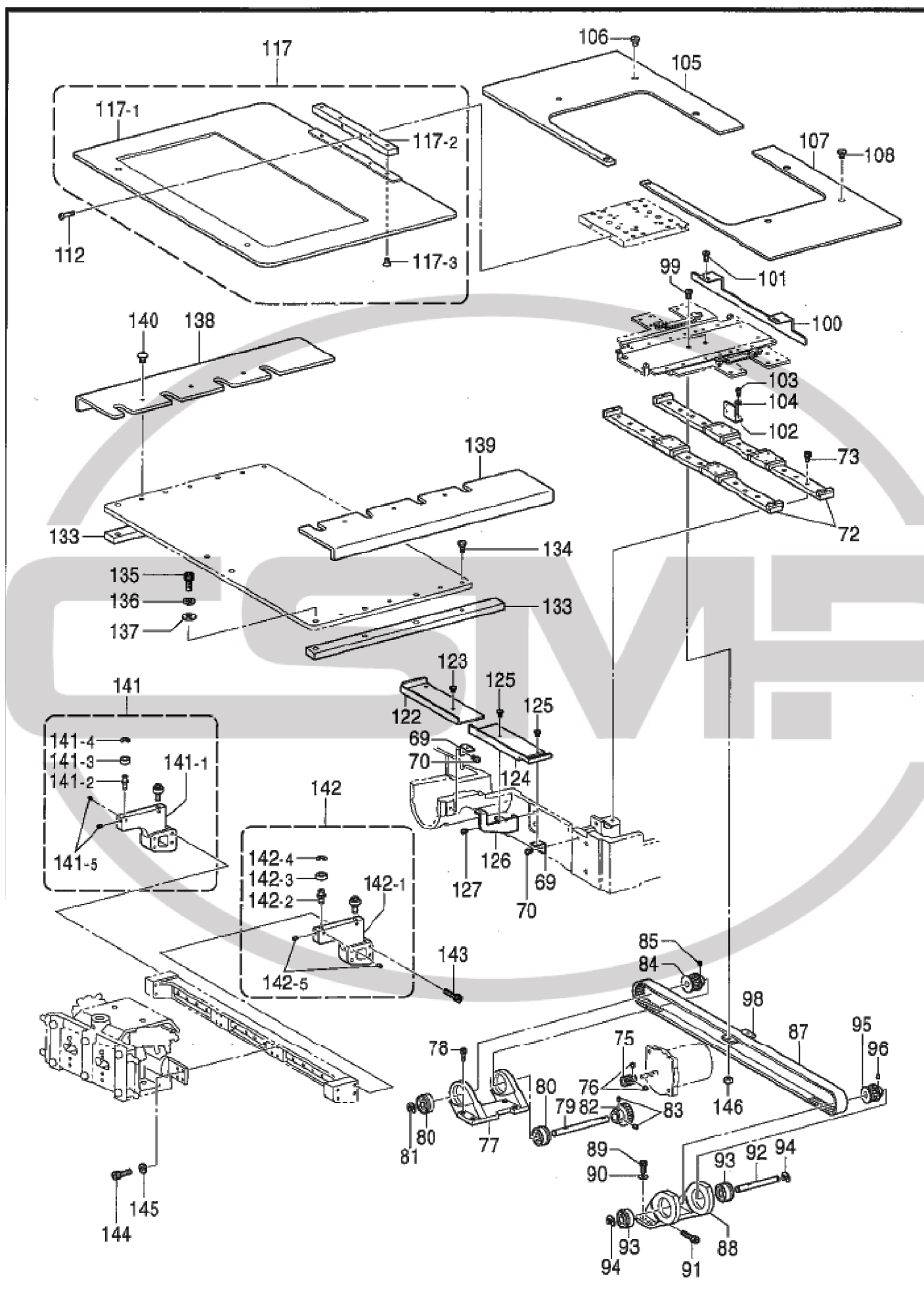

C9. 送り関係 (BAS-342F) / Feed mechanism (BAS-342F)

REF.NO	CODE	QTY	ヒンメイ	NAME OF PARTS	RM
69	S10091201	4	ルイ殊ジヨイササエ	AUXILIARY PLATE SUPPORT	
70	060680712	4	ハ ^レ イント ^ク 437-40X7	SCREW, BIND SM4.37-40X7	
72	S47298000	2	Xリニアカ ^ク イ ^ク 342	X-LINEAR GUIDE, 342	
73	018401036	9	アホ ^レ ルト4X10	BOLT, SOCKET M4X10	
75	S47172001	1	外 ^ク ギ ^ク ヤ20	DRIVING GEAR, 20	
76	014760822	2	アホメジ ^ク 5.95	SET SCREW, SOCKET SM5.95	
77	S47127100	1	X ^ク リタ ^ク 4L	X-PULLEY BASE, L	
78	018501622	4	アホ ^レ ルト5X16	BOLT, SOCKET M5X16	
79	S47129001	1	X ^ク リシ ^ク 4L	X-PULLEY SHAFT, L	
80	076000850	2	タシ ^ク ク ^ク 6000ZZNR	BALL BEARING, 6000ZZNR	
81	048080342	1	トマ ^ク E8	RETAINING RING, E8	
82	S47128001	1	アイト ^ク ギ ^ク 32	IDLER GEAR, 32	
83	014770622	2	アホメジ ^ク 6.35 ^ク ホ ^ク ミ	SET SCREW, SOCKET (CP) SM6.35	
84	SA0750001	1	タイミン ^ク プ ^ク リ342	TIMING PULLEY, 342	
85	014770622	2	アホメジ ^ク 6.35 ^ク ホ ^ク ミ	SET SCREW, SOCKET (CP) SM6.35	
87	SA0747000	1	Xタイミン ^ク ホ ^ク ルト342	X-TIMING BELT, 342	
88	S47130100	1	X ^ク リタ ^ク 4R	X-PULLEY BRACKET, R	
89	018501622	4	アホ ^レ ルト5X16	BOLT, SOCKET M5X16	
90	025050232	4	ヒラサ ^ク ガ ^ク ネ ^ク 10 ^ク 5	WASHER, PLAIN M 5	
91	018502522	1	アホ ^レ ルト5X25	BOLT, SOCKET M5X25	
92	S47131001	1	X ^ク リシ ^ク 4R	X-PULLEY SHAFT, R	
93	076000850	2	タシ ^ク ク ^ク 6000ZZNR	BALL BEARING, 6000ZZNR	
94	048080342	2	トマ ^ク E8	RETAINING RING, E8	
95	SA0750001	1	タイミン ^ク プ ^ク リ342	TIMING PULLEY, 342	
96	014770622	2	アホメジ ^ク 6.35 ^ク ホ ^ク ミ	SET SCREW, SOCKET (CP) SM6.35	
98	SA0693001	1	X ^ク ベルト ^ク ホルダ	X-BELT HOLDER	
99	062681012	2	ナ ^ク コ437-40X10	SCREW, PAN SM4.37-40X10	
100	S49042001	1	X ^ク 軸 ^ク ホームポジション ^ク ドグ	X-AXIS HOME POSITION DOG	
101	060680712	2	ハ ^レ イント ^ク 437-40X7	SCREW, BIND SM4.37-40X7	
102	S49043001	1	Xセンサ ^ク トリツ ^ク カ ^ク イ ^ク	SETTING PLATE, X-SENSOR	
103	062680812	2	ナ ^ク コ437-40X8	SCREW, PAN SM4.37-40X8	
104	025680232	2	ヒラサ ^ク ガ ^ク ネ ^ク 10 ^ク 4.37	WASHER, PLAIN M 4.37	
105	S47300101	1	XYオクリ ^ク カバー ^ク -342L	XY-FEED COVER, L 342	
106	106629002	4	シメ ^ク ネ ^ク ジ ^ク 4.37	SCREW, SM4.37	
107	S47301101	1	XYオクリ ^ク カバー ^ク -342R	XY-FEED COVER, R 342	
108	106629002	4	シメ ^ク ネ ^ク ジ ^ク 4.37	SCREW, SM4.37	
112	150382001	2	アホ ^レ ルト4.37X18	BOLT, SOCKET SM4.37X18	
117	SA1513001	1	342オクリ ^ク イ ^ク タ ^ク ン ^ク ク ^ク ミ	FEED PLATE N ASSY, 342	
117-1	SA0698001	1	342オクリ ^ク イ ^ク タ ^ク ン ^ク ク ^ク ミ	FEED PLATE, N :342	
117-2	SA0699001	1	オクリ ^ク イ ^ク タ ^ク ン ^ク ク ^ク ミ	FEED PLATE SUPPORT, 342	
117-3	004401014	4	ナ ^ク コ4X10	SCREW, FLAT M4X10	
122	S49044001	1	オクリ ^ク カバー ^ク -L	FEED COVER, L	
123	106629002	2	シメ ^ク ネ ^ク ジ ^ク 4.37	SCREW, SM4.37	
124	S49045001	1	オクリ ^ク カバー ^ク -R	FEEDCOVER, R	
125	106629002	2	シメ ^ク ネ ^ク ジ ^ク 4.37	SCREW, SM4.37	
126	S47306101	2	サ ^ク イ ^ク イ ^ク BLR	SUPPORT PLATE, BL R	
127	062680812	4	ナ ^ク コ437-40X8	SCREW, PAN SM4.37-40X8	
133	SA0690001	2	ガイ ^ク イト ^ク コロ ^ク レ ^ク ル	GUIDE ROLLER RAIL	
134	S35324001	2	タ ^ク ン ^ク ネ ^ク ジ ^ク M4	SHOULDER SCREW, M4	
135	018061636	6	アホ ^レ ルト6X16	BOLT, SOCKET M6X16	
136	028060246	6	ハ ^レ ネ ^ク サ ^ク カ ^ク ネ ^ク 2-6	WASHER, SPRING 2-6	
137	025060236	6	ヒラサ ^ク ガ ^ク ネ ^ク 10 ^ク 6	WASHER, PLAIN M 6	
138	SA0691001	1	ガイ ^ク イト ^ク コロ ^ク カバー ^ク -L	GUIDE ROLLER COVER, L	
139	SA0692001	1	ガイ ^ク イト ^ク コロ ^ク カバー ^ク -R	GUIDE ROLLER COVER, R	
140	008400604	6	ナ ^ク コ4X6	SCREW, TRUSS M4X6	

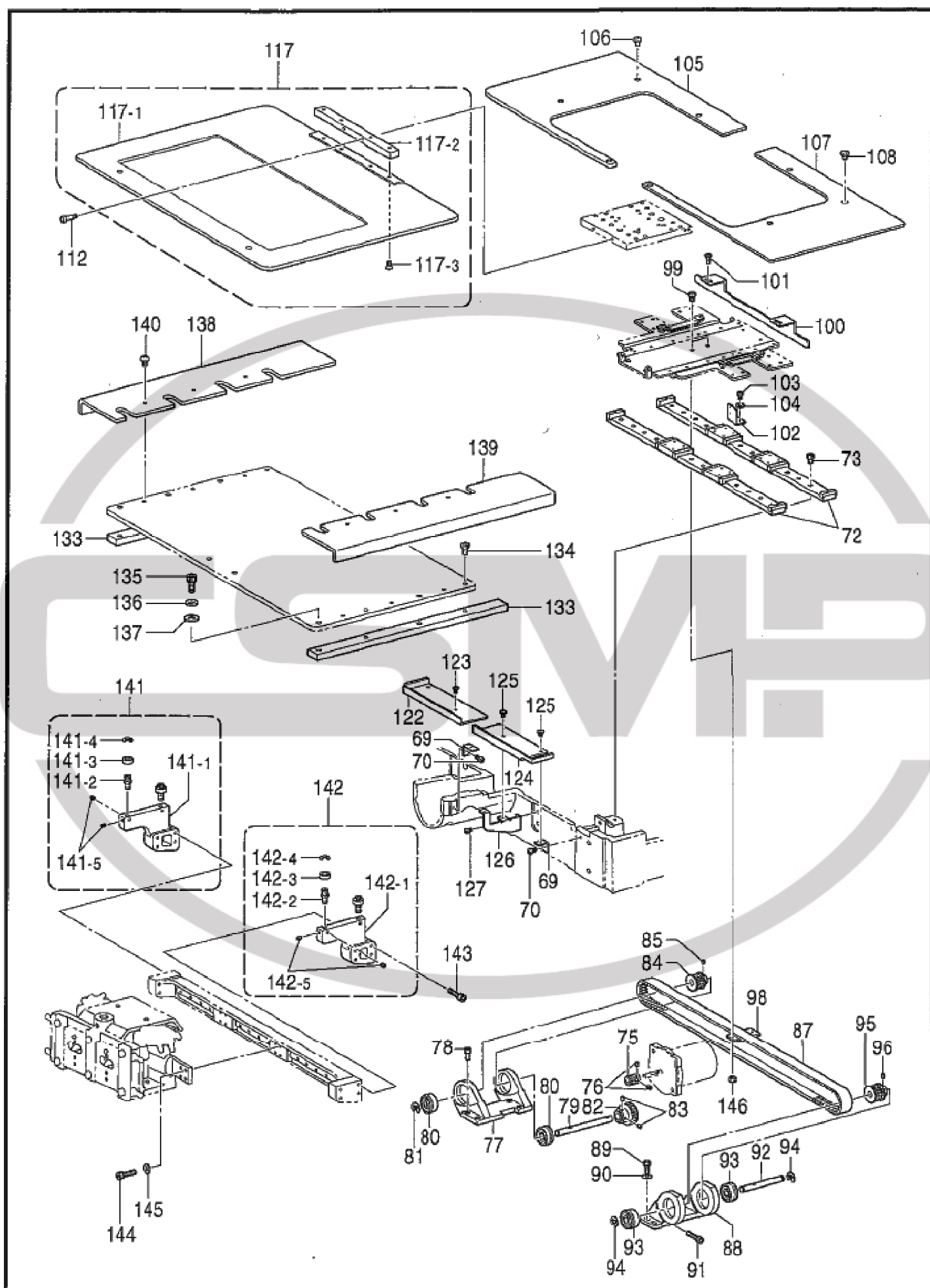

C9. 送り関係 (BAS-342F) / Feed mechanism (BAS-342F)

REF.NO	CODE	QTY	ヒンメイ	NAME OF PARTS	RM
141	SA1509001	1	ガイドコロ ^レ イ ^ク ミ	GUIDE ROLLER BASE L ASSY	
141-1	SA0686000	1	ガイドコロ ^レ イ ^ク	GUIDE ROLLER BASE, L	
141-2	SA0688001	2	ハンジツク	ECCENTRIC SHAFT	
141-3	530138001	2	マイクロ ^レ ア ^リ ンク ^レ 8	MICRO BEARING, 8	
141-4	048060342	2	トメ ^レ E6	RETAINING RING, E6	
141-5	014500522	4	ア ^ト メ ^シ ソ ^ク ホ ^ミ	SET SCREW, SOCKET (CP) M5X5	
142	SA1510001	1	ガイドコロ ^レ イ ^ク ミ	GUIDE ROLLER BASE R ASSY	
142-1	SA0687000	1	ガイドコロ ^レ イ ^ク	GUIDE ROLLER BASE, R	
142-2	SA0688001	2	ハンジツク	ECCENTRIC SHAFT	
142-3	530138001	2	マイクロ ^レ ア ^リ ンク ^レ 8	MICRO BEARING, 8	
142-4	048060342	2	トメ ^レ E6	RETAINING RING, E6	
142-5	014500522	4	ア ^ト メ ^シ ソ ^ク ホ ^ミ	SET SCREW, SOCKET (CP) M5X5	
143	018502536	8	ア ^ホ ト ^メ 5X25	BOLT, SOCKET M5X25	
144	018301036	8	ア ^ホ ト ^メ 3X10	BOLT, SOCKET M3X10	
145	028030246	8	ハ ^ネ ガ ^キ 2-3	WASHER, SPRING 2-3	
146	021680212	2	ナ ^ツ 2 ^メ 4.37	NUT, 2 SM4.37	

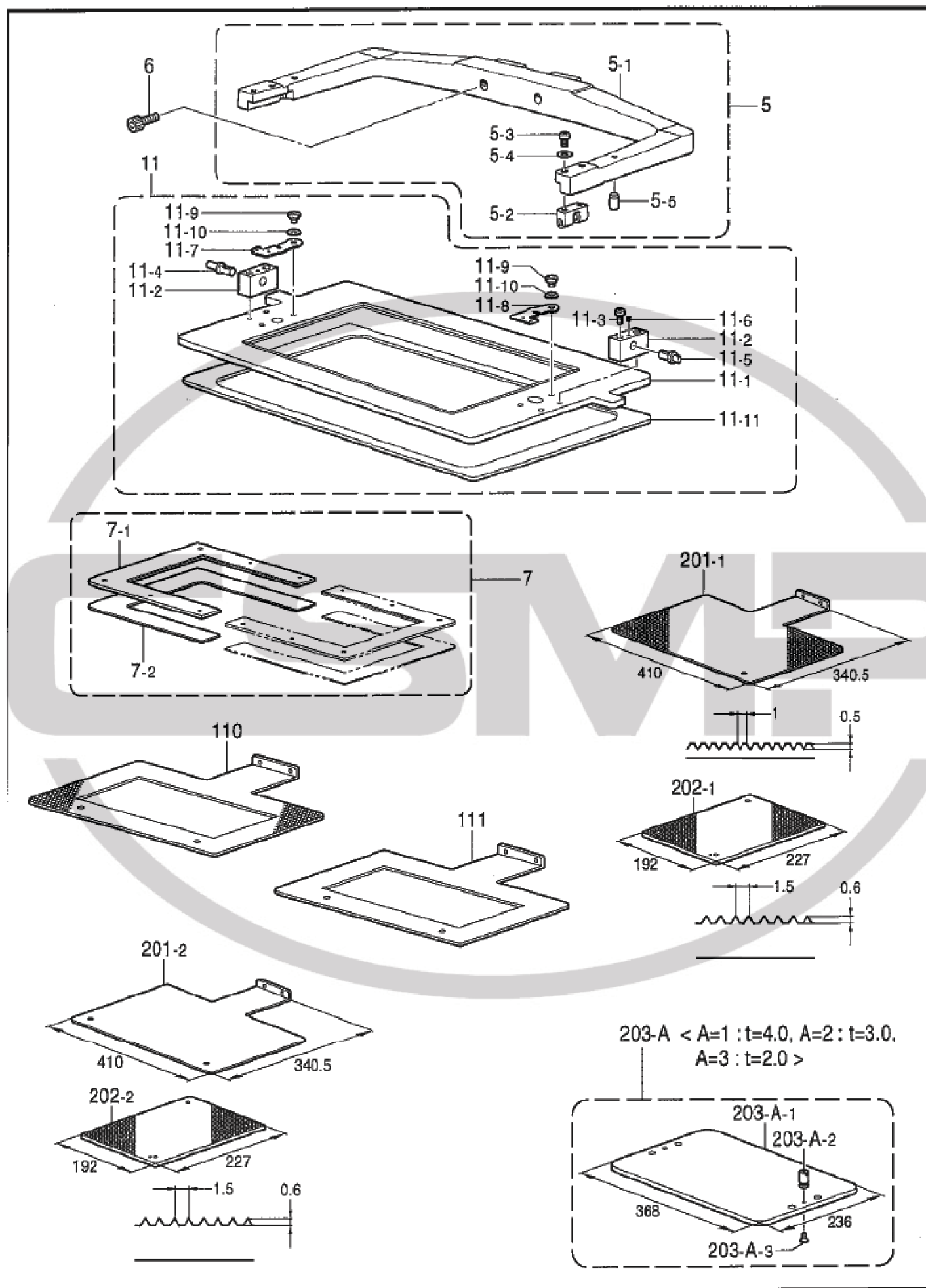

C10. 送り関係 (BAS-342F : オプション部品) / Feed mechanism (BAS-342F : Option parts)

REF.NO	CODE	QTY	ヒンメイ	NAME OF PARTS	RM
			" エアー式UNタイプ押え "	"UN work clamp (Pneumatic type)"	
5	S31164009	1	オアアUN300クミ	WORK CLAMP ASSY, UN 300	
5-1	S31165009	1	オアアUN300	WORK CLAMP, UN 300	
5-2	S17829001	2	ヒンジクサ	SHAFT SUPPORT	
5-3	062681412	4	ハコ437-40X14	SCREW, PAN SM4.37-40X14	
5-4	100645003	4	ワカネ	WASHER	
5-5	104832001	2	ゴム栓10.7	RUBBER CAP, 10.7	
6	018502522	2	ボルトM5X25	BOLT, SOCKET M5X25	
			" 左右分離型 "	"Separate type"	
7	S48621001	2	342材ICクミ	WORK CLAMP ASSY, C 342	
7-1	S48622001	2	342材IC	WORK CLAMP, C 342	
7-2	S48623000	2	342材ICクッション	CUSHION, 342 WORK CLAMP	
			" エアー式UNタイプ押え "	"UN work clamp (Pneumatic type)"	
11	S47289101	1	342材ICUNLクミ	WORK CLAMP PLATE ASSY, UNL 342	
11-1	S48624001	1	342材ICUN	WORK CLAMP PLATE, UN 342	
11-2	S17836001	2	オアICヒンジ	HINGE, WORK CLAMP PLATE	
11-3	062681612	4	ハコ437-40X16	SCREW, PAN SM4.37-40X16	
11-4	S17837001	1	オアICヒンジシク	HINGE SHAFT, L W-CLAMP PLATE	
11-5	S18014001	1	オアICヒンジシクR	HINGE SHAFT, R W-CLAMP PLATE	
11-6	014710522	2	オアICヒンジシク	SET SCREW, SOCKET (CP) SM4.76	
11-7	S47103001	1	OTシビノトメクL	STOPPER, L OT-SUPPORT PIN	
11-8	S47104001	1	OTシビノトメクR	STOPPER, R OT-SUPPORT PIN	
11-9	159269001	2	シボ付ワッシャー	SHOULDER SCREW, SM4.37	
11-10	107017002	2	波ワッシャー	WAVE WASHER	
11-11	S31168000	1	オアICUN300クッション	CUSHION, W-CLAMP PLATE UN	
110	S48625001	1	342材IC	FEED PLATE, A 342	
111	S48626001	1	342材IC	FEED PLATE, C 342	
			<送り板用アタッチメント>	<For feed plate attachment>	
201-1	S31256001	1	オアICランクA300 (t=1.0)	FEED PLATE BLANK, A-300 T=1.0 (t=1.0)	
201-2	S31257001	1	オアICランクC300 (t=1.0)	FEED PLATE BLANK, C-300 (t=1.0)	
			<押工用ブランク材>	<The blank for work clamp>	
202-1	S31244001	1	オアICランクL (t=4.0)	WORK CLAMP BLANK, L T=4.0 (t=4.0)	
202-2	S31245001	1	オアICランクR (t=4.0)	WORK CLAMP BLANK, R T=4.0 (t=4.0)	
			"ワンタッチ押工用" <縫製エリア300X200mm>	"For One-touch work clamp assy" <Sewing area : 300X200mm>	
203-1	S47302001	1	OTオアICクミ (t=4.0)	OT-WORK CLAMP ASSY, 4 (t=4.0)	
203-1-1	S30995000	1	OTオアIC(300)	OT-WORK CLAMP, 4-300	
203-1-2	S47169001	2	OTオアICヒンジ	PIN, ONE-TOUCH	
203-1-3	S01696001	2	ワッシャー 3.57X6	SCREW, FLAT SM3.57X6	
203-2	S47303001	1	OTオアICクミ (t=3.0)	OT-WORK CLAMP ASSY, 3 (t=3.0)	
203-2-1	S30997000	1	OTオアIC(300)	OT-WORK CLAMP, 3-300	
203-2-2	S47169001	2	OTオアICヒンジ	PIN, ONE-TOUCH	
203-2-3	S01696001	2	ワッシャー 3.57X6	SCREW, FLAT SM3.57X6	
203-3	S47304001	1	OTオアICクミ (t=2.0)	OT-WORK CLAMP ASSY, 2 (t=2.0)	
203-3-1	S30999000	1	OTオアIC(300)	OT-WORK CLAMP, 2-300	
203-3-2	S47169001	2	OTオアICヒンジ	PIN, ONE-TOUCH	
203-3-3	S01696001	2	ワッシャー 3.57X6	SCREW, FLAT SM3.57X6	

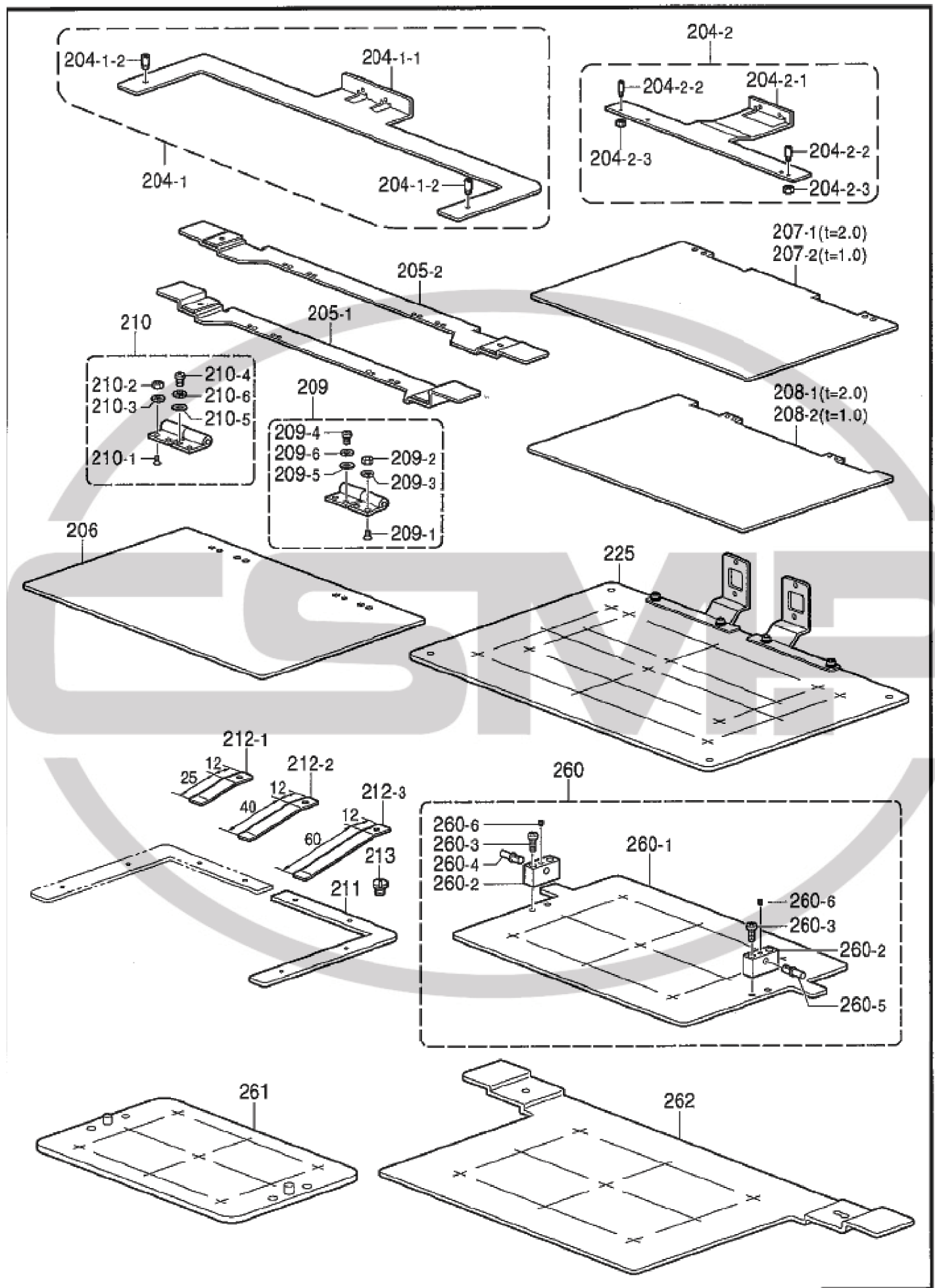

C11. 送り関係 (BAS-342F : オプション部品) / Feed mechanism (BAS-342F : Option parts)

REF.NO	CODE	QTY	品名	NAME OF PARTS	RM
204-1	S31259101	1	ホルダプレート342L	C-HOLDER PLATE ASSY, 342L	
204-1-1	S31260101	1	ホルダプレート342L	CASSETTE HOLDER PLATE, 342L	
204-1-2	S19629001	2	ホルダピン	PIN, C-HOLDER	
204-2	S33720001	1	ホルダプレートZ26	C-HOLDER PLATE ASSY, Z26	
204-2-1	S33721001	1	ホルダプレートZ26	HOLDER PLATE, Z26 CASSETTE	
204-2-2	S13007001	2	ホルダピン	PIN, CASSETTE HOLDER	
204-2-3	021660306	2	ナット3M3.18-40	NUT, 3 SM3.18-40	
205-1	S19630001	1	ホルダプレート	CASSETTE PLATE	
205-2	S31261001	1	ホルダプレート342L	CASSETTE PLATE, 342L	
206	S31262000	1	ホルダプレート	LOWER PLATE, CASSETTE	
207-1	S31263000	1	ホルダプレート2 (t=2.0)	INNER PLATE, 2 T=2.0 CASSETTE (t=2.0)	
207-2	S31264000	1	ホルダプレート1 (t=1.0)	INNER PLATE, 1 T=1.0 CASSETTE (t=1.0)	
208-1	S31265000	1	ホルダプレート2 (t=2.0)	UPPER PLATE, 2 T=2.0 CASSETTE (t=2.0)	
208-2	S31266000	1	ホルダプレート1 (t=1.0)	UPPER PLATE, 1 T=1.0 CASSETTE (t=1.0)	
209	152632001	1	ヒンジアッセンブリ	HINGE ASSY, R	
209-1	S06696004	2	ネジM3X6	SCREW, FLAT M3X6	
209-2	021300103	2	ナット1M3	NUT, 1 M3	
209-3	028030243	2	ワッシャー2-3	WASHER, SPRING 2-3	
209-4	062300503	2	ネジM3X5	SCREW, PAN M3X5	
209-5	025030133	2	ワッシャー3	WASHER, PLAIN S 3	
209-6	028030243	2	ワッシャー2-3	WASHER, SPRING 2-3	
210	152633001	1	ヒンジアッセンブリ	HINGE ASSY, L	
210-1	S06696004	2	ネジM3X6	SCREW, FLAT M3X6	
210-2	021300103	2	ナット1M3	NUT, 1 M3	
210-3	028030243	2	ワッシャー2-3	WASHER, SPRING 2-3	
210-4	062300503	2	ネジM3X5	SCREW, PAN M3X5	
210-5	025030133	2	ワッシャー3	WASHER, PLAIN S 3	
210-6	028030243	2	ワッシャー2-3	WASHER, SPRING 2-3	
211	S31273001	1	ホルダプレートC-1(300)	WORK CLAMP PLATE, C-1/300	
212-1	S02853001	1	ホルダプレート1 (t=0.4)	SPRING, PLATE 1 C-1 (t=0.4)	
212-2	S02854001	1	ホルダプレート2 (t=0.6)	SPRING, PLATE 2 C-1 (t=0.6)	
212-3	S02855001	1	ホルダプレート3 (t=0.8)	SPRING, PLATE 3 C-1 (t=0.8)	
213	107419002	1	ネジSM4.37	SCREW, SM4.37	
225	S32035001	1	<ゲージ部品> H-POSITION STANDARD PLATE ASSY	<For Gauge parts> H-POSITION STANDARD PLATE ASSY	*
260	S47607001	1	ヒンジサポートジグ42	HINGE SUPPORT JIG ASSY, 342	
260-1	S47608001	1	ヒンジサポートジグ42	HINGE SUPPORT JIG, 342	
260-2	S17836001	2	ホルダプレート	HINGE, WORK CLAMP PLATE	
260-3	062681612	4	ネジSM4.37-40X16	SCREW, PAN SM4.37-40X16	
260-4	S17837001	1	ホルダシャフトL	HINGE SHAFT, L W-CLAMP PLATE	
260-5	S18014001	1	ホルダシャフトR	HINGE SHAFT, R W-CLAMP PLATE	
260-6	014710522	2	セットネジ4.76	SET SCREW, SOCKET (CP) SM4.76	
261	S47609001	1	ヒンジアッセンブリ	JIG ASSY, WORK CLAMP (UN) 342	
262	S47611001	1	ホルダプレート	JIG, CASSETTE HOLDER PLATE 342	

151-V42-202

RM欄に * が付いている部品は、精密な組立調整がしてありますので絶対に分解しないでください。

Parts which have an asterisk * in the RM column are parts which have been assembled and adjusted to high precisions.

These parts should never be disassembled.

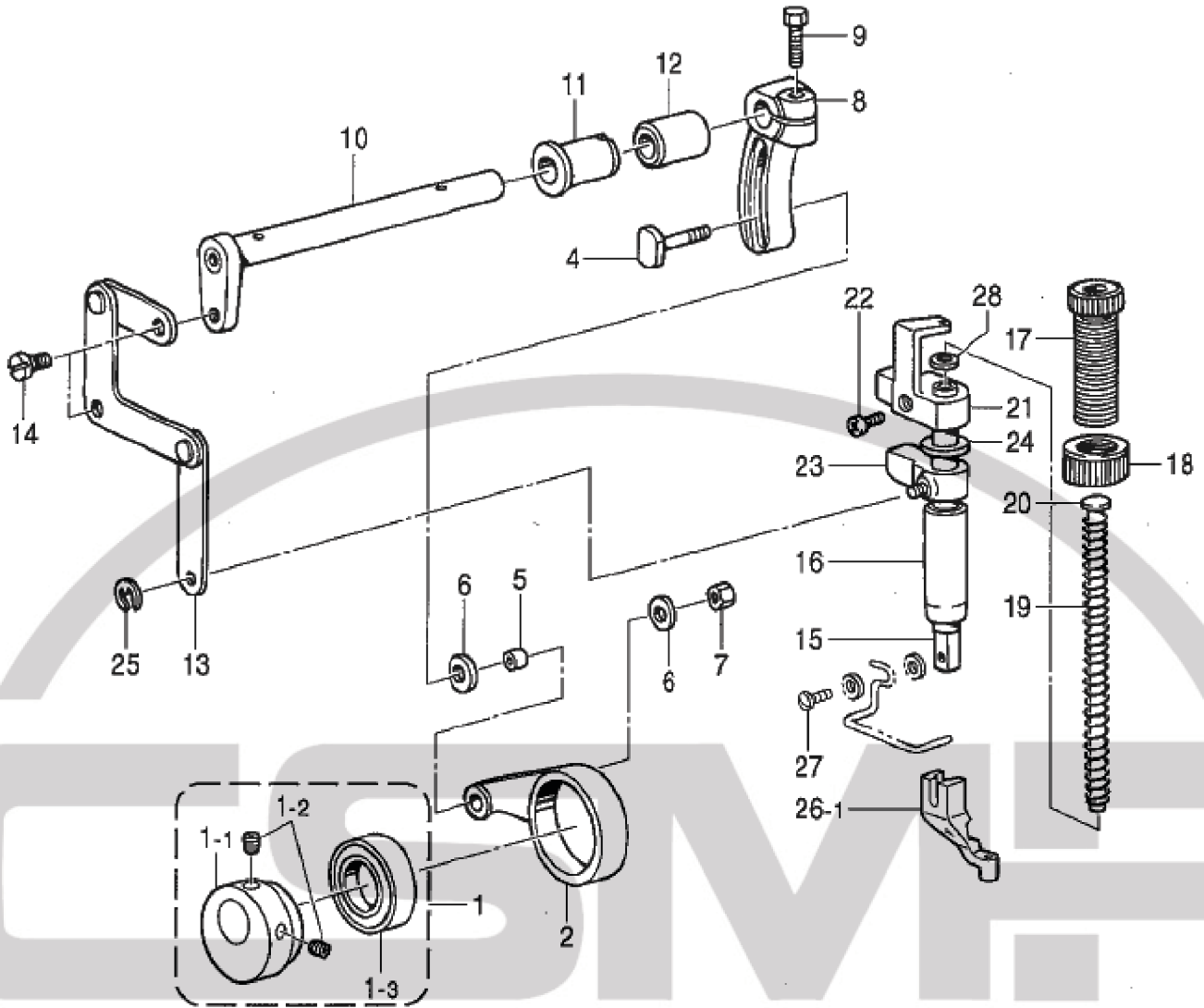

" オプション部品 / OPTION PARTS "

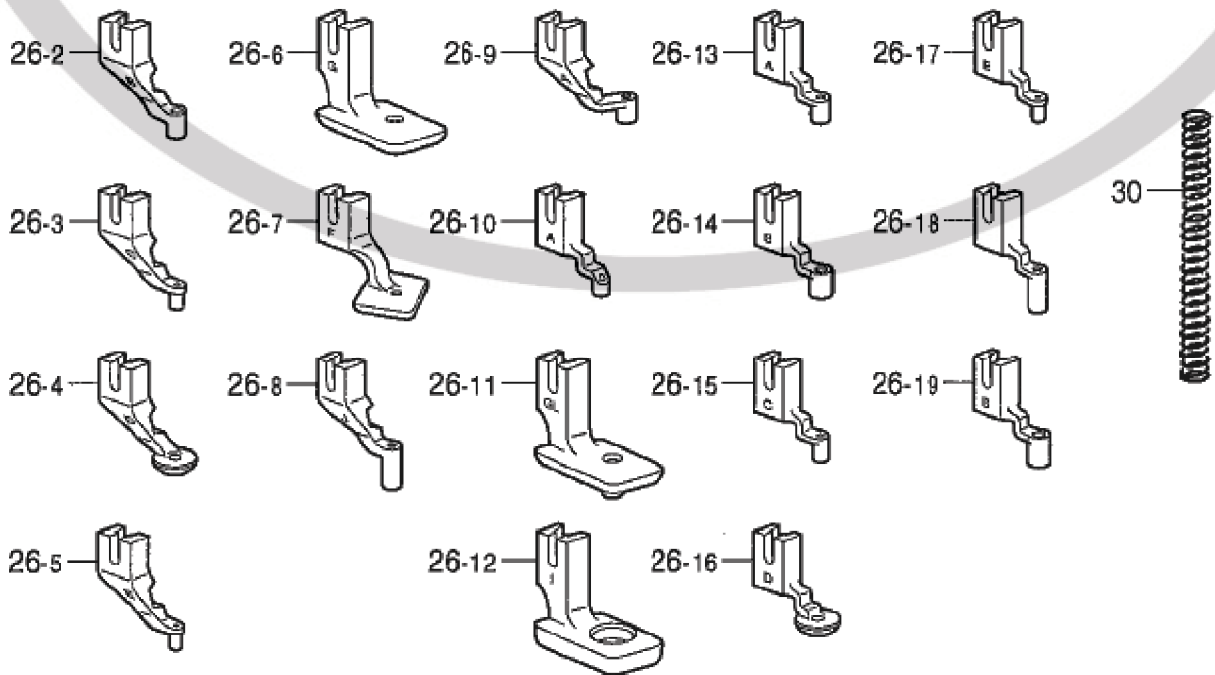

D. 押工上ゲ関係 / Work clamp lifter mechanism

REF.NO	CODE	QTY	ヒンメイ	NAME OF PARTS	RM
1	S47140001	1	カンケツツサエカム	STEPPING WORK CLAMP CAM ASSY	
1-1	S47141001	1	カンケツツサエカム	STEPPING WORK CLAMP CAM	
1-2	014760622	2	アトメネジ 5.95	SET SCREW, SOCKET SM5.95	
1-3	623033000	1	タマシクウケ6805VV	BALL BEARING, 6805VV	
2	S43693000	1	カンケツツサエレンカン	STEPPING WORK CLAMP CON. ROD	
4	150460001	1	U-UDオクリレハシク	U-UD FEED LIFTER LEVER SHAFT	
5	150461001	1	オクリ玉	FEED ROLLER	
6	107453001	2	サカネ	WASHER	
7	021750102	1	1シユナト556-32	NUT, 1 SM5.56-32	
8	S17871101	1	カンケツツサエウテ R	STEPPING WORK CLAMP ARM, R	
9	017751412	1	ボルト5.56X14	BOLT, SM5.56X14	
10	S17872101	1	カンケツツサエウテ F	STEPPING WORK CLAMP ARM, F	
11	148196000	1	ウツメサトウテメタルL	BUSH, L	
12	148197000	1	ウツメサトウテメタルR	BUSH, R	
13	S17873101	1	カンケツツリンク	STEPPING LINK ASSY	
14	155167002	2	ダンネジ 5.56	SHOULDER SCREW, SM5.56	
15	111466101	1	オサエウ	PRESSER BAR	
16	145472001	1	オサエウメタル	PRESSER BAR BUSH	
17	S31012001	1	オサエウセツネジ	PRESSER ADJUSTING SCREW	
18	S31013001	1	セツネジツマミナツ	PRESSER ADJUSTING NUT	
19	S10111101	1	オサエウネ	PRESSER BAR SPRING	
20	S10112001	1	オサエウネアライ	SPRING GUIDE	
21	S48665001	1	オサエウタキ	GUIDE BRACKET, ;P-BAR	
22	062681212	1	パネコ37-40X12	SCREW, PAN SM4.37-40X12	
23	S10371001	1	オサエウリフター	PRESSER BAR LIFTER	
24	S10372100	1	オサエウタキクッション	CUSHION	
25	048040342	1	トメワ	RETAINING RING, E4	
26-1	S42843001	1	オサエウA	PRESSER FOOT, A	
			" オプション部品 "	"OPTION PARTS"	
26-2	S42844001	1	オサエウB	PRESSER FOOT, B	
26-3	S42845001	1	オサエウC	PRESSER FOOT, C	
26-4	S42846001	1	オサエウD	PRESSER FOOT, D	
26-5	S42847001	1	オサエウE	PRESSER FOOT, E	
26-6	158592001	1	オサエウG	PRESSER FOOT, G	
26-7	157237001	1	オサエウF	PRESSER FOOT, F	
26-8	S42848001	1	オサエウJ	PRESSER FOOT, J	
26-9	S42849101	1	オサエウXA	PRESSER FOOT, XA	
26-10	S40214001	1	オサエウA-CUT	PRESSER FOOT, A-CUT	
26-11	S20864001	1	オサエウGL	PRESSER FOOT, GL	
26-12	S04887001	1	オサエウI	PRESSER FOOT, I	
26-13	152283101	1	オサエウA	PRESSER FOOT, A	
26-14	152636101	1	オサエウB	PRESSER FOOT, B	
26-15	152637001	1	オサエウC	PRESSER FOOT, C	
26-16	154069001	1	オサエウD	PRESSER FOOT, D	
26-17	154089001	1	オサエウE	PRESSER FOOT, E	
26-18	S13815001	1	オサエウJ	PRESSER FOOT, J	
26-19	S49448001	1	オサエウB-L	PRESSER FOOT, B-L	
27	S13399001	1	シメネジ 3.57X12	SCREW, SM3.57X12	
28	S03677001	1	サカネ	WASHER	
			" オプション部品 "	"OPTION PARTS"	
			<強力型>	<Strong type>	
30	S33251001	1	オサエウネ	PRESSER BAR SPRING	

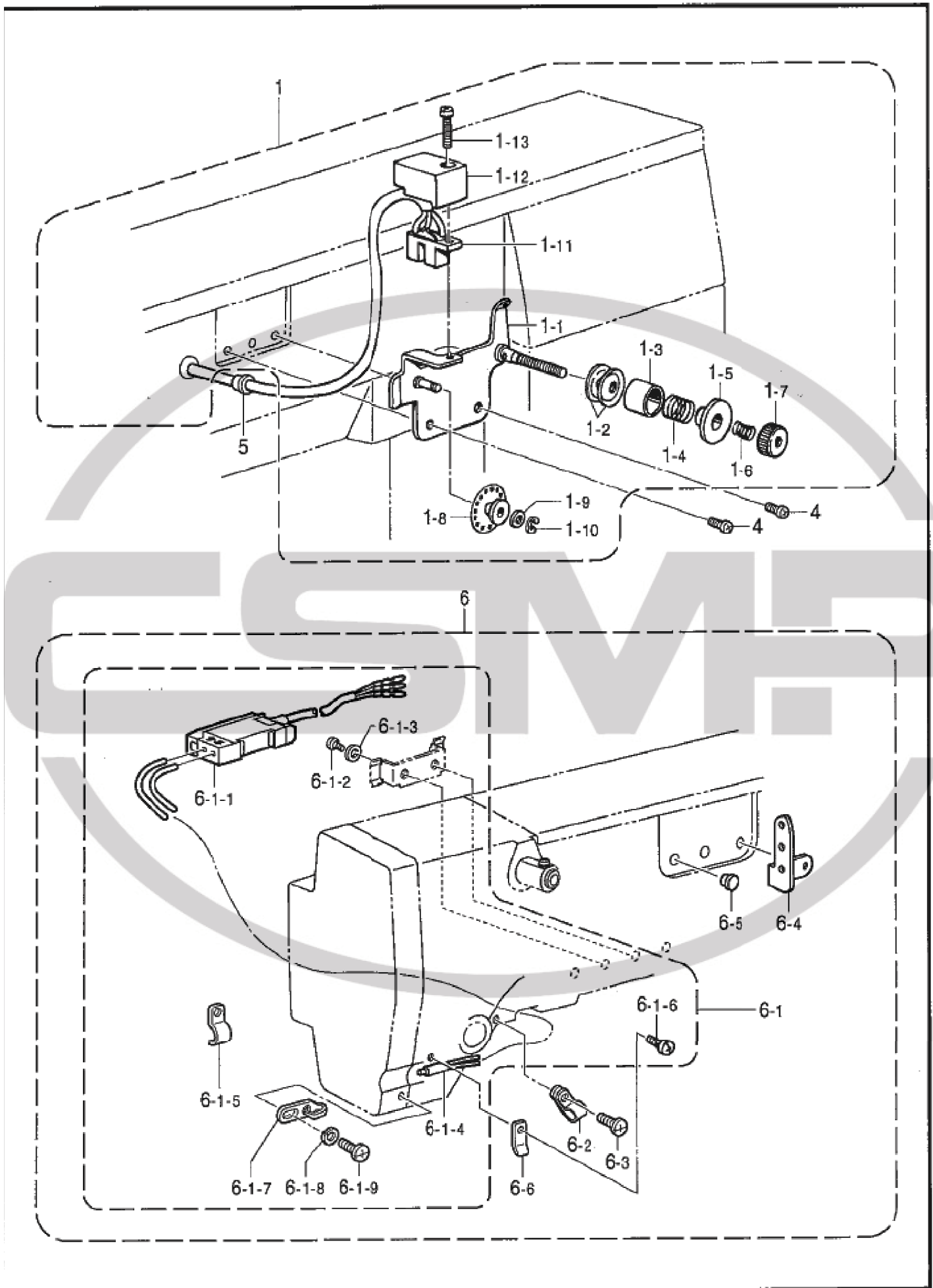

E. 糸切れ感知関係 / Thread breakage detector mechanism

REF.NO	CODE	QTY	品名	NAME OF PARTS	RM
1	S43834109	1	トータルブレーキ機構	TR. BREAKAGE DETECTOR ASSY, R	
1-1	S18032001	1	ブレーキ機構ブラケット	DETECTOR BRACKET ASSY	
1-2	144504001	2	案内ワイヤ	THREAD GUIDEDISC	
1-3	146206009	1	案内ワイヤガイド	DISC PRESSER, T-GUIDE	
1-4	146058001	1	予張りばね	PRE-TENSION SPRING	
1-5	146059001	1	予張りナット	PRE-TENSION NUT	
1-6	146060000	1	ナット	SPRING	
1-7	155510001	1	ワイヤナット	TENSION NUT	
1-8	157255100	1	プーリーA	PULLEY, A	
1-9	025030135	1	ワッシャー	WASHER, PLAIN S 3	
1-10	048020342	1	留環E2	RETAINING RING, E2	
1-11	S43835100	1	センサー機構	SENSOR ASSY	
1-12	S18037009	1	センサーカバー	SENSOR COVER	
1-13	062301616	1	ネジM3X16	SCREW, PAN M3X16	
4	062670612	2	ネジSM3.57-40X6	SCREW, PAN SM3.57-40X6	
5	146080000	1	コードブッシュ	CORD BUSH	
			"オプション部品"	"OPTION PARTS"	
			<ビームセンサー方式>	<Beam-type>	
6	S43836301	1	ブレーキ機構セットF	TR. BRAKEAGE DETECTOR SET, F	
6-1	S43977201	1	ブレーキ機構	TR. BRAKEAGE DETECTOR ASSY, F	
6-1-1	S43279300	1	増幅ユニット	AMPLIFIRE UNIT	
6-1-2	062300612	2	ネジM3X6	SCREW, PAN M3X6	
6-1-3	025030232	2	ワッシャー	WASHER, PLAIN M 3	
6-1-4	S29468100	1	ファイバユニットN	FIBER UNIT, N	
6-1-5	S11884001	1	センサー調整板	SENSOR SETTING PLATE	
6-1-6	062300612	1	ネジM3X6	SCREW, PAN M3X6	
6-1-7	S02617001	1	フェイスプレート案内	FACE PLATE THREAD GUIDE	
6-1-8	028350242	1	ワッシャー	WASHER, SPRING 2-3.5	
6-1-9	060670612	1	ネジSM3.57-40X6	SCREW, BIND SM3.57-40X6	
6-2	625010000	1	ナイロンクランプNK-2N	NYLON CLAMP NK-2N	
6-3	060670612	1	ネジSM3.57-40X6	SCREW, BIND SM3.57-40X6	
6-4	152889001	1	スレッドリテーナ	THREAD RETAINER	
6-5	117936001	2	ゴムキャップ9.4	RUBBER CAP, 9.4	
6-6	S02657101	1	コードホルダ	CORD HOLDER	

F1 . 下軸關係 / Lower shaft mechanism

< A=1 : 中厚物用 / For Medium materials >

< A=2 : 厚物用 / For Heavy materials >

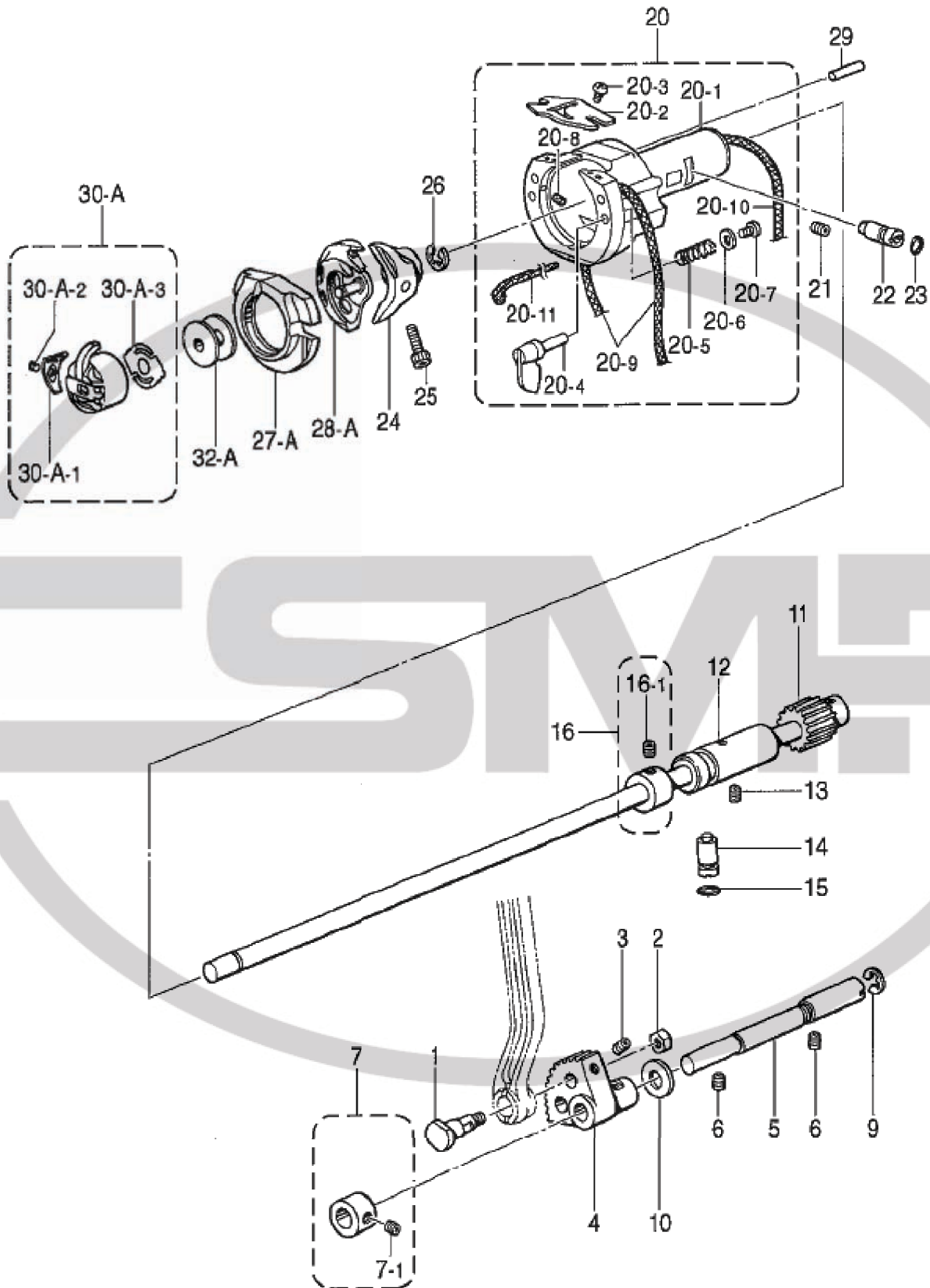

F1. 下軸関係 / Lower shaft mechanism

REF.NO	CODE	QTY	ヒンメイ	NAME OF PARTS	RM
1	141786001	1	クランクワツ・タンネジ	SHOULDER SCREW	
2	104689002	1	ナツ7.14	NUT, SM7.14	
3	014680622	1	アツメネジ 4.37ホミ	SET SCREW, SOCKET (CP) SM4.37	
4	S10145001	1	ヨツノギギヤ	ROCKER GEAR	
5	S11314101	1	ヨツノギギヤシク	ROCKER GEAR SHAFT	
6	014760622	2	アツメネジ 5.95	SET SCREW, SOCKET SM5.95	
7	S21774001	1	セツカークミ	SET SCREW COLLAR ASSY	
7-1	123006001	2	トメネジ 6.35ホミ	SET SCREW, (CP) SM6.35	
9	048080342	1	トメE8	RETAINING RING, E8	
10	110494001	1	ザカネ	WASHER, PLAIN 9.5	
11	S17896001	1	シタシクミ	LOWER SHAFT ASSY	
12	S10149101	1	シタシクメタル	BUSH, LOWER SHAFT	
13	014760622	1	アツメネジ 5.95	SET SCREW, SOCKET SM5.95	
14	152678201	1	カチヨセツシク	ADJUSTING STUD	
15	081003670	1	リング PW3	O-RING, PW3	
16	S03704002	1	セツカークミ	SET SCREW COLLAR ASSY	
16-1	014770632	2	アツホミ 635-40X6	SET SCREW, SOCKET(CP) SM6.35X6	
20	S55650201	1	オカマタイSP1クミ	SHUTTLE RACE BASE ASSY, SP1	
20-1	S52828101	1	オカマタイ	SHUTTLE RACE BASE	
20-2	S02429101	1	カイトアンナイ	SHUTTLE RACE THREAD GUIDE	
20-3	062660412	2	ハコ318-40X4	SCREW, PAN SM3.18-40X4	
20-4	152683101	2	オカマトリツクメ	S-RACE BASE SETTING CLAW	
20-5	152684101	2	オカマトリツクハネ	SPRING, COMPRESSION	
20-6	402887001	2	ザカネ 3.2	WASHER, 3.2	
20-7	062660712	2	ハコ318-40X7	SCREW, PAN SM3.18-40X7	
20-8	S09043000	2	フェルト	FELT	
20-9	S25373000	2	クミモ3X3	WICK 3X3 (L=500)	
20-10	S25373000	1	クミモ3X3	WICK 3X3 (L=500)	
20-11	S55651000	1	クミモ3X3	WICK, 3X3	
21	014760622	1	アツメネジ 5.95	SET SCREW, SOCKET SM5.95	
22	152678201	1	カチヨセツシク	ADJUSTING STUD	
23	081003670	1	リング PW3	O-RING, PW3	
24	152681201	1	ドライバ	DRIVER	
25	018501422	1	アツホミ 5X14	BOLT, SOCKET M5X14	
26	048080342	1	トメE8	RETAINING RING, E8	
27-1	152682101	1	オカマ	SHUTTLE RACE BASE, A	
28-1	SA2173001	1	S59161カマハコクミ (LF)	SHUTTLE HOOK ASSY, W/BOXS59161 (LF)	
27-2	152686101	1	オカマB	SHUTTLE RACE BASE, B	
28-2	SA1890001	1	S59162カマハコクミ (LG)	SHUTTLE HOOK ASSY, W/BOXS59162 (LG)	
29	S16290001	1	ニードル 4X19.8	NEEDLE ROLLER, 4X19.8	
30-1	S59221001	1	ホビンケースLC	BOBBIN CASE ASSY, LC	
30-1-1	S48664001	1	ケースチヨウシハネAN	TENSION SPRING, AN	
30-1-2	S16492101	1	ホビンケースハネネジ	BOBBIN CASE SPRING SCREW	
30-1-3	S15667001	1	クテンホウシハネ	ANTI-SPIN SPRING	
30-2	S59222001	1	ホビンケースLD	BOBBIN CASE ASSY, LD	
30-2-1	S16075101	1	ケースチヨウシハネB	TENSION SPRING, B	
30-2-2	S16492101	1	ホビンケースハネネジ	BOBBIN CASE SPRING SCREW	
30-2-3	S15667001	1	クテンホウシハネ	ANTI-SPIN SPRING	
32-1	S15665001	1	ホビンLA	BOBBIN, LA	
32-2	S15666001	1	ホビンLB	BOBBIN, LB	

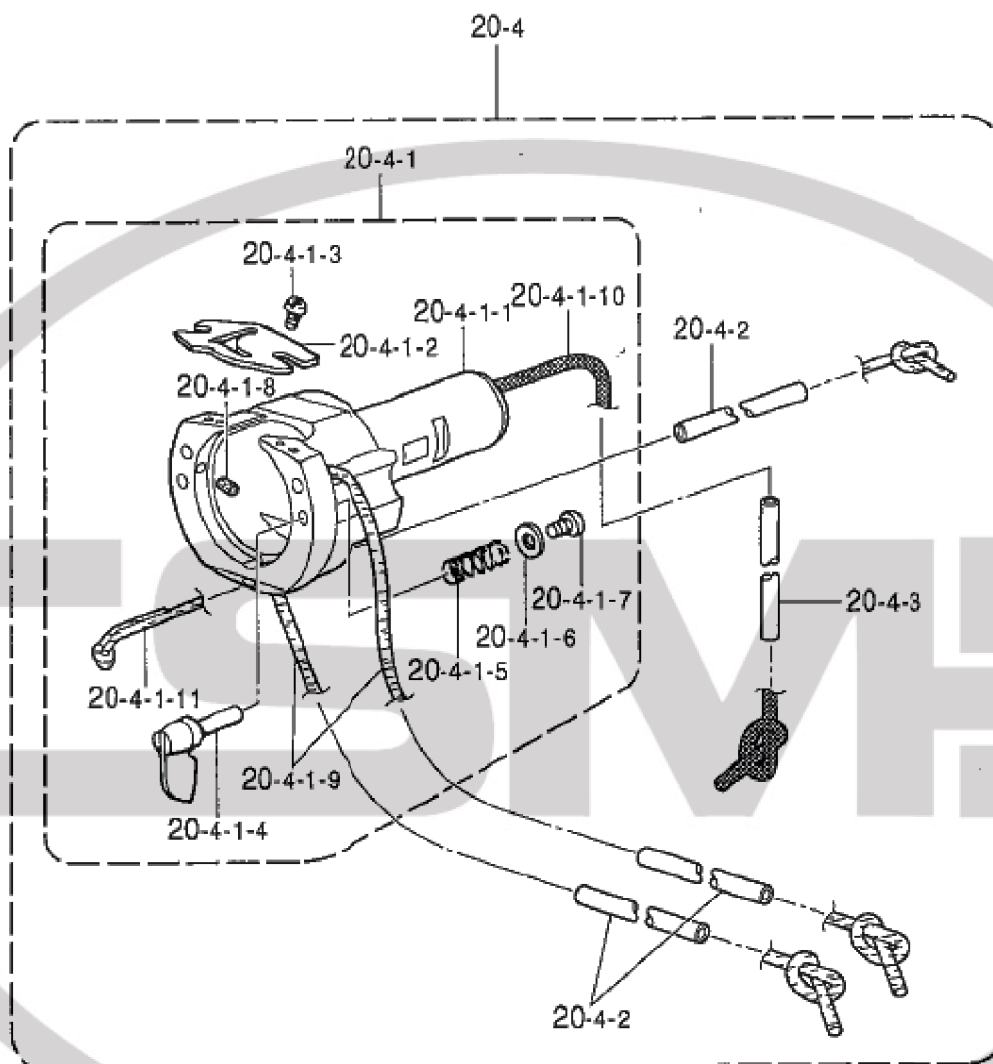

F2. 下軸関係 (オプション部品) / Lower shaft mechanism (Option parts)

REF.NO	CODE	QTY	ヒンメイ	NAME OF PARTS	RM
			<フェルト給油型>	<Felt lubrication type>	
20-4	S59895001	1	オカマイクミセット	SHUTTLE RACE BASE SET	
20-4-1	S59896001	1	オカマイクミ	SHUTTLE RACE BASE ASSY	
20-4-1-1	S52828101	1	オカマイ	SHUTTLE RACE BASE	
20-4-1-2	S02429101	1	カイトアンナイ	SHUTTLE RACE THREAD GUIDE	
20-4-1-3	062660412	2	ナ ^ハ コ318-40X4	SCREW, PAN SM3.18-40X4	
20-4-1-4	152683101	2	オカマトリツケツメ	S-RACE BASE SETTING CLAW	
20-4-1-5	152684101	2	オカマトリツケバネ	SPRING, COMPRESSION	
20-4-1-6	402887001	2	ワ ^サ ガ ^キ 3.2	WASHER, 3.2	
20-4-1-7	062660712	2	ナ ^ハ コ318-40X7	SCREW, PAN SM3.18-40X7	
20-4-1-8	S09043000	2	フェルト	FELT	
20-4-1-9	S59897001	2	フェルト	FELT	
20-4-1-10	S25373000	1	クミヒE3X3	WICK 3X3 (L=500)	
20-4-1-11	S59897001	1	フェルト	FELT	
20-4-2	S55652000	3	ヒ ^ツ コ ^リ ユ ^ー ブ ⁺	OIL TUBE, L=370	
20-4-3	S49623000	1	ヒ ^ツ コ ^リ ユ ^ー ブ ⁺	OIL TUBE, L=280	

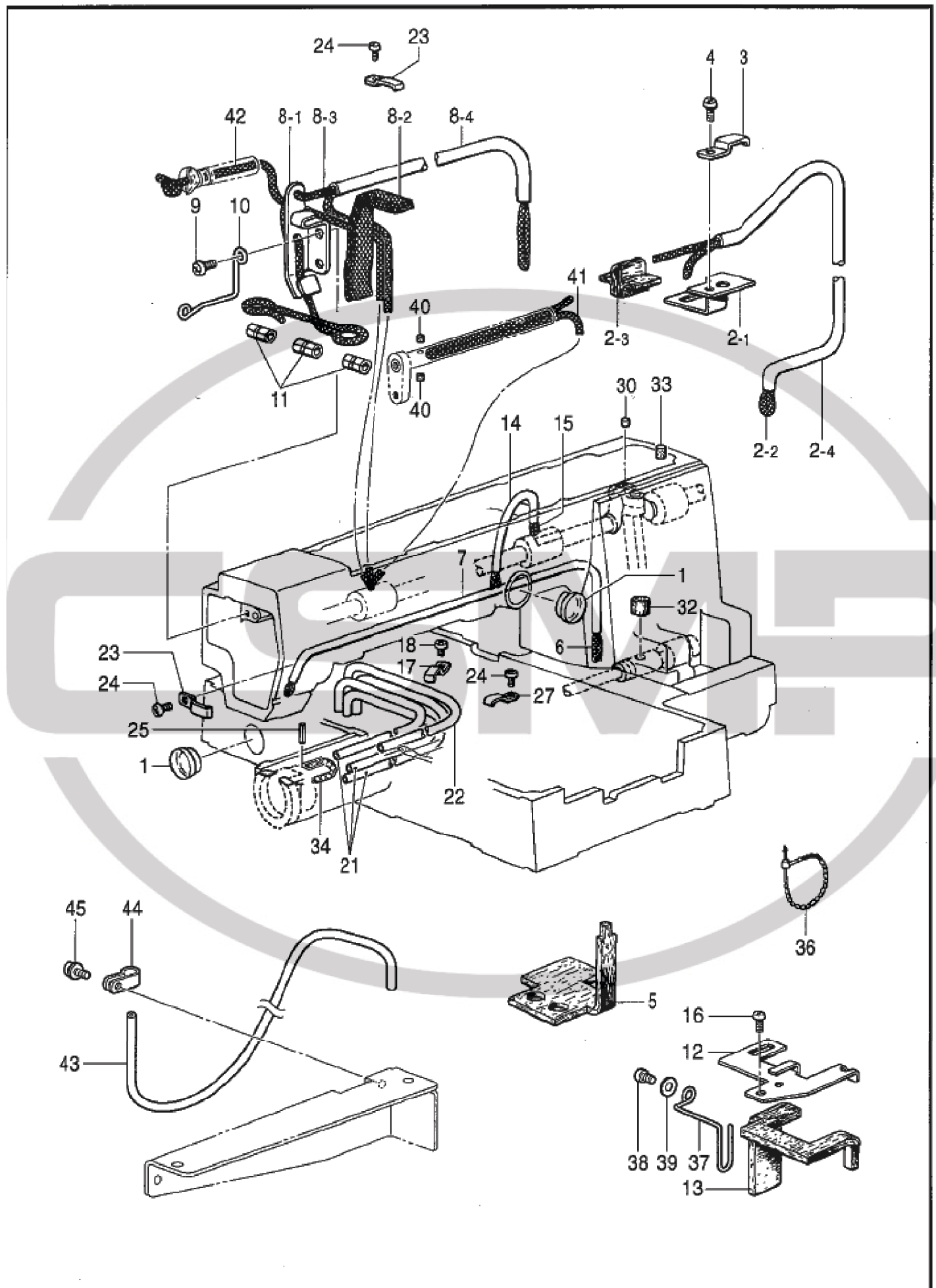

G. 給油潤滑関係 / Lubrication

REF.NO	CODE	QTY	品名	NAME OF PARTS	RM
1	152948001	2	オイルゲージ窓	OIL GAUGE WINDOW	
2-1	S10364001	1	ワック支持	WICK SUPPORT	
2-2	S17901000	1	ワック	WICK, 4X4 L=460	
2-3	S10478000	1	ワックフェルト	FELT	
2-4	S17902000	1	オイルチューブ	OIL TUBE, L=180	
3	142268001	1	コードホルダ	CORD HOLDER, L	
4	062670612	1	ネジ	SCREW, PAN SM3.57-40X6	
5	S10155000	1	ワック	FELT	
6	S10156000	1	ワック	WICK, 4X4 L=1000	
7	S17903000	1	オイルチューブ	OIL TUBE, L=530	
8-1	S21527001	1	ワック支持	WICK SUPPORT	
8-2	152955001	1	ワック	FLAT WICK, L=210	
8-3	S17905000	1	ワック	WICK, 4X4 L=370	
8-4	S17906000	1	オイルチューブ	OIL TUBE, L=320	
9	062680612	1	ネジ	SCREW, PAN SM4.37-40X6	
10	S10162201	1	ワック支持	WICK SUPPORT	
11	104567101	3	ワック支持	WICK SUPPORT	
12	S17907201	1	ワック支持	LOWER SHAFT WICK SUPPORT	
13	S17908000	1	ワック支持	LOWER SHAFT WICK FELT	
14	S17910000	1	オイルチューブ	OIL TUBE, L=130	
15	S17911000	1	ワック	WICK, 4X4 L=360	
16	062680812	2	ネジ	SCREW, PAN SM4.37-40X8	
17	117150001	1	コードホルダ	CORD HOLDER	
18	062670612	1	ネジ	SCREW, PAN SM3.57-40X6	
21	S55652000	3	オイルチューブ	OIL TUBE, L=370	
22	S49623000	1	オイルチューブ	OIL TUBE, L=280	
23	142268001	2	コードホルダ	CORD HOLDER, L	
24	062670612	3	ネジ	SCREW, PAN SM3.57-40X6	
25	047251640	1	ピン	PIN, SPRING ROLL AW2.5	
27	142268001	1	コードホルダ	CORD HOLDER, L	
30	107149001	2	フェルト	FELT	
32	113006001	1	フェルト	FELT	
33	151927001	1	クラッチフェルト	FELT, ;CLUTCH	
34	S17905000	1	ワック	WICK, 4X4 L=370	
36	340400001	1	ビードバンド	BEAD BAND	
37	S33252001	1	ワック支持	FELT SUPPORT	
38	062680612	1	ネジ	SCREW, PAN SM4.37-40X6	
39	148847001	1	ワッシャー	WASHER, PLAIN 4.76	
40	S09043000	2	フェルト	FELT	
41	108802001	1	ワック	WICK, 4X4 L=250	
42	108802001	1	ワック	WICK, 4X4 L=250	
43	SA0987000	1	ビニールチューブ	VINYL TUBE	
44	149547000	1	コードホルダ	CORD HOLDER, 4N	
45	0A5400806	1	ネジ	SCREW, PAN (S/P WASHER) M4X8	

< A=1: 中原物用 / For Medium materials >
 < A=2: 厚物用 / For Heavy materials >

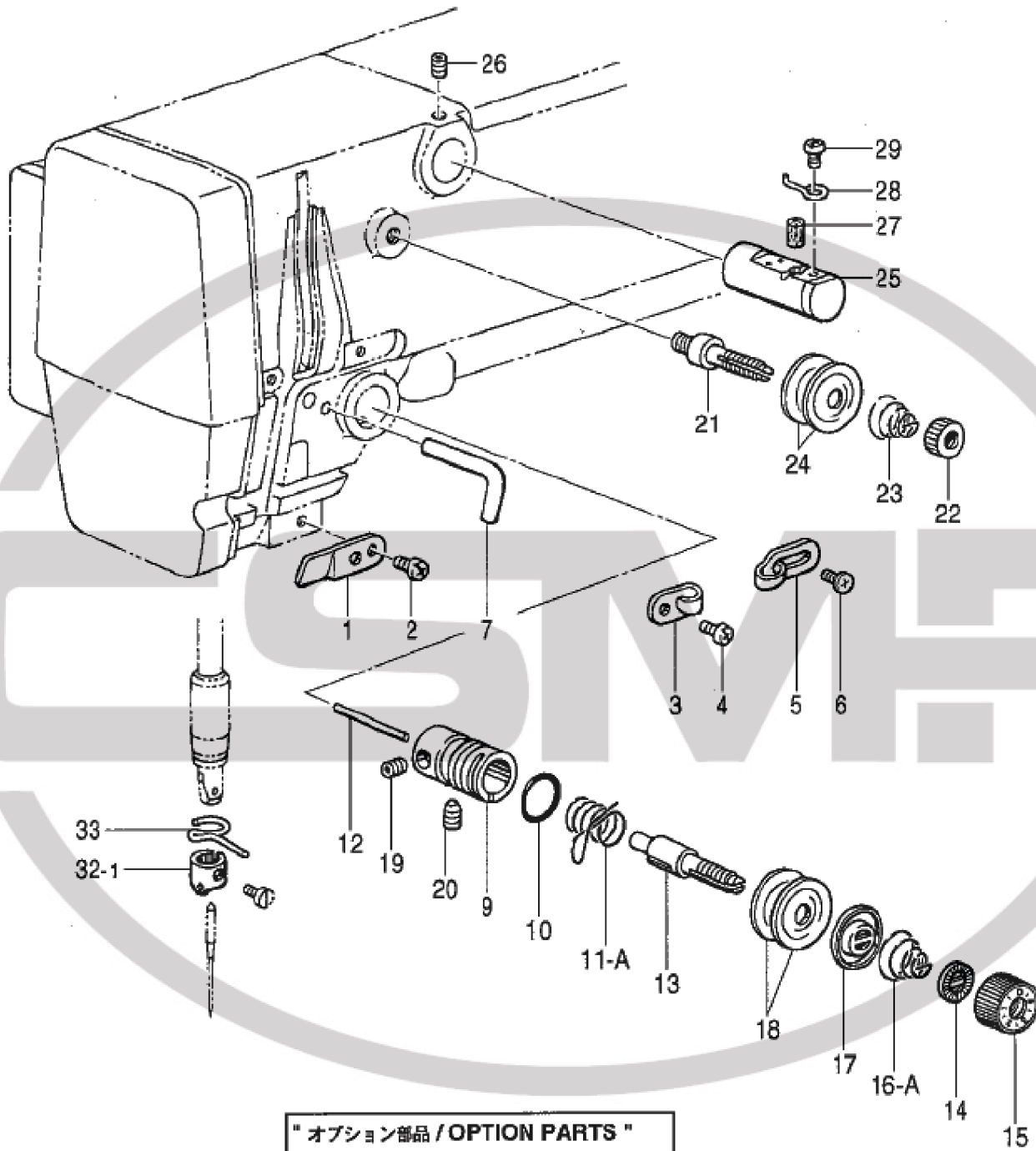

" オプション部品 / OPTION PARTS "



32-3



32-2

H. 糸通シ関係 / Threading mechanism

REF.NO	CODE	Q'TY	ヒンメイ	NAME OF PARTS	RM
1	152869001	1	アーム付子	ARM THREAD GUIDE	
2	062710612	1	サハコ3476-32X6	SCREW, PAN SM4.76-32X6	
3	152870001	1	アーム付子	ARM THREAD GUIDE	
4	062670612	1	サハコ357-40X6	SCREW, PAN SM3.57-40X6	
5	113316001	1	アーム付アンナイ	ARM THREAD GUIDE	
6	060670612	1	バインド357-40X6	SCREW, BIND SM3.57-40X6	
7	159224001	1	アーム付子	THREAD GUIDE, ARM	
9	152872001	1	付子取付台	TENSION BRACKET	
10	114294001	1	リング	O-RING	
			< 中厚物用 >	< For Medium materials >	
11-1	145519001	1	付子取付ネ	THREAD TAKE-UP SPRING	
			< 厚物用 >	< For Heavy materials >	
11-2	144588001	1	付子取付ネ	THREAD TAKE-UP SPRING, B	
12	150551000	1	付子取付ピン	TENSION RELEASE PIN	
13	116922001	1	付子取付スタッド	TENSION STUD	
14	S12441001	1	付子取付ワッシャー	WASHER	
15	S31032001	1	付子取付ナット	TENSION NUT	
			< 中厚物用 >	< For Medium materials >	
16-1	104525001	1	付子取付バネ	TENSION SPRING	
			< 厚物用 >	< For Heavy materials >	
16-2	107606001	1	付子取付バネ	TENSION SPRING, H	
17	159805001	1	付子取付圧入機	TENSION DISC PRESSER	
18	145446001	2	付子取付ディスク	TENSION DISC	
19	100402004	1	トメネジ 3.57	SET SCREW, SM3.57	
20	S10469001	1	ソケットネジ 5.95	SET SCREW, SOCKET SM5.95	
21	115186001	1	付子取付スタッド	MAIN TENSION STUD	
22	100136001	1	付子取付ナット	TENSION NUT	
23	115188001	1	付子取付バネ	TENSION SPRING	
24	145446001	2	付子取付ディスク	TENSION DISC	
25	152881001	1	針冷却機構	NEEDLE COOLER ASSY	
26	013760612	1	トメネジ 5.95x6.3	SET SCREW, (CP) SM5.95	
27	152883000	1	フェルト 8X15.5	FELT, 8X15.5	
28	152884001	1	針冷却機構用スリットガイド	NEEDLE COOLER THREAD GUIDE	
29	062670412	1	サハコ357-40X4	SCREW, PAN SM3.57-40X4	
32-1	S02438001	1	付子取付アンナイA	N-BAR THREAD GUIDE, A	
33	152891101	1	付子取付アンナイD	N-BAR BUSH THREAD GUIDE, D	
			" オプション部品 "	" OPTION PARTS "	
32-2	S02439001	1	付子取付アンナイB	N-BAR THREAD GUIDE, B	
32-3	S41222101	1	付子取付アンナイB	NEEDLE BAR THREAD GUIDE, B	
3-2	S51859101	1	アーム付アンナイ	ARM THREAD GUIDE	
4-2	060670612	1	バインド 357-40X6	SCREW, BIND SM3.57-40X6	
5-2	S49627001	1	アーム付子	ARM THREAD GUIDE	

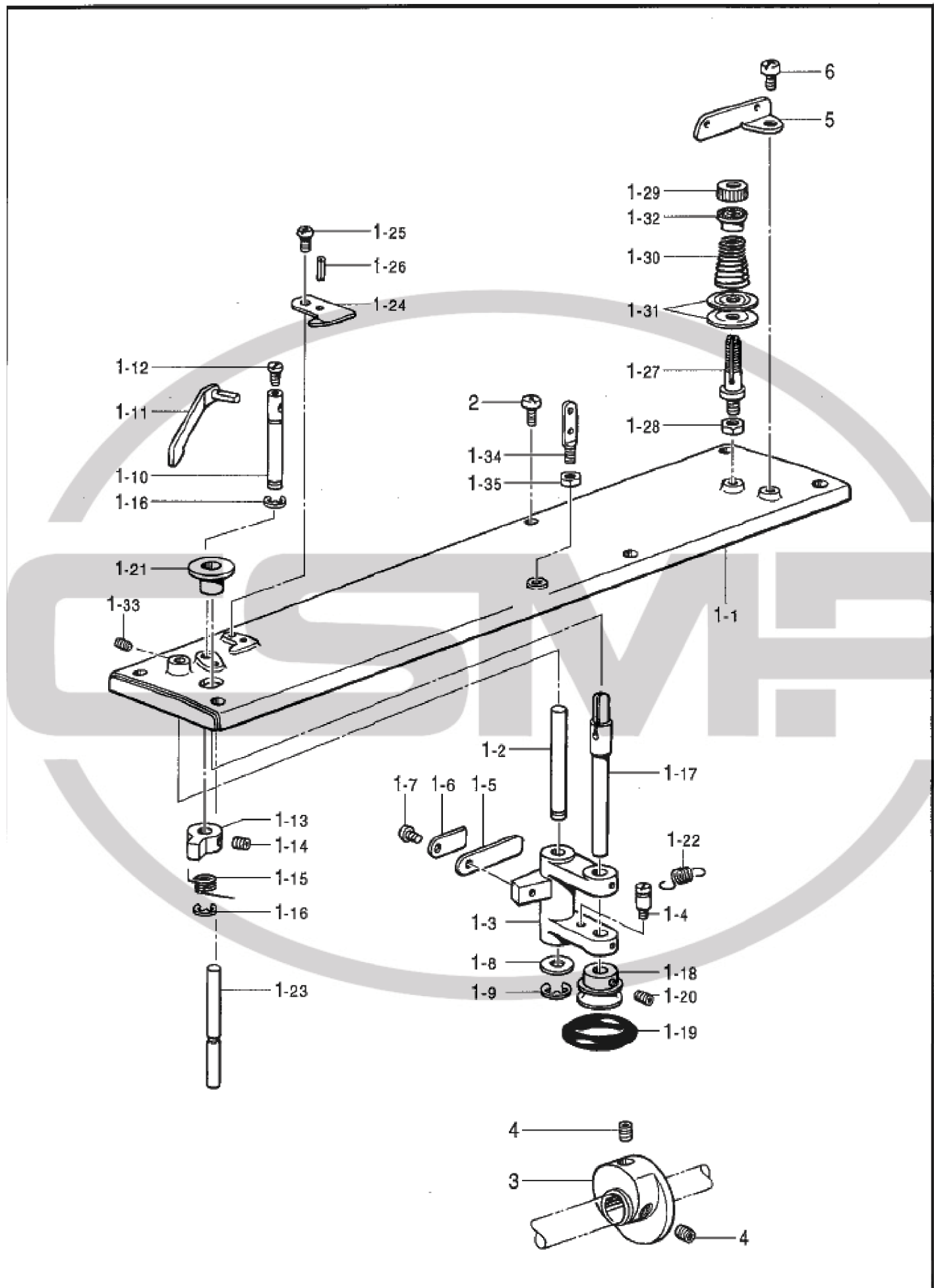

J. 糸巻関係 / Bobbin winder mechanism

REF.NO	CODE	QTY	ヒンメイ	NAME OF PARTS	RM
1-1	S17916001	1	ウツタ	TOP COVER	
1-2	S10172001	1	トマキレバ ^レ シ ^ク	BOBBIN WINDER LEVER SHAFT	
1-3	152984052	1	トマキレバ ^レ	BOBBIN WINDER LEVER	
1-4	141550001	1	テイルレバ ^レ ネ ^カ	SPRING HOOK	
1-5	152936001	1	イタ ^レ ネ	PLATE SPRING	
1-6	152937001	1	ワ ^カ ネ	WASHER	
1-7	062670612	1	ナ ^レ コ357-40X6	SCREW, PAN SM3.57-40X6	
1-8	159486001	1	ワ ^カ ネ	WASHER	
1-9	048050342	1	トメ ^レ E5	RETAINING RING, E5	
1-10	152940001	1	トマキ ^レ メ ^シ ク	BOBBIN WINDER CLAW STUD	
1-11	S10173001	1	ホ ^レ ン ^サ I	BOBBIN PRESSER	
1-12	S01998001	1	ア ^タ ツ ^ト メ ^シ 3.57	SET SCREW, SM3.57-40X6	
1-13	142566001	1	トマキ ^レ メ	CLAW FOR BOBBIN WINDER	
1-14	014680422	2	ア ^タ メ ^シ 4.37 ^ホ ミ	SET SCREW, SOCKET (CP) SM4.37	
1-15	S10438001	1	トマキ ^レ メ ^シ リ ^レ ネ	SPRING, TWIST	
1-16	048050342	2	トメ ^レ E5	RETAINING RING, E5	
1-17	152933001	1	トマキ ^レ シ ^ク	BOBBIN WINDER SHAFT	
1-18	154528001	1	トマキ ^レ ル ^マ	BOBBIN WINDER WHEEL	
1-19	120448001	1	ゴ ^ム ク	RUBBER BAND	
1-20	014680422	2	ア ^タ メ ^シ 4.37 ^ホ ミ	SET SCREW, SOCKET (CP) SM4.37	
1-21	S10174000	1	ホ ^リ ヨ ^ク イ ^タ	DUST GUARD PLATE	
1-22	S10268001	1	トマキ ^レ テ ^レ ネ	SPRING	
1-23	S10175001	1	スト ^レ バ ^レ シ ^ク	STOPPER SHAFT	
1-24	157968001	1	ヌ	KNIFE	
1-25	062680712	1	ナ ^レ コ437-40X7	SCREW, PAN SM4.73-40X7	
1-26	047201042	1	ス ^リ ン ^ク ヒ ^ン AW2	PIN, SPRING ROLL AW2X10	
1-27	159574101	1	ト ^チ ヨ ^ク シ ^ホ ウ	TENSION STUD	
1-28	021680202	1	ナ ^ツ 2 ^シ 4.37	NUT, 2 SM4.37	
1-29	100136001	1	ト ^チ ヨ ^ク シ ^ナ ツ	TENSION NUT	
1-30	144110001	1	シ ^ル レ ^バ イ ^ト チ ^ヨ ク ^シ ハ ^レ ネ	TENSION ADJUSTING SPRING	
1-31	145446001	2	ト ^チ ヨ ^ク シ ^ナ ツ	TENSION DISC	
1-32	144105000	1	チ ^ヨ ク ^シ ハ ^レ ネ ^ワ シ ^カ ネ	TENSION SPRING FLANGE WASHER	
1-33	148294001	1	ア ^タ メ ^シ 3.57 ^ホ ミ	SET SCREW, SOCKET (CP) SM3.57	
1-34	141590001	1	イ ^ト オ ^シ ホ ^ウ	THREADING BAR, U	
1-35	150553003	1	ナ ^ツ 5.95	NUT, SM5.95	
2	062711212	6	ナ ^レ コ476-32X12	SCREW, PAN SM4.76-32X12	
3	S47174000	1	トマキ ^レ ワ ^レ	BOBBIN WINDER PULLEY	
4	014760622	2	ア ^タ メ ^シ 5.95	SET SCREW, SOCKET SM5.95	
5	115183101	1	ト ^カ	THREAD RETAINER	
6	062711012	1	ナ ^レ コ476-32X10	SCREW, PAN SM4.76-32X10	

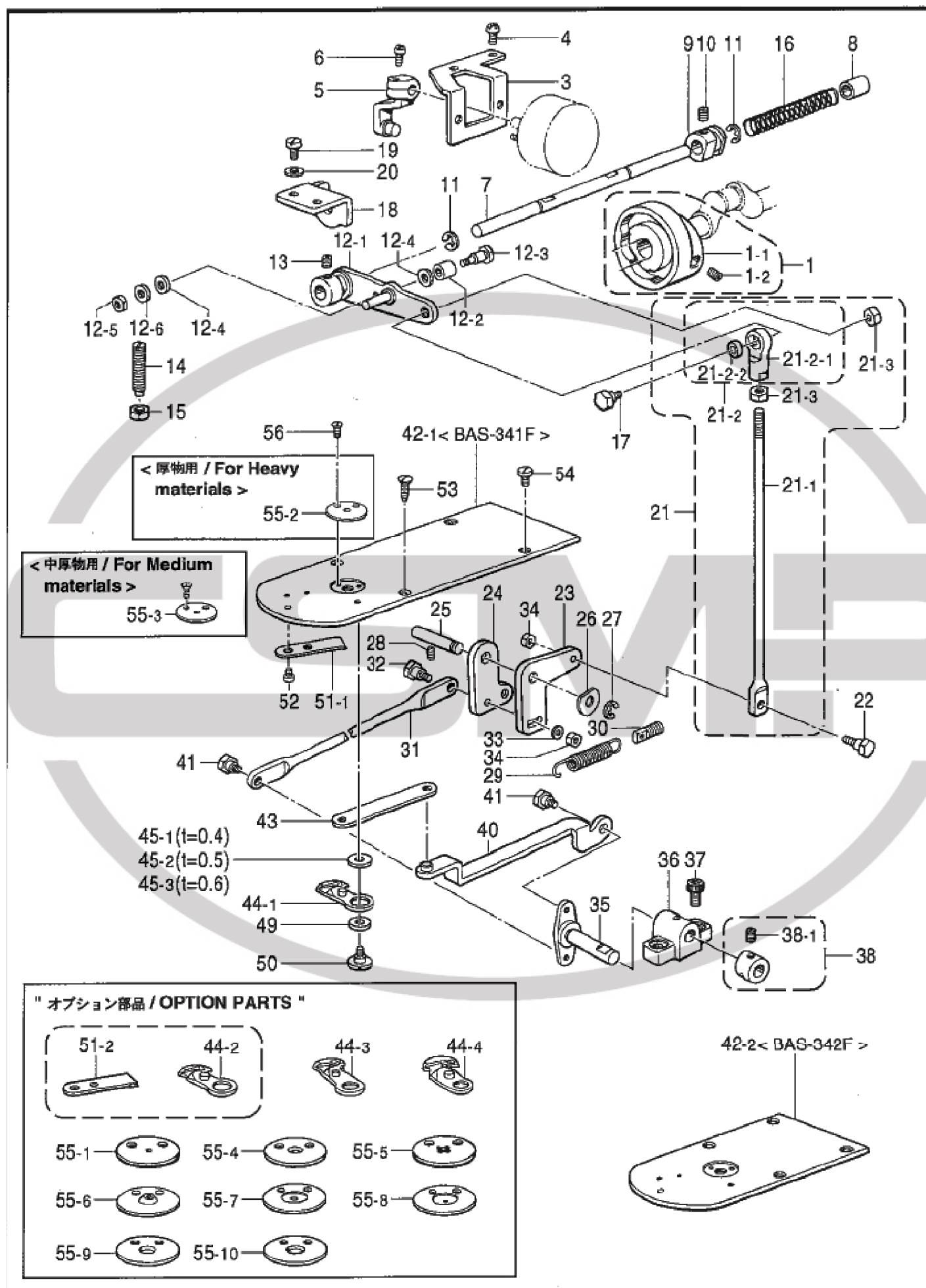

K. 糸切り関係 / Thread trimmer mechanism

REF.NO	CODE	QTY	ヒンメイ	NAME OF PARTS	RM
1	S37066001	1	糸切りカム	THREAD TRIMMER CAM ASSY	
1-1	S18653001	1	糸切りカム	THREAD TRIMMER CAM	
1-2	014770622	2	アットメジ 6.35クホミ	SET SCREW, SOCKET (CP) SM6.35	
3	S10178001	1	ソレノイドトリツケイタ	SOLENOID SETTING PLATE	
4	062681012	2	ハコ3437-40X10	SCREW, PAN SM4.37-40X10	
5	S10179001	1	ソレノイドレバークミ	SOLENOID LEVER ASSY	
6	062671012	1	ハコ3357-40X10	SCREW, PAN SM3.57-40X10	
7	S17918201	1	外ウレバアンナイシク	DRIVING LEVER GUIDE SHAFT	
8	231071001	1	メタル8X15	BUSH, 8X15	
9	S18919001	1	外ウレバクカラ	DRIVING LEVER COLLAR	
10	014760622	2	アットメジ 5.95	SET SCREW, SOCKET SM5.95	
11	048070342	2	トメ7E7	RETAINING RING, E7	
12-1	S30117101	1	糸切りカムレバークミ	TH-TRIMMER DRIVING LEVER ASSY	
12-2	153597001	1	シタイトレバークカラ	LOWER THREAD RETAINER COLLAR	
12-3	S30033001	1	ダンネジ 3.57	SHOULDER SCREW, SM3.57	
12-4	148813001	2	ワッシャー	WASHER	
12-5	106129002	1	ナット 3.57	NUT, SM3.57	
12-6	028350242	1	ワッシャー スプリング 2-3.5	WASHER, SPRING 2-3.5	
13	014770622	1	アットメジ 6.35クホミ	SET SCREW, SOCKET (CP) SM6.35	
14	159905001	1	トメヌイヨウセツネジ	ADJUSTING SCREW	
15	106147002	1	ナット 7.94	NUT, SM7.94	
16	S10189001	1	外ウレバコトシハネ	SPRING, COMPRESSION	
17	S02354001	1	タマツキテタンネジ B	SHOULDER SCREW, B	
18	S17922001	1	外ウレバストップ	DRIVING LEVER STOPPER	
19	107093002	2	シメネジ 4.37	SCREW, SM4.37	
20	025680232	2	ワッシャー 平 M 4.37	WASHER, PLAIN M 4.37	
21	S10267001	1	糸切りロッドカム	THREAD TRIMMER ROD ASSY, S	
21-1	S10191001	1	糸切りロッド S	THREAD TRIMMER ROD, S	
21-2	141492001	1	タマツキテカム	JOINT ASSY	
21-2-1	141493001	1	タマツキテタイ	JOINT	
21-2-2	141331001	1	キョウメツアシ	BUSH	
21-3	106588003	2	ナット 5.95	NUT, SM5.95	
22	S10192001	1	ダンネジ 4.37	SHOULDER SCREW, SM4.37	
23	S10193001	1	糸切りレバ D	THREAD TRIMMER LEVER, D	
24	S10194001	1	糸切りレバ U	THREAD TRIMMER LEVER, U	
25	S10195001	1	糸切りレバシク	THREAD TRIMMER LEVER SHAFT	
26	110367001	1	ワッシャー	WASHER, PLAIN SPECIAL 8	
27	048060342	1	トメ7E6	RETAINING RING, E6	
28	014760622	1	アットメジ 5.95	SET SCREW, SOCKET SM5.95	
29	S10196101	1	糸切りレバヒキハネ	SPRING, EXTENTION	
30	110146001	1	フヨウセツキハネカガシ	SPRING HOOK, S	
31	S17923001	1	糸切りロッド L	THREAD TRIMMER ROD, L	
32	S10192001	1	ダンネジ 4.37	SHOULDER SCREW, SM4.37	
33	025680232	1	ワッシャー 平 M 4.37	WASHER, PLAIN M 4.37	
34	021680202	2	ナット 2.5 SM4.37	NUT, 2 SM4.37	
35	S17924101	1	レバシキ	CONNECTING LEVER	
36	S17925000	1	レバシキササエ	CONNECTING LEVER SUPPORT	
37	018501222	2	アットメジ M5X12	BOLT, SOCKET M5X12	
38	183827001	1	セットカム	SET SCREW COLLAR ASSY	
38-1	014770622	2	アットメジ 6.35クホミ	SET SCREW, SOCKET (CP) SM6.35	
40	S49059101	1	糸切りレバカム	TH-TRIMMER CONNECTING ROD ASSY	
41	S18055001	2	ダンネジ 4.37	SHOULDER SCREW, SM4.37	
42-1	S17929001	1	針板 <BAS-341F用>	NEEDLE PLATE <For BAS-341F>	
42-2	S30957001	1	針板 <BAS-342F用>	NEEDLE PLATE <For BAS-342F>	

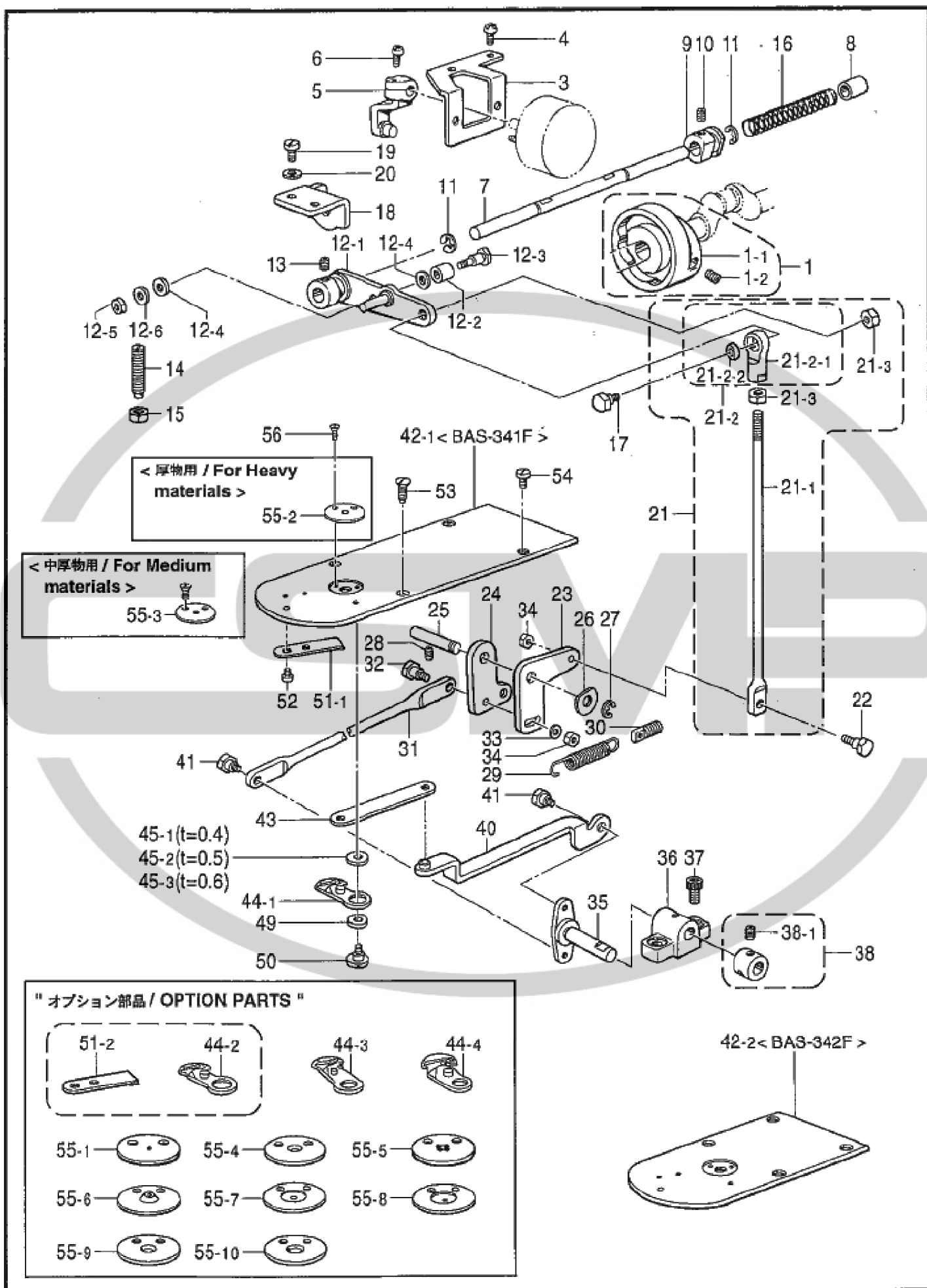

K. 糸切り関係 / Thread trimmer mechanism

REF.NO	CODE	QTY	ヒンメイ	NAME OF PARTS	RM
43	S10204101	1	トキリシカ	THREAD TRIMMER CONNECTING ROD	
44-1	S10205001	1	トウカミ	MOVABLE KNIFE ASSY	
45-1	S10208001	1	トウカシ (t=0.4)	MOVABLE KNIFE SPACER (t=0.4)	
45-2	S10208002	1	トウカシ (t=0.5)	MOVABLE KNIFE SPACER (t=0.5)	
45-3	S10208003	1	トウカシ (t=0.6)	MOVABLE KNIFE SPACER (t=0.6)	
49	S00705001	1	トウカテ	MOVABLE KNIFE COLLAR	
50	S10209101	1	シメジ 4.37	SCREW, SM4.37	
51-1	S10210201	1	コテハ	FIXED KNIFE	
52	111140002	2	シメジ 2.38	SCREW, SM2.38	
53	158384001	2	フラジ 4.37	SCREW, FLAT SM4.37	
54	S11244001	2	シメジ 4.37	SCREW, SM4.37	
			<厚物用>	<For Heavy materials>	
55-2	S10212101	1	リアナイフ	NEEDLE HOLE PLATE, E	
			<中厚物用>	<For Medium materials>	
55-3	S10213001	1	リアナイフ	NEEDLE HOLE PLATE, F	
56	100360003	2	フラジ 2.38	SCREW, FLAT SM2.38	
			"オプション部品"	"OPTION PARTS"	
44-2	S31612001	1	トウカヨコウミ	MOVABLE KNIFE ASSY, H/MATERIAL	
44-3	S40934101	1	トウカミ	MOVABLE KNIFE ASSY, L	
44-4	S40846001	1	トウカWPミ	MOVABLE KNIFE ASSY, WP	
51-2	S30128001	1	コテハヨコウ	FIXED KNIFE, HARD MATERIAL	
55-1	S10211001	1	リアナイフA	NEEDLE HOLE PLATE, A	
55-4	S25127001	1	リアナイフL	NEEDLE HOLE PLATE, L	
55-5	S29997001	1	リアナイフD	NEEDLE HOLE PLATE, D	
55-6	S30450001	1	リアナイフH	NEEDLE HOLE PLATE, H	
55-7	S30925001	1	リアナイフED	NEEDLE HOLE PLATE, ED	
55-8	S30926001	1	リアナイフFD	NEEDLE HOLE PLATE, FD	
55-9	S40217001	1	リアナイフ3サクリ	NEEDLE HOLE PLATE, 3	
55-10	S34348001	1	リアナイフM	NEEDLE HOLE PLATE, M	

L. 糸払イ関係 / Thread wiper mechanism

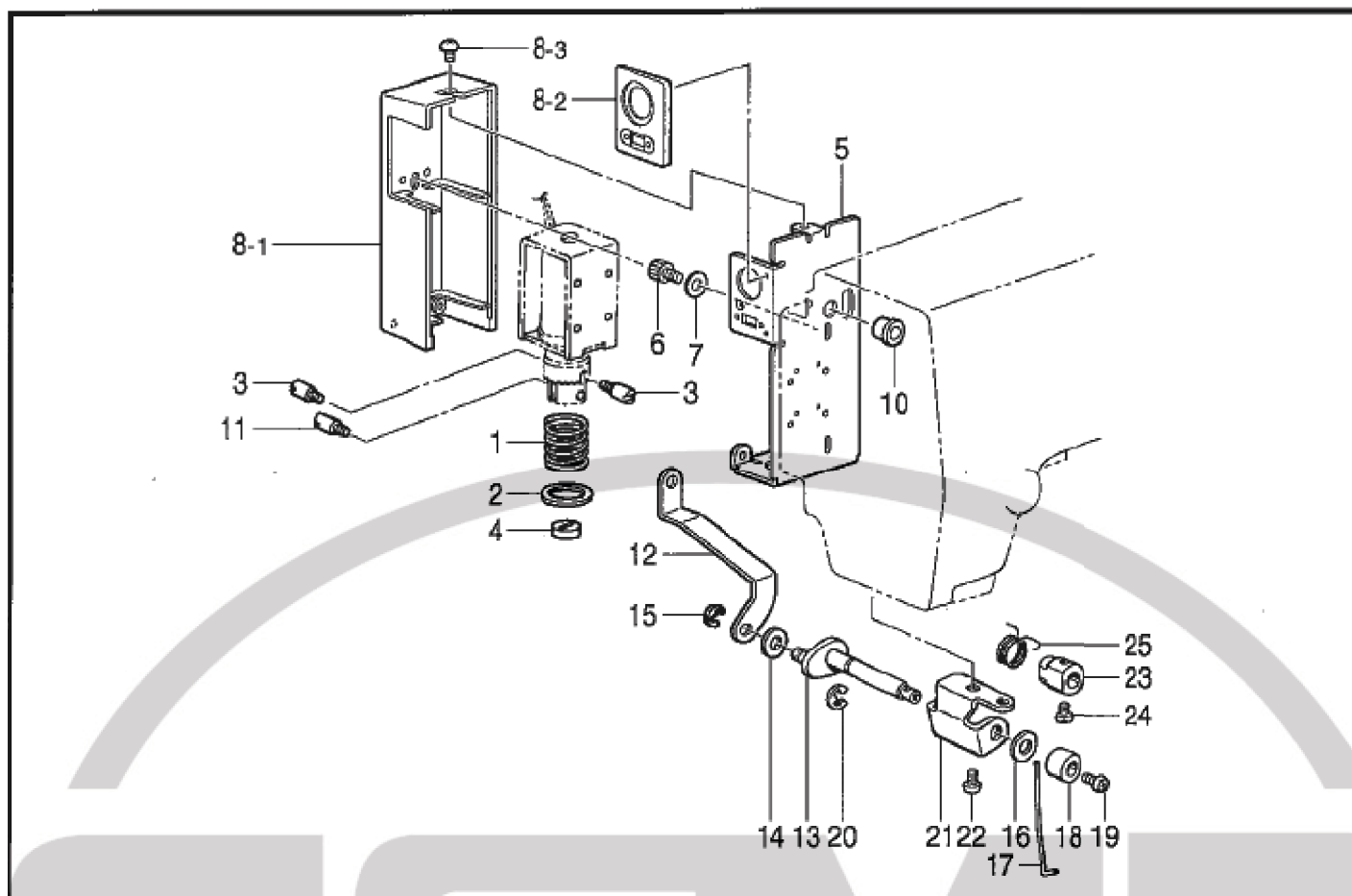

151-V41-405

M. プログラマー関係 (オプション部品) / Programmer (Option parts)

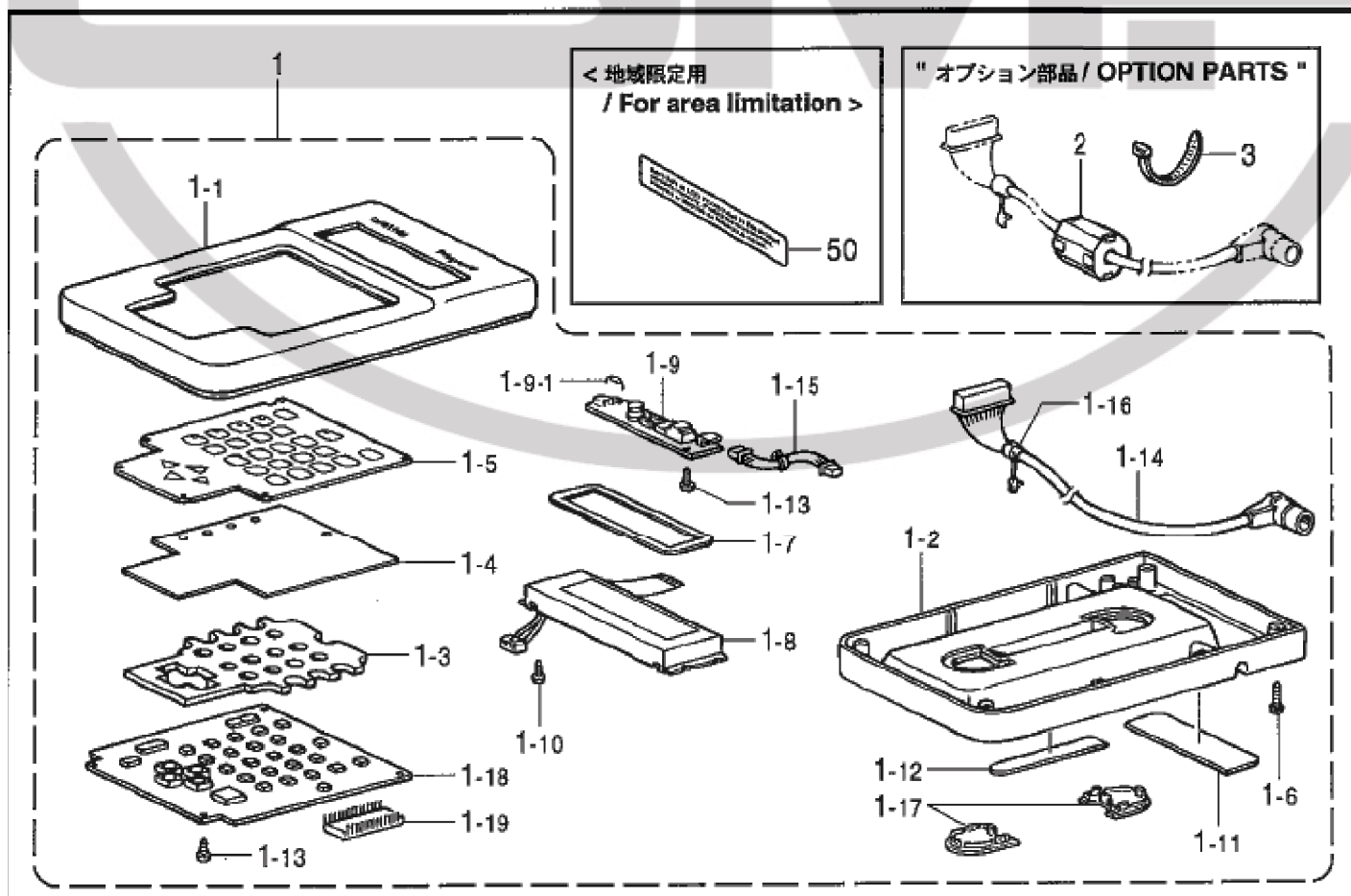

151-V41-942

L. 糸払イ関係 / Thread wiper mechanism

REF.NO	CODE	Q'TY	ヒンメイ	NAME OF PARTS	RM
1	S41206001	1	イトハラハネ	THREAD WIPER SPRING	
2	S41205001	1	ヒラサガネ	WASHER, PLAIN	
3	S25456001	2	プランジヤピン	PLUNGER PIN	
4	S41207000	1	スハコゴム	SPACER RUBBER	
5	S55149100	1	イトハラ(SOL)リツクイタ	WIPER SOL. SETTING PLATE	
6	018681022	2	アホルト4.37X10	BOLT, SOCKET SM4.37X10	
7	100645003	2	サカネ	WASHER	
8-1	S55150000	1	イトハラ(SOL)カバー	SOL. COVER	
8-2	S55133000	1	イトハラ(SOL)カバーフタ	LID, S-COVER	
8-3	008400604	3	トラスJ4X6	SCREW, TRUSS M4X6	
10	S38059000	1	ゴムメットNG79F	RUBBER CAP, NG79F	
11	S25456001	1	プランジヤピン	PLUNGER PIN	
12	S42858001	1	イトハラレンカン	THREAD WIPER CONNECTING ROD	
13	S10217101	1	イトハラクランクミ	THREAD WIPER CRANK ASSY	
14	110735001	1	サカネ	WASHER	
15	048030342	1	トメ7E3	RETAINING RING, E3	
16	025750132	1	ヒラサガネ5.56	WASHER, PLAIN S 5.56	
17	S10470101	1	ワイハ	WIPER	
18	146288001	1	イトハラジグカラー	THREAD WIPER STUD COLLAR	
19	060680512	1	バインド437-40X5	SCREW, BIND SM4.37-40X5	
20	048040342	1	トメ7E4	RETAINING RING, E4	
21	S02672002	1	イトハラジグクケイタ	THREAD WIPER SUPPORT	
22	062680512	2	パネコ437-40X5	SCREW, PAN SM4.37-40X5	
23	S02677001	1	セットカラー	SET SCREW COLLAR	
24	144458001	1	アタマツトメネジ3.57	SET SCREW, SM3.57-40X4.5	
25	S02678001	1	ワイハハネ	WIPER SPRING	

151-V41-405

M. プログラマー関係 (オプション部品) / Programmer (Option parts)

REF.NO	CODE	Q'TY	ヒンメイ	NAME OF PARTS	RM
1	S43249101	1	プログラマクミ	PROGRAMMER ASSY	
1-1	S43250100	1	プログラマウイフタ	PROGRAMMER TOP COVER	
1-2	S43251000	1	プログラマシタフタ	PROGRAMMER LOWER COVER	
1-3	S43252000	1	キーボードスハコ	KEYBOARD SPACER	
1-4	S43253000	1	キーボードゴムシート	KEYBOARD RUBBER SHEET	
1-5	S43254100	1	キーボードシート	KEYBOARD SHEET	
1-6	037301015	4	パネツツピン3X10	TAPPING SCREW, PAN V M3X10	
1-7	S43255000	1	LCDカバー	LCD COVER	
1-8	S43256000	1	LCD	LCD	
1-9	S59652000	1	LCDインバーターF1A	INVERTER, LCD :F1A	
1-9-1	S59660000	1	マイクロフズ1A	MICRO FUSE, 1A	
1-10	037200615	4	パネツツピン2X6	TAPPING SCREW, PAN V M2X6	
1-11	S43271000	1	プログラママグネットA	MAGNET, A	
1-12	S43272000	1	プログラママグネットB	MAGNET, B	
1-13	037300615	6	パネツツピン3X6	TAPPING SCREW, PAN V M3X6	
1-14	S43267000	1	プログラマコード	PROGRAMMER HARNESS	
1-15	S43268000	1	インバーターハネ	INVERTER HARNESS	
1-16	S43270000	1	コードブッシュKR51	CORD BUSH, KR51	
1-17	S43981000	2	プログラマシタカバー	PROGRAMMER UNDER COVER	
1-18	S43259101	1	プログラマPCBクミ	PROGRAMMER PCB ASSY	
1-19	S43269000	1	PROMプログラマクミ	PROM PROGRAMMER ASSY	
			"オプション部品"	"OPTION PARTS"	
2	S40621000	1	EMIコアESD-SR-15	EMI CORE, ESD-SR-15	
3	149809000	1	タイラップL	BEAD BAND, L=200	
			<地域限定用>	<For area limitation>	
50	S52582001	1	水銀警告ラベルP2	MERCURY WARNING LABEL 14X70 P2	

151-V41-942

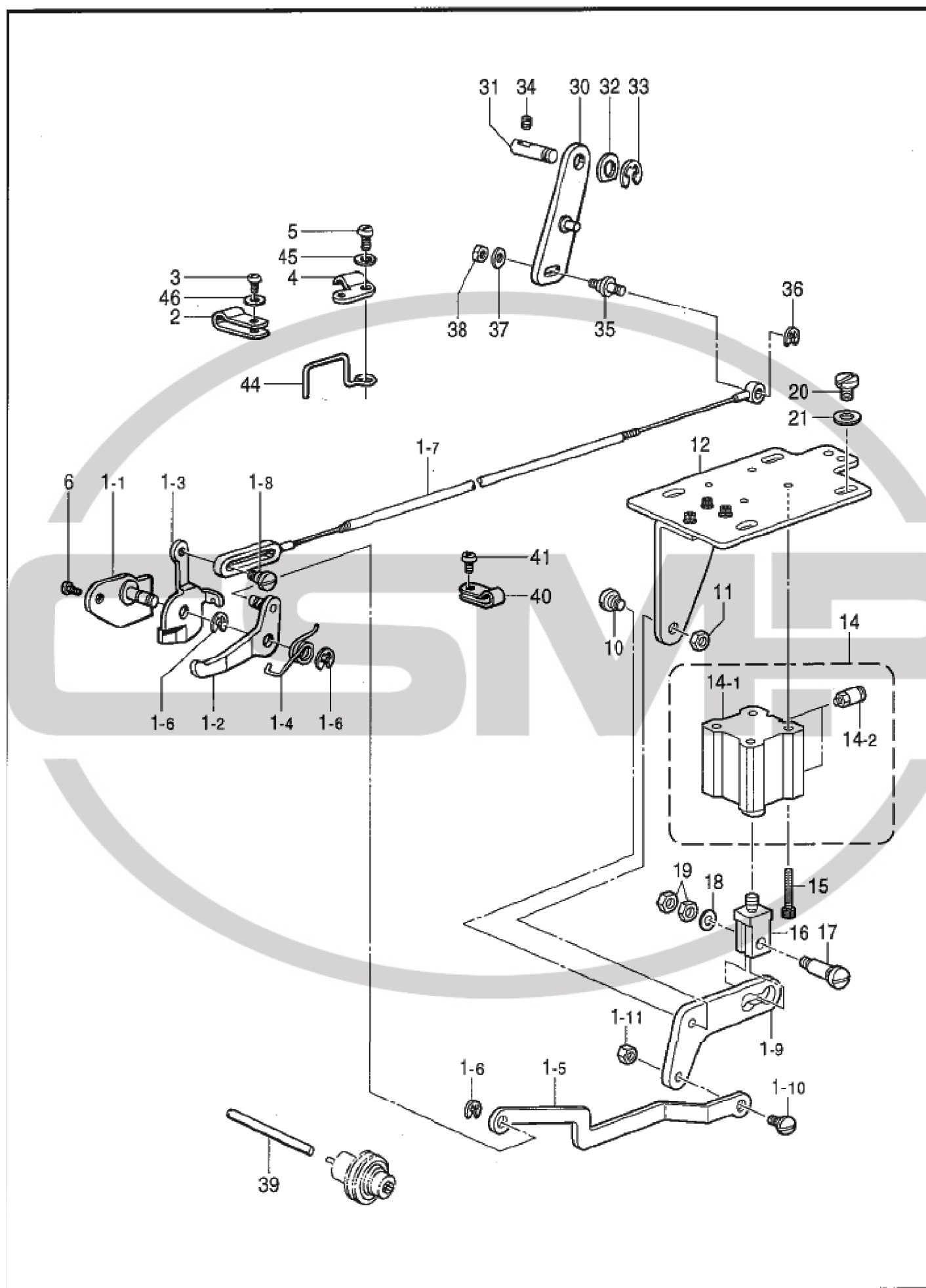

N. 糸締メ関係 / Thread nipper mechanism

REF.NO	CODE	QTY	ヒンメイ	NAME OF PARTS	RM
1	S47151001	1	イトユルメクミ	TENSION RELEASE ASSY	
1-1	S17933001	1	イトユルメフ ^ラ ケツト	TENSION RELEASE BRACKET	
1-2	S17934001	1	オサエアケ ^レ ハ ^ク ミ	WORK CLAMP LIFTER LEVER ASSY	
1-3	S10228001	1	イトコル ^レ ハ ^ク	TENSION RELEASE LEVER	
1-4	S10229101	1	オサエ ^レ ハ ^ク ネ	SPRING	
1-5	S47143001	1	レハ ^ク タイレンカン	CONNECTING ROD, W-CLAMP LIFTER	
1-6	048040342	3	トメ ^レ E4	RETAINING RING, E4	
1-7	S17937001	1	オサエアケ ^レ ワイヤクミ	PRESSER BAR WIRE ASSY	
1-8	147476001	1	タ ^ン ネジ ^シ 4.37	SHOULDER SCREW, SM4.37	
1-9	S47142001	1	レハ ^ク タイク ^ト ウレハ ^ク	DRIVING LEVER, W-CLAMP LIFTER	
1-10	107321003	1	タ ^ン ネジ ^シ 4.76	SHOULDER SCREW, SM4.76	
1-11	021710102	1	ナツト1 ^ツ ユ4.76	NUT, 1 SM4.76	
2	S10243000	1	ナイロンランフ ^ク NK-3N	CORD HOLDER, NK-3N	
3	062670612	1	ナ ^ハ コ357-40X6	SCREW, PAN SM3.57-40X6	
4	153941001	1	ワイヤオサエ	WIRE HOLDER	
5	062681012	1	ナ ^ハ コ437-40X10	SCREW, PAN SM4.37-40X10	
6	062771012	1	ナ ^ハ コ635-40X10	SCREW, PAN SM6.35-40X10	
10	S48662001	1	タ ^ン ネジ ^シ 5.95	SHOULDER SCREW, SM5.95	
11	100022005	1	ナツト5.95	NUT, SM5.95	
12	S47144101	1	シリンダ ^ク トリツケイタ ^ク ミ	CYLINDER SETTING PLATE ASSY	
14	S46144100	1	シリンダ ^ク 25X15 ^ク ミ	CYLINDER ASSY, 25X15	
14-1	S46145000	1	シリンダ ^ク 25X15	CYLINDER, 25X15	
14-2	S04905000	2	ハ ^ク フエオン	HALF UNION	
15	018503536	4	アサホ ^ク ルト5X35	BOLT, SOCKET M5X35	
16	S43903001	1	シリンダ ^ク ツキ ^テ	CYLINDER JOINT	
17	148764001	1	タ ^ン ネジ ^シ 4.76	SHOULDER SCREW, SM4.76	
18	118735001	1	サ ^ク ガ ^ク ネ	WASHER	
19	110161004	2	ナツト4.76	NUT, SM4.76	
20	S03403001	4	ストップ ^ク ハ ^ク ネジ ^シ	STOPPER SCREW	
21	S03695001	4	サ ^ク ガ ^ク ネ6	WASHER, PLAIN 6	
30	S17945101	1	オサエ ^レ アケ ^レ ハ ^ク クミ	PRESSER ROD LEVER ASSY	
31	159264001	1	シタイ ^ク シリ ^レ ハ ^ク ネ ^ク ピン	PIN	
32	110367001	1	サ ^ク ガ ^ク ネ	WASHER, PLAIN SPECIAL 8	
33	048060342	1	トメ ^レ E6	RETAINING RING, E6	
34	014760622	1	アサトメ ^ク ネジ ^シ 5.95	SET SCREW, SOCKET SM5.95	
35	S17949001	1	イトユル ^レ ワイヤ ^ク シ ^ク	WIRE SHAFT, TENSION RELEASE	
36	048040342	1	トメ ^レ E4	RETAINING RING, E4	
37	100645003	1	サ ^ク ガ ^ク ネ	WASHER	
38	021680212	1	ナツト2 ^ツ ユ4.37	NUT, 2 SM4.37	
39	S10239001	1	イトユル ^レ ホ ^ク ウ	TENSION RELEASE STUD	
40	149547000	1	コ ^ト オサエ	CORD HOLDER, 4N	
41	062680812	1	ナ ^ハ コ437-40X8	SCREW, PAN SM4.37-40X8	
44	S10232001	1	ケ ^フ サ ^ク サ ^ク エ	CABLE SUPPORT	
45	148847001	1	サ ^ク ガ ^ク ネ	WASHER, PLAIN 4.76	
46	025350332	1	ヒラサ ^ク ガ ^ク ネ ^ク 13.5	WASHER, PLAIN L 3.5	

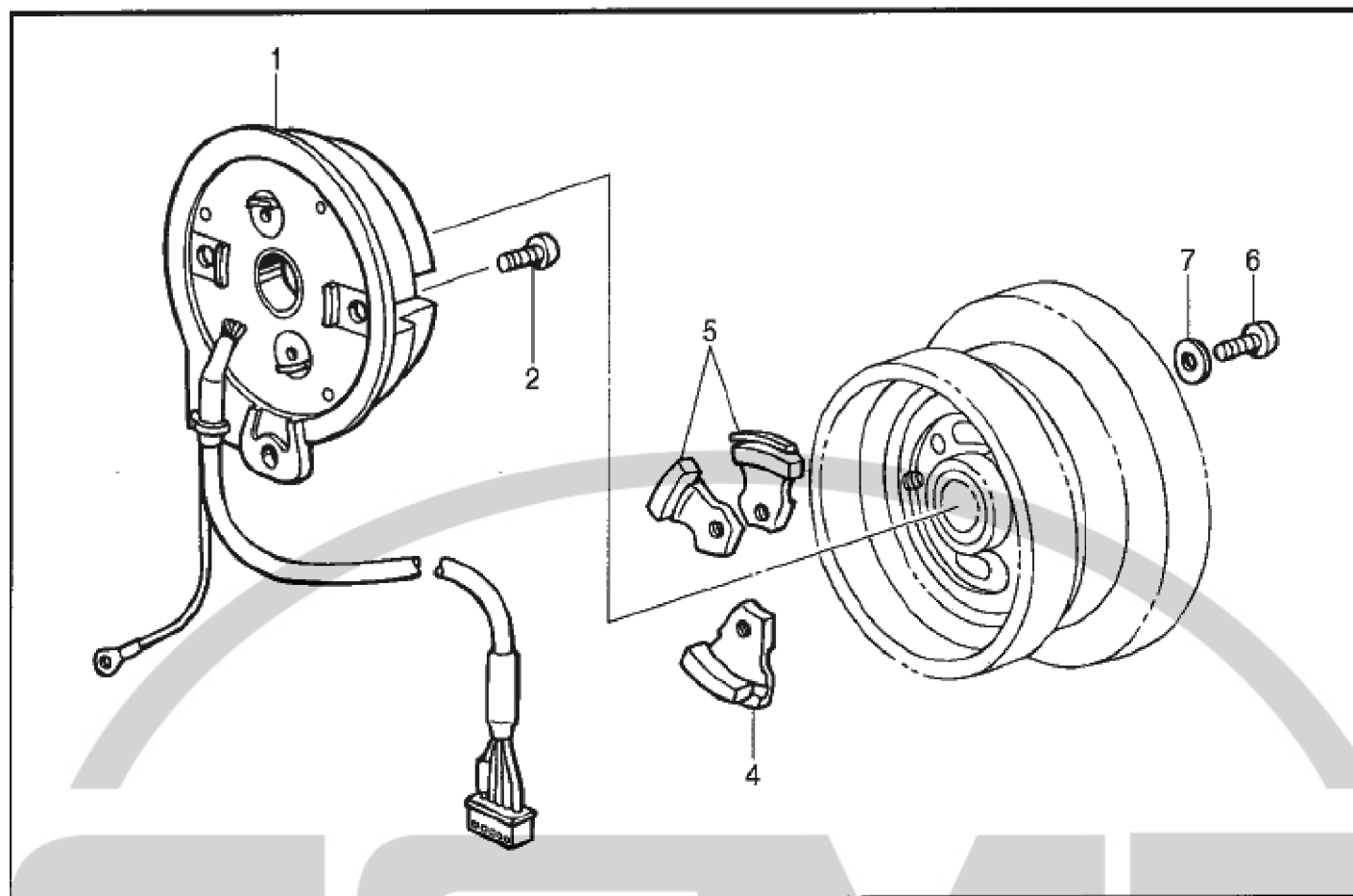

151-V41-501

Q . プリント基板関係 / Printed circuit board mechanism

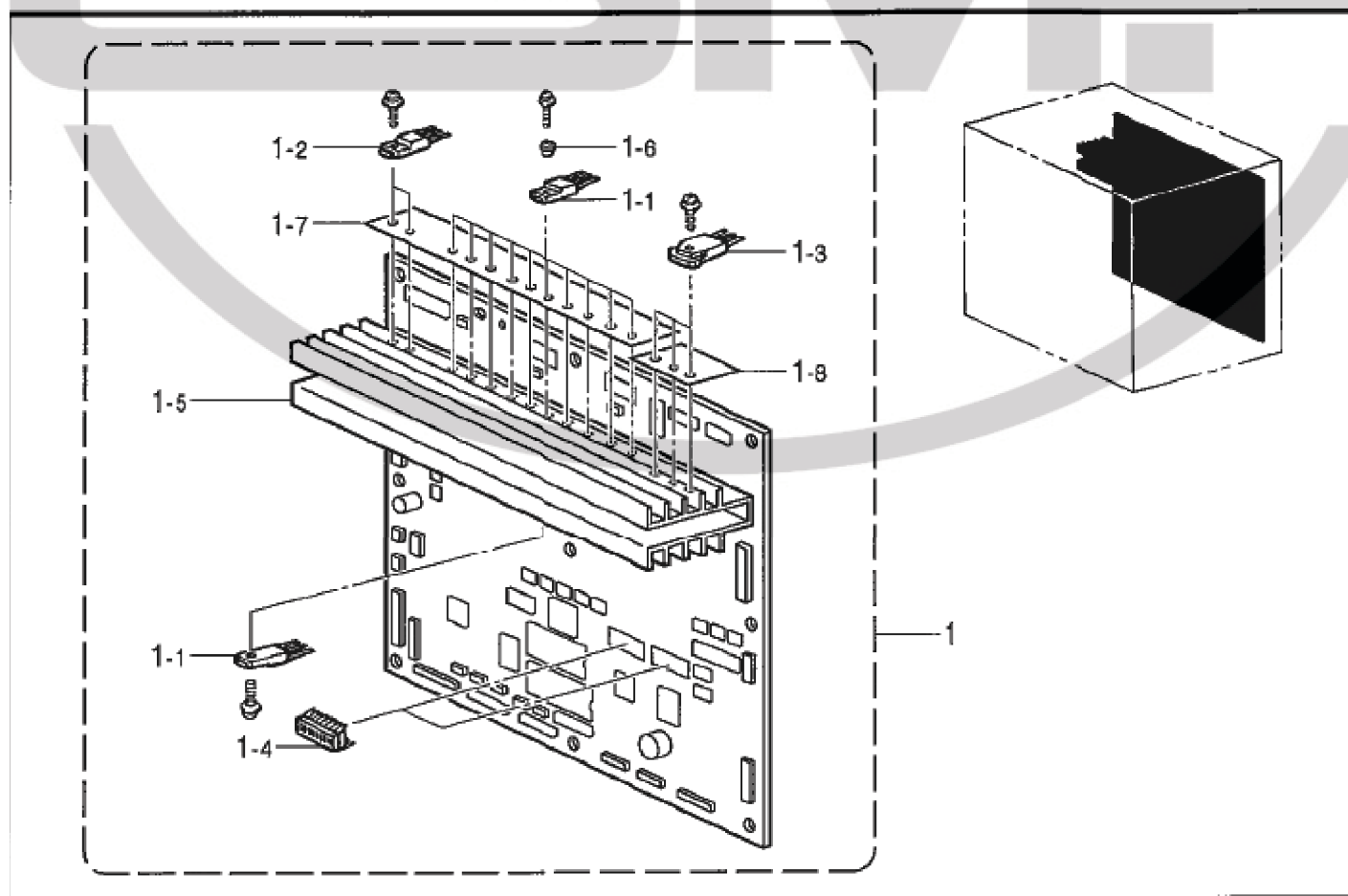

151-V41-518

P. 針位置検出器関係 / Synchronizer

REF.NO	CODE	Q'TY	ヒンメイ	NAME OF PARTS	RM
1	S48666001	1	シンクロイザクミ	SYNCHRONIZER ASSY	
2	062400806	2	ナハコ4X8	SCREW, PAN M4X8	
4	S38080001	1	ハリシタシヤクミ	NEEDLE LOWER MAGNET ASSY, D	
5	S38082001	2	ハリウイシヤクミ	NEEDLE UPPER MAGNET ASSY, U	
6	062681412	3	ナハコ4.37-40X14	SCREW, PAN SM4.37-40X14	
7	025680132	3	ヒヤサガネヨウ4.37	WASHER, PLAIN S 4.37	

151-V41-501

Q. プリント基板関係 / Printed circuit board mechanism

REF.NO	CODE	Q'TY	ヒンメイ	NAME OF PARTS	RM
1	S46449001	1	セイキキホハンクミ	CONTROL PCB ASSY	
1-1	S52243000	20	FETFK10UM-10	TRANSISTOR, FET :FK10UM-10	
1-2	S38155000	4	MOSFET2SK1306	TRANSISTOR, FET:2SK1306	
1-3	S49471000	6	MOSFETFK18SM-12	TRANSISTOR, FET:FK18SM-12	
1-4	U32744000	2	DIPSWDSS708	DIP SWITCH:DSS708	
1-5	S52250000	1	ヒートシンクB	HEATSINK, B	
1-6	S48590100	20	ブッシュBS-3-2	BUSH, BS-3-2	
1-7	S52244000	2	セグメントT220X12	INSULATION SHEET, T220X12	
1-8	S52246000	2	セグメントT3PX3	INSULATION SHEET, T3PX3	

151-V41-518

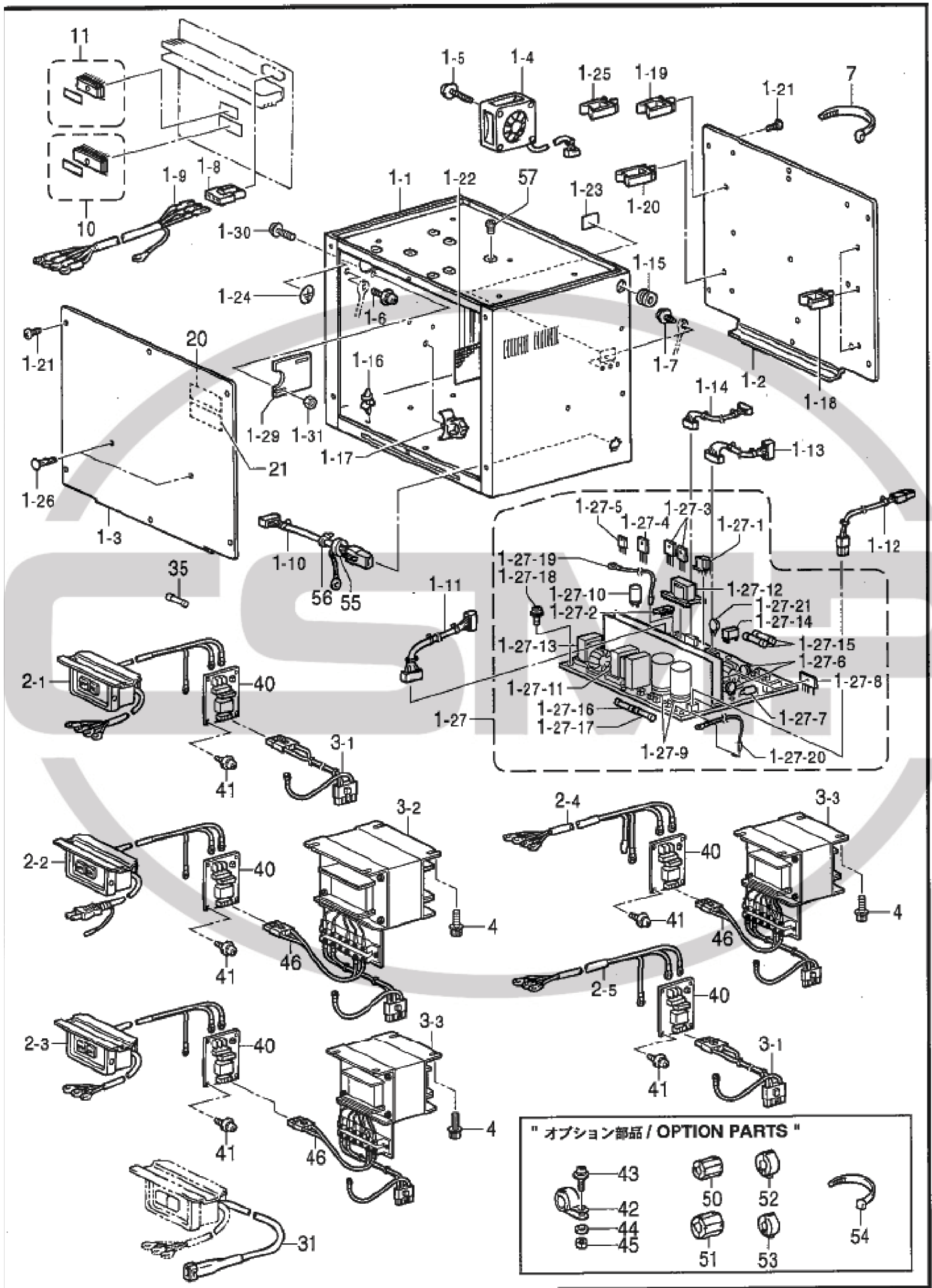

R. コントロールボックス関係 / Control box mechanism

REF.NO	CODE	Q'TY	ヒンメイ	NAME OF PARTS	RM
1	S43169109	1	ボックスキ	BOX ASSY	
1-1	S43170109	1	電源用ボックスキ	POWER SUPPLY BOX	
1-2	S43171009	1	基板用リットプレート	SETTING PLATE, PCB	
1-3	S43172009	1	ボックスキ	BOX COVER	
1-4	S38094100	2	DCファンモーター	DC-FAN MOTOR ASSY	
1-5	0A5403006	6	ボルトナット M4X30DB	SCREW, PAN (S/P WASHER) M4X30	
1-6	0A5400806	1	ボルトナット M4X8DB	SCREW, PAN (S/P WASHER) M4X8	
1-7	0A5401006	3	ボルトナット M4X10	SCREW, PAN (S/P WASHER) M4X10	
1-8	S16568000	1	コネクタ 3191-03R1	CONNECTOR :3191-03R1	
1-9	S38122200	1	モーターケーブル	MOTOR CABLE ASSY, E	
1-10	S42260000	1	フットスイッチハーネス 434	FOOT SWITCH HARNESS ASSY, 434	
1-11	S38107100	1	制御電源用ハーネス	CONTROL POWER SUPPLY HARNESS	
1-12	S38108000	1	モーター電源用ハーネス	MOTOR POWER SUPPLY HARNESS	
1-13	S38109100	1	高圧電源用ハーネス	H-P POWER SUPPLY HARNESS	
1-14	S38110000	1	電源ハーネス	POWER HARNESS	
1-15	S43186000	1	ブッシュ BU687B	BUSH, BU687B	
1-16	S00554000	18	サポート 6NS	SUPPORT, 6NS	
1-17	S31760000	1	ケーブルクリップ 26L	CORD CLAMP, 26-L	
1-18	S43275000	7	ケーブルクリップ WS2NS	CORD CLAMP, WS2NS	
1-19	S43276000	1	ケーブルクリップ WS3NS	CORD CLAMP, WS3NS	
1-20	S43277000	1	ケーブルクリップ WS4NS	CORD CLAMP, WS4NS	
1-21	008400604	12	ボルト TRUSS M4X6	SCREW, TRUSS M4X6	
1-22	S43309000	1	破片保護ネット	FRAGMENT PROTECTOR NET	
1-23	S37059001	1	ラベル PE	LABEL, PE	
1-24	S37060001	1	ラベル グラウンド	LABEL, GROUNDING	
1-25	S43318000	2	クリップ LWS8S 2.5W	CLAMP, LWS8S 2.5W	
1-26	S34413000	2	スペーサー	SPACER	
1-27	S49939101	1	電源用基板	POWER SUPPLY PCB ASSY	
1-27-1	S43177000	1	IC MA3830	IC :MA3830	
1-27-2	S43184000	2	フォトカプラー PC923	PHOTO COUPLER :PC923	
1-27-3	S49586000	2	MOSFET 2SK1941	TRANSISTOR, FET :2SK1941	
1-27-4	S55473000	1	ダイオード PA905C6-F	DIODE, AR :PA905C6-F	
1-27-5	S38203000	1	ダイオード SBDYG802C04R	DIODE :YG8022C04R	
1-27-6	SA0037000	2	バリスタ V14D511	VARIATOR:V14D511	
1-27-7	232384001	1	サージアブソーバ DSA362MA	SURGE ABSORBER :DSA362MA	
1-27-8	S49071000	1	ダイオードブリッジ 25XB60	DIODE BRIDGE :25XB60	
1-27-9	S38205000	1	コンデンサ 250B182	CAPACITOR, ALUM-ELEC 250B182	
1-27-10	SA1034000	1	コンデンサ 63B562	CAPACITOR, ALUM-ELEC 63B562	
1-27-11	S43175000	1	変圧器 54AA159	TRANSFORMER :54AA159	
1-27-12	S43176000	1	変圧器 35AD199	TRANSFORMER :35AD199	
1-27-13	S43181000	1	コイル 49AD289AC	COIL :49AD289AC	
1-27-14	S38208000	1	リレー JW1AFSND5V	RELAY :JW1AFSND/DC 5V	
1-27-15	153242000	2	ヒューズ 6A	FUSE, 6A	
1-27-16	S08030000	1	ヒューズ 5AFB	FUSE, 5A :FB	
1-27-17	S48580000	1	ヒューズ 7AFB	FUSE, 7A :FB	
1-27-18	0A4301005	8	ボルトナット M3X10DA	SCREW, PAN (S/P WASHER) M3X10	
1-27-19	S43189000	1	PCBE1ハーネス	PCB E1 HARNESS	
1-27-20	S43187000	1	PCBE2ハーネス	PCB E2 HARNESS	
1-27-21	S49472000	1	サーミスタ 6D-22	THERMISTOR :6D-22	
1-29	S38093000	1	ホルダープレート	HOLDER PLATE	
1-30	0A5401206	2	ボルトナット M4X12DB	SCREW, PAN (S/P WASHER) M4X12	
1-31	021400206	2	ナット M4	NUT, 2 M4	
2-1	S47370000	1	電源スイッチ 341A <三相200, 220, 380, 415V用>	<For 3-phase 200V, 220V, 380V, 415V>	
2-2	S47372000	1	電源スイッチ 341B <単相100V国内用>	<For Japan only>	
2-3	S47373000	1	電源スイッチ 341G <単相110, 220, 240V用>	<For 1-phase 110V, 220V, 240V>	
2-4	S47374000	1	電源スイッチ 341G <三相400V用>	<For 3-phase 400V>	
		1	電源用ハーネス E IN	POWER SUPPLY HARNESS, E IN	

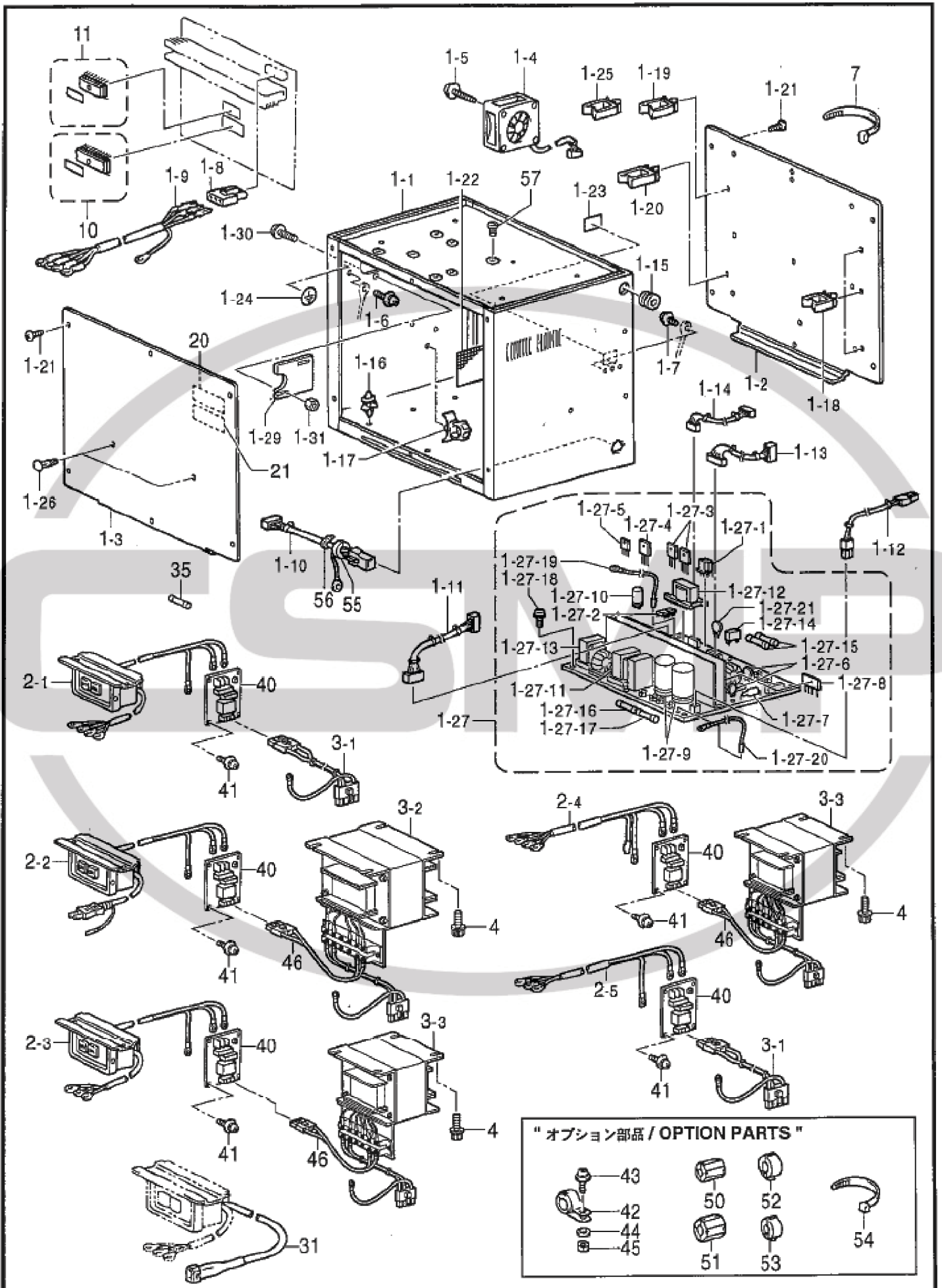

R. コントロールボックス関係 / Control box mechanism

REF.NO	CODE	Q'TY	ヒンメイ	NAME OF PARTS	RM
2-5	S47371000	1	<単相230V用> デンゲンINコートF	<For 1-phase 230V> POWER SUPPLY HARNESS, F IN	
3-1	S43201000	1	<単相220,230V 三相200,220V用> ACINコートF	<For 1-phase 220V,230V 3-phase 200V,220V> AC-IN HARNESS, F	
3-2	S43369000	1	<単相100,110V用> ハンカトランスBクミ	<For 1-phase 100,110V> CONVERSION TRANSFORMER ASSY, B	
3-3	S43370000	1	<単相240V 三相380,400,415V用> ハンカトランスCクミ	<For 1-phase 240V 3-phase 380V,400V,415V> CONVERSION TRANSFORMER ASSY, C	
4	S55476002	4	アホムトサクミ6X12	BOLT, SOCKET (S/P WASHER)M6X12	
7	228475000	4	ケツクバンド1.9X80	TYING BAND 1.9X80	
10	S49791100	1	PROMモーターV41クミ	PROM ASSY, V41 ;CONTROL	
11	S43191000	1	PROMモーター	PROM ASSY, MOTOR	
20	S38352101	2	デンゲキラベル.4カコ	LABEL, ELEC. SHOCK 4 LANG.	
21	S38353101	2	デンゲキラベル.7	LABEL, ELEC. SHOCK JPN.	
31	S43278000	1	<コンプレッサーユニット用> コンプレッサーハーネス	<For Compressor unit> COMPRESSOR HARNESS	
35	S52245000	1	GFUSE8A250FB	FUSE, 8A ;250FB	
40	S40616001	1	ノイズフィルタEMCクミ	NOISE FILTER ASSY, EMC	
41	0A4400605	4	ネジサクミ4X6DA " オプション部品"	SCREW, PAN (S/P WASHER) M4X6 "OPTION PARTS"	
42	S40623000	1	EMIコアTR-40-27	EMI CORE, TR-40-27	
43	0A5401605	1	ネジサクミ4X16DB	SCREW, PAN (S/P WASHER) M4X16	
44	025040236	1	ワッシャー平M4	WASHER, PLAIN M 4	
45	021400106	1	ナット1M4	NUT, 1 M4	
46	S40624000	1	ノイズフィルタハーネス " オプション部品"	NOISE FILTER HARNESS, A "OPTION PARTS"	
50	S40621000	1	EMIコアESD-SR-15	EMI CORE, ESD-SR-15	
51	S40622000	1	EMIコアESD-SR-25	EMI CORE, ESD-SR-25	
52	S40764000	6	コアTFC25-15-12	CORE :TFC25-15-12	
53	S42653000	2	コアTFC-23-11-14	CORE :TFC-23-11-14	
54	149809000	5	ビーズバンドL	BEAD BAND, L=200	
55	S40764000	1	コアTFC25-15-12	CORE :TFC25-15-12	
56	149809000	1	ビーズバンドL	BEAD BAND, L=200	
57	062060806	3,7	ネジサクミ6X8	SCREW, PAN M6X8	
H-1	S46440109	1	<三相200-220V用> ボックスユニットA1	<For 3-phase 200-220V> BOX UNIT, A1	*
H-2	S46441109	1	<単相100V国内用> ボックスユニットB1	<For Japan only> BOX UNIT, B1	*
H-3	S46442109	1	<三相415V用> ボックスユニットC1	<For 3-phase 415V> BOX UNIT, C1	*
H-4	S46443109	1	<単相220-230V用> ボックスユニットA2	<For 1-phase 220-230V> BOX UNIT, A2	*
H-5	S46444109	1	<三相400V用> ボックスユニットE	<For 3-phase 400V> BOX UNIT, E	*
H-6	S46445109	1	<三相380V用> ボックスユニットC2	<For 3-phase 380V> BOX UNIT, C2	*
H-7	S46446109	1	<単相230V用> ボックスユニットF	<For 1-phase 230V> BOX UNIT, F	*
H-8	S46447109	1	<単相110V用> ボックスユニットB2	<For 1-phase 110V> BOX UNIT, B2	*
H-9	S46448109	1	<単相240V用> ボックスユニットC3	<For 1-phase 240V> BOX UNIT, C3	*

151-V41-502

RM欄に*が付いている部品をご注文いただきますと、基板等必要な部品が一式入ったセットになっています。

When ordering parts which have an asterisk (*) in the RM column, these parts will be supplied as a set together with other necessary parts such as circuit boards.

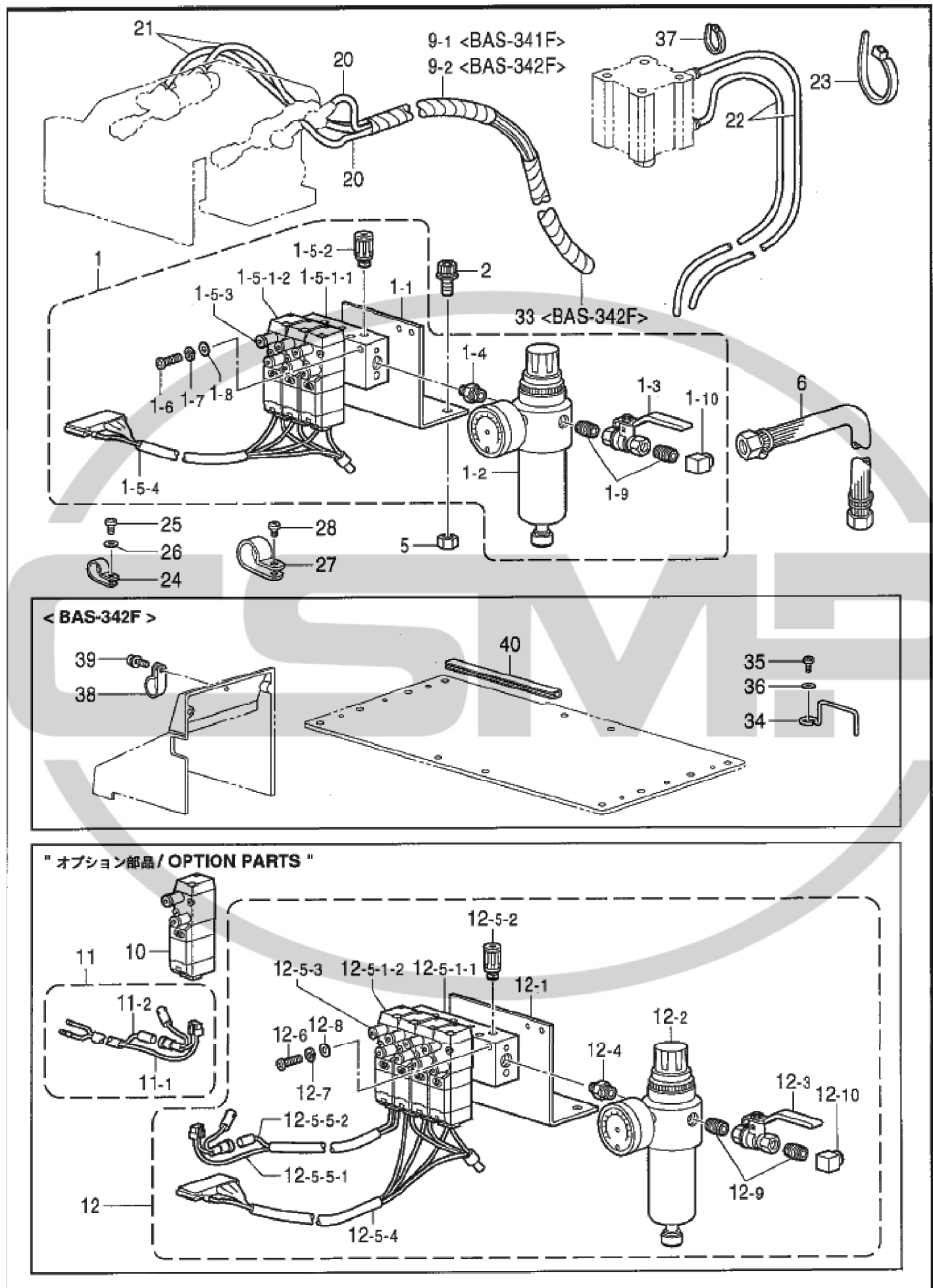

S. 空圧関係 / Air pressure mechanism

REF.NO	CODE	QTY	ヒンメイ	NAME OF PARTS	RM
1	S49429109	1	ソレノイドバルブ 3Aクミ	SOLENOID VALVE ASSY, 3A	
1-1	S31551209	1	バルブトリツケイタ2-3	SETTING PLATE, 2-3 :VALVE	
1-2	S09318101	1	インテグレータ	INTEGRATOR	
1-3	S40628000	1	ボールバルブ 1/4	BALL VALVE, 1/4	
1-4	S09228000	1	ワイニツプル	NIPPLE, 1/4X1/8	
1-5	S49430101	1	ソレノイドバルブ 3クミ	SOLENOID VALVE ASSY, 3	
1-5-1	S49431001	1	エアマニホルト 3クミ	AIR MANIFOLD ASSY, 3	
1-5-1-1	S05636001	1	エアマニホルト	AIR MANIFOLD	
1-5-1-2	S49432001	3	ソレノイドバルブ	SOLENOID VALVE	
1-5-2	S18415101	6	ハーフユニオン Q4M5	HALF UNION :Q4M5	
1-5-3	S03792001	6	ハイキックリハブ	EXHAUST THROTTLE VALVE	
1-5-4	S47166100	1	バルブハーネス X3クミ	VALVE HARNESS ASSY, X3	
1-6	062302506	2	ナット M3X25	SCREW, PAN M3X25	
1-7	028030242	2	ワッシャー 2-3	WASHER, SPRING 2-3	
1-8	025030232	2	ワッシャー M3	WASHER, PLAIN M 3	
1-9	S40629000	2	バルレルニツプル	BARREL NIPPLE	
1-10	S43686000	1	PTエルブ 1/4	ELBOW, PT 1/4	
2	S55485002	2	ボルトソケット M5X12	BOLT, SOCKET (S/P WASHER)M5X12	
5	021500106	2	ナット M5	NUT, 1 M5	
6	149796001	1	エアホースカクツキ	AIR HOSE, W/CONNECTOR	
9-1	S01565000	1	スパイラルチューブ <BAS-341F用>	<For BAS-341F> SPIRAL TUBE, 8MM L=240	
9-2	S12212000	1	スパイラルチューブ <BAS-342F用>	<For BAS-342F> SPIRAL, 290S	
			" オプション部品 "	"OPTION PARTS"	
10	S49432001	1	ソレノイドバルブ	SOLENOID VALVE	
11	S43696100	1	バルブハーネス X1クミ	VALVE HARNESS ASSY, X1	
11-1	S44746100	1	ワイカバルブハーネス	VALVE HARNESS	
11-2	S44750100	1	ワイカバルブハーネス 24V	VALVE HARNESS, 24V	
12	S49433109	1	ソレノイドバルブ 4Aクミ	SOLENOID VALVE ASSY, 4A	
12-1	S31554109	1	バルブトリツケイタ 4-5	SETTING PLATE, 4-5 :VALVE	
12-2	S09318101	1	インテグレータ	INTEGRATOR	
12-3	S40628000	1	ボールバルブ 1/4	BALL VALVE, 1/4	
12-4	S09228000	1	ワイニツプル	NIPPLE, 1/4X1/8	
12-5	S49434101	1	ソレノイドバルブ 4クミ	SOLENOID VALVE ASSY, 4	
12-5-1	S49435001	1	エアマニホルト 4クミ	AIR MANIFOLD ASSY, 4	
12-5-1-1	S18375101	1	エアマニホルト 4	AIR MANIFOLD, 4	
12-5-1-2	S49432001	4	ソレノイドバルブ	SOLENOID VALVE	
12-5-2	S18415101	8	ハーフユニオン Q4M5	HALF UNION :Q4M5	
12-5-3	S03792001	8	ハイキックリハブ	EXHAUST THROTTLE VALVE	
12-5-4	S47166100	1	バルブハーネス X3クミ	VALVE HARNESS ASSY, X3	
12-5-5	S43696100	1	バルブハーネス X1クミ	VALVE HARNESS ASSY, X1	
12-5-5-1	S44746100	1	ワイカバルブハーネス	VALVE HARNESS	
12-5-5-2	S44750100	1	ワイカバルブハーネス 24V	VALVE HARNESS, 24V	
12-6	062302506	2	ナット M3X25	SCREW, PAN M3X25	
12-7	028030242	2	ワッシャー 2-3	WASHER, SPRING 2-3	
12-8	025030232	2	ワッシャー M3	WASHER, PLAIN M 3	
12-9	S40629000	2	バルレルニツプル	BARREL NIPPLE	
12-10	S43686000	1	PTエルブ 1/4	ELBOW, PT 1/4	
20	S49057000	2	エアホース 4X2.5 U L=1900	AIR TUBE, 4X2.5 U L=1900	
21	S05792000	2	エアホース 4X2.5 L=1800	AIR TUBE, 4X2.5 L=1800	
22	S49056000	2	エアホース 4X2.5 U L=1700	AIR TUBE, 4X2.5 U L=1700	
23	149809000	1	タイラップ L	BEAD BAND, L=200	
24	S00480000	1	コードホルダ #5	CORD HOLDER, 5N	
25	062670812	1	ナット SM3.57-40X8	SCREW, PAN SM3.57-40X8	
26	025350332	1	ワッシャー L 3.5	WASHER, PLAIN L 3.5	
27	552907000	1	コードホルダ #10	CORD HOLDER, 10N	

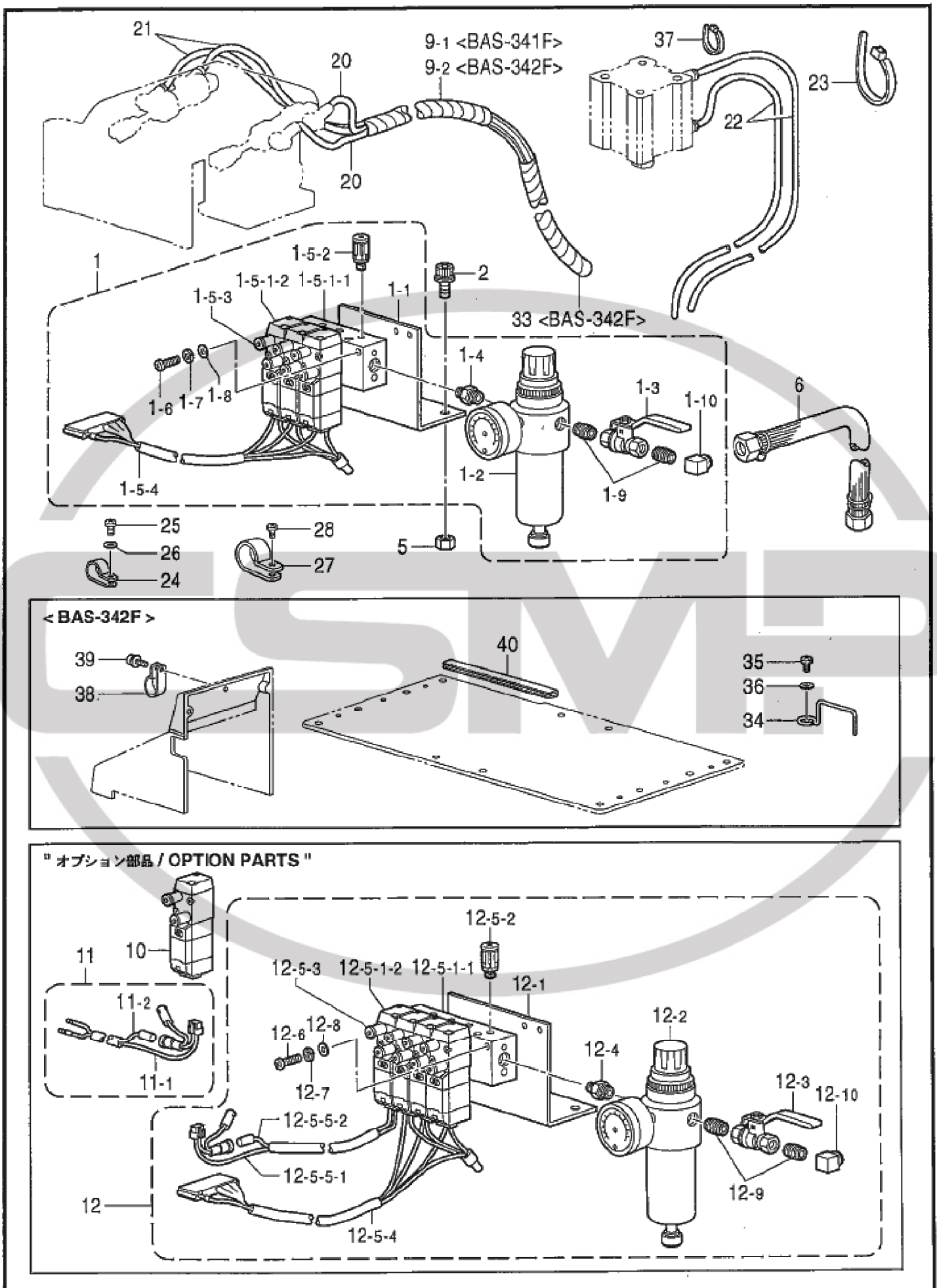

S. 空圧関係 / Air pressure mechanism

REF.NO	CODE	QTY	品名	NAME OF PARTS	RM
28	062670612	1	ナット357-40X6 <BAS-342F用>	SCREW, PAN SM3.57-40X6 <For BAS-342F>	
33	S11762000	2	スパイラル200S	SPIRAL TUBE, L=200	
34	S10232001	1	ケーブルサポ	CABLE SUPPORT	
35	062400812	1	ナット4X8	SCREW, PAN M4X8	
36	148847001	1	ワッシャー	WASHER, PLAIN 4.75	
37	228475000	1	タイイングバンド1.9X80 <BAS-342F用>	TYING BAND 1.9X80 <For BAS-342F>	
38	525664000	1	コードホルダ#6	CORD HOLDER, 6N	
39	0A5401006	1	ナットネジ4X10	SCREW, PAN (S/P WASHER) M4X10	
40	SA1911000	1	スタンダードトリム	STANDARD TRIM	

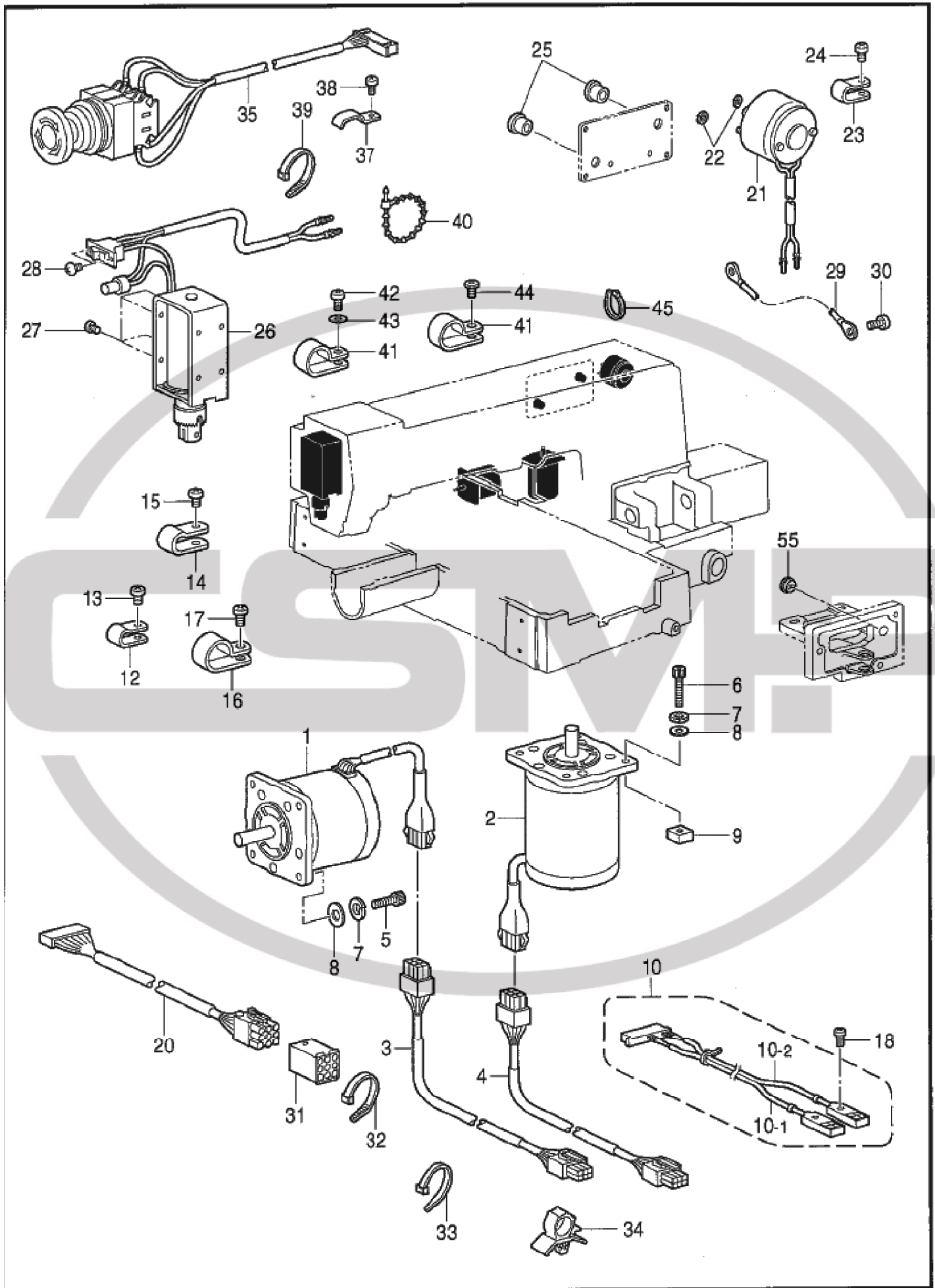

T. 電装品関係 / Power supply equipment mechanism

REF.NO	CODE	Q'TY	ヒンメイ	NAME OF PARTS	RM
1	S55594000	1	パルスモータX42クミ	PULSE MOTOR ASSY, X ;42	
2	S46433000	1	パルスモータYクミ	PULSE MOTOR ASSY, Y	
3	S46435000	1	パルスモータXハーネス	PULSE MOTOR HARNESS, X	
4	S46436000	1	パルスモータYハーネス	PULSE MOTOR HARNESS, Y	
5	018501622	4	アホ ^ホ 5X16	BOLT, SOCKET M5X16	
6	018502522	4	アホ ^ホ 5X25	BOLT, SOCKET M5X25	
7	028050242	8	ハネサ ^カ ネ2-5	WASHER, SPRING 2-5	
8	025050232	8	ヒラサ ^カ ネ1ク5	WASHER, PLAIN M 5	
9	S47167001	4	4カクナツト5	NUT, SQUARE M5	
10	S44663100	1	ケンデンセンサハーネスクミ	H-POSITION SENSOR HARNESS ASSY	
10-1	S56167000	1	キンセツセンサGL-N12F	PROXIMITY SENSOR, GL-12NF	
10-2	S56167002	1	キンセツセンサGL-N12F	PROXIMITY SENSOR, GL-12NF	
12	625010000	3	ナイロンクランプ NK-2N	NYLON CLAMP NK-2N	
13	062670612	3	ナ ^ハ コ357-40X6	SCREW, PAN SM3.57-40X6	
14	149547000	3	コト ^ホ サエ	CORD HOLDER, 4N	
15	062670612	3	ナ ^ハ コ357-40X6	SCREW, PAN SM3.57-40X6	
16	552908000	2	コト ^ホ ネタ ^ホ #14	CORD HOLDER, 14N	
17	0A5400806	2	ナ ^ハ ネ ^ホ クミ4X8DB	SCREW, PAN (S/P WASHER) M4X8	
18	002301203	2	ナ ^ハ コ3X12	SCREW, PAN M3X12	
20	S46437000	1	ソレノイドハーネスクミ	SOLENOID HARNESS ASSY	
21	S16589100	1	イトキリソレノイド	THREAD TRIMMER SOLENOID	
22	028040242	2	ハネサ ^カ ネ2.4	WASHER, SPRING 2-4	
23	S10243000	1	ナイロンクランプ NK-3N	CORD HOLDER, NK-3N	
24	062670612	1	ナ ^ハ コ357-40X6	SCREW, PAN SM3.57-40X6	
25	146080000	2	コト ^ホ ブシ	CORD BUSH	
26	S41202151	1	イトハラソレノイドクミ	THREAD WIPER SOLENOID ASSY	
27	062300616	4	ナ ^ハ コM3X6	SCREW, PAN M3X6	
28	S55184000	2	トラスコ3X6	SCREW, TRUSS M3X6	
29	S46439000	1	ア-セン1	GRUNDING WIRE, 1	
30	062670612	1	ナ ^ハ コ357-40X6	SCREW, PAN SM3.57-40X6	
31	S57926000	1	コネクタ3191-09P1	CONNECTOR, 3191-09P1	
32	149809000	1	タイラツ ^ホ L	BEAD BAND, L=200	
33	S06143000	1	ハンタイPLT4S	BAND, PLT4S	
34	S04505000	1	CKSクランプ13-H	CORD CLAMP, 13-H	
35	SA1584000	1	EMロックスイッチクミ	EM-LOCK SWITCH ASSY	
37	142268001	2	コト ^ホ サエL	CORD HOLDER, L	
38	062670612	2	ナ ^ハ コ357-40X6	SCREW, PAN SM3.57-40X6	
39	228475000	2	ケツクハント ^ホ 1.9X80	TYING BAND 1.9X80	
40	340400001	4	エタイハント ^ホ	BEAD BAND	
41	552907000	2	コト ^ホ ネタ ^ホ #10	CORD HOLDER, 10N	
42	062670812	1	ナ ^ハ コ3.57-40X8	SCREW, PAN SM3.57-40X8	
43	025350332	1	ヒラサ ^カ ネ13.5	WASHER, PLAIN L 3.5	
44	060670612	1	ナ ^ハ コ357-40X6	SCREW, BIND SM3.57-40X6	
45	228475000	1	ケツクハント ^ホ 1.9X80	TYING BAND 1.9X80	
55	146020001	1	コト ^ホ ブシ	CORD BUSH	

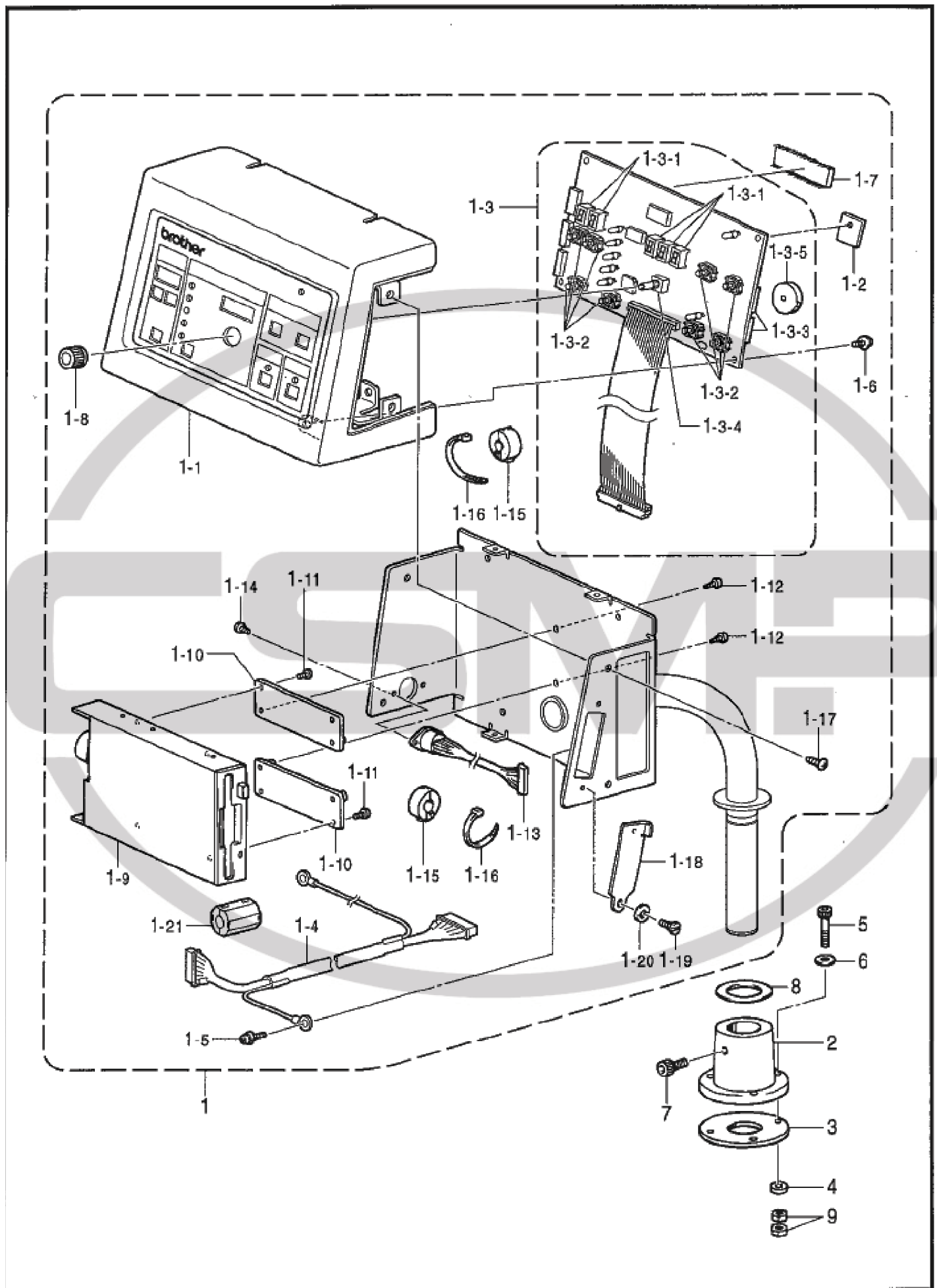

U. 操作パネル関係 / Operation panel mechanism

REF.NO	CODE	QTY	ヒンメイ	NAME OF PARTS	RM
1	S58851001	1	ソウサバネルキミ	OPERATION PANEL ASSY	
1-1	S55154001	1	ソウサバネルマヱキミ	OPERATION PANEL FRONT ASSY	
1-2	S49938000	1	セツインシート	INSULATION SHEET	
1-3	S56151000	1	ハネルキハシキミ	PANEL PCB ASSY	
1-3-1	S29023000	5	LEDGL9P040	LED :GL9P040	
1-3-2	S48579000	8	SWB3F-4050	SWITCH :B3F-4050	
1-3-3	U34870001	2	DIPSW KSP08	DIP SWITCH:KSP08	
1-3-4	S38104000	1	エンコーダEVQVEMF01	ENCODER, EVQVEMF01	
1-3-5	417382001	1	PKB24SC-3601	BUZZER:PKB24SC-3601	
1-4	S55402200	1	ハネルキハシキミ	PANEL HARNESS ASSY	
1-5	0A5400805	1	ナハネサキキミ4X8DB	SCREW, PAN (S/P WASHER) M4X8	
1-6	0A4300605	4	ナハネサキキミ3X6DA	SCREW, PAN (S/P WASHER) M3X6	
1-7	S43237100	1	PROMハネルキミ	PROM ASSY, PANEL	
1-8	S02907000	1	ツマミ	KNOB	
1-9	S43224000	1	3.5FDD	FDD, 3.5	
1-10	S43225000	2	FDDスパーサ	SPACER, FDD	
1-11	0A4300605	4	ナハネサキキミ3X6DA	SCREW, PAN (S/P WASHER) M3X6	
1-12	037300816	4	Vナハネツビ3X8	TAPPING SCREW, PAN V M3X8	
1-13	S43228000	1	プログラマコートPキミ	PROGRAMMER HARNESS ASSY, P	
1-14	002300603	2	ナハネ3X6	SCREW, PAN M3X6	
1-15	S42653000	2	コアTFC-23-11-14	CORE :TFC-23-11-14	
1-16	149809000	2	タイラツツL	BEAD BAND, L=200	
1-17	S55151000	12	ナハネサキキミ4X6	SCREW, TRUSS M4X6	
1-18	S36008009	1	ハネルキコカハ	SIDE COVER, PANEL	
1-19	107321009	1	タネネシ4.76	SHOULDER SCREW, SM4.76	
1-20	107017001	1	ナミハネサキカネ	WAVE WASHER	
1-21	S51241000	1	EMIコアE1630MRF	CORE, EMI :E1630MRF	
2	S43236009	1	ソウサバネルキミ	OPERATION PANEL BASE	
3	S43674000	1	クッションA	CUSHION, A	
4	S43675000	3	クッションB	CUSHION, B	
5	S25634101	3	ナハネサキキミ5X65	BOLT, SOCKET M5X65	
6	025050236	6	ヒラサキネチキミ5	WASHER, PLAIN M 5	
7	018081636	1	ナハネサキキミ8X16	BOLT, SOCKET M8X16	
8	S10408000	1	ゴムシート	RUBBER SHEET	
9	021500106	6	ナミサキキミ5	NUT, 1 M5	

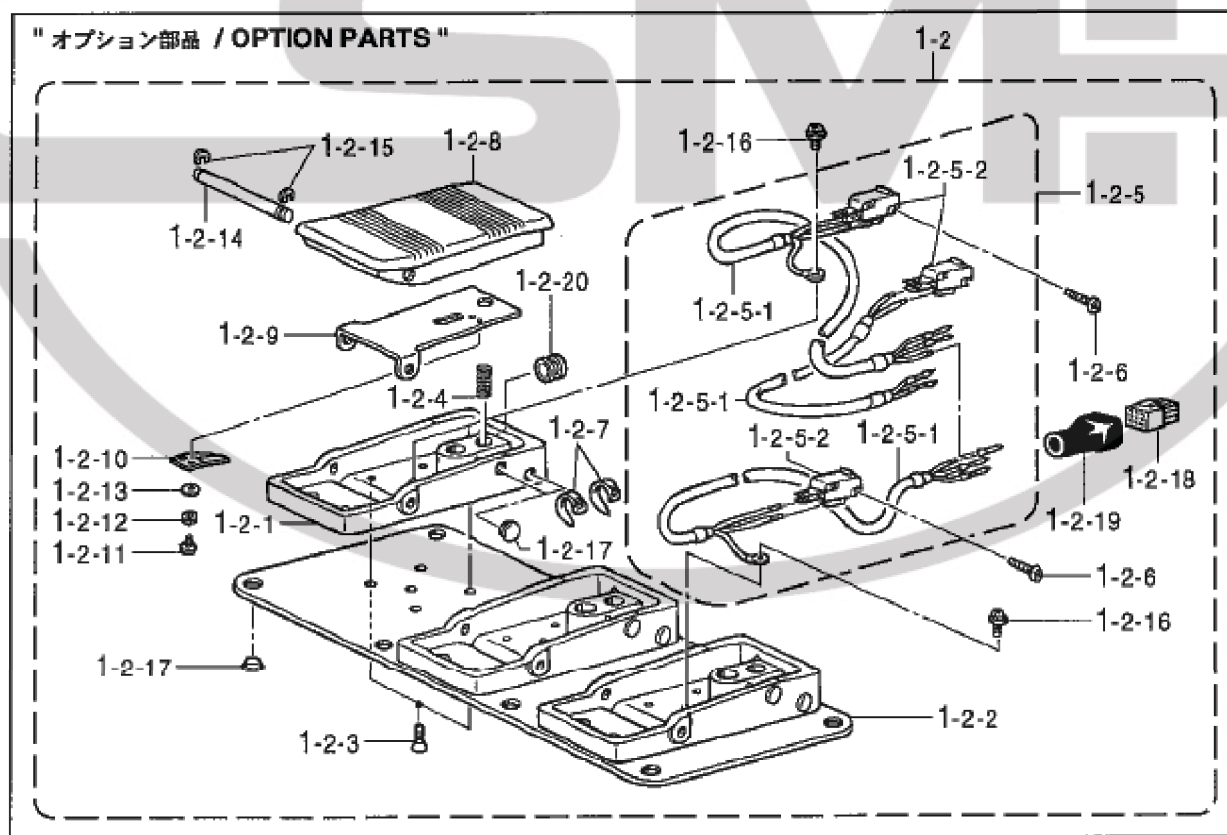
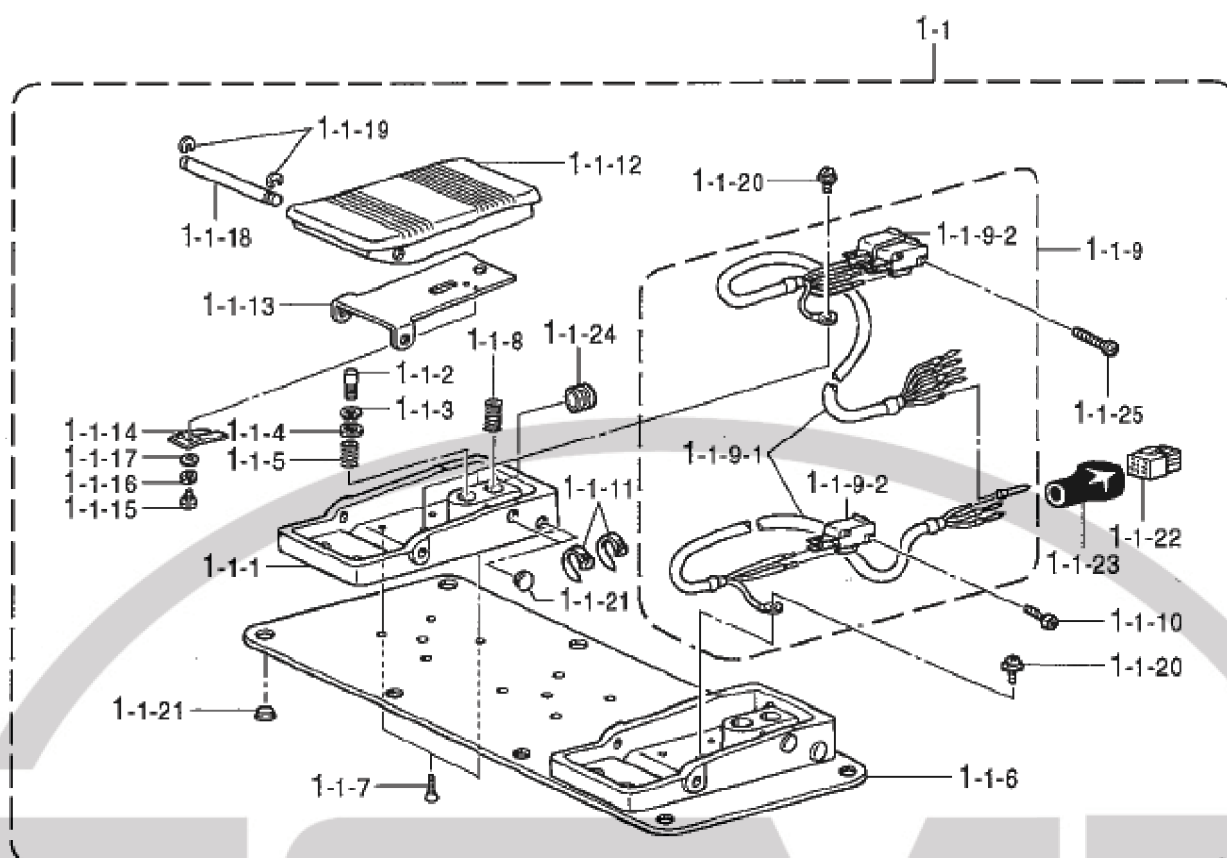

"オプション部品 / OPTION PARTS"



V. 踏板関係 / Foot switch pedal mechanism

REF.NO	CODE	QTY	ヒンメイ	NAME OF PARTS	RM
1-1	S42842101	1	2レソフツ3SW	2-PEDAL FOOT SWITCH, 3	
1-1-1	S38166000	2	フツヘ'タル'イ	FOOT PEDAL BASE	
1-1-2	S38167001	1	2タ'ンSWヒ'ン	SWITCH PIN, 2-STEP	
1-1-3	048060142	1	トメワシ'クヨ C6	RETAINING RING, EXTERNAL C6	
1-1-4	025060236	1	ヒラサ'ガ'ネ'ユ'6	WASHER, PLAIN M 6	
1-1-5	S38168001	1	アツシ'ユ'ハ'ネ	SPRING, COMPRESSION 10X30	
1-1-6	S42867001	1	アミ'タ'シ'ヨ'イ'タ	TREADLE AUXILIARY PLATE	
1-1-7	004400603	4	サ'ラ'コ'ネ'シ' 4X6	SCREW, FLAT M4X6	
1-1-8	S38170001	2	フツヘ'タ'ル'ハ'ネ	FOOT PEDAL SPRING	
1-1-9	S42259000	1	2レソフツ3SWハ'ネ'スク'ミ	2-PEDAL FOOT SW HARN. ASSY, 3	
1-1-9-1	S42258000	1	2レソフツ3SWハ'ネ'ス	2-PEDAL FOOT SW HARNESS, 3	
1-1-9-2	S36260000	3	スイツ'チ'V'X'ヒ'ン'ホ'タン	MICRO SWITCH, VX :PIN BUTTON	
1-1-10	062301205	2	ナ'ハ'コ'3X12	SCREW, PAN M3X12	
1-1-11	228475000	10	ケツ'ソ'カ'ハ'ント' 1.9X80	TYING BAND 1.9X80	
1-1-12	S38174000	2	フツヘ'タ'ル	FOOT PEDAL	
1-1-13	S38175001	2	ハ'タ'ル'ホ'コ'イ'タ	PROTECTION PLATE, PEDAL	
1-1-14	S38176101	2	スイツ'チ'サ'イ'ハ'ネ	SPRING, PLATE	
1-1-15	002300403	4	ナ'ハ'コ'3X4	SCREW, PAN M3X4	
1-1-16	028030246	4	ハ'ネ'サ'ガ'ネ'2-3	WASHER, SPRING 2-3	
1-1-17	025030236	4	ヒラサ'ガ'ネ'ユ'3	WASHER, PLAIN M 3	
1-1-18	S38177001	2	フツヘ'タ'ル'シ'ク	FOOT PEDAL SHAFT	
1-1-19	048050346	4	トメ'ワ'E5	RETAINING RING, E5	
1-1-20	052400606	2	ナ'ハ'コ'ネ'ヒ'ラ'4X6	SCREW, PAN (S/P WASHER) M4X6	
1-1-21	117936001	12	ゴ'ム'セ'ン'9.4	RUBBER CAP, 9.4	
1-1-22	S38180000	1	コ'ネ'ク'タ'172169-1	CONNECTOR :172169-1	
1-1-23	S38060000	1	コ'ネ'ク'タ'キ'ヤ'ツ'フ' 18X19	CONNECTOR CAP, 18X19	
1-1-24	S38059000	2	ク'ロ'メ'カ'ト'NG79F	RUBBER CAP, NG79F	
1-1-25	062302506	2	ナ'ハ'コ'3X25	SCREW, PAN M3X25	
			" オプション部品 "	"OPTION PARTS"	
1-2	S44805101	1	3レソフツ3SW	3-PEDAL FOOT SWITCH, 3	
1-2-1	S38166000	3	フツヘ'タル'イ	FOOT PEDAL BASE	
1-2-2	S42867001	1	アミ'タ'シ'ヨ'イ'タ	TREADLE AUXILIARY PLATE	
1-2-3	004400603	6	サ'ラ'コ'ネ'シ' 4X6	SCREW, FLAT M4X6	
1-2-4	S38170001	3	フツヘ'タ'ル'ハ'ネ	FOOT PEDAL SPRING	
1-2-5	S44806000	1	3レソフツ3SWハ'ネ'スク'ミ	3-PEDAL FOOT SW HARNESS ASSY	
1-2-5-1	S44807000	1	3レソフツ3SWハ'ネ'ス	3-PEDAL FOOT SW HARNESS	
1-2-5-2	S36260000	3	スイツ'チ'V'X'ヒ'ン'ホ'タン	MICRO SWITCH, VX :PIN BUTTON	
1-2-6	062301205	6	ナ'ハ'コ'3X12	SCREW, PAN M3X12	
1-2-7	228475000	10	ケツ'ソ'カ'ハ'ント' 1.9X80	TYING BAND 1.9X80	
1-2-8	S38174000	3	フツヘ'タ'ル	FOOT PEDAL	
1-2-9	S38175001	3	ハ'タ'ル'ホ'コ'イ'タ	PROTECTION PLATE, PEDAL	
1-2-10	S38176101	3	スイツ'チ'サ'イ'ハ'ネ	SPRING, PLATE	
1-2-11	002300403	6	ナ'ハ'コ'3X4	SCREW, PAN M3X4	
1-2-12	028030246	6	ハ'ネ'サ'ガ'ネ'2-3	WASHER, SPRING 2-3	
1-2-13	025030236	6	ヒラサ'ガ'ネ'ユ'3	WASHER, PLAIN M 3	
1-2-14	S38177001	3	フツヘ'タ'ル'シ'ク	FOOT PEDAL SHAFT	
1-2-15	048050346	6	トメ'ワ'E5	RETAINING RING, E5	
1-2-16	052400606	2	ナ'ハ'コ'ネ'ヒ'ラ'4X6	SCREW, PAN (S/P WASHER) M4X6	
1-2-17	117936001	14	ゴ'ム'セ'ン'9.4	RUBBER CAP, 9.4	
1-2-18	S38180000	1	コ'ネ'ク'タ'172169-1	CONNECTOR :172169-1	
1-2-19	S38060000	1	コ'ネ'ク'タ'キ'ヤ'ツ'フ' 18X19	CONNECTOR CAP, 18X19	
1-2-20	S38059000	3	ク'ロ'メ'カ'ト'NG79F	RUBBER CAP, NG79F	
			" 補給用部品 "	"For supply parts"	
3	S49443000	1	コ'ン'タ'ク'ト'170364-1	CONTACT :170364-1	

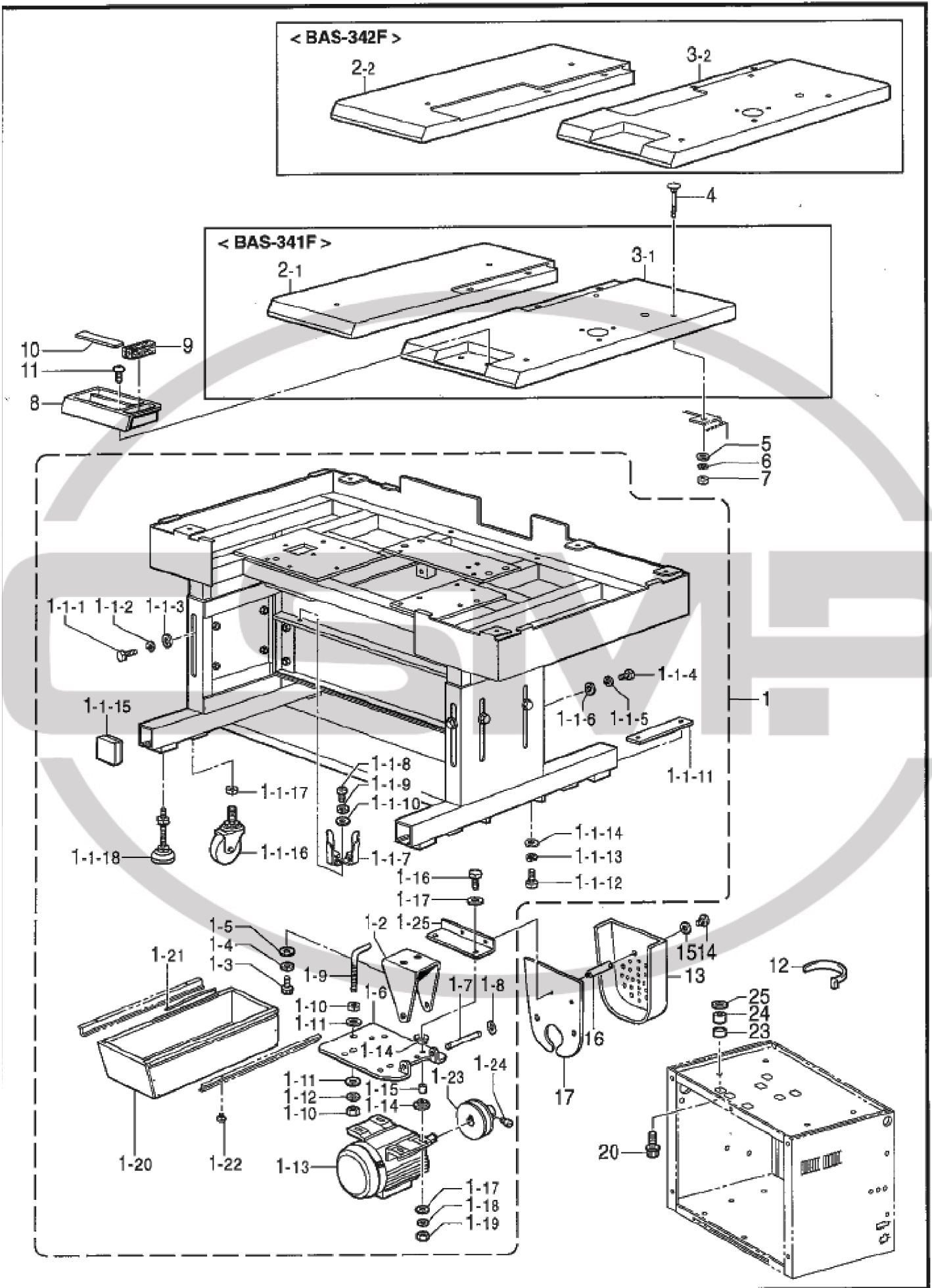

W. 動力台関係 / Power table

REF.NO	CODE	Q'TY	ヒンメイ	NAME OF PARTS	RM
1	S47154109	1	テーブルスタンド	TABLE STAND ASSY	
1-1-1	017101606	6	ボルトM10X16	BOLT, M10X16	
1-1-2	028100246	6	ワッシャー カンテ-10	WASHER, SPRING 2-10	
1-1-3	025100236	6	ワッシャー カンテ10	WASHER, PLAIN L 10	
1-1-4	017101606	4	ボルトM10X16	BOLT, M10X16	
1-1-5	028100246	4	ワッシャー カンテ-10	WASHER, SPRING 2-10	
1-1-6	025100236	4	ワッシャー カンテ10	WASHER, PLAIN L 10	
1-1-7	133172003	1	ブラケット	BRACKET, OIL	
1-1-8	037521016	1	タップスクリュー 2x15	TAPPING SCREW, PAN 2 M5.2X10	
1-1-9	028050246	4	ワッシャー カンテ-5	WASHER, SPRING 2-5	
1-1-10	025050236	4	ワッシャー カンテ5	WASHER, PLAIN M 5	
1-1-11	S17994001	2	ナット	NUT	
1-1-12	017102006	4	ボルトM10X20	BOLT, M10X20	
1-1-13	028100246	4	ワッシャー カンテ-10	WASHER, SPRING 2-10	
1-1-14	025100236	4	ワッシャー カンテ10	WASHER, PLAIN L 10	
1-1-15	S10661109	4	ゴムパッキン	RUBBER	
1-1-16	S06715002	4	キャスター	CASTER	
1-1-17	021160306	4	ナットM16	NUT, 3 M16	
1-1-18	S04754000	4	レベル調整器	LEVEL ADJUSTER	
1-2	S17997001	1	モーターベース調整プレート	MOTOR BASE SETTING PLATE	
1-3	018081622	2	ボルトソケットM8X16	BOLT, SOCKET M8X16	
1-4	028080242	2	ワッシャー カンテ-8	WASHER, SPRING 2-8	
1-5	025080232	2	ワッシャー カンテ8	WASHER, PLAIN M 8	
1-6	152861101	1	モーターベースプレート	MOTOR BASE PLATE	
1-7	152862001	1	モーターベースプレートシャフト	MOTOR BASE PLATE SHAFT	
1-8	048100142	2	リテーニングリング 外部C10	RETAINING RING, EXTERNAL C10	
1-9	152865201	1	ボルト L型M10	BOLT, L-TYPE M10	
1-10	021100202	2	ナットM10	NUT, 2 M10	
1-11	025100132	2	ワッシャー カンテ10	WASHER, PLAIN S 10	
1-12	028100242	1	ワッシャー カンテ-10	WASHER, SPRING 2-10	
1-13	S46460000	1	3相モーター200V	3-PHASE MOTOR 200V AC-400W	
1-14	152864000	8	クッション	CUSHION	
1-15	152863001	4	クッションカラー	CUSHION COLLAR	
1-16	017062503	4	ボルトM6X25	BOLT, M6X25	
1-17	025800332	10	ワッシャー カンテ 17, 14	WASHER, PLAIN L 7.14	
1-18	028060242	4	ワッシャー カンテ-6	WASHER, SPRING 2-6	
1-19	021060102	4	ナットM6	NUT, 1 M6	
1-20	S18103001	1	サイド Drawer	SIDE DRAWER	
1-21	101073001	1	スプリング	SPRING	
1-22	062300512	4	スクリュー M3X5	SCREW, PAN M3X5	
1-23	S38041000	1	モータープーリー	MOTOR PULLEY	
1-24	105073001	1	セットスクリュー SM5.95	SET SCREW, SM5.95	
1-25	S20953001	1	モーターカバーサポート	MOTOR COVER SUPPORT	
			<BAS-341F用>	<For BAS-341F>	
2-1	S47161109	1	テーブル L	TABLE, L	
3-1	S47162109	1	テーブル R	TABLE, R	
			<BAS-342F用>	<For BAS-342F>	
2-2	S47328009	1	テーブル L 342	TABLE, L 342	
3-2	S47329009	1	テーブル R 342	TABLE, R 342	
4	119755001	5	ボルトM6X60	BOLT, M6X60	
5	025060232	5	ワッシャー カンテ10	WASHER, PLAIN M 6	
6	028060242	5	ワッシャー カンテ-6	WASHER, SPRING 2-6	
7	021060102	5	ナットM6	NUT, 1 M6	
8	S15158009	1	アクセサリーケース	ACCESSORY CASE	
9	S02740000	1	フェルト	FELT	
10	S02739000	1	ゴムシヤクテープ	RUBBER MAGNET TAPE	
11	039411215	2	タップスクリュー 4X12	TAPPING SCREW, TRUSS 1 M4X12	
12	S06143000	2	バンド PLT4S	BAND, PLT4S	

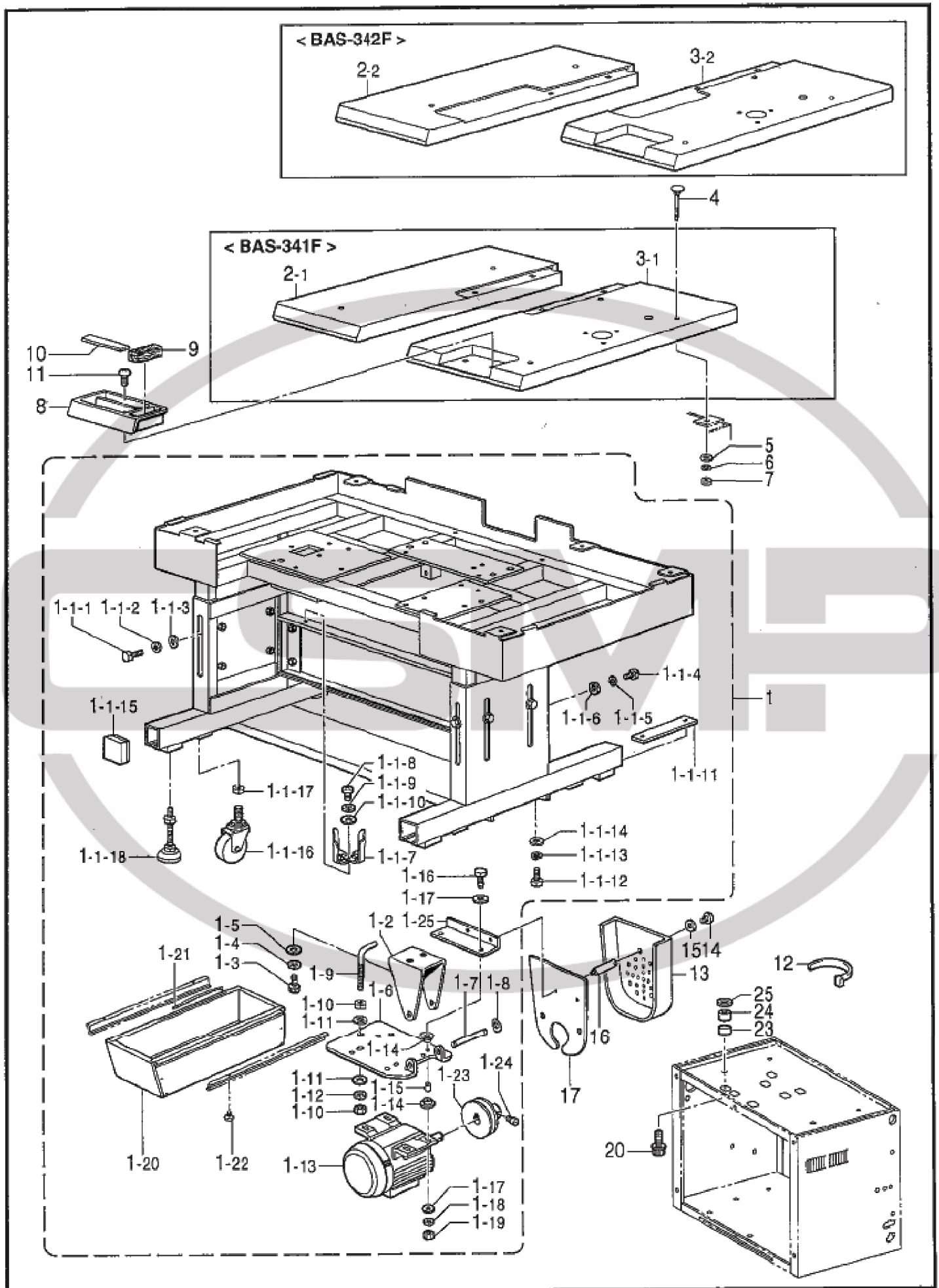

W. 動力台関係 / Power table

REF.NO	CODE	QTY	ヒンメイ	NAME OF PARTS	RM
13	S18344209	1	モータカバー	MOTOR COVER	
14	062711012	2	ナットM4.76-32X10	SCREW, PAN SM4.76-32X10	
15	025710232	2	ワッシャーネジM4.76	WASHER, PLAIN M 4.76	
16	S53182101	2	ベルトカバーシチュウ	STUD, BELT COVER	
17	S20952101	1	モータ後カバー	MOTOR REAR COVER	
20	S47270001	4	ボルトソケット(ワッシャー)M6X30	BOLT, SOCKET (S/P WASHER)M6X30	
23	146256001	4	クッションカバー	CUSHION COLLAR	
24	146255000	4	クッション	CUSHION	
25	S00617000	4	ボウシゴムカラー	RUBBER COLLAR	

X1 . 中押工反転装置関係 (オプション部品: 縫製エリア100×60mm)
 / Inner clamping device (Option parts : Sewing area 100×60mm)

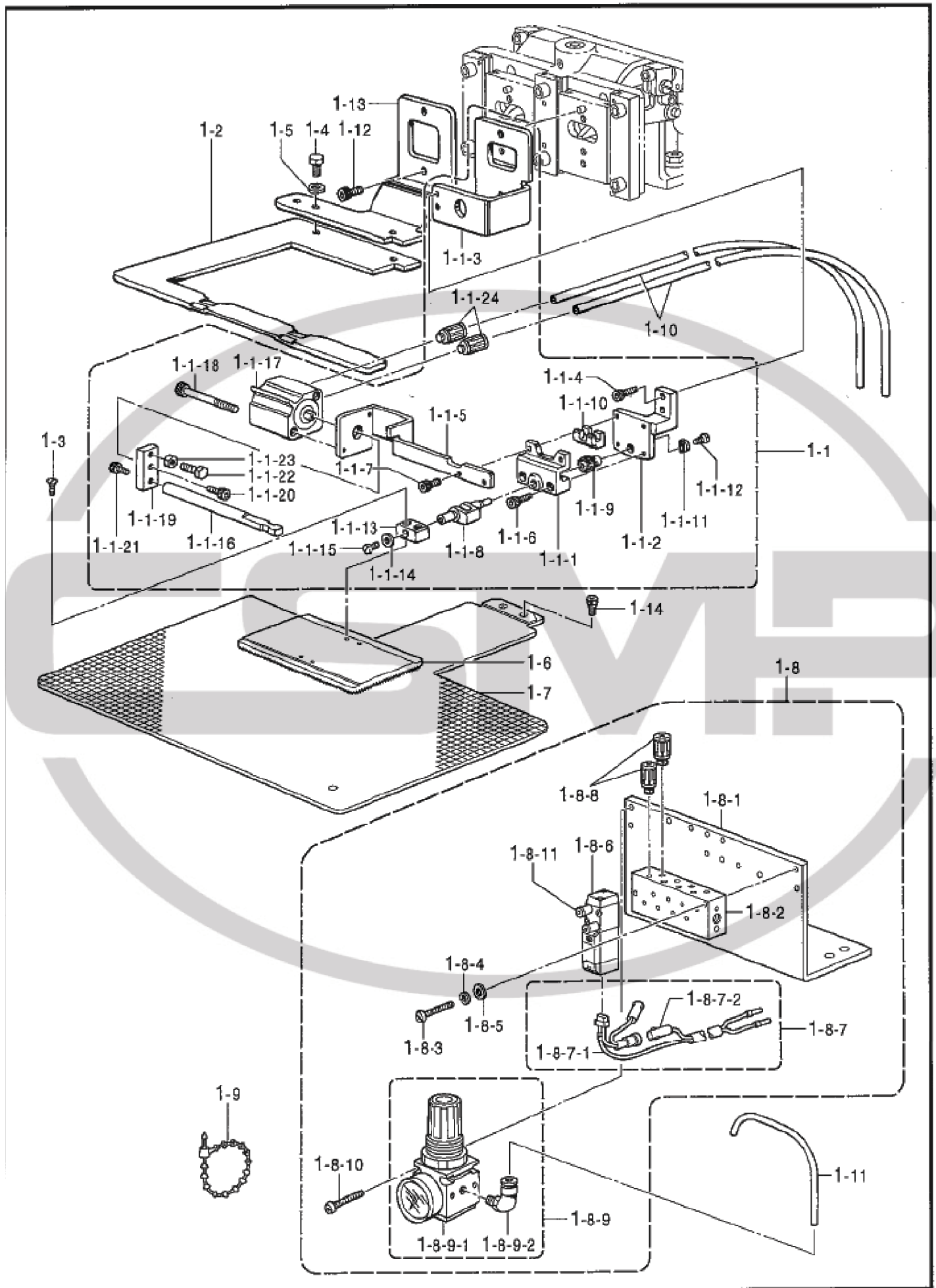

X1. 中押工反転装置関係 (オプション部品：縫製エリア100X60mm)

/ Inner clamping device (Option parts : Sewing area 100X60 mm)

REF.NO	CODE	QTY	ヒンメイ	NAME OF PARTS	RM
1	S48507109	1	ハテンウチセット	INNER CLAMPING DEVICE SET	
1-1	S19997109	1	オサイクランクLAクミ	WORK CLAMP CRANK ASSY, LA	
1-1-1	S12634009	1	オサイクランクホルダ A	WORK CLAMP CRANK HOLDER, A	
1-1-2	S12635009	1	オサイクランクホルダ B	WORK CLAMP CRANK HOLDER, B	
1-1-3	S19998001	1	オサエアH	WORK CLAMP, H	
1-1-4	018681232	2	アホ ㊦437-40X12	BOLT, SOCKET SM4.37-40X12	
1-1-5	S12638009	1	ハテンリクタ ㊦	REVERSE CYLINDER BRACKET	
1-1-6	018301236	2	アホ ㊦3X12	BOLT, SOCKET M3X12	
1-1-7	018301036	2	アホ ㊦3X10	BOLT, SOCKET M3X10	
1-1-8	S05865001	1	オサイクランクLA	WORK CLAMP CRANK, LA	
1-1-9	154235001	1	ハテンギヤ	REVERSE GEAR	
1-1-10	154236001	1	ハテンアーク	REVERSE RACK	
1-1-11	145087001	1	ハテンギヤサガネ	WASHER	
1-1-12	149831101	1	アタマツボメネジ 3.18	SET SCREW, SM3.18	
1-1-13	154237001	1	オサイクランクL	WORK CLAMP PLATE HOLDER, L	
1-1-14	025350132	1	ヒラサガネシヨウ	WASHER, PLAIN S 3.5	
1-1-15	100242003	1	シメネジ 3.57	SCREW, SM3.57-40X5	
1-1-16	S12637009	1	ハテンロッド	REVERSE ROD	
1-1-17	S12639001	1	ハテンリクタ	REVERSE CYLINDER	
1-1-18	S12642009	2	アホ ㊦3X35	BOLT, SOCKET M3X35	
1-1-19	S12640009	1	ハテンクワキテ	JOINT	
1-1-20	018300836	1	アホ ㊦3X8	BOLT, SOCKET M3X8	
1-1-21	018300836	1	アホ ㊦3X8	BOLT, SOCKET M3X8	
1-1-22	017501216	1	ホ ㊦5X12	BOLT, M5X12	
1-1-23	021500216	1	ジュナツト5	NUT, 2 M5	
1-1-24	S18415101	2	ハーフユニオンQ4M5	HALF UNION :Q4M5	
1-2	S20000001	1	ソトオサイクラ-H1	WORK CLAMP, EXTERNAL-H1	
1-3	117291002	2	サラネジ 3.18	SCREW, FLAT SM3.18	
1-4	153403002	2	ホ ㊦4.37X7	BOLT, SM4.37X7	
1-5	025680232	2	ヒラサガネシヨウ4.37	WASHER, PLAIN M 4.37	
1-6	154256101	1	オサイクランクA	WORK CLAMP PLATE BLANK, A	
1-7	S48509001	1	オサイクランクH-A	FEED PLATE BLANK, H-A	
1-8	S49436109	1	ハテンバルブ4クミ	VALVE ASSY, 4 ;IN-CLAMP	
1-8-1	S31570409	1	バルブトリツケイタ4-5H	VALVE SETTING PLATE, 4-5H	
1-8-2	S18375101	1	エアマニホールド4	AIR MANIFOLD, 4	
1-8-3	062302505	2	ナハ 3X25	SCREW, PAN M3X25	
1-8-4	028030242	2	ハネサガネ2-3	WASHER, SPRING 2-3	
1-8-5	025030232	2	ヒラサガネシヨウ3	WASHER, PLAIN M 3	
1-8-6	S49432001	1	ソレノイドバルブ	SOLENOID VALVE	
1-8-7	S43696100	1	バルブハーネスX1クミ	VALVE HARNESS ASSY, X1	
1-8-7-1	S44746100	1	ツイカバルブハーネス	VALVE HARNESS	
1-8-7-2	S44750100	1	ツイカバルブハーネス24V	VALVE HARNESS, 24V	
1-8-8	S18415101	2	ハーフユニオンQ4M5	HALF UNION :Q4M5	
1-8-9	S45252000	1	レギュレータークミ	REGULATOR ASSY	
1-8-9-1	S45253000	1	レギュレーター	REGULATOR	
1-8-9-2	S45254000	2	クワキテ3109-4-10	JOINT, 3109-4-10	
1-8-10	062404005	2	ナハ 4X40	SCREW, PAN M4X40	
1-8-11	S03792001	2	エキシネーションバルブ	EXHAUST THROTTLE VALVE	
1-9	340400001	2	ビーズバンド	BEAD BAND	
1-10	S15031008	2	エアチューブ	AIR TUBE, 4X2.5 L=1900	
1-11	S20006000	1	ウレタンチューブS	URETHANE TUBE, S	
1-12	018501222	2	アホ ㊦5X12	BOLT, SOCKET M5X12	
1-13	S19999001	1	オサエアSEL-H	WORK CLAMP, SEL-H	
1-14	S10352101	2	オサイクランクシメネジ	SCREW, ROUND W/SOCKET SM4.37	

X2. 中押工反転装置関係 (オプション部品: 縫製エリア250×150mm)
 / Inner clamping device (Option parts : Sewing area 250 X 150mm)

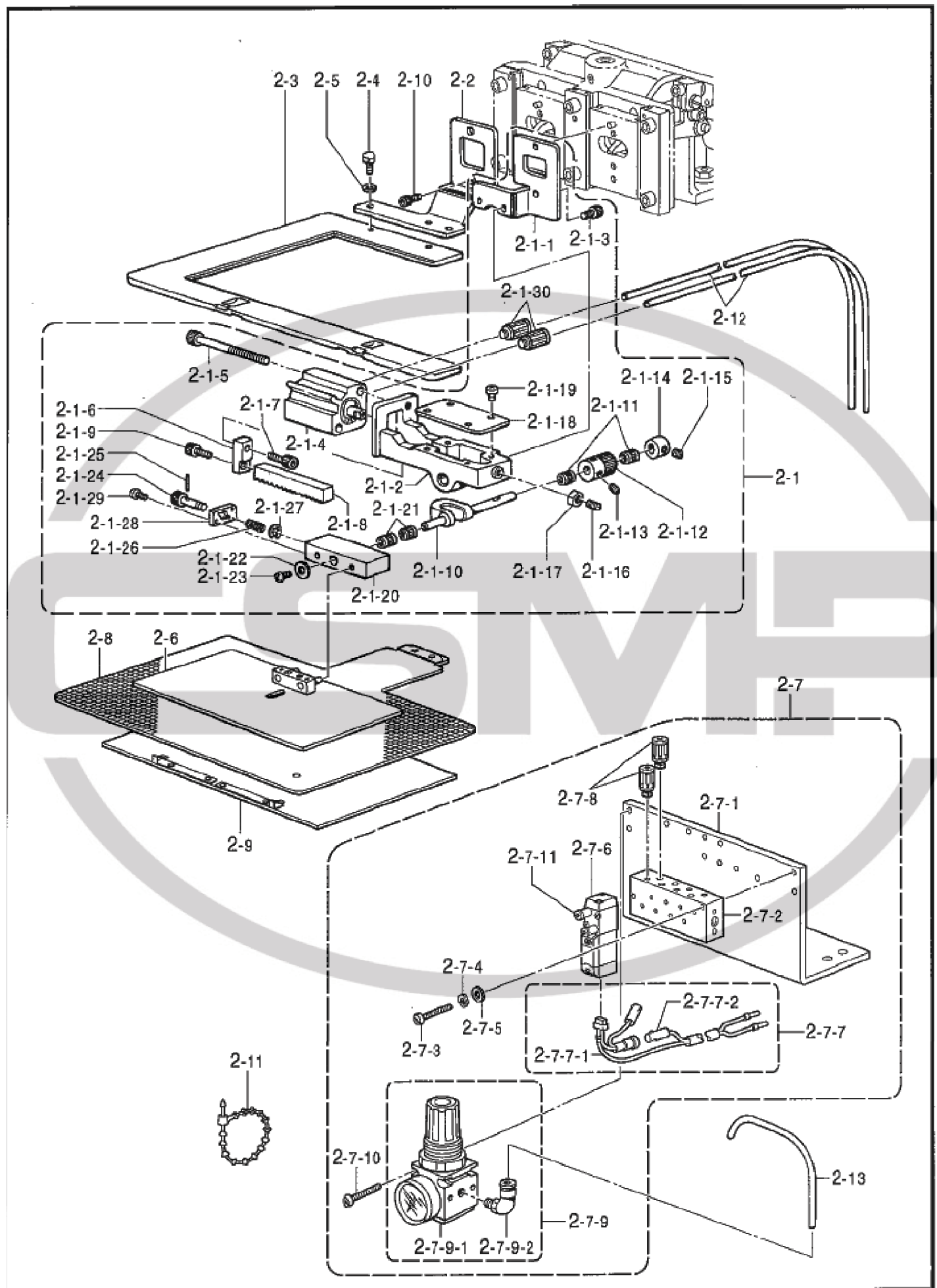

X2. 中押工反転装置関係 (オプション部品：縫製エリア250X150mm)

/ Inner clamping device (Option parts : Sewing area 250X150 mm)

REF.NO	CODE	QTY	品名	NAME OF PARTS	RM
2	S48511109	1	ハテンツクセットL	INNER CLAMPING DEVICE SET, L	
2-1	S21505109	1	オサエクシクミ	WORK CLAMP CRANK ASSY	
2-1-1	S21151001	1	カオサエアシ	WORK CLAMP FOOT, M	
2-1-2	S21152001	1	オサエクシホルダ	HOLDER, WORK CRANK	
2-1-3	018501036	2	アホ ^レ M5X10	BOLT, SOCKET M5X10	
2-1-4	S21156000	1	ハテンリシタ	REVERSE CYLINDER	
2-1-5	S24729000	2	CO2ホ ^レ M5X45	BOLT, CO2 M5X45	
2-1-6	S21157001	1	ハテンツクツキテ	REVERSE RACK JOINT	
2-1-7	018501436	2	アホ ^レ M5X14	BOLT, SOCKET M5X14	
2-1-8	S21158000	1	ハテンツク	REVERSE RACK	
2-1-9	018501236	1	アホ ^レ M5X12	BOLT, SOCKET M5X12	
2-1-10	S21159001	1	オサエクシク	WORK CLAMP CRANK	
2-1-11	S21153000	2	コシ ^ク 6	NEEDLE BEARING, 6	
2-1-12	S21160000	1	ハテンギヤ	REVERSE GEAR	
2-1-13	014710522	2	アトメシ ^ク 4.76ホ ^レ ミ	SET SCREW, SOCKET (CP) SM4.76	
2-1-14	155067001	1	ピン ^ク セットカ ^ラ	SET SCREW COLLAR, H-SHAFT	
2-1-15	014400432	1	アホ ^レ M4X4	SET SCREW, SOCKET (CP) M4X4	
2-1-16	115012002	1	トメシ ^ク 6.35	SET SCREW, SM6.35	
2-1-17	150554002	1	ナツ ^ク 6.35	NUT, SM6.35	
2-1-18	S21154001	1	ハテンツクオサエイ	CLAMP PLATE, REVERSE RACK	
2-1-19	062501006	4	ホ ^レ M5X10	SCREW, PAN M5X10	
2-1-20	S21162001	1	オサエホルダ	HOLDER, CLAMPER	
2-1-21	S21153000	2	コシ ^ク 6	NEEDLE BEARING, 6	
2-1-22	S21161001	1	スラスト ^ク カ ^ラ 3.6	WASHER, THRUST 3.6	
2-1-23	062670616	1	ホ ^レ M3.57-40X6	SCREW, PAN SM3.57-40X6	
2-1-24	S20284001	1	イキ ^ク ピン	POSITIONING PIN	
2-1-25	047140850	1	スプリング ^ク ピン 1.4X8	PIN, SPRING ROLL 1.4X8	
2-1-26	S20285001	1	イキ ^ク ピン ^ク ハ ^レ ネ	SPRING	
2-1-27	048030342	1	トメ ^ク E3	RETAINING RING, E3	
2-1-28	S21163001	1	サイド ^ク プレート	SIDE PLATE	
2-1-29	062300616	1	ホ ^レ M3X6	SCREW, PAN M3X6	
2-1-30	S18415101	2	ハーフユニオンQ4M5	HALF UNION :Q4M5	
2-2	S21167001	1	ソトオサエアシ	WORK CLAMP, U-EXTERNAL	
2-3	S21171001	1	ソトオサエ	WORK CLAMP, EXTERNAL	
2-4	153403002	2	ホ ^レ M4.37X7	BOLT, SM4.37X7	
2-5	025680232	2	ヒラサ ^ク カ ^ラ ネ ^ク ヲ ^ク 4.37	WASHER, PLAIN M 4.37	
2-6	S21507001	1	カオサエイタ ^ク B ^ク ミ	INNER CLAMP PLATE ASSY, B	
2-7	S49436109	1	ハテン ^ク ハ ^レ ム ^ク 4 ^ク ミ	VALVE ASSY, 4 ;IN-CLAMP	
2-7-1	S31570409	1	ハ ^レ ム ^ク トリツクイタ ^ク 4-5H	VALVE SETTING PLATE, 4-5H	
2-7-2	S18375101	1	エアマニホ ^ク M4	AIR MANIFOLD, 4	
2-7-3	062302505	2	ホ ^レ M3X25	SCREW, PAN M3X25	
2-7-4	028030242	2	ハ ^レ ネ ^ク カ ^ラ 2-3	WASHER, SPRING 2-3	
2-7-5	025030232	2	ヒラサ ^ク カ ^ラ ネ ^ク ヲ ^ク 3	WASHER, PLAIN M 3	
2-7-6	S49432001	1	ソレノイド ^ク ハ ^レ ム ^ク	SOLENOID VALVE	
2-7-7	S43696100	1	ハ ^レ ム ^ク ハ ^レ ネ ^ク X1 ^ク ミ	VALVE HARNESS ASSY, X1	
2-7-7-1	S44746100	1	ツイカ ^ク ハ ^レ ム ^ク ハ ^レ ネ ^ク	VALVE HARNESS	
2-7-7-2	S44750100	1	ツイカ ^ク ハ ^レ ム ^ク ハ ^レ ネ ^ク 24V	VALVE HARNESS, 24V	
2-7-8	S18415101	2	ハーフユニオンQ4M5	HALF UNION :Q4M5	
2-7-9	S45252000	1	レギュレ ^ク タ ^ク ミ	REGULATOR ASSY	
2-7-9-1	S45253000	1	レギュレ ^ク タ	REGULATOR	
2-7-9-2	S45254000	2	ツキ ^ク テ ^ク 3109-4-10	JOINT, 3109-4-10	
2-7-10	062404005	2	ホ ^レ M4X40	SCREW, PAN M4X40	
2-7-11	S03792001	2	エキシホ ^ク リ ^ク バ ^ク ン	EXHAUST THROTTLE VALVE	
2-8	S47612001	1	オクリイタ ^ク ラ ^ク ンカ	FEED PLATE BLANK, A T=1.0	
2-9	S21476001	1	OTオサエイタ ^ク ミ	OT-CASSETTE PLATE ASSY	
2-10	018501222	2	アホ ^レ M5X12	BOLT, SOCKET M5X12	
2-11	340400001	2	ビーズ ^ク バ ^ク ン	BEAD BAND	
2-12	S15031008	2	エアチューブ	AIR TUBE, 4X2.5 L=1900	
2-13	S20006000	1	ウレタンチューブ S	URETHANE TUBE, S	

" 補給用部品 / For supply parts "

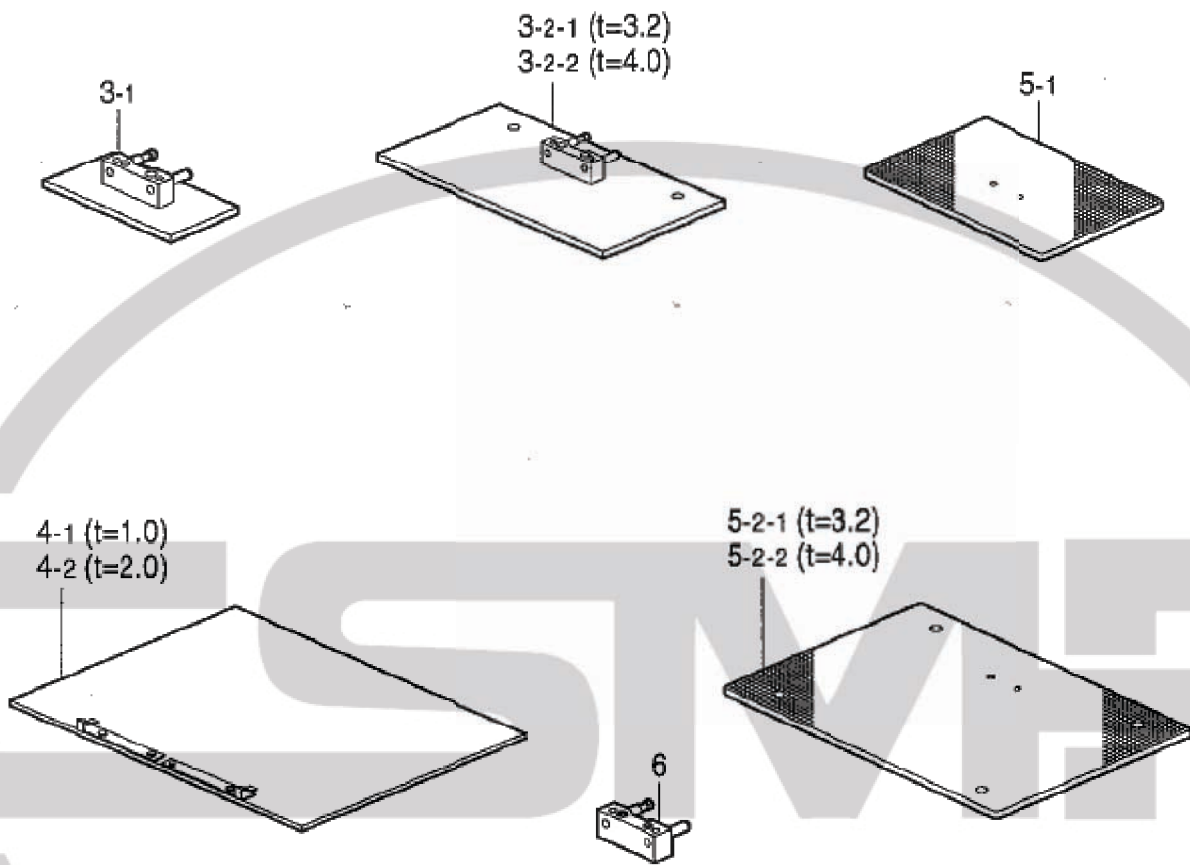

X3. 中押工反転装置関係 (オプション部品) / Inner clamping device (Option parts)

REF.NO	CODE	Q'TY	ヒンメイ	NAME OF PARTS	RM
			" 補給用部品" <縫製エリア100X60mm用>	"For supply parts" <For sewing area 100X60 mm>	
3-1	S21506001	1	ナオサイトA _{クミ} (t=3.2)	INNER CLAMP PLATE ASSY, A (t=3.2)	
			<縫製エリア250X150mm用>	<For sewing area 250X150 mm>	
3-2-1	S21507001	1	ナオサイトB _{クミ} (t=3.2)	INNER CLAMP PLATE ASSY, B (t=3.2)	
3-2-2	S21508001	1	ナオサイトC _{クミ} (t=4.0)	INNER CLAMP PLATE ASSY, C (t=4.0)	
4-1	S21476001	1	OTオサイト _{クミ} (t=1.0)	OT-CASSETTE PLATE ASSY (t=1.0)	
4-2	S21476002	1	OTオサイト _{クミ} (t=2.0)	OT-CASSETTE PLATE ASSY (t=2.0)	
			<縫製エリア100X60mm用>	<For sewing area 100X60 mm>	
5-1	S21168001	1	ナオサイトA (t=3.2)	INNER CLAMP PLATE, A (t=3.2)	
			<縫製エリア250X150mm用>	<For sewing area 250X150 mm>	
5-2-1	S21169001	1	ナオサイトB (t=3.2)	INNER CLAMP PLATE, B (t=3.2)	
5-2-2	S21170001	1	ナオサイトC (t=4.0)	INNER CLAMP PLATE, C (t=4.0)	
6	S31134001	1	シクホダ _{クミ}	HOLDER ASSY	

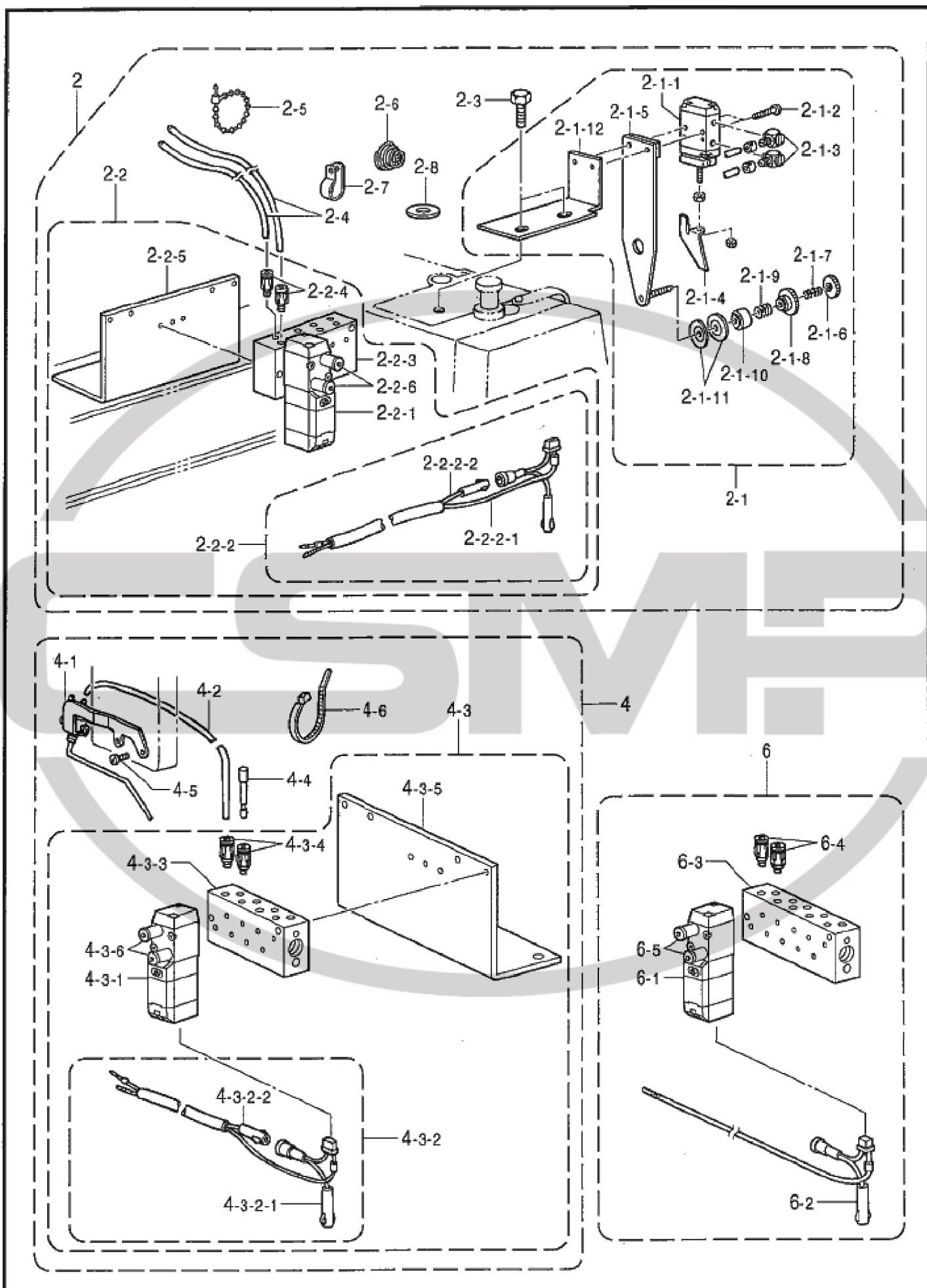

AA1. 補助装置関係 (オプション部品) / Auxiliary device (Option parts)

REF.NO	CODE	QTY	品名	NAME OF PARTS	RM
			<2段系調子装置>	<2-step tension device>	
2	S48501201	1	2段階調子セット	2-STEP THREAD TENSION SET, 2	
2-1	S43838101	1	2段階テンション	2-STEP THREAD TENSION ASSY	
2-1-1	S34706000	1	エアシリンダ 10X10	AIR CYLINDER, 10X10	
2-1-2	018302032	2	アネルト 3X20	SCREW 3X20	
2-1-3	S12150000	2	ホースエルボ M-5HL-4	TUBE ELBOW, M-5HL-4	
2-1-4	S34533001	1	サブクランプ	COUNTERSINK CLAW	
2-1-5	S34534101	1	サブテンションブラケット	SUB TENSION BRACKET ASSY	
2-1-6	155510001	1	テンションナット	TENSION NUT	
2-1-7	146060000	1	バネ	SPRING	
2-1-8	146059001	1	プレテンションナット	PRE-TENSION NUT	
2-1-9	146058001	1	プレテンションバネ	PRE-TENSION SPRING	
2-1-10	146206009	1	ディスクプレス Tガイド	DISC PRESSER, T-GUIDE	
2-1-11	144504001	2	ガイド付きディスク	THREAD GUIDEDISC	
2-1-12	S34536101	1	シリンダ取り付け台	SETTING BRACKET, CYLINDER	
2-2	S49437105	1	ソレノイドバルブ OP4	SOLENOID VALVE ASSY, OP4	
2-2-1	S49432001	1	ソレノイドバルブ	SOLENOID VALVE	
2-2-2	S43696100	1	バルブハーネス X1	VALVE HARNESS ASSY, X1	
2-2-2-1	S44746100	1	バルブハーネス	VALVE HARNESS	
2-2-2-2	S44750100	1	バルブハーネス 24V	VALVE HARNESS, 24V	
2-2-3	S18375101	1	エアマニホールド 4	AIR MANIFOLD, 4	
2-2-4	S18415101	2	ハーフユニオン Q4M5	HALF UNION :Q4M5	
2-2-5	S31554109	1	バルブトリックプレート 4-5	SETTING PLATE, 4-5:VALVE	
2-2-6	S03792001	2	エキゾーストバルブ	EXHAUST THROTTLE VALVE	
2-3	017821813	2	ボルト 7.94X18	BOLT, SM7.94X18	
2-4	S15031008	2	エアチューブ	AIR TUBE, 4X2.5 L=1900	
2-5	340400001	5	ビーズバンド	BEAD BAND	
2-6	104525001	1	テンションバネ	TENSION SPRING	
2-7	149287000	3	コードホルダー 7N	CORD HOLDER, 7N	
2-8	S48140002	1	ワッシャー	WASHER	
			<ニードルクーラー装置>	<Needle cooler set>	
4	S48503109	1	ニードルクーラーセット	NEEDLE COOLER SET	
4-1	S18027101	1	ニードルブLOWER	NEEDLE BLOWER	
4-2	S15031008	1	エアチューブ	AIR TUBE, 4X2.5 L=1900	
4-3	S49437008	1	ソレノイドバルブ OP4	SOLENOID VALVE ASSY, OP4	
4-3-1	S49432001	1	ソレノイドバルブ	SOLENOID VALVE	
4-3-2	S43696100	1	バルブハーネス X1	VALVE HARNESS ASSY, X1	
4-3-2-1	S44746100	1	バルブハーネス	VALVE HARNESS	
4-3-2-2	S44750100	1	バルブハーネス 24V	VALVE HARNESS, 24V	
4-3-3	S18375101	1	エアマニホールド 4	AIR MANIFOLD, 4	
4-3-4	S18415101	2	ハーフユニオン Q4M5	HALF UNION :Q4M5	
4-3-5	S31554109	1	バルブトリックプレート 4-5	SETTING PLATE, 4-5:VALVE	
4-3-6	S03792001	2	エキゾーストバルブ	EXHAUST THROTTLE VALVE	
4-4	S04897000	1	プラグ 4	PLUG, 4	
4-5	062670812	2	ネジ 3.57-40X8	SCREW, PAN SM3.57-40X8	
4-6	228475000	3	タイイングバンド 1.9X80	TYING BAND 1.9X80	
			<追加バルブセット>	<Addition valve set>	
6	S54797001	1	ソレノイドバルブ OP5	SOLENOID VALVE ASSY, OP5	
6-1	S49432001	1	ソレノイドバルブ	SOLENOID VALVE	
6-2	S44746100	1	バルブハーネス	VALVE HARNESS	
6-3	S33956000	1	エアマニホールド 5	AIR MANIFOLD, 5	
6-4	S18415101	2	ハーフユニオン Q4M5	HALF UNION :Q4M5	
6-5	S03792001	2	エキゾーストバルブ	EXHAUST THROTTLE VALVE	

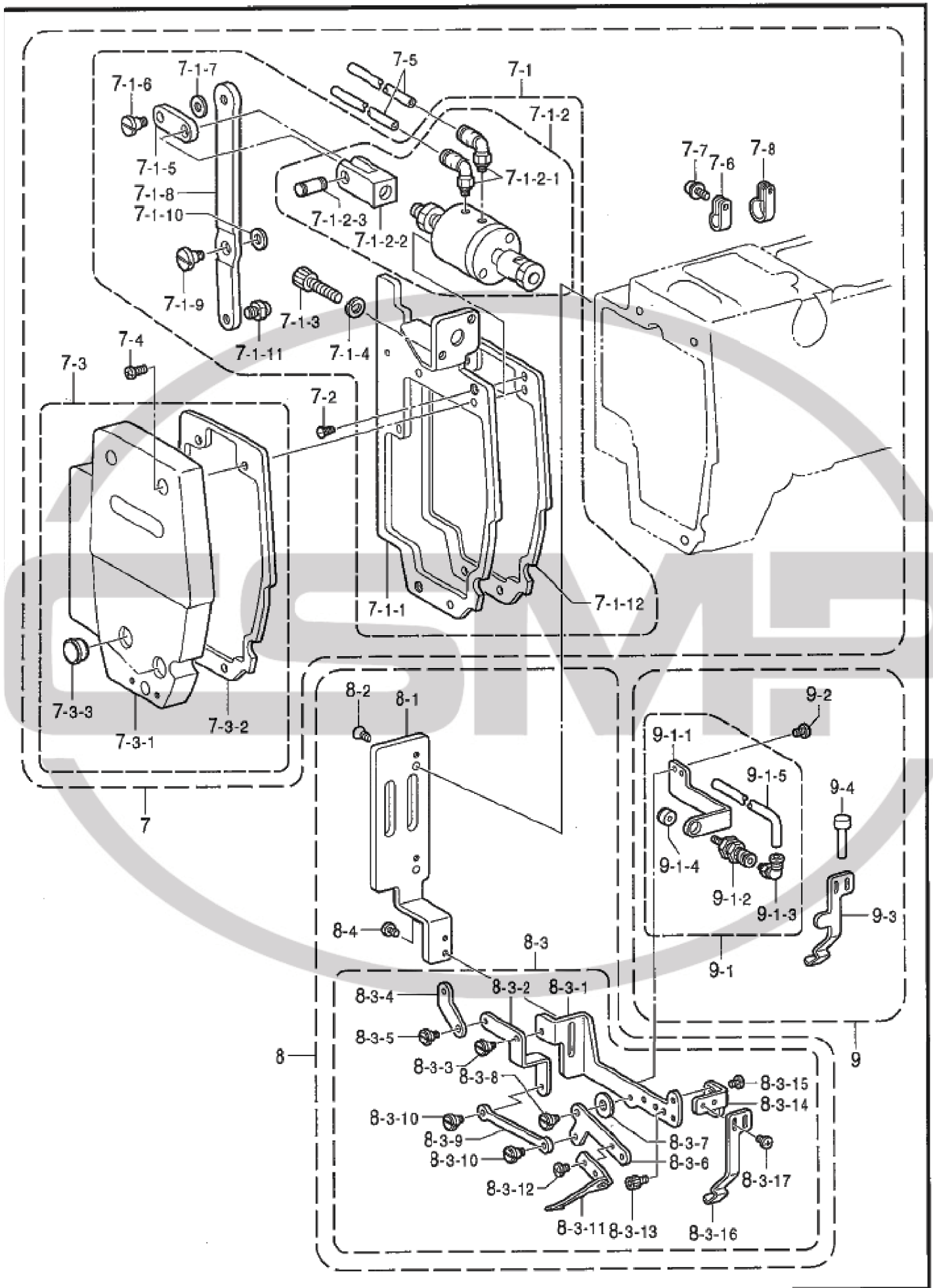

AA2. 補助装置関係 (オプション部品) / Auxiliary device (Option parts)

REF.NO	CODE	QTY	品名	NAME OF PARTS	RM
			<2段階工足装置>	<2-step work clamp device>	
7	S54786001	1	2段階工足装置341	2-STEP WORK CLAMP DEVICE, 341	
7-1	S54787001	1	2段階工足装置341	2-STEP WORK CLAMP ASSY, 341	
7-1-1	S54788001	1	スペーサ-341	SPACER, 341-F	
7-1-2	S51473000	1	シリンダ-25-10	CYLINDER ASSY, 25-10	
7-1-2-1	S11426000	2	エルボユニオン4M5	ELBOW UNION, 4M5	
7-1-2-2	S41523000	1	クヌケジョイント	KNUKLE JOINT	
7-1-2-3	S41524000	1	ピン	PIN	
7-1-3	018062036	2	ボルトソケットM6X20	BOLT, SOCKET M6X20	
7-1-4	028060246	2	ワッシャースプリング2-6	WASHER, SPRING 2-6	
7-1-5	S51476001	1	リンク	LINK	
7-1-6	150451001	1	タネネジ6.35	SHOULDER SCREW, SM6.35	
7-1-7	153138001	1	ワッシャー	WASHER, PLAIN 6.5	
7-1-8	S51477001	1	レバー	LEVER	
7-1-9	S19817001	1	タネネジ5.95	SHOULDER SCREW, SM5.95	
7-1-10	153138001	1	ワッシャー	WASHER, PLAIN 6.5	
7-1-11	S51478001	1	ローラシャフト	ROLLER SHAFT, W/SCREW SM6.35	
7-1-12	S25155100	1	パッキング	PACKING, F	
7-2	100032004	2	ネジ4.37	SCREW, FLAT SM4.37-40X8	
7-3	S54790009	1	341フェイスプレート	FACE PLATE ASSY, 2SF ;341	
7-3-1	S54791009	1	341フェイスプレート	FACE PLATE, 2SF ;341	
7-3-2	S54792000	1	341フェイスプレート	PACKING, FACE PLATE ;2SF	
7-3-3	117934001	2	ゴムキャップ13.5	RUBBER CAP, 13.5	
7-4	062711412	3	ネジM4.76-32X14	SCREW, PAN SM4.76-32X14	
7-5	S15031010	2	エアチューブ	AIR TUBE, 4X2.5 L=2100	
7-6	S25664000	1	コードホルダ6N	CORD HOLDER, 6N	
7-7	0A5400806	1	ネジM4X8DB	SCREW, PAN (S/P WASHER) M4X8	
7-8	S25567000	4	コードホルダ8N	CORD HOLDER, 8N	
			<糸つかみセット>	<U-thread nipper device>	
8	S53154001	1	糸つかみ装置	U-THREAD NIPPER DEVICE	
8-1	S53071001	1	ソレノイドベースプレート	SOLENOID BASE PLATE	
8-2	100032004	2	ネジ4.37	SCREW, FLAT SM4.37-40X8	
8-3	S53070001	1	糸つかみ装置300E	THREAD NIPPER ASSY, 300E	
8-3-1	S53072001	1	糸つかみ装置	FULCRUM PLATE, TR-NIPPER	
8-3-2	S53073001	1	糸つかみ装置	CRANK, TR-NIPPER	
8-3-3	S46842001	1	タネネジ4	SHOULDER SCREW, M4	
8-3-4	S53074001	1	ソレノイド接続ロッド	SOLENOID CONNECTING ROD	
8-3-5	113730001	1	タネネジ4.37	SHOULDER SCREW, SM4.37	
8-3-6	S53075001	1	糸つかみ装置ブラケット	THREAD NIPPER BRACKET	
8-3-7	S19543001	1	ワッシャー	WASHER	
8-3-8	S46842001	1	タネネジ4	SHOULDER SCREW, M4	
8-3-9	S53076001	1	糸つかみ装置	THREAD NIPPER CONNECTING PLATE	
8-3-10	113730001	2	タネネジ4.37	SHOULDER SCREW, SM4.37	
8-3-11	S53077001	1	糸つかみ装置	THREAD NIPPER	
8-3-12	060670512	2	ネジSM3.57-40X5	SCREW, BIND SM3.57-40X5	
8-3-13	018680522	1	ボルトソケット4.37X5	BOLT, SOCKET SM4.37X5	
8-3-14	S53078001	1	糸つかみ装置	THREAD PRESSER BRACKET	
8-3-15	060670512	2	ネジSM3.57-40X5	SCREW, BIND SM3.57-40X5	
8-3-16	S53079001	1	糸つかみ装置	THREAD PRESSER	
8-3-17	060670512	2	ネジSM3.57-40X5	SCREW, BIND SM3.57-40X5	
8-4	060680512	2	ネジSM4.37-40X5	SCREW, BIND SM4.37-40X5	

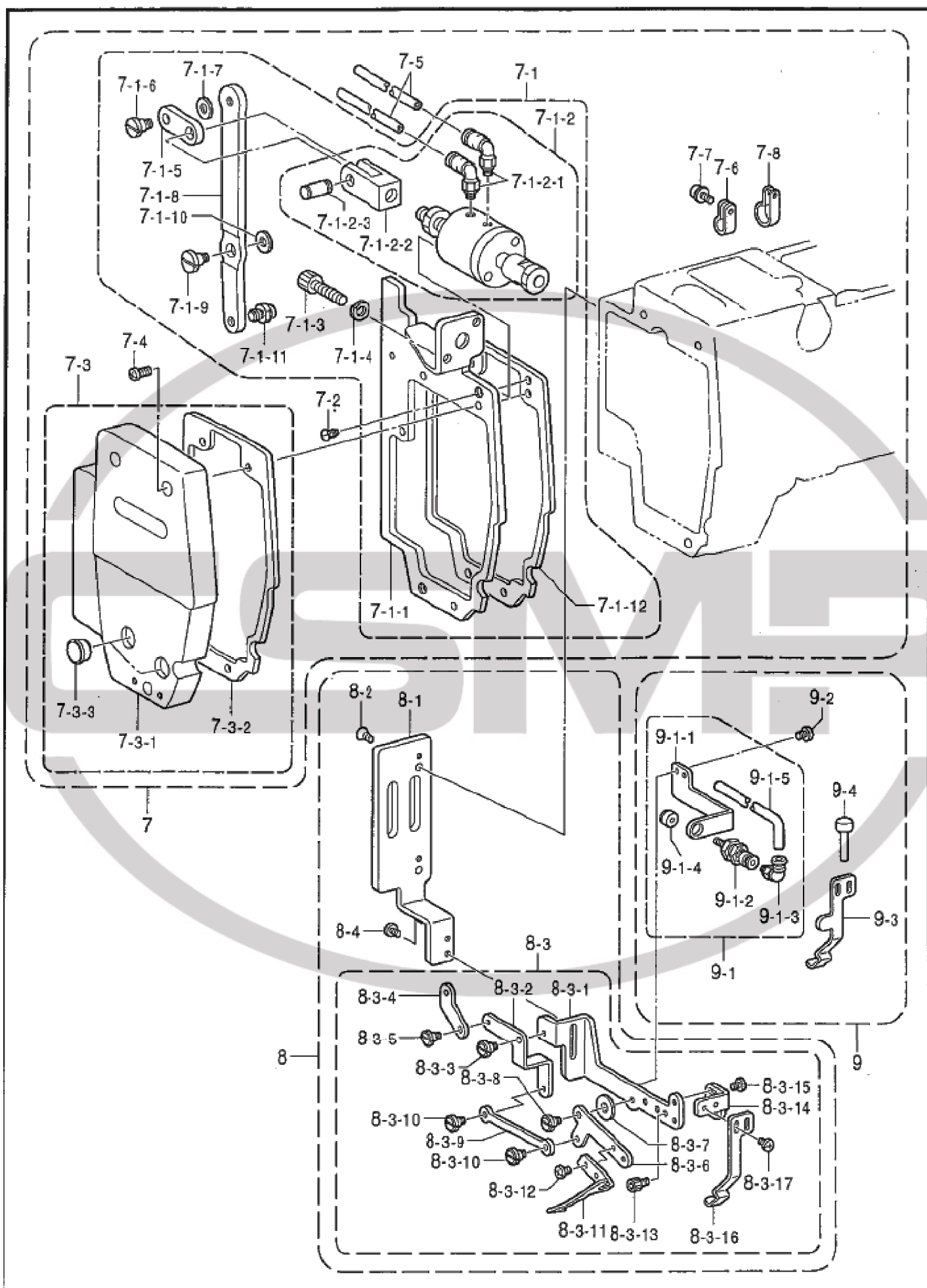

AA2. 補助装置関係 (オプション部品) / Auxiliary device (Option parts)

REF.NO	CODE	QTY	品名	NAME OF PARTS	RM
			<糸放しシリンダセット>	<Thread release cylinder set>	
9	S53155001	1	1 糸放しシリンダセット	THREAD RELEASE CYLINDER SET	
9-1	S53080001	1	1 糸放しシリンダアッシー	THREAD RELEASE CYLINDER ASSY	
9-1-1	S53081001	1	1 シリンダブラケット	CYLINDER BRACKET	
9-1-2	S16996000	1	1 シリンダ 6X5	CYLINDER, 6X5	
9-1-3	S18382000	1	1 エルボ M5	ELBOW, M5	
9-1-4	S16997100	1	1 ナイロワザ	NEEDLE THREAD PRESSER	
9-1-5	S15031008	1	1 エアチューブ	AIR TUBE, 4X2.5 L=1900	
9-2	060680512	2	2 M4.37-40X5	SCREW, BIND SM4.37-40X5	
9-3	S53082001	1	1 ナイロワザ	TR-PRESSER, S	
9-4	S04897000	1	1 プラグ 4	PLUG, 4	

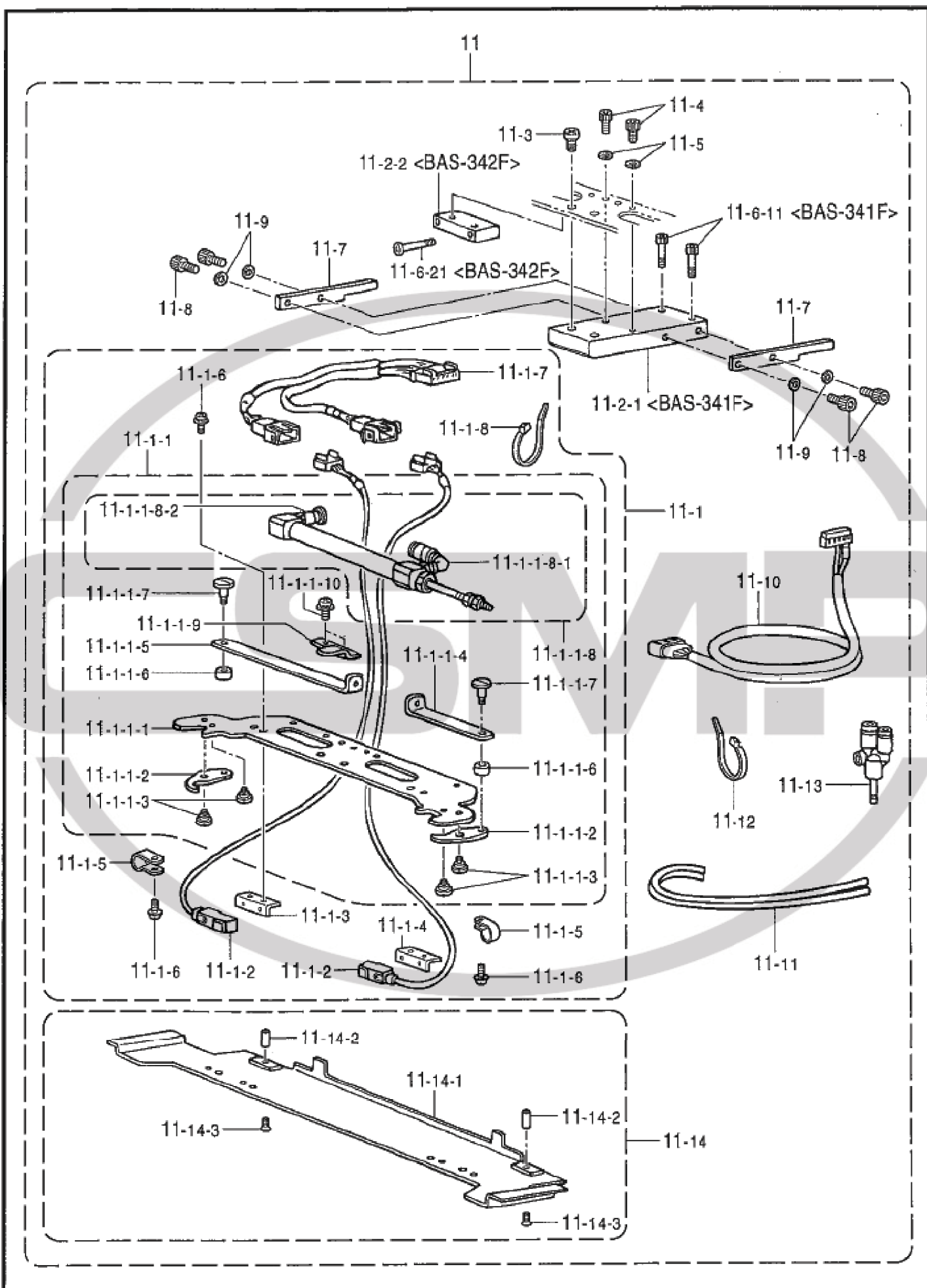

AA3. 補助装置関係 (オプション部品) / Auxiliary device (Option parts)

REF.NO	CODE	QTY	ヒンメイ	NAME OF PARTS	RM
			<オートイジェクター>	<Automatic ejector>	
11	S51429101	1	オートイジェクタセット	AUTOMATIC EJECTOR SET	
11-1	S37761101	1	オートイジェクタH.S	AUTOMATIC EJECTOR ASSY, H.S	
11-1-1	S37762101	1	オートイジェクタ本体	AUTOMATIC EJECTOR BODY ASSY	
11-1-1-1	S37763101	1	オートイジェクタ本体1C	AUTOMATIC EJECTOR BODY, 1C	
11-1-1-2	S37764001	2	AEフック	HOOK, AE	
11-1-1-3	159269001	4	シャトルリンクタンネジ	SHOULDER SCREW, SM4.37	
11-1-1-4	S37765001	1	フック駆動レバー70	HOOK DRIVING LEVER, 70	
11-1-1-5	S37766001	1	フック駆動レバー180	HOOK DRIVING LEVER, 180	
11-1-1-6	S02301001	2	ローラW-クランプリフター	ROLLER, W-CLAMP LIFTER	
11-1-1-7	141499001	2	タンネジ4.76	SHOULDER SCREW, SM4.76	
11-1-1-8	S37767000	1	シリンダークミ10-45	CYLINDER ASSY, 10-45	
11-1-1-8-1	S11426000	1	エルボユニオン4M5	ELBOW UNION, 4M5	
11-1-1-8-2	S04905000	1	ハーフユニオン	HALF UNION	
11-1-1-9	S37768001	1	フック駆動レバーホルダ	HOLDER PLATE	
11-1-1-10	052400806	2	ナットM4X8	SCREW, PAN (S/P WASHER) M4X8	
11-1-2	S20083000	2	ホールセンサ	HOLE SENSOR	
11-1-3	S37769001	1	センサブラケットL	SENSOR BRACKET, L	
11-1-4	S37770001	1	センサブラケットR	SENSOR BRACKET, R	
11-1-5	625010000	2	ナイロンクランプNK-2N	NYLON CLAMP NK-2N	
11-1-6	533527001	6	ナットM3X8DB	SCREW, PAN (S/P WASHER) M3X8	
11-1-7	S37780000	1	AEセンサハーネスA	AE-SENSOR HARNESS, A	
11-1-8	S04557000	7	バンドPLT1M	BAND, PLT1M	
			<BAS-341F用>	<For BAS-341F>	
11-2-1	S37775001	1	AEリセットプレート341A	AE-SETTING PLATE, 341A	
			<BAS-342F用>	<For BAS-342F>	
11-2-2	S37771001	1	AEリセットプレート342A	AE-SETTING PLATE, 342A	
11-3	S10352101	2	クリイシメネジ	SCREW, ROUND W/SOCKET SM4.37	
11-4	018401022	2	ソケットボルトM4X10	BOLT, SOCKET M4X10	
11-5	028040242	2	ワッシャースプリング2-4	WASHER, SPRING 2-4	
			<BAS-341F用>	<For BAS-341F>	
11-6-1	150382001	2	ソケットボルトM4.37X18	BOLT, SOCKET SM4.37X18	
			<BAS-342F用>	<For BAS-342F>	
11-6-2	S31808001	2	ナットM4.37-40X25	SCREW, PAN SM4.37-40X25	
11-7	S37776101	2	ガイドプレート	GUIDE PLATE	
11-8	018501222	4	ソケットボルトM5X12	BOLT, SOCKET M5X12	
11-9	028050242	4	ワッシャースプリング2-5	WASHER, SPRING 2-5	
11-10	S51426000	1	AEセンサハーネス	SENSOR HARNESS, AE	
11-11	S15031008	2	エアチューブ	AIR TUBE, 4X2.5 L=1900	
11-12	S04557000	5	バンドPLT1M	BAND, PLT1M	
11-13	S08178000	2	ブランチUY-4	BRANCH, UY-4	
11-14	S37772101	2	AEカセットプレート342	AE-CASSETTE PLATE ASSY, 342	
11-14-1	S37773001	2	AEカセットプレート342	AE-CASSETTE PLATE, 342	
11-14-2	S37774001	4	AEカセットピン	PIN	
11-14-3	S25310101	4	ネジM4	SCREW, FLAT M4	

< A=1 : 中厚物用 / For Medium materials >

< A=2 : 厚物用 / For Heavy materials >

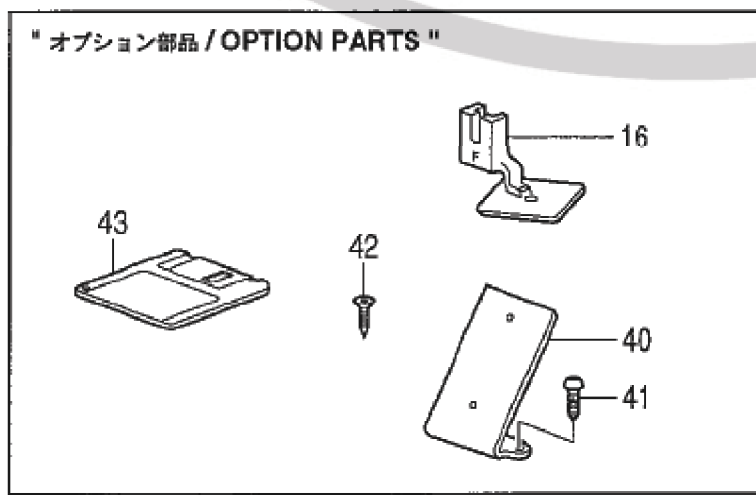
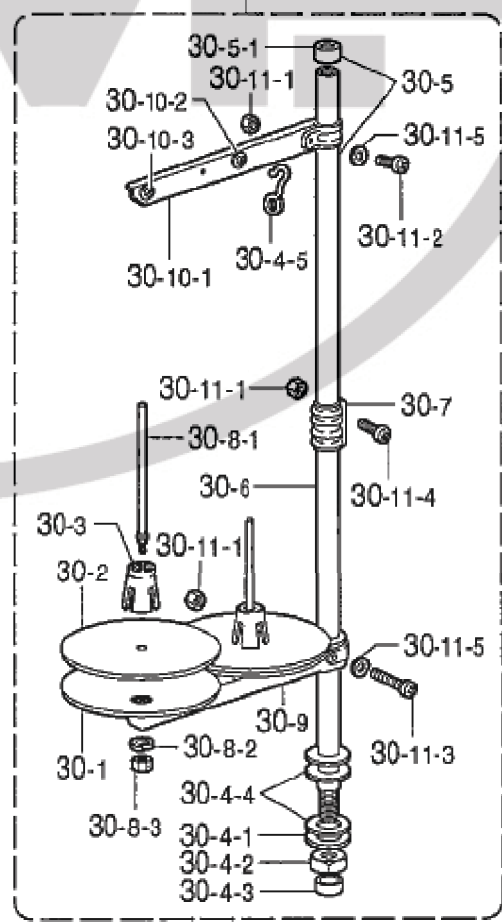
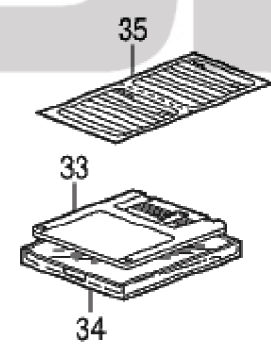
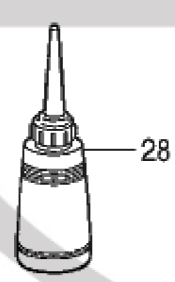
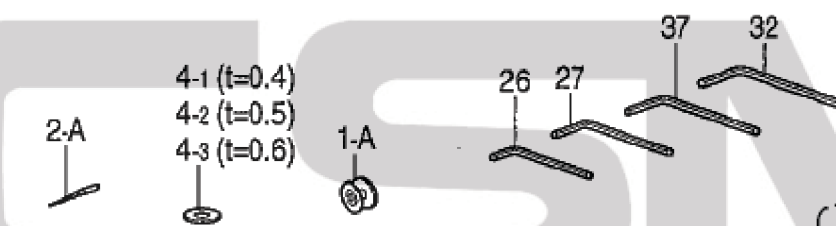
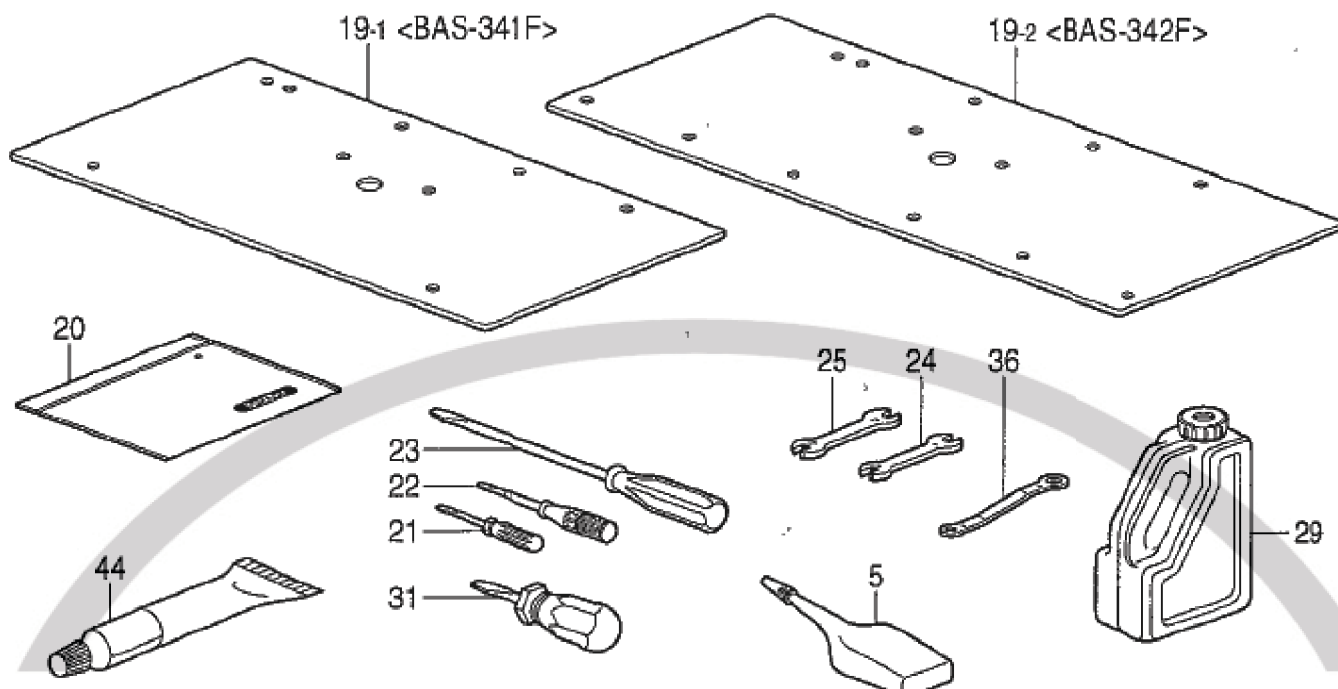

Z. 付属品関係 / Accessories

REF.NO	CODE	QTY	ヒンメイ	NAME OF PARTS	RM
1-1	S15665001	3	<中厚物用> ボビンLA	<For medium materials> BOBBIN, LA	
1-2	S15666001	3	<厚物用> ボビンLB	<For heavy materials> BOBBIN, LB	
2-1	SA1752016	1	<中厚物用> 107415ハリ4コイリクミ (DPX5#16)	<For medium materials> NEEDLE 4PIECE ASSY, 107415 (DPX5#16)	
2-2	SA1645021	1	<厚物用> 145646ハリ4コイリクミ (DPX17#21)	<For heavy materials> NEEDLE 4 PIECE ASSY, 145646 (DPX17#21)	
4-1	S10208001	1	トウカンゾウ (t=0.4)	MOVABLE KNIFE SPACER (t=0.4)	
4-2	S10208002	1	トウカンゾウ (t=0.5)	MOVABLE KNIFE SPACER (t=0.5)	
4-3	S10208003	1	トウカンゾウ (t=0.6)	MOVABLE KNIFE SPACER (t=0.6)	
5	S06706001	1	シリコンオイル	SILICONE OIL	
9	S08030000	1	ヒューズ5AFB	FUSE, 5A :FB	
10	153242000	1	ヒューズ6A	FUSE, 6A	
16	157237001	1	"オプション部品" プレスアソフ	"OPTION PARTS" PRESSER FOOT, F	
19-1	S18039000	2	<BAS-341F用> ハリ補助シート	<For BAS-341F> AUXILIARY PLATE SHEET	
19-2	S47318000	2	<BAS-342F用> ハリ補助シート	<For BAS-342F> AUXILIARY SHEET, NEEDLE PLATE	
20	122991001	1	アクセサリーバッグ	ACCESSORY BAG	
21	142443001	1	ネジマシ1.9X52	SCREW-DRIVER, 1.9X52	
22	118837001	1	ネジマシ3.4X70	SCREW-DRIVER, 3.4X70	
23	101572101	1	ネジマシ5.5X190	SCREW-DRIVER, 5.5X190	
24	100887001	1	スパナ8X9	WRENCH, 8X9	
25	107780001	1	スパナ10X12	WRENCH, 10X12	
26	142721001	1	六角ボウスナナ3	HEXAGONAL WRENCH, 3	
27	118064001	1	六角ボウスナナ4	HEXAGONAL WRENCH, 4	
28	114483002	1	ホリオリークミ	OILER ASSY	
29	S55663001	1	オイルタンク	OIL TANK ASSY	
30	S02763402	1	トタテイグミ2DR	COTTON STAND ASSY, 2DR	
30-1	S51283001	2	ウチサテ	SPOOL STAND BASE	
30-2	150182000	2	マット	SPOOL MAT	
30-3	S51282001	2	クッション	SPOOL CUSHION	
30-4	S02777001	1	パイプDネジセット	PIPE (D) SCREW SET, B	
30-4-1	150206002	1	ワッシャー16	WASHER, PLAIN 16	
30-4-2	S38648001	1	ナットU5/8	NUT, U5/8-28	
30-4-3	150174000	1	コラムキャップ	COLUMN CAP	
30-4-4	S01005000	2	ゴムワッシャー	RUBBER WASHER	
30-4-5	S02747101	1	スプリング	SPRING	
30-5	S40640001	1	コラムパイプDキャップ	COLUMN PIPE W/CAP	
30-5-1	150174000	1	コラムキャップ	COLUMN CAP	
30-6	156112003	1	コラムパイプD	COLUMN PIPE, D	
30-7	150173003	1	コラムジョイント	COLUMN JOINT	
30-8	S21798001	2	パイプDネジセット	SPOOL & SCREW SET	
30-8-1	150179002	2	パイプシャフト	SPOOL SHAFT, B	
30-8-2	028050246	2	ワッシャースプリング2-5	WASHER, SPRING 2-5	
30-8-3	021500106	2	ナット1M5	NUT, 1 M5	
30-9	S02778002	1	スプールホルダー-2	SPOOL HOLDER, 2	
30-10	S02786002	1	スレッドハンガー-クミ2	THREAD HANGER ASSY, 2	

151-V41-910

付属品の明細は変更することがあります。

The details of included accessories are subject to change.

< A=1 : 中厚物用 / For Medium materials >

< A=2 : 厚物用 / For Heavy materials >

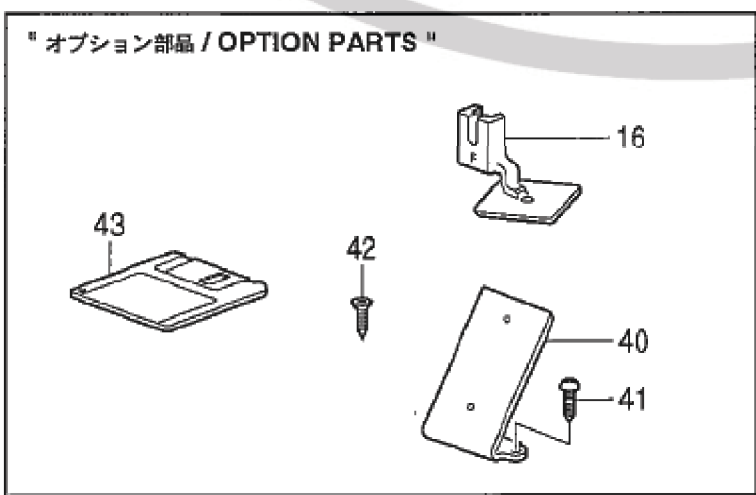
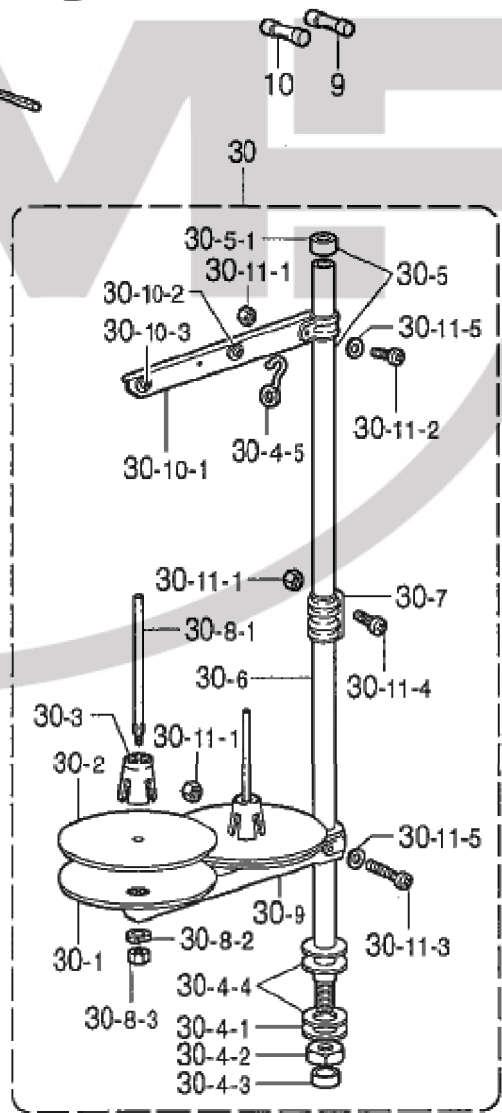
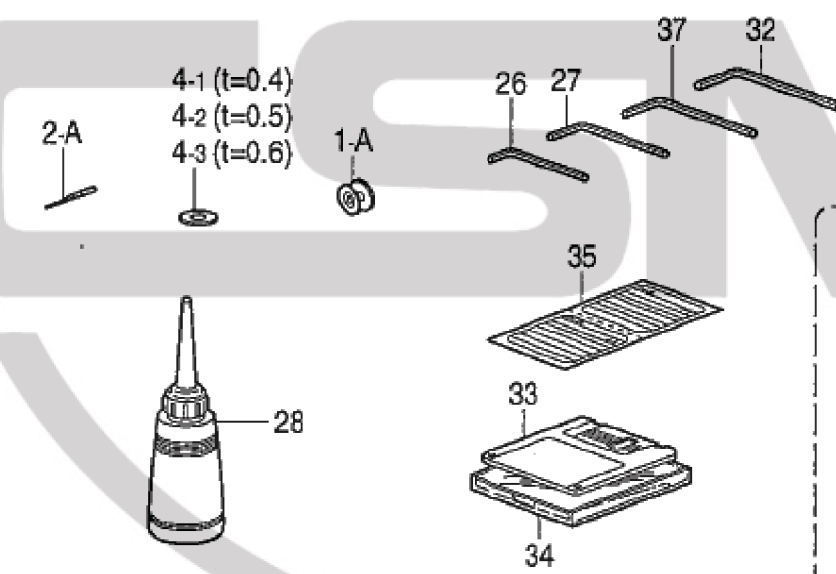
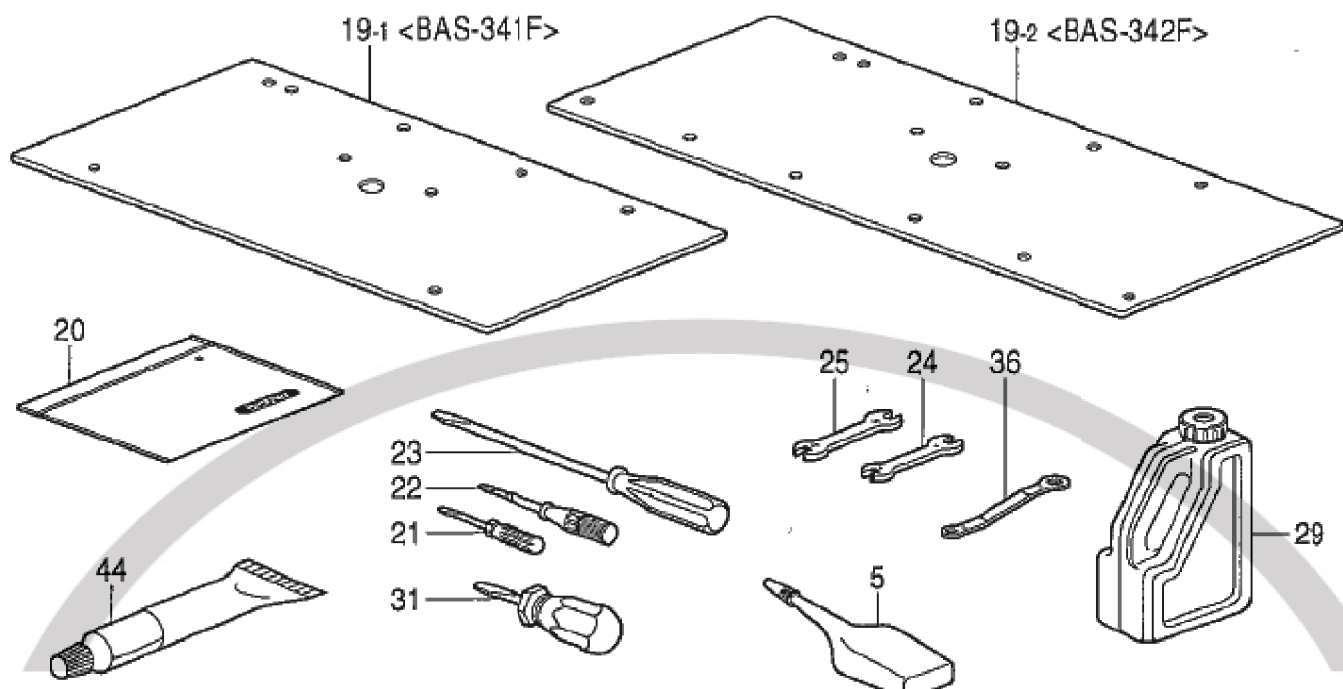

Z. 付属品関係 / Accessories

REF.NO	CODE	QTY	ヒンメイ	NAME OF PARTS	RM
30-10-1	S02787002	1	スレッドハンガー-2	THREAD HANGER, 2	
30-10-2	150183000	2	トカハンガー-タイ	THREAD HANGER BASE	
30-10-3	142990001	2	スレッドブッシュ	THREAD BUSH	
30-11	S40641001	1	スプールシャフト&ネジセットA	SPOOL SHAFT & SCREW SET, A	
30-11-1	021500106	4	1.5mmナット	NUT, 1 M5	
30-11-2	062501406	1	ネジ M5X14	SCREW, PAN M5X14	
30-11-3	S59931001	1	ネジ M5X32	SCREW, PAN M5X32	
30-11-4	062501406	2	ネジ M5X14	SCREW, PAN M5X14	
30-11-5	026050136	2	ワッシャー 5	WASHER, PLAIN S 5	
31	S11243001	1	スタビライザー	SCREW DRIVER, STUBBIES	
32	115157001	1	六角レンチ M6	HEXAGONAL WRENCH, 6	
33	S43273000	1	3.5mmメディア 2HD	3.5 MEDIA, 2HD	
34	S09989000	1	フロッピーケース	FLOPPY CASE	
35	S42658000	1	3.5インチラベル	INDEX LABEL, 3.5FD	
36	105343001	1	ダブルレンチ 8X9	DOUBLE WRENCH, 8X9	
37	150335001	1	六角レンチ M5	HEXAGONAL WRENCH, 5	
			" オプション部品 "	"OPTION PARTS"	
40	S42890001	1	プログラマーサポート	PROGRAMMER SUPPORT	
41	032422003	2	丸頭ネジ M4.1X20	WOOD SCREW, ROUND M4.1X20	
42	0B1351606	2	平頭ネジ M3.5X16	WOOD SCREW, FLAT M3.5X16	
43	S50001000	1	クリーニングディスク	CLEANING DISC	
44	S09021100	1	グリス	GREASE	



151-V41-910

付属品の明細は変更することがあります。

The details of included accessories are subject to change.

Ga1 . ゲージ部品一覧表 / Gauge parts List

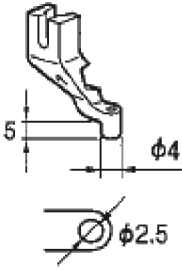
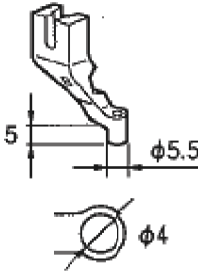
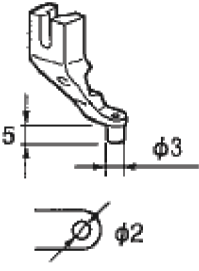
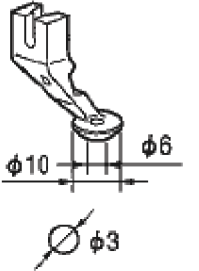
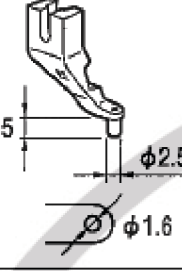
押工足 / Presser foot

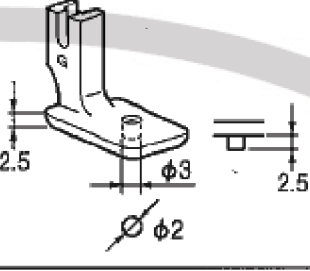
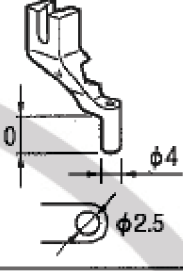
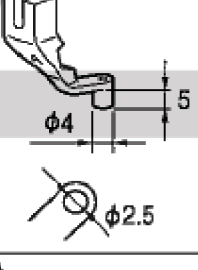
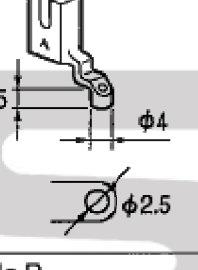
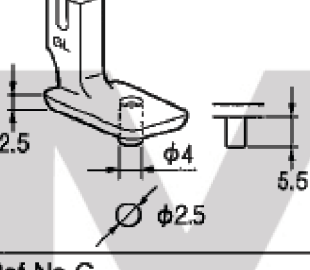
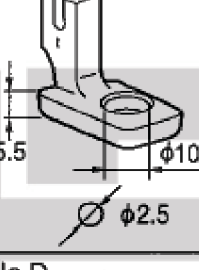
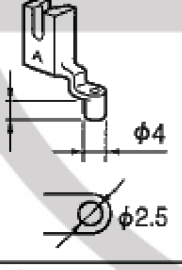
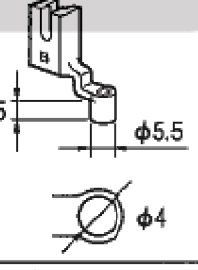
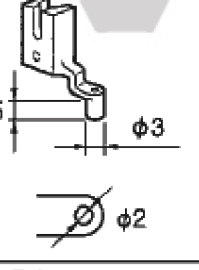
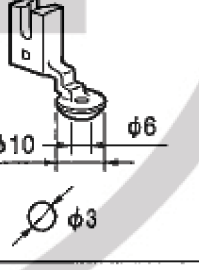
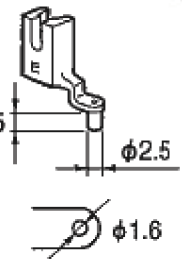
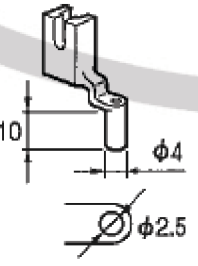
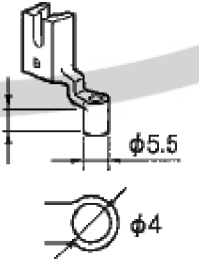
Ref.No.A *	Ref.No.B	Ref.No.C	Ref.No.D
			
Ref.No.E	Ref.No.F	Ref.No.G	Ref.No.J
			
Ref.No.XA	Ref.No.A-CUT	Ref.No.GL	Ref.No.I
			
Ref.No.A	Ref.No.B	Ref.No.C	Ref.No.D
			
Ref.No.E	Ref.No.J	Ref.No.B-L	
			

* 印の部品は、標準部品です。

The * symbol is for Standard parts.

Ga1. ゲージ部品一覧表 / Gauge parts List

REF.NO	CODE	QTY	ヒンメイ	NAME OF PARTS	RM
A	S42843001	1	押印A	PRESSER FOOT, A	*
			"オプション部品"	"OPTION PARTS"	
B	S42844001	1	押印B	PRESSER FOOT, B	
C	S42845001	1	押印C	PRESSER FOOT, C	
D	S42846001	1	押印D	PRESSER FOOT, D	
E	S42847001	1	押印E	PRESSER FOOT, E	
F	157237001	1	押印F	PRESSER FOOT, F	
G	158592001	1	押印G	PRESSER FOOT, G	
J	S42848001	1	押印J	PRESSER FOOT, J	
XA	S42849101	1	押印XA	PRESSER FOOT, XA	
A-CUT	S40214001	1	押印A-CUT	PRESSER FOOT, A-CUT	
GL	S20864001	1	押印GL	PRESSER FOOT, GL	
I	S04887001	1	押印I	PRESSER FOOT, I	
A	152283101	1	押印A	PRESSER FOOT, A	
B	152636101	1	押印B	PRESSER FOOT, B	
C	152637001	1	押印C	PRESSER FOOT, C	
D	154069001	1	押印D	PRESSER FOOT, D	
E	154089001	1	押印E	PRESSER FOOT, E	
J	S13815001	1	押印J	PRESSER FOOT, J	
B-L	S49448001	1	押印B-L	PRESSER FOOT, B-L	

151-V41

*印の部品は、標準部品です。

The * symbol is for standard parts.

針穴板 / Needle hole plate

Ref.No.A	Ref.No.D	Ref.No.E *	Ref.No.ED	Ref.No.F *
Ref.No.FD	Ref.No.H	Ref.No.L	Ref.No.M	Ref.No.3

* 印の部品は、標準部品です。

The * symbol is for Standard parts.

CSMP







Ga2. ゲージ部品一覧表 / Gauge parts List

REF.NO	CODE	Q'TY	ヒンメイ	NAME OF PARTS	RM
			" オプション部品"	"OPTION PARTS"	
A	S10211001	1	ルリアイタA (φ1.6)	NEEDLE HOLE PLATE, A (φ1.6)	
D	S29997001	1	ルリアイタD (φ2.6)	NEEDLE HOLE PLATE, D (φ2.6)	
			<厚物用>	<For heavy materials>	
E	S10212101	1	ルリアイタE (φ2.6)	NEEDLE HOLE PLATE, E (φ2.6)	*
			<中厚物用>	<For medium materials>	
F	S10213001	1	ルリアイタF (φ2.2)	NEEDLE HOLE PLATE, F (φ2.2)	*
			" オプション部品"	"OPTION PARTS"	
ED	S30925001	1	ルリアイタED (φ3.4)	NEEDLE HOLE PLATE, ED (φ3.4)	
FD	S30926001	1	ルリアイタFD (φ2.2)	NEEDLE HOLE PLATE, FD (φ2.2)	
H	S30450001	1	ルリアイタH (φ2.6)	NEEDLE HOLE PLATE, H (φ2.6)	
L	S25127001	1	ルリアイタL (φ3.3)	NEEDLE HOLE PLATE, L (φ3.3)	
M	S34348001	1	ルリアイタM (φ4.0)	NEEDLE HOLE PLATE, M (φ4.0)	
3	S40217001	1	ルリアイタ3サケリ (φ3.0)	NEEDLE HOLE PLATE, 3 (φ3.0)	

151-V41

*印の部品は、標準部品です。

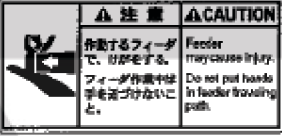
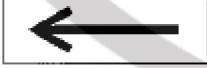
The * symbol is for standard parts.

警告ラベル / Warning labels	品名 / Name of parts	Size(mm)	Code
	電撃ラベル・和	40 X 64	S38353-101
	Label, elec. shock 4 lang.	35 X 118	S38352-101
	操作注意ラベル・(BAS)和	52 X 84	S38357-002
	Label, operation (BAS) Eng.	52 X 84	S38571-002
	はさみこみ注意ラベル・和英 Label, pinch	40 X 84	S38355-001
	矢印マーク Label, arrow	10 X 30	S37058-001
	PE マーク Label, PE	7.5 X 12.5	S37059-001
	アースマーク Label, grounding	φ 12	S37060-001

索引 / INDEX

CODE	page	REF.NO	CODE	page	REF.NO	CODE	page	REF.NO	CODE	page	REF.NO
002300403	82	1-1-15	014760622	60	28	018301036	88	1-1-7	018681232	88	1-1-4
	82	1-2-11		66	34	018301236	88	1-1-6	021060102	84	1-19
002300603	80	1-14	014770622	14	7	018302032	94	2-1-2		84	7
002301203	78	18		16	36-1-2	018400532	34	14-11	021060106	6	144
002501002	2	45		16	36-2-2	018400822	36	14-19		12	144
	8	45		20	49	018400832	18	1-18	021100202	84	1-10
002501003	4	92		20	52		34	1-17	021160306	84	1-1-17
	10	92		20	55	018401022	100	11-4	021300103	28	209-2
004300513	18	14-3		20	64	018401036	22	73		28	210-2
	18	14-8		22	83		38	73		44	209-2
	34	14-3		22	85	018401236	18	1-1-6		44	210-2
004400603	82	1-1-7		22	96		18	1-1-8	021400106	72	45
	82	1-2-3		36	49	018401436	34	1-1-2	021400206	70	1-31
004401014	38	117-3		36	52		34	1-1-3	021400216	18	1-1-9
008400604	22	140		36	55	018401622	34	1-8		34	1-1-4
	38	140		36	64	018501022	20	26	021500106	74	5
	64	L8-3		38	83		20	31		80	9
	70	1-21		38	85		20	114		102	30-8-3
013760612	56	26		38	96		36	26		104	30-11-1
014400432	90	2-1-15		60	1-2		36	31	021500216	88	1-1-23
014500522	22	141-5		60	13		36	114	021660102	2	20-4
	22	142-5		60	38-1	018501036	90	2-1-3		8	20-4
	40	141-5		14	15-1-2	018501222	4	61	021660306	28	204-2-3
	40	142-5		14	15-1-4		10	61		44	204-2-3
014680422	18	1-3		14	17		18	4	021680202	58	1-28
	18	1-16-2		16	50-2		32	237-3		60	34
	20	29		16	50-4		32	238-3	021680212	22	146
	34	1-15-2		50	16-1		34	4		40	146
	36	29	017062503	84	1-16		60	37		66	38
	58	1-14	017081606	4	57		88	1-12	021710102	66	1-11
	58	1-20		10	57		90	2-10	021750102	46	7
014680622	50	3	017101606	84	1-1-1		100	11-8	025030133	28	209-5
014710522	24	11-1-6		84	1-1-4	018501236	90	2-1-9		28	210-5
	24	11-2-6	017102006	84	1-1-12	018501422	50	25		44	209-5
	28	211-2-6	017501216	88	1-1-22	018501436	90	2-1-7		44	210-5
	32	260-6	017751412	46	9	018501622	18	1-26	025030135	48	1-9
	42	11-6	017761212	4	69		22	78	025030232	48	6-1-3
	44	260-6		10	69		22	89		74	1-8
	90	2-1-13	017821813	94	2-3		34	1-25		74	12-8
014760622	4	76	018061622	36	17		38	78		88	1-8-5
	4	90	018061636	22	135		38	89		90	2-7-5
	4	97		38	135	018502522	20	57	025030236	82	1-1-17
	10	76	018062022	20	37		20	116		82	1-2-13
	10	90		36	37		22	91	025040132	18	1-19
	10	97	018062036	96	7-1-3		22	91		34	1-18
	14	4	018081622	84	1-3		24	6		36	14-20
	14	14	018081636	80	7		24	6	025040236	6	122
	14	21	018082022	4	54		36	57		12	122
	16	31		4	87		36	116		72	44
	16	43		10	54		38	91	025050232	2	46
	18	1-17		10	87		42	6		8	46
	18	1-22		20	43		78	6		20	58
	18	21		36	43	018502536	22	143		22	90
	22	76	018082522	6	150		40	143		36	58
	34	1-16		12	150	018503022	20	59		38	90
	34	1-21	018123522	4	74		36	59		78	8
	38	76		10	74	018503536	66	15	025050233	4	93
	46	1-2	018300532	18	14-5	018680522	96	8-3-13		10	93
	50	6		34	14-5	018680822	20	41	025050236	80	6
	50	13	018300836	36	21		30	235-3		84	1-1-10
	50	21		88	1-1-20		30	236-3	025060132	18	18
	58	4		88	1-1-21		36	41		36	18
	60	10	018301036	40	144	018681022	64	L6	025060232	4	70

CODE	page	REF.NO	CODE	page	REF.NO	CODE	page	REF.NO	CODE	page	REF.NO
025060232	10	70	028040242	78	22	048060342	16	33	062300616	78	27
	84	5		100	11-5		16	44		90	2-1-29
025060236	22	137	028040246	18	1-1-7		22	141-4	062301205	82	1-1-10
	38	137	028050242	4	62		22	142-4		82	1-2-6
	82	1-1-4		10	62		40	141-4	062301616	48	1-13
025080132	4	103		78	7		40	142-4	062302505	88	1-8-3
	10	103		100	11-9		60	27		90	2-7-3
025080232	6	118	028050246	84	1-1-9		66	33	062302506	74	1-6
	12	118		102	30-8-2	048070342	60	11		74	12-6
	84	1-5	028060242	84	1-18	048080342	20	47		82	1-1-25
025100132	20	132		84	6		20	62	062400616	6	121
	36	132	028060246	22	136		22	81		12	121
	84	1-11		38	136		22	94	062400806	68	P2
025100236	84	1-1-3		96	7-1-4		36	47	062400812	76	35
	84	1-1-6	028080242	4	117		36	62	062404005	88	1-8-10
	84	1-1-14		10	117		38	81		90	2-7-10
025350132	88	1-1-14		84	1-4		38	94	062501006	90	2-1-19
025350134	32	239-6	028100242	84	1-12		50	9	062501406	104	30-11-2
	32	240-6	028100246	84	1-1-2		50	26		104	30-11-4
025350332	4	107		84	1-1-5	048100142	84	1-8	062660412	50	20-3
	10	107		84	1-1-13	048150142	14	11		52	20-4-1-3
	66	46	028350242	48	6-1-8	048280242	4	52	062660712	50	20-7
	74	26		60	12-6		10	52	062660712	52	20-4-1-7
	78	43	032422003	104	41	052400606	82	1-1-20	062670412	56	29
025680132	68	P7	037200615	64	M1-10		82	1-2-16	062670512	2	20-7
025680232	2	33		64	M1-13	052400806	100	11-1-1-10		8	20-7
	8	33	037300816	80	1-12	060400616	4	41	062670612	48	4
	18	10	037301015	64	M1-6		10	41		54	4
	20	68	037521016	84	1-1-8	060670512	96	8-3-12		54	18
	22	104	039411215	84	11		96	8-3-15		54	24
	24	11-1-13	047140850	30	235-7		96	8-3-17		56	4
	24	11-2-13		30	236-7	060670612	48	6-1-9		58	1-7
	30	214-1-7		32	237-7		48	6-3		66	3
	34	10		32	238-7		56	6		76	28
	36	68		90	2-1-25		56	4-2		78	13
	38	104	047201042	58	1-26		78	44		78	15
	60	20	047251640	54	25	060680512	64	L19		78	24
	60	33	047502242	4	78		96	8-4		78	30
	88	1-5		10	78		98	9-2		78	38
	90	2-5	048020342	48	1-10	060680712	22	70	062670616	32	239-7
025710232	2	113		30	235-6		22	101		32	240-7
	8	113		30	236-6		38	70		90	2-1-23
	86	15		32	237-6		38	101	062670812	2	9
025750132	64	L16		32	238-6	061300616	18	16		2	21
025800332	84	1-17		34	14-14		36	16		8	9
026030232	2	20-5		34	14-17	061660806	2	20-3		8	21
	8	20-5		64	L15		8	20-3		74	25
026050136	104	30-11-5		90	2-1-27	062060806	72	57		78	42
028030242	74	1-7	048040342	18	1-8	062300412	34	14-8		94	4-5
	74	12-7		34	1-6	062300503	28	209-4	062671012	60	6
	88	1-8-4		46	25		28	210-4	062680512	24	11-1-14
	90	2-7-4		64	L20		44	209-4		24	11-2-14
028030243	28	209-3		66	1-6		44	210-4		30	214-1-8
	28	209-6		66	36	062300512	18	15		64	L22
	28	210-3	048050342	18	1-14		36	15	062680612	2	32
	28	210-6		34	1-13		84	1-22		4	110
	44	209-3		58	1-9	062300612	18	14-2		8	32
	44	209-6		58	1-16		30	235-9		10	110
	44	210-3	048050346	82	1-1-19		30	236-9		54	9
	44	210-6		82	1-2-15		32	237-9		54	38
028030246	40	145	048060142	82	1-1-3		32	238-9	062680712	58	1-25
	82	1-1-16	048060342	4	104		48	6-1-2	062680812	12	148
	82	1-2-12		10	104		48	6-1-6		14	20-1-7

CODE	page	REF.NO	CODE	page	REF.NO	CODE	page	REF.NO	CODE	page	REF.NO
062680812	14	20-2-7	0A5400806	78	17	107415014	16	27	139096001	34	1-15-1
	14	20-3-8		96	7-7	107415016	16	27	140379001	16	36-1-1
	20	67	0A5401006	70	1-7	107415018	16	27	140380001	16	36-2-1
	22	103		76	39	107415019	16	27	140392009	2	17
	36	67	0A5401206	70	1-30	107415021	16	27		8	17
	38	103	0A5401605	72	43	107415023	16	27	140651001	16	34
	38	127	0A5403006	70	1-5	107419002	28	213	140726000	14	8
	54	16	0B1351606	104	42		44	213	141331001	60	21-2-2
	66	41	100022005	66	11	107453001	46	6	141492001	60	21-2
062681012	2	26	100032004	96	7-2	107606001	56	16-2	141493001	60	21-2-1
	8	26		96	8-2	107780001	102	25	141499001	100	11-1-1-7
	22	99	100136001	56	22	108802001	54	41	141550001	58	1-4
	38	99		58	1-29		54	42	141590001	58	1-34
	60	4	100242003	88	1-1-15	109239002	2	12	141786001	50	1
	66	5	100250001	14	16		8	12	142211001	14	22
062681212	46	22	100360003	62	56	110146001	60	30	142268001	54	3
062681412	24	5-1-3	100402004	56	19	110161004	66	19		54	23
	24	5-2-3	100645003	24	5-1-4	110168001	18	1-10		54	27
	42	5-3		24	5-2-4		34	1-9		78	37
	68	P6		42	5-4	110367001	60	26	142443001	102	21
062681612	24	11-1-3		64	L7		66	32	142566001	58	1-13
	24	11-2-3		66	37	110494001	50	10	142721001	102	26
	28	211-2-3	100887001	102	24	110735001	64	L14	142990001	104	30-10-3
	32	260-3	101073001	84	1-21	111140002	62	52	143591001	18	1-15
	42	11-3	101482001	14	5	111466101	46	15		34	1-14
	44	260-3	101572101	102	23	113006001	54	32	144105000	58	1-32
062710612	56	2	104525001	56	16-1	113316001	56	5	144110001	58	1-30
062710812	2	24		94	2-6	113730001	96	8-3-5	144458001	16	24
	8	24	104567101	54	11		96	8-3-10		64	L24
062711012	2	7	104689002	50	2	114294001	56	10	144504001	48	1-2
	2	39	104832001	24	5-1-5	114483002	102	28		94	2-1-11
	8	7		24	5-2-5	114486002	4	83	144588001	56	11-2
	8	39		42	5-5		10	83	144712001	14	2-1
	58	6	105073001	84	1-24	115012002	90	2-1-16	145087001	88	1-1-11
	86	14	105343001	104	36	115157001	104	32	145446001	56	18
062711212	2	35	106129002	60	12-5	115183101	58	5	145446001	56	24
	8	35	106147002	60	15	115186001	56	21		58	1-31
	58	2	106588003	60	21-3	115188001	56	23		14	20-1-4
062711412	2	6	106629002	4	71	116735000	14	20-1-8		14	20-2-4
	8	6		4	116		14	20-2-8		14	20-3-5
	96	7-4		10	71	116922001	56	13	145472001	46	16
062771012	12	149		10	116	117150001	54	17	145519001	56	11-1
	66	6		22	106	117160001	12	145	145646011	16	27
070638800	4	51		22	108	117291002	88	1-3	145646014	16	27
	10	51		38	106	117934001	2	5	145646016	16	27
072630260	14	9		38	108		8	5	145646018	16	27
076000850	20	46		38	123		96	7-3-3	145646019	16	27
	20	61		38	125	117936001	2	18	145646021	16	27
	22	80	107017001	80	1-20		8	18	145646024	16	27
	22	93	107017002	2	29		48	6-5	145646025	16	27
	36	46		8	29		82	1-1-21	146020001	78	55
	36	61		24	11-1-10		82	1-2-17	146058001	48	1-4
	38	80		24	11-2-10	118064001	102	27		94	2-1-9
	38	93		30	214-1-5	118735001	66	18	146059001	48	1-5
081003670	50	15		42	11-10	118837001	102	22		94	2-1-8
	50	23	107093002	60	19	119755001	84	4	146060000	48	1-6
0A4300605	80	1-6	107149001	54	30	120448001	58	1-19		94	2-1-7
	80	1-11	107321003	2	28	122991001	102	20	146080000	48	5
0A4301005	70	1-27-18		8	28	123006001	50	7-1		78	25
0A4400605	72	41		66	1-10	129986001	2	30	146206009	48	1-3
0A5400805	80	1-5	107321009	80	1-19		8	30		94	2-1-10
0A5400806	54	45	107415009	16	27	133172003	84	1-1-7	146255000	86	24
	70	1-6	107415011	16	27	139096001	18	1-16-1	146256001	86	23

CODE	page	REF.NO
146288001	64	L18
146354001	18	1-7
	34	1-5
147476001	66	1-8
147763101	14	6
147777000	14	20-3-9
148196000	46	11
148197000	46	12
148294001	58	1-33
148764001	66	17
148813001	60	12-4
148847001	54	39
	66	45
	76	36
149287000	94	2-7
149482001	18	13
	34	13
149547000	54	44
	66	40
	78	14
149796001	74	6
149809000	64	M3
	72	54
	72	56
	74	23
	78	32
	80	1-16
149831101	88	1-1-12
150173003	102	30-7
150174000	102	30-4-3
	102	30-5-1
150179002	102	30-8-1
150182000	102	30-2
150183000	104	30-10-2
150206002	102	30-4-1
150335001	104	37
150382001	38	112
	100	11-6-1
150451001	96	7-1-6
150460001	46	4
150461001	46	5
150551000	56	12
150553003	58	1-35
150554002	90	2-1-17
151927001	54	33
152237101	14	20-1-3
152243001	16	26
152283101	46	26-13
	106	A
152632001	28	209
	44	209
152633001	28	210
	44	210
152636101	46	26-14
	106	B
152637001	46	26-15
	106	C
152678201	50	14
	50	22
152681201	50	24
152682101	50	27-1
152683101	50	20-4
	52	20-4-1-4

CODE	page	REF.NO
152684101	50	20-5
	52	20-4-1-5
152686101	50	27-2
152861101	84	1-6
152862001	84	1-7
152863001	84	1-15
152864000	84	1-14
152865201	84	1-9
152869001	56	1
152870001	56	3
152872001	56	9
152881001	56	25
152883000	56	27
152884001	56	28
152889001	48	6-4
152891101	56	33
152933001	58	1-17
152936001	58	1-5
152937001	58	1-6
152940001	58	1-10
152948001	54	1
152955001	54	8-2
152984052	58	1-3
153057102	18	9
	34	9
153138001	96	7-1-7
	96	7-1-10
153242000	70	1-27-15
	102	10
153403002	88	1-4
	90	2-4
153597001	60	12-2
153718001	2	11
	8	11
153941001	66	4
154069001	46	26-16
	106	D
154089001	46	26-17
	106	E
154235001	88	1-1-9
154236001	88	1-1-10
154237001	88	1-1-13
154256101	88	1-6
154528001	58	1-18
154596000	16	38
154623000	16	50-1
154624101	14	20-2-3
154763010	16	27
155067001	90	2-1-14
155167002	46	14
155510001	48	1-7
	94	2-1-6
156070002	20	50
	36	50
156112003	102	30-6
157237001	46	26-7
	102	16
	106	F
157255100	48	1-8
157828001	16	46
157829001	16	41
157968001	58	1-24
158384001	62	53

CODE	page	REF.NO
158592001	46	26-6
	106	G
159224001	56	7
159264001	66	31
159269001	24	11-1-9
	24	11-2-9
	30	214-1-4
	42	11-9
	100	11-1-1-3
159486001	58	1-8
159574101	58	1-27
159805001	56	17
159905001	60	14
159947001	16	45
183305001	16	36-2
183816001	16	36-1
183827001	60	38
228475000	72	7
	76	37
	78	39
	78	45
	82	1-1-11
	82	1-2-7
	94	4-6
231071001	60	8
232384001	70	1-27-7
340400001	54	36
	78	40
	88	1-9
	90	2-11
	94	2-5
402887001	50	20-6
	52	20-4-1-6
417382001	80	1-3-5
525567000	96	7-8
525664000	76	38
	96	7-6
530138001	22	141-3
	22	142-3
	40	141-3
	40	142-3
533527001	100	11-1-6
552907000	74	27
	78	41
552908000	78	16
623033000	46	1-3
625010000	48	6-2
	78	12
	100	11-1-5
S00480000	74	24
S00554000	70	1-16
S00617000	86	25
S00705001	62	49
S01005000	102	30-4-4
S01565000	74	9-1
S01696001	26	203-1-3
	26	203-2-3
	26	203-3-3
	26	203-4-3
	26	203-5-3
	26	203-6-3
	42	203-1-3
	42	203-2-3

CODE	page	REF.NO
S01696001	42	203-3-3
S01998001	58	1-12
S02268001	14	20-1-6
	14	20-2-6
	14	20-3-7
S02269001	16	23
S02301001	100	11-1-1-6
S02354001	60	17
S02429101	50	20-2
	52	20-4-1-2
S02438001	56	32-1
S02439001	56	32-2
S02445001	4	106
	10	106
S02617001	48	6-1-7
S02657101	48	6-6
S02672002	64	L21
S02677001	64	L23
S02678001	64	L25
S02739000	84	10
S02740000	84	9
S02747101	102	30-4-5
S02763402	102	30
S02777001	102	30-4
S02778002	102	30-9
S02786002	102	30-10
S02787002	104	30-10-1
S02853001	28	212-1
	44	212-1
S02854001	28	212-2
	44	212-2
S02855001	28	212-3
	44	212-3
S02907000	80	1-8
S03403001	66	20
S03487001	4	53
	10	53
S03611001	16	47
S03677001	20	27
	20	32
	36	27
	36	32
	46	28
S03695001	66	21
S03704002	50	16
S03792001	74	1-5-3
	74	12-5-3
	88	1-8-11
	90	2-7-11
	94	2-2-6
	94	4-3-6
	94	6-5
S03801101	18	1-9
S04505000	78	34
S04557000	100	11-1-8
	100	11-12
S04754000	84	1-1-18
S04887001	46	26-12
	106	I
S04897000	94	4-4
	98	9-4
S04905000	66	14-2
	100	11-1-1-8-2

CODE	page	REF.NO	CODE	page	REF.NO	CODE	page	REF.NO	CODE	page	REF.NO
S05636001	74	1-5-1-1	S10208001	102	4-1	S15031008	94	4-2	S17873101	46	13
S05665001	88	1-1-8	S10208002	62	45-2		98	9-1-5	S17896001	50	11
S05792000	74	21		102	4-2		100	11-11	S17901000	54	2-2
S06143000	78	33	S10208003	62	45-3	S15031010	96	7-5	S17902000	54	2-4
	84	12		102	4-3	S15158009	84	8	S17903000	54	7
S06696004	28	209-1	S10209101	62	50	S15665001	50	32-1	S17905000	54	8-3
	28	210-1	S10210201	62	51-1		102	1-1		54	34
	44	209-1	S10211001	62	55-1	S15666001	50	32-2	S17906000	54	8-4
	44	210-1		108	A		102	1-2	S17907201	54	12
S06706001	102	5	S10212101	62	55-2	S15667001	50	30-1-3	S17908000	54	13
S06715002	84	1-1-16		108	E		50	30-2-3	S17910000	54	14
S08030000	70	1-27-16	S10213001	62	55-3	S16075101	50	30-2-1	S17911000	54	15
	102	9		108	F	S16290001	50	29	S17916001	58	1-1
S08178000	100	11-13	S10217101	64	L13	S16492101	50	30-1-2	S17918201	60	7
S08967001	16	48	S10228001	66	1-3		50	30-2-2	S17922001	60	18
S09021100	104	44	S10229101	66	1-4	S16568000	70	1-8	S17923001	60	31
S09043000	50	20-8	S10232001	66	44	S16589100	78	21	S17924101	60	35
	52	20-4-1-8		76	34	S16996000	98	9-1-2	S17925000	60	36
	54	40	S10239001	66	39	S16997100	98	9-1-4	S17929001	60	42-1
S09228000	74	1-4	S10243000	66	2	S17800101	2	22	S17933001	66	1-1
	74	12-4		78	23		8	22	S17934001	66	1-2
S09318101	74	1-2	S10267001	60	21	S17801000	2	23	S17937001	66	1-7
	74	12-2	S10268001	58	1-22		8	23	S17945101	66	30
S09378001	26	203-7	S10352101	22	112	S17803001	2	27	S17949001	66	35
S09379001	26	203-8		88	1-14		8	27	S17951109	2	34
S09380001	26	203-9		100	11-3	S17809009	18	1-24	S17952009	2	37
S09989000	104	34	S10364001	54	2-1		34	1-23		8	37
S10029209	2	8	S10371001	46	23	S17811001	18	1-6	S17956001	4	66
	8	8	S10372100	46	24	S17812001	18	1-11	S17957001	4	67
S10030002	2	10	S10408000	80	8		34	1-10	S17958001	4	68
	8	10	S10438001	58	1-15	S17813001	18	1-12	S17959001	4	72
S10036101	14	2	S10469001	56	20		34	1-11		10	72
S10038001	14	3	S10470101	64	L17	S17814001	18	1-13	S17960000	4	73
S10040001	14	15-1-1	S10478000	54	2-3		34	1-12		10	73
S10044001	16	25	S10661109	84	1-1-15	S17815000	20	131	S17962100	4	77
S10091201	22	69	S11243001	104	31		36	131		10	77
	38	69	S11244001	62	54	S17816001	18	1-20	S17963001	4	79
S10103001	20	33	S11314101	50	5		34	1-19		10	79
	36	33	S11426000	96	7-1-2-1	S17817009	18	1-23	S17965001	4	84
S10111101	46	19		100	11-1-1-8-1		34	1-22		10	84
S10112001	46	20	S11762000	76	33	S17823100	18	1-25	S17966101	4	85
S10145001	50	4	S11884001	48	6-1-5		34	1-24		10	85
S10149101	50	12	S12150000	94	2-1-3	S17825001	18	2	S17967001	4	86
S10155000	54	5	S12212000	74	9-2		34	2		10	86
S10156000	54	6	S12441001	56	14	S17826001	18	3	S17968001	4	88
S10162201	54	10	S12634009	88	1-1-1		34	3		10	88
S10172001	58	1-2	S12635009	88	1-1-2	S17829001	24	5-1-2	S17969001	4	89
S10173001	58	1-11	S12637009	88	1-1-16		24	5-2-2		10	89
S10174000	58	1-21	S12638009	88	1-1-5		42	5-2	S17971000	4	94
S10175001	58	1-23	S12639001	88	1-1-17	S17836001	24	11-1-2		10	94
S10178001	60	3	S12640009	88	1-1-19		24	11-2-2	S17972001	4	95
S10179001	60	5	S12642009	88	1-1-18		28	211-2-2		10	95
S10189001	60	16	S13007001	28	204-2-2		32	260-2	S17973001	4	96
S10191001	60	21-1		44	204-2-2		42	11-2		10	96
S10192001	60	22	S13399001	46	27		44	260-2	S17974001	4	101
	60	32	S13695001	26	203-10	S17837001	24	11-1-4		10	101
S10193001	60	23	S13697001	26	203-11		24	11-2-4	S17975100	4	102
S10194001	60	24	S13698001	26	203-12		28	211-2-4		10	102
S10195001	60	25	S13815001	46	26-18		32	260-4	S17979001	26	202-1
S10196101	60	29		106	J		42	11-4	S17981001	26	202-2
S10204101	62	43	S15031008	88	1-10		44	260-4	S17983000	26	203-1-1
S10205001	62	44-1		90	2-12	S17871101	46	8	S17994001	84	1-1-11
S10208001	62	45-1		94	2-4	S17872101	46	10	S17997001	84	1-2

CODE	page	REF.NO	CODE	page	REF.NO	CODE	page	REF.NO	CODE	page	REF.NO
S18014001	24	11-1-5	S19636001	30	214-1-1	S21724001	26	202-6	S31259101	44	204-1
	24	11-2-5	S19637001	30	214-2	S21774001	50	7	S31260101	44	204-1-1
	28	211-2-5	S19638001	30	214-3	S21775001	18	1-16	S31261001	44	205-2
	32	260-5	S19643000	28	207-2		34	1-15	S31262000	44	206
	42	11-5	S19644000	28	208-2	S21798001	102	30-8	S31263000	44	207-1
	44	260-5	S19817001	96	7-1-9	S23443000	18	1-2	S31264000	44	207-2
S18026001	24	11-1-12	S19914001	28	211-2	S23651001	32	239-4	S31265000	44	208-1
	24	11-2-12	S19915001	28	211-2-1		32	240-4	S31266000	44	208-2
	30	214-1-6	S19997109	88	1-1	S23839001	16	30	S31273001	44	211
S18027101	94	4-1	S19998001	88	1-1-3	S23840001	16	32	S31551209	74	1-1
S18032001	48	1-1	S19999001	88	1-13	S23841001	16	42	S31554109	74	12-1
S18037009	48	1-12	S20000001	88	1-2	S24511007	16	27		94	2-2-5
S18038101	18	1-4	S20006000	88	1-11	S24590001	18	20		94	4-3-5
S18039000	4	108		90	2-13	S24593001	16	35	S31570409	88	1-8-1
	102	19-1	S20083000	100	11-1-2	S24675001	2	2		90	2-7-1
S18055001	60	41	S20282001	30	235-2		8	2	S31612001	62	44-2
S18103001	84	1-20	S20283001	30	235-4	S24729000	90	2-1-5	S31760000	70	1-17
S18344209	86	13		30	236-4	S25127001	62	55-4	S31808001	100	11-6-2
S18375101	74	12-5-1-1	S20284001	30	235-5		108	L	S32035001	30	225
	88	1-8-2		30	236-5	S25154009	2	2-1		44	225
	90	2-7-2		90	2-1-24		8	2-1	S33251001	46	30
	94	2-2-3	S20285001	30	235-8	S25155100	2	2-2	S33252001	54	37
	94	4-3-3		30	236-8		8	2-2	S33720001	44	204-2
S18382000	98	9-1-3		32	237-8		96	7-1-12	S33721001	44	204-2-1
S18415101	74	1-5-2		32	238-8	S25310101	100	11-14-3	S33722001	32	239-5
	74	12-5-2		90	2-1-26	S25373000	50	20-9		32	240-5
	88	1-1-24	S20288001	30	236-2		50	20-10	S33956000	94	6-3
	88	1-8-8	S20755001	28	205-2		52	20-4-1-10	S34156001	30	233
	90	2-1-30	S20756001	30	218	S25458001	64	L3	S34157001	30	234
	90	2-7-8	S20864001	46	26-11		64	L11	S34158001	30	235
	94	2-2-4		106	GL	S25634101	80	5	S34159001	30	235-1
	94	4-3-4	S20952101	86	17	S29023000	80	1-3-1	S34160001	30	236
	94	6-4	S20953001	84	1-25	S29468100	48	6-1-4	S34161001	30	236-1
S18538000	2	36	S21118001	4	111	S29997001	62	55-5	S34162001	32	237
	8	36		10	111		108	D	S34163001	32	237-1
S18636101	18	1-21	S21151001	90	2-1-1	S30033001	60	12-3	S34164001	32	238
	34	1-20	S21152001	90	2-1-2	S30117101	60	12-1	S34165001	32	238-1
S18653001	60	1-1	S21153000	90	2-1-11	S30128001	62	51-2	S34166001	32	237-2
S18919001	60	9		90	2-1-21	S30450001	62	55-6	S34167001	32	238-2
S19543001	96	8-3-7	S21154001	90	2-1-18		108	H	S34168001	32	237-5
S19593000	26	203-2-1	S21156000	90	2-1-4	S30925001	62	55-7		32	238-5
S19595000	26	203-3-1	S21157001	90	2-1-6		108	ED	S34169001	32	237-4
S19599001	26	202-3	S21158000	90	2-1-8	S30926001	62	55-8		32	238-4
S19600001	26	202-4	S21159001	90	2-1-10		108	FD	S34170001	32	239
S19609009	24	5-1	S21160000	90	2-1-12	S30932001	8	47	S34171001	32	240
S19610009	24	5-1-1	S21161001	90	2-1-22	S30948001	34	1-4	S34172001	32	239-1
S19612001	24	11-2-1	S21162001	90	2-1-20	S30950000	34	1-2	S34173001	32	240-1
S19613000	24	11-2-11	S21163001	90	2-1-28	S30951001	34	1-7	S34174001	32	239-2
S19615000	26	203-4-1	S21167001	90	2-2	S30957001	60	42-2		32	240-2
S19617000	26	203-5-1	S21168001	92	5-1	S30995000	42	203-1-1	S34175001	32	239-3
S19619000	26	203-6-1	S21169001	92	5-2-1	S30997000	42	203-2-1		32	240-3
S19620009	24	5-2	S21170001	92	5-2-2	S30999000	42	203-3-1	S34348001	62	55-10
S19621009	24	5-2-1	S21171001	90	2-3	S31012001	46	17		108	M
S19626000	24	11-1-11	S21476001	90	2-9	S31013001	46	18	S34413000	70	1-26
S19629001	28	204-1-2		92	4-1	S31032001	56	15	S34533001	94	2-1-4
	28	204-3-2	S21476002	92	4-2	S31134001	92	6	S34534101	94	2-1-5
	44	204-1-2	S21505109	90	2-1	S31164009	42	5	S34536101	94	2-1-12
S19630001	28	205-1	S21506001	92	3-1	S31165009	42	5-1	S34706000	94	2-1-1
	44	205-1	S21507001	90	2-6	S31168000	42	11-11	S35324001	22	134
S19631000	28	206		92	3-2-1	S31244001	42	202-1		38	134
S19632000	28	207-1	S21508001	92	3-2-2	S31245001	42	202-2	S36008009	80	1-18
S19633000	28	208-1	S21527001	54	8-1	S31258001	42	201-1	S36260000	82	1-1-9-2
S19634001	28	211-1	S21723001	26	202-5	S31257001	42	201-2		82	1-2-5-2

CODE	page	REF.NO	CODE	page	REF.NO	CODE	page	REF.NO	CODE	page	REF.NO
S37058001	109	Wa	S38208000	70	1-27-14	S42867001	82	1-2-2	S43981000	64	M1-17
S37059001	70	1-23	S38352101	72	20	S42890001	104	40	S44483001	2	20-1
	109	Wa		109	Wa	S43169109	70	1		8	20-1
S37060001	70	1-24	S38353101	72	21	S43170109	70	1-1	S44485001	2	20-2
	109	Wa		109	Wa	S43171009	70	1-2		8	20-2
S37064101	14	15-1	S38355001	109	Wa	S43172009	70	1-3	S44486101	2	20-6
S37066001	60	1	S38357002	109	Wa	S43175000	70	1-27-11		8	20-6
S37761101	100	11-1	S38571002	109	Wa	S43176000	70	1-27-12	S44493101	2	20
S37762101	100	11-1-1	S38648001	102	30-4-2	S43177000	70	1-27-1		8	20
S37763101	100	11-1-1-1	S39110001	18	17	S43181000	70	1-27-13	S44663100	78	10
S37764001	100	11-1-1-2	S39973001	14	15-1-3	S43184000	70	1-27-2	S44746100	74	11-1
S37765001	100	11-1-1-4	S40214001	46	26-10	S43186000	70	1-15		74	12-5-5-1
S37766001	100	11-1-1-5		106	A-CUT	S43187000	70	1-27-20		88	1-8-7-1
S37767000	100	11-1-1-8	S40217001	62	55-9	S43189000	70	1-27-19		90	2-7-7-1
S37768001	100	11-1-1-9		108	3	S43191000	72	11		94	2-2-2-1
S37769001	100	11-1-3	S40417151	4	105	S43201000	72	3-1		94	4-3-2-1
S37770001	100	11-1-4		10	105	S43224000	80	1-9		94	6-2
S37771001	100	11-2-2	S40616001	72	40	S43225000	80	1-10	S44750100	74	11-2
S37772101	100	11-14	S40621000	64	M2	S43228000	80	1-13		74	12-5-5-2
S37773001	100	11-14-1		72	50	S43236009	80	2		88	1-8-7-2
S37774001	100	11-14-2	S40622000	72	51	S43237100	80	1-7		90	2-7-7-2
S37775001	100	11-2-1	S40623000	72	42	S43249101	64	M1		94	2-2-2-2
S37776101	100	11-7	S40624000	72	46	S43250100	64	M1-1		94	4-3-2-2
S37780000	100	11-1-7	S40628000	74	1-3	S43251000	64	M1-2	S44805101	82	1-2
S37928019	16	27		74	12-3	S43252000	64	M1-3	S44806000	82	1-2-5
S37929009	16	27	S40629000	74	1-9	S43253000	64	M1-4	S44807000	82	1-2-5-1
S37929016	16	27		74	12-9	S43254100	64	M1-5	S45252000	88	1-8-9
S38035109	14	13	S40640001	102	30-5	S43255000	64	M1-7		90	2-7-9
S38041000	84	1-23	S40641001	104	30-11	S43256000	64	M1-8	S45253000	88	1-8-9-1
S38059000	64	L10	S40764000	72	52	S43259101	64	M1-18		90	2-7-9-1
	82	1-1-24		72	55	S43267000	64	M1-14	S45254000	88	1-8-9-2
	82	1-2-20	S40846001	62	44-4	S43268000	64	M1-15		90	2-7-9-2
S38060000	82	1-1-23	S40934101	62	44-3	S43269000	64	M1-19	S46144100	66	14
	82	1-2-19	S41202151	78	26	S43270000	64	M1-16	S46145000	66	14-1
S38080001	68	P4	S41205001	64	L2	S43271000	64	M1-11	S46433000	78	2
S38082001	68	P5	S41206001	64	L1	S43272000	64	M1-12	S46435000	78	3
S38093000	70	1-29	S41207000	64	L4	S43273000	104	33	S46436000	78	4
S38094100	70	1-4	S41222101	56	32-3	S43275000	70	1-18	S46437000	78	20
S38104000	80	1-3-4	S41523000	96	7-1-2-2	S43276000	70	1-19	S46439000	78	29
S38107100	70	1-11	S41524000	96	7-1-2-3	S43277000	70	1-20	S46440109	72	H-1
S38108000	70	1-12	S42258000	82	1-1-9-1	S43278000	72	31	S46441109	72	H-2
S38109100	70	1-13	S42259000	82	1-1-9	S43279300	48	6-1-1	S46442109	72	H-3
S38110000	70	1-14	S42260000	70	1-10	S43309000	70	1-22	S46443109	72	H-4
S38122200	70	1-9	S42653000	72	53	S43318000	70	1-25	S46444109	72	H-5
S38155000	68	Q1-2		80	1-15	S43369000	72	3-2	S46445109	72	H-6
S38166000	82	1-1-1	S42658000	104	35	S43370000	72	3-3	S46446109	72	H-7
	82	1-2-1	S42842101	82	1-1	S43674000	80	3	S46447109	72	H-8
S38167001	82	1-1-2	S42843001	46	26-1	S43675000	80	4	S46448109	72	H-9
S38168001	82	1-1-5		106	A	S43686000	74	1-10	S46449001	68	Q1
S38170001	82	1-1-8	S42844001	46	26-2		74	12-10	S46460000	84	1-13
	82	1-2-4		106	B	S43693000	46	2	S46842001	96	8-3-3
S38174000	82	1-1-12	S42845001	46	26-3	S43696100	74	11		96	8-3-8
	82	1-2-8		106	C		74	12-5-5	S47069009	2	38
S38175001	82	1-1-13	S42846001	46	26-4		88	1-8-7		8	38
	82	1-2-9		106	D		90	2-7-7	S47070001	4	40
S38176101	82	1-1-14	S42847001	46	26-5		94	2-2-2		10	40
	82	1-2-10		106	E		94	4-3-2	S47071009	2	43
S38177001	82	1-1-18	S42848001	46	26-8	S43834109	48	1		8	43
	82	1-2-14		106	J	S43835100	48	1-11	S47072000	2	44
S38180000	82	1-1-22	S42849101	46	26-9	S43836301	48	6		8	44
	82	1-2-18		106	XA	S43838101	94	2-1	S47073001	4	56
S38203000	70	1-27-5	S42858001	64	L12	S43903001	66	16		10	56
	70	1-27-9	S42867001	82	1-1-6	S43977201	48	6-1	S47074001	4	50

CODE	page	REF.NO	CODE	page	REF.NO	CODE	page	REF.NO	CODE	page	REF.NO
S47074001	10	50	S47129001	38	79	S47298000	38	72	S48619000	24	7-2
S47075001	4	60	S47130100	22	88	S47300101	38	105	S48620001	24	11-1-1
	10	60		38	88	S47301101	38	107	S48621001	42	7
S47076009	4	64	S47131001	22	92	S47302001	42	203-1	S48622001	42	7-1
	10	64		38	92	S47303001	42	203-2	S48623000	34	8-2
S47077001	4	75	S47135101	22	105	S47304001	42	203-3		42	7-2
	10	75	S47136101	22	107	S47306101	38	126	S48624001	42	11-1
S47078001	4	91	S47137101	24	110	S47307001	34	14-2	S48625001	42	110
	10	91	S47138101	22	111	S47311000	34	14-9	S48626001	42	111
S47079301	4	109	S47139009	32	250	S47312001	34	14-12	S48662001	66	10
S47083009	4	114	S47140001	46	1	S47313001	34	14-13	S48664001	50	30-1-1
S47084009	4	115	S47141001	46	1-1	S47314001	34	14-15	S48665001	46	21
S47085001	6	120	S47142001	66	1-9	S47315001	34	14-16	S48666001	68	P1
	12	120	S47143001	66	1-5	S47316001	36	14-18	S49042001	22	100
S47086001	14	1	S47144101	66	12	S47317001	10	66		38	100
S47087001	14	20-1	S47151001	66	1	S47318000	10	108	S49043001	22	102
S47088001	14	20-1-1	S47154109	84	1		102	19-2		38	102
	14	20-2-1	S47161109	84	2-1	S47319001	12	146	S49044001	38	122
S47091001	14	20-1-2	S47162109	84	3-1	S47321001	34	14-10	S49045001	38	124
	14	20-2-2	S47163001	6	130	S47325001	22	97	S49056000	74	22
	14	20-3-3		12	130	S47326001	18	14-7	S49057000	74	20
S47092001	14	20-1-5	S47165000	20	22	S47327001	34	14-7	S49059101	60	40
	14	20-2-5		36	22	S47328009	84	2-2	S49071000	70	1-27-8
	14	20-3-6	S47166100	74	1-5-4	S47329009	84	3-2	S49418101	34	14-1
S47093001	14	20-2		74	12-5-4	S47370000	70	2-1	S49429109	74	1
S47096201	18	1	S47167001	78	9	S47371000	72	2-5	S49430101	74	1-5
S47097201	18	1-1	S47168001	26	203-1	S47372000	70	2-2	S49431001	74	1-5-1
S47102101	24	11-1	S47169001	26	203-1-2	S47373000	70	2-3	S49432001	74	1-5-1-2
S47103001	24	11-1-7		26	203-2-2	S47374000	70	2-4		74	10
	24	11-2-7		26	203-3-2	S47601001	32	260		74	12-5-1-2
	30	214-1-2		26	203-4-2	S47602001	32	260-1		88	1-8-6
	42	11-7		26	203-5-2	S47603001	32	261		90	2-7-6
S47104001	24	11-1-8		26	203-6-2	S47606001	32	262		94	2-2-1
	24	11-2-8		42	203-1-2	S47607001	44	260		94	4-3-1
	30	214-1-3		42	203-2-2	S47608001	44	260-1		94	6-1
	42	11-8		42	203-3-2	S47609001	44	261	S49433109	74	12
S47105001	24	11-2	S47170001	26	203-2	S47611001	44	262	S49434101	74	12-5
S47106101	18	14	S47171001	26	203-3	S47612001	26	201-1	S49435001	74	12-5-1
S47107001	18	14-1	S47172001	22	75		90	2-8	S49436109	88	1-8
S47108000	18	14-4		38	75	S47613001	26	201-2		90	2-7
S47109101	18	14-6	S47173001	20	113	S47614001	26	203-4	S49437008	94	4-3
S47111101	20	23		36	113	S47615001	26	203-5	S49437105	94	2-2
	36	23	S47174000	58	3	S47616001	26	203-6	S49443000	82	3
S47112000	20	28	S47176001	4	55	S47617001	28	204-1	S49448001	46	26-19
	36	28		10	55	S47618001	28	204-1-1		106	B-L
S47113001	20	30	S47177009	2	31	S47619001	28	204-2	S49471000	68	Q1-3
	36	30		8	31	S47620001	28	204-2-1	S49472000	70	1-27-21
S47116001	20	42	S47178001	6	140	S47621001	28	204-3	S49584000	14	15-2
	36	42		12	140	S47622001	28	204-3-1	S49586000	70	1-27-3
S47119001	20	45	S47270001	6	141	S47623001	30	214-1	S49587001	14	20-3-1
	36	45		12	141	S47624001	30	232	S49588001	14	20-3-2
S47122000	20	56		86	20	S48140002	94	2-8	S49589001	14	20-3-4
	36	56	S47277109	8	34	S48501201	94	2	S49623000	52	20-4-3
S47123001	20	60	S47278301	10	109	S48503109	94	4		54	22
	36	60	S47281109	10	114	S48507109	88	1	S49627001	56	5-2
S47125001	20	66	S47282109	10	115	S48509001	88	1-7	S49791100	72	10
	36	66	S47289101	42	11	S48511109	90	2	S49938000	80	1-2
S47126000	22	72	S47290201	34	14	S48579000	80	1-3-2	S49939101	70	1-27
S47127100	22	77	S47292000	34	14-4	S48580000	70	1-27-17	S50001000	104	43
	38	77	S47293101	34	14-6	S48590100	68	Q1-6	S51241000	80	1-21
S47128001	22	82	S47295001	10	67	S48617001	24	7	S51262001	102	30-3
	38	82	S47296001	10	68	S48618001	24	7-1	S51263001	102	30-1
S47129001	22	79	S47297001	12	147	S48619000	18	8-2	S51426000	100	11-10

CODE	page	REF.NO	CODE	page	REF.NO	CODE	page	REF.NO
S51429101	100	11	S55663001	102	29	SA1034000	70	1-27-10
S51473000	96	7-1-2	S55877001	14	18	SA1471001	34	1-1-1
S51476001	96	7-1-5		16	50-3	SA1482001	34	1-1
S51477001	96	7-1-8	S56151000	80	1-3	SA1509001	22	141
S51478001	96	7-1-11	S56167000	78	10-1		40	141
S51859101	56	3-2	S56167002	78	10-2	SA1510001	22	142
S52243000	68	Q1-1	S57926000	78	31		40	142
S52244000	68	Q1-7	S58851001	80	1	SA1511001	34	1
S52245000	72	35	S59134001	16	50	SA1512001	34	8
S52246000	68	Q1-8	S59221001	50	30-1	SA1513001	38	117
S52250000	68	Q1-5	S59222001	50	30-2	SA1584000	78	35
S52582001	64	M50	S59652000	64	M1-9	SA1645021	102	2-2
S52828101	50	20-1	S59660000	64	M1-9-1	SA1752016	102	2-1
	52	20-4-1-1	S59895001	52	20-4	SA1890001	50	28-2
S53070001	96	8-3	S59896001	52	20-4-1	SA1898001	18	19
S53071001	96	8-1	S59897001	52	20-4-1-9	SA1899001	18	12
S53072001	96	8-3-1		52	20-4-1-11	SA1900001	22	133
S53073001	96	8-3-2	S59931001	104	30-11-3	SA1901001	22	138
S53074001	96	8-3-4	SA0037000	70	1-27-6	SA1902001	22	139
S53075001	96	8-3-6	SA0684000	36	19	SA1906001	18	8
S53076001	96	8-3-9	SA0685001	36	20	SA1907001	18	8-1
S53077001	96	8-3-11	SA0688000	22	141-1	SA1911000	76	40
S53078001	96	8-3-14		40	141-1	SA1933001	18	1-1-5
S53079001	96	8-3-16	SA0687000	22	142-1	SA2173001	50	28-1
S53080001	98	9-1		40	142-1	U32744000	68	Q1-4
S53081001	98	9-1-1	SA0688001	22	141-2	U34870001	80	1-3-3
S53082001	98	9-3		22	142-2			
S53154001	96	8		40	141-2			
S53155001	98	9		40	142-2			
S53182101	2	112	SA0689001	34	12			
	8	112	SA0690001	38	133			
	86	16	SA0691001	38	138			
S54786001	96	7	SA0692001	38	139			
S54787001	96	7-1	SA0693001	22	98			
S54788001	96	7-1-1		38	98			
S54790009	96	7-3	SA0694001	20	40			
S54791009	96	7-3-1		36	40			
S54792000	96	7-3-2	SA0695001	2	25			
S54797001	94	6		8	25			
S55133000	64	L8-2	SA0696001	20	35			
S55149100	64	L5		36	35			
S55150000	64	L8-1	SA0697000	34	8-1			
S55151000	80	1-17	SA0698001	38	117-1			
S55154001	80	1-1	SA0699001	38	117-2			
S55184000	78	28	SA0747000	22	87			
S55402200	80	1-4		38	87			
S55473000	70	1-27-4	SA0748000	20	65			
S55475002	4	80		36	65			
	10	80	SA0749000	20	53			
S55476002	72	4		36	53			
S55477002	6	131	SA0750001	20	51			
	12	131		20	63			
S55485002	74	2		22	84			
S55488002	4	98		22	95			
	10	98		36	51			
S55533000	18	1-5		36	63			
	34	1-3		38	84			
S55594000	78	1		38	95			
S55649001	14	20-3	SA0751001	20	54			
S55650201	50	20		36	54			
S55651000	50	20-11	SA0752001	20	48			
S55652000	52	20-4-2		36	48			
	54	21	SA0987000	54	43			

brother®

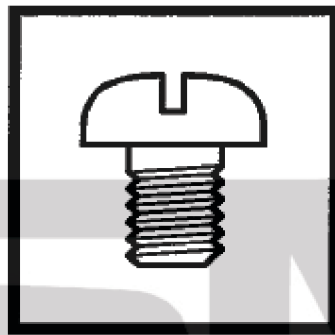

パーツブック
PARTS BOOK

ブラザー工業株式会社

〒467-8561 名古屋市瑞穂区苗代町 15 番 1 号 TEL (052) 824-2392

BROTHER INDUSTRIES, LTD

15-1, Naeshiro-cho, Mizuho-ku, Nagoya 467-8561, Japan. Phone : 81-52-824-2177

Printed in Japan

151-V41, V42
SA1930-001
2002.11. H (1)